

# GENERAL TURNING

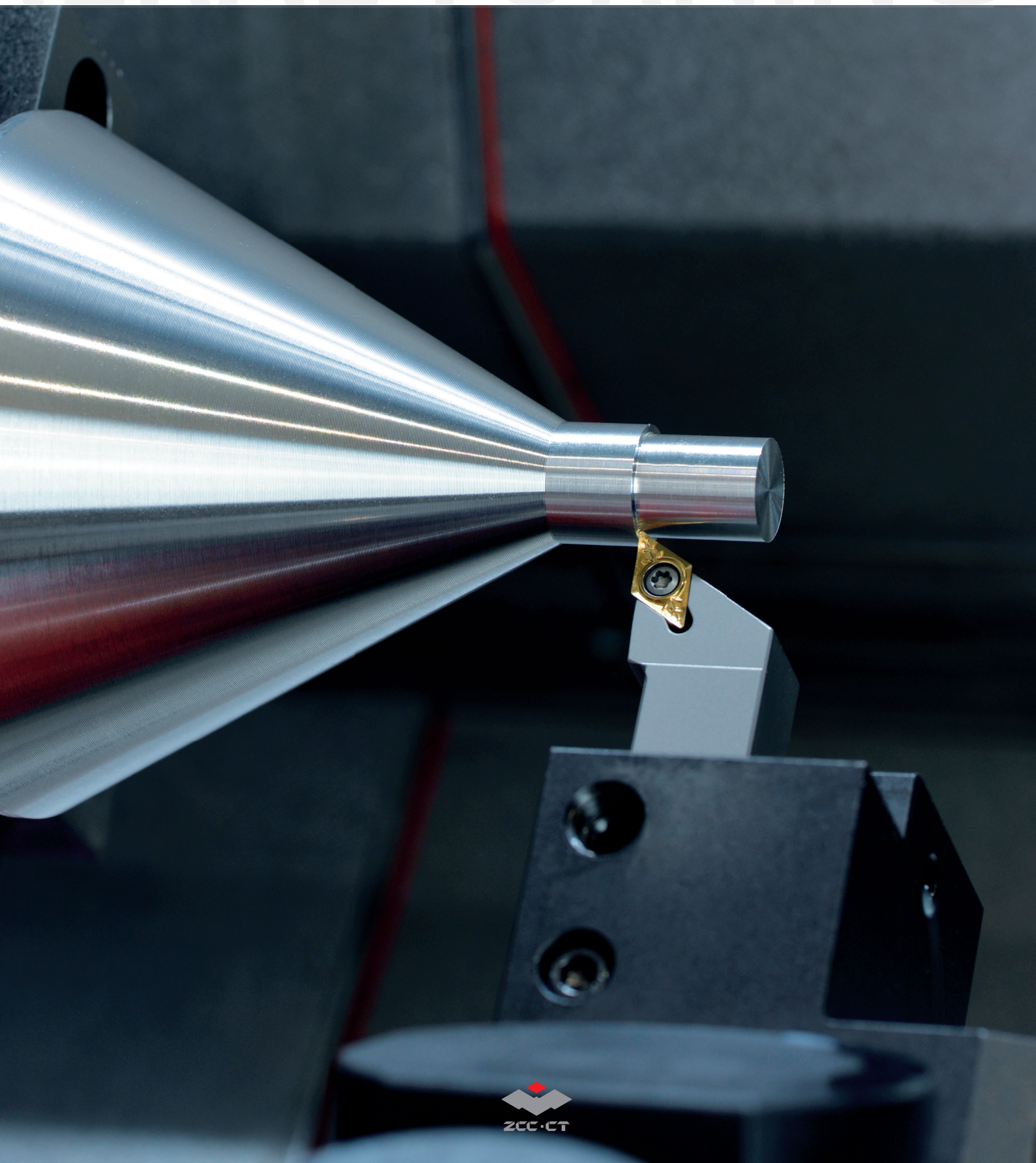



## General turning

Product overview	A2-A15
Chip breaker overview	A16-A26
Application fields of chip breakers	A27-A35
Grade overview	A36-A41
Application fields of grades	A42-A47
ISO code – general turning inserts	A48-A49
Conversion table metric/imperial	A50
Negative inserts	A51-A115
Positive inserts	A116-A157
ISO code – PCBN & PCD inserts	A158-A159
PCBN & PCD inserts	A160-A197
ISO code – ceramic inserts	A198-A199
Ceramic inserts	A200-A221
External tool holder overview	A222-A227
ISO code – external tool holders	A228-A229
External tool holders	A230-A303
ISO code – external tool holders – Swiss turning	A304-A305
External tool holders – Swiss turning	A306-A313
System code – external tool holders – rail applications	A314-A315
External tool holders – rail applications	A316-A319
Boring bar overview	A320-A321
ISO code – boring bars	A322-A323
Boring bars	A324-A365
Recommended cutting data	A366-A379
Trouble shooting	A502-A503
Technical information	A505-A509
Special tools	A513

## Carbide and cermet inserts

### Double sided, negative – Finishing



<b>CNEG-NF</b>	<b>CNMG-ADF</b>	<b>CNMG-DF</b>	<b>CNMG-EF</b>	<b>CNMG-SF</b>	<b>CNMG-XF</b>	Edge length
12	12	09 12	09 12	09 12	12	Page
A52	A51	A51	A51	A51	A52	

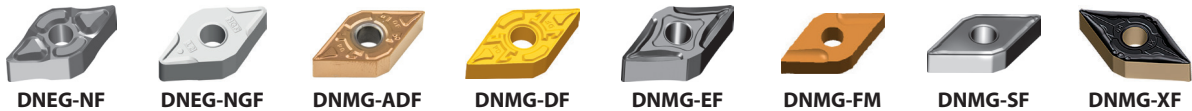

<b>DNEG-NF</b>	<b>DNEG-NGF</b>	<b>DNMG-ADF</b>	<b>DNMG-DF</b>	<b>DNMG-EF</b>	<b>DNMG-FM</b>	<b>DNMG-SF</b>	<b>DNMG-XF</b>	Edge length
15	15	15	11 15	11 15	15	11 15	11 15	Page
A66	A66	A62	A62	A66	A66	A62	A63	



<b>SNMG-ADF</b>	<b>SNMG-DF</b>	<b>SNMG-EF</b>	<b>SNMG-SF</b>	<b>SNMG-XF</b>	Edge length
12	12	09 12 15	09 12	12	Page
A71	A71	A72	A71	A73	



<b>TNMG-ADF</b>	<b>TNMG-DF</b>	<b>TNMG-EF</b>	<b>TNMG-FM</b>	<b>TNMG-SF</b>	Edge length
16	16 22	11 16 22	16	16	Page
A87	A87	A89	A90	A88	



<b>VNEG-NF</b>	<b>VNEG-NGF</b>	<b>VNMG-ADF</b>	<b>VNMG-DF</b>	<b>VNMG-EF</b>	<b>VNMG-SF</b>	<b>VNMG-XF</b>	Edge length
16	16	16	16	16	16	16	Page
A100	A101	A100	A100	A100	A101	A102	



<b>WNEG-NF</b>	<b>WNMG-ADF</b>	<b>WNMG-DF</b>	<b>WNMG-EF</b>	<b>WNMG-NF</b>	<b>WNMG-SF</b>	<b>WNMG-XF</b>	Edge length
08	08	06 08	06 08	06	06 08	06 08	Page
A106	A105	A105	A106	A106	A105	A107	

### Double sided, negative, Wiper – Finishing



<b>CNMG-WG</b>	<b>DNMX-WG</b>	<b>TNMX-WG</b>	<b>WNMG-WG</b>	Edge length
12	11 15	16	08	Page
A51	A62	A87	A106	

A

Turning

B

Milling

C

Drilling

D

Technical Information

E

Index

**Carbide and cermet inserts**

Double sided, negative – Medium machining

							
<b>CNMG</b>	<b>CNMG-DM</b>	<b>CNMG-EG</b>	<b>CNMG-EM</b>	<b>CNMG-NM</b>			
12 16 19	09 12 16 19	12	12 16	12	Edge length		
A61	A54	A54	A54	A56	Page		
							
<b>CNMG-PM</b>	<b>CNMG-TC</b>	<b>CNMG-TK</b>	<b>CNMG-XM</b>	<b>CNMG-ZM</b>			
09 12 16 19	12 16	12	12 16 19	12	Edge length		
A53	A56	A56	A53	A55	Page		
							
<b>DNMG-DM</b>	<b>DNMG-EG</b>	<b>DNMG-EM</b>	<b>DNMG-NM</b>				
11 15	15	11 15	15	Edge length			
A64	A67	A67	A67	Page			
							
<b>DNMG-PM</b>	<b>DNMG-TC</b>	<b>DNMG-TK</b>	<b>DNMG-XM</b>	<b>DNMG-ZM</b>			
11 15	15	15	11 15	15	Edge length		
A64	A67	A68	A63	A65	Page		
							
<b>SNMG</b>	<b>SNMG-DM</b>	<b>SNMG-EG</b>	<b>SNMG-EM</b>	<b>SNMG-NM</b>			
12 25	09 12 15 19	12	12 15	12	Edge length		
A83	A75	A75	A76	A77	Page		
							
<b>SNMG-PM</b>	<b>SNMG-TC</b>	<b>SNMG-TK</b>	<b>SNMG-XM</b>				
09 12 15 19	12 15	12	12 15 19	Edge length			
A74	A76	A76	A73	Page			
							
<b>TNMG</b>	<b>TNMG-DM</b>	<b>TNMG-EG</b>	<b>TNMG-EM</b>	<b>TNMG-PM</b>	<b>TNMG-TC</b>	<b>TNMG-XM</b>	<b>TNMG-ZM</b>
16 22 27 33	11 16 22	16	16 22	11 16 22	16 22	16 22	16
A98	A91	A93	A93	A91	A93	A90	A92
							Edge length
							Page

A

Turning

B

Milling

C

Drilling

D

Technical Information

E

Index

## Carbide and cermet inserts

Double sided, negative – Medium machining



**VNMG**      **VNMG-DM**      **VNMG-EM**      **VNMG-NM**

16	16	16	16
A103	A103	A103	A103

Edge length  
Page



**VNMG-PM**      **VNMG-SNR**      **VNMG-TC**      **VNMG-XM**      **VNMG-ZM**

16	16	16	16	16
A104	A104	A104	A102	A104

Edge length  
Page



**WNMG-DM**      **WNMG-EG**      **WNMG-EM**      **WNMG-NM**

06 08	08	06 08	08
A108	A108	A108	A110

Edge length  
Page

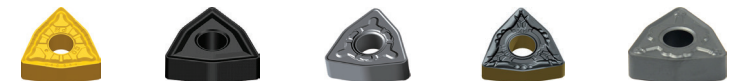

**WNMG-PM**      **WNMG-TC**      **WNMG-TK**      **WNMG-XM**      **WNMG-ZM**

06 08	08	08	06 08	08
A109	A110	A110	A107	A109

Edge length  
Page



**RNMG**

12
A112

Edge length  
Page

Double sided, negative – Medium machining to roughing



**CNMA**      **DNMA**      **SNMA**      **SNUN**      **TNMA**      **WNMA**

12 16 19	15	12 15 19	12 19	16 22	06 08
A61	A69	A84	A86	A99	A111

Edge length  
Page

Double sided, negative – Roughing









**CNMG-DR**      **CNMG-ER**      **CNMG-SNR**      **DNMG-DR**      **DNMG-ER**      **DNMG-SNR**

12 16 19 25	12 16 19	12 16 19	15	15	15
A57	A58	A57	A68	A69	A68

Edge length  
Page







## Carbide and cermet inserts

### Double sided, negative – Roughing







					
<b>SNMG-DR</b>	<b>SNMG-ER</b>	<b>SNMG-SNR</b>	<b>TNMG-DR</b>	<b>TNMG-ER</b>	<b>TNMG-SNR</b>
12 15 19 25	12 15 19	12	16 22 27	16 22	16
A77	A78	A78	A94	A95	A92
					Edge length
					Page





		
<b>WVMG-DR</b>	<b>WVMG-SNR</b>	
06 08	08	
A111	A109	
		Edge length
		Page

### Single sided, negative – Roughing







					
<b>CNMM</b>	<b>CNMM-DR</b>	<b>CNMM-ER</b>	<b>CNMM-HDR</b>	<b>CNMM-HPR</b>	<b>CNMM-LR</b>
12 19	12 16 19 25	25	12 16 19 25	19 25	12 16 19 25
A60	A58	A58	A60	A60	A59
					Edge length
					Page

			
<b>DNMM-DR</b>	<b>DNMM-ER</b>	<b>DNMM-HDR</b>	<b>DNMM-LR</b>
15	15	15	15
A70	A70	A70	A70
			Edge length
			Page

					
<b>SNMM</b>	<b>SNMM-DR</b>	<b>SNMM-ER</b>	<b>SNMM-HDR</b>	<b>SNMM-HPR</b>	<b>SNMM-LR</b>
19 25	15 19 25	25	12 15 19 25	19 25	12 15 19 25
A85	A79	A79	A81	A82	A80
					Edge length
					Page

			
<b>TNMM</b>	<b>TNMM-DR</b>	<b>TNMM-HDR</b>	<b>TNMM-LR</b>
16 22 27	16 22 27	22 27	16
A99	A95	A97	A95
			Edge length
			Page

### Special form – Finishing

					
<b>CNMG-RF</b>	<b>CNMM-RF</b>	<b>CNMM-RH</b>	<b>KNUX</b>	<b>LNUX-RF</b>	<b>LNUX-RH</b>
19	19	19	16	19 30	19 30
A114	A114	A114	A113	A115	A115
					Edge length
					Page

A

Turning

B

Milling

C

Drilling

D

Technical Information

E

Index

## Carbide and cermet inserts

### Positive – Fine-finishing

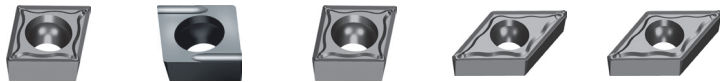

<b>CCGT-SF</b>	<b>CCGT-USF</b>	<b>CPGT-SF</b>	<b>DCGT-SF</b>	<b>DPGT-SF</b>
06 09 A116	06 09 A116	06 09 A124	07 11 A125	07 11 A131

Edge length  
Page



<b>TBGH</b>	<b>TCGT-SF</b>	<b>TPGH</b>	<b>TPGT-SF</b>
06 A139	06 09 11 A140	09 11 A146	09 11 A147

Edge length  
Page



<b>VBGT-SF</b>	<b>VCGT-SF</b>
11 A150	11 16 A153

Edge length  
Page

### Positive – Finishing



<b>CCMT-AHF</b>	<b>CCMT-EF</b>	<b>CCMT-HF</b>	<b>CCMT-XF</b>	<b>CPMT-HF</b>
06 09 12 A117	06 09 12 A118	06 09 12 A117	06 09 A118	06 A124

Edge length  
Page



<b>DCMT-AHF</b>	<b>DCMT-EF</b>	<b>DCMT-HF</b>	<b>DCMT-XF</b>	<b>SCMT-AHF</b>	<b>SCMT-EF</b>	<b>SCMT-HF</b>	<b>SCMT-XF</b>
07 11 A125	07 11 A126	07 11 A126	07 11 A126	09 A134	09 A134	09 A135	09 A134

Edge length  
Page



<b>TCMT-AHF</b>	<b>TCMT-EF</b>	<b>TCMT-HF</b>	<b>TCMT-XF</b>
11 16 A141	09 11 16 A142	09 11 16 A141	09 11 16 A141

Edge length  
Page







<b>VBET-NF</b>	<b>VBET-NGF</b>	<b>VBMT-AHF</b>	<b>VBMT-EF</b>	<b>VBMT-HF</b>	<b>VBMT-XF</b>
16 A149	16 A151	16 A148	11 16 A148	11 A149	11 16 A148

Edge length  
Page

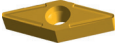

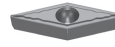

## Carbide and cermet inserts

### Positive – Finishing



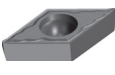

				
<b>VCGT</b>	<b>VCGT-HF</b>	<b>VCGT-NF</b>	<b>VCMT-EF</b>	<b>VCMT-XF</b>
13	11	16	16	11 16
A153	A153	A153	A156	A156
				Edge length
				Page





### Positive – Medium machining

					
<b>CCMT-EM</b>	<b>CCMT-HM</b>	<b>CCMT-XM</b>	<b>CCMW</b>	<b>CPGW</b>	<b>CPMT-HM</b>
06 09 12	06 09 12	09 12	09 12	06	09
A119	A120	A119	A121	A124	A124
					Edge length
					Page









			
<b>DCMT-EM</b>	<b>DCMT-HM</b>	<b>DCMT-XM</b>	<b>DCMW</b>
07 11	07 11	11	11
A127	A128	A127	A129
			Edge length
			Page

			
<b>SCMT-EM</b>	<b>SCMT-HM</b>	<b>SPMW</b>	<b>SCMT-XM</b>
09 12	09 12	09 12	09 12
A134	A135	A138	A135
			Edge length
			Page

				
<b>TCMT</b>	<b>TCMT-EM</b>	<b>TCMT-HM</b>	<b>TCMW</b>	<b>TCMT-XM</b>
22	09 11 16	09 11 16	16	16
A144	A142	A143	A143	A142
				Edge length
				Page

				
<b>VBMT-EM</b>	<b>VBMT-HM</b>	<b>VBMT-XM</b>	<b>VCMT-EM</b>	<b>VCMT-XM</b>
11 16	16	16	16	16
A151	A151	A151	A156	A156
				Edge length
				Page

### Positive – Roughing

							
<b>CCMT-HR</b>	<b>CCMT-TC</b>	<b>DCMT-HR</b>	<b>RCMT · RCGT</b>	<b>RCMX</b>	<b>RCMX-PV</b>	<b>SCMT-HR</b>	<b>TCMT-HR</b>
06 09 12	06 09 12	11	08 10 12 16 20 25	08 10 12 16 20 25 32	32	09 12	09 11 16 22
A121	A121	A129	A132	A133	A133	A136	A143
							Edge length
							Page

A

Turning

B

Milling

C

Drilling

D

Technical Information

E

Index



## Carbide and cermet inserts

### Positive – Roughing



**VBMT-HR**      **VBMT-SNR**

16	16
A152	A152

Edge length  
Page

### Positive – Aluminium machining

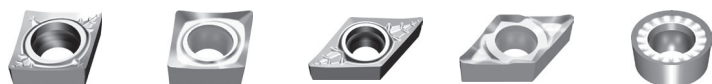

**CCGX-LC**      **CCGX-LH**      **DCGX-LC**      **DCGX-LH**      **RCGX-LH**

06 09 12	06 09 12	07 11	07 11	08 12
A122	A122	A129	A130	A132

Edge length  
Page



**SCGX-LC**      **SCGX-LH**      **TCGX-LC**      **TCGX-LH**      **VCGX-LC**      **VCGX-LH**

09 12	09 12	09 11 16	09 11 16	11 16 22	11 16 22
A136	A137	A145	A145	A154	A155

Edge length  
Page

## PCBN & PCD

### Negative

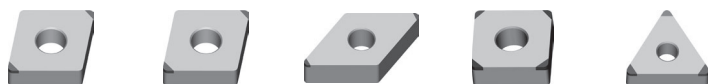

**CNGA-2**      **CNGA-2W**      **DNGA-2**      **SNGA-4**      **TNGA-3**

12	12	15	12	16
A160	A160	A161	A162	A163

Edge length  
Page

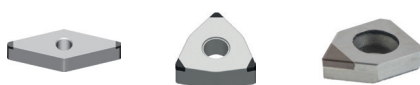

**VNGA-2**      **WNGA-3**      **ZNEX**

16	08	04
A164	A165	A166

Edge length  
Page





**CNGN**      **CNGN-M**      **RNGN**      **SNGN**      **SNGN-M**      **WNGN**      **WNGN-M**

09 12	12	09 12	12	12	08	08
A173	A173	A174	A175	A175	A176	A176



Edge length  
Page

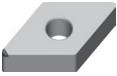

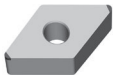

## PCBN & PCD

### Negative

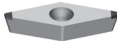
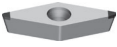



			
<b>CNGA</b>	<b>DNGA</b>	<b>VNGA</b>	
12	15	16	Edge length
A177	A178	A179	Page



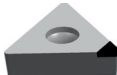

### Positive

					
<b>CCGW-2</b>	<b>DCGW-2</b>	<b>TCGW-3</b>	<b>VBGW-2</b>	<b>VCGW-2</b>	
06 09 12	07 11	11 16	16	11 16	Edge length
A167	A169	A170	A171	A172	Page

					
<b>CCGT</b>	<b>CCGT-1MED</b>	<b>CCGT-L</b>	<b>CCGW</b>	<b>CCGW-L</b>	
06 09 12	06 09	09 12	06 09 12	06 09 12	Edge length
A180	A180	A181	A182	A183	Page



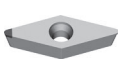

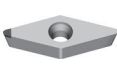

			
<b>DCGT</b>	<b>DCGT-1MED</b>	<b>DCGW</b>	
07 11	07 11	07 11	Edge length
A184	A185	A186	Page

					
<b>TCGT</b>	<b>TCGT-1MED</b>	<b>TCGT-L</b>	<b>TCGW</b>	<b>TCGW-L</b>	
11 16	11 16	11 16	11 16	11 16	Edge length
A187	A187	A188	A189	A190	Page

						
<b>VBGT</b>	<b>VBGT-1MED</b>	<b>VBGW</b>	<b>VCGT</b>	<b>VCGT-1MED</b>	<b>VCGW</b>	
11 16	16	11 16	11 16	11 16	11 16 22	Edge length
A191	A191	A192	A193	A194	A195	Page

## Ceramic inserts

### Negative

						
<b>CNGA</b>	<b>CNGN</b>	<b>CNGX</b>	<b>DNGA</b>	<b>DNGN</b>	<b>DNGX</b>	
12 16	12 16	12	15	15	15	Edge length
A200	A201	A203	A204	A205	A206	Page

**A**

Turning

## Ceramic inserts

### Negative



**RNGA**

12

A207



**RNGN**

06 09 12 15 19 25

A208



**SNGA**

12

A210



**SNGN**

12 15 19

A211



**SNGX**

12

A213



**TNGA**

16 22

A214



**TNGN**

16 22

A215

Edge length

Page

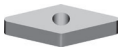

**VNGA**

16

A216



**WNGA**

08

A217

Edge length

Page

**B**

Milling

### Positive



**RCGX**

06 09 12 19

A218



**RPGN**

12

A219



**RPGX**

09

A220



**TPGN**

11 16

A221

Edge length

Page

**C**

Drilling

**D**





Technical Information

**E**



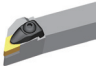



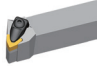

Index



## External tool holders

## Holder with double clamping









							
<b>DCLNR/L</b>	<b>DDJNR/L</b>	<b>DSBNR/L</b>	<b>DTGNR/L</b>	<b>DVJNR/L</b>	<b>DVVNN</b>	<b>DWLNR/L</b>	
95°	93°	75°	90°	93°	72.5°	95°	Angle
A230	A231	A232	A233	A235	A234	A236	Page









## Holder with knee lever clamping

								
<b>PCBNR/L</b>	<b>PCLNR/L</b>	<b>PDJNR/L</b>	<b>PDNNR/L</b>	<b>PSBNR/L</b>	<b>PSDNN</b>	<b>PSKNR/L</b>	<b>PSSNR/L</b>	
75°	95°	93°	63°	75°	45°	75°	45°	Angle
A237	A238	A240	A241	A242	A244	A245	A246	Page

				
<b>PTFNR/L</b>	<b>PTGNR/L</b>	<b>PTTNR/L</b>	<b>PWLNR/L</b>	
91°	90°	60°	95°	Angle
A247	A249	A248	A251	Page

## Holder with multi clamping

								
<b>MCBNR/L</b>	<b>MCLNR/L</b>	<b>MDJNR/L</b>	<b>MDPNN</b>	<b>MRDNN</b>	<b>MRGNR/L</b>	<b>MSBNR/L</b>	<b>MSDNN</b>	
75°	95°	93°	62.5°	45°	90°	75°	45°	Angle
A252	A253	A254	A255	A267	A268	A256	A259	Page

								
<b>MSKNR/L</b>	<b>MSRNR/L</b>	<b>MTFNR/L</b>	<b>MTGNR/L</b>	<b>MTJNR/L</b>	<b>MTJNR/L-Z</b>	<b>MVJNR/L</b>	<b>MVVNN</b>	
75°	75°	90°	90°	93°	93°	93°	72.5°	Angle
A258	A257	A263	A260	A261	A262	A265	A264	Page

	
<b>MWLNR/L</b>	
95°	Angle
A266	Page

A

Turning

B

Milling

C

Drilling

D

Technical  
Information

E

Index

## External tool holders

### Holder with screw clamping



SCACR/L	SCLCR/L	SDACR/L	SDJCR/L	SDNCN	SRDCN	SRGCR/L	SSBKR/L	Angle
90°	95°	90°	93°	63°	45°	90°	75°	Page
A269	A270	A271	A272	A273	A288	A289	A279	



SSDCN	SSKCR/L	SSSCR/L	STACR/L	STFCR/L	STGCR/L	STTCR/L	SVABR/L	Angle
45°	75°	45°	90°	90°	90°	60°	90°	Page
A280	A281	A282	A283	A284	A285	A286	A275	

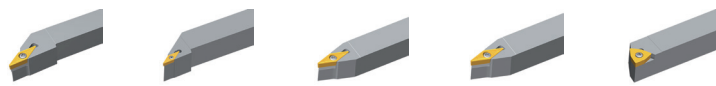

SVJBR/L	SVJCR/L	SVVBN	SVVCN	SWACR/L	Angle
93°	93°	72.5°	72.5°	90°	Page
A274	A278	A276	A277	A287	

### Holder with top clamping



CKJNR/L	CKNNR/L	Angle
93°	63°	Page
A290	A291	

### Tool holder for ceramic inserts and solid CBN inserts









CCLNR/L	CDJNR/L	CRDNN	CSDNN	CSKNR/L	CSRNR/L	CTJNR/L	CTUNR/L	Angle
95°	93°	45°	45°	75°	75°	93°	93°	Page
A292	A294	A298	A299	A296	A297	A293	A295	

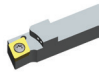

JCLNR/L	JDJNR/L	JSDNN	Angle
95°	93°	45°	Page
A300	A301	A302	

## External tool holders

### Swiss turning

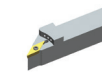



								
<b>SCACR/L-SC</b>	<b>SCLCR/L-SC</b>	<b>SDACR/L-SC</b>	<b>SDHCR/L-SC</b>	<b>SDJCR/L-SC</b>	<b>SDNCN-SC</b>	<b>SVACR/L-SC</b>	<b>SVJCR/L-SC</b>	
90°	95°	90°	107.5°	93°	63°	90°	93°	Angle
A306	A307	A308	A309	A310	A311	A312	A313	Page







### Rail applications

			
<b>RW-PCLNR/L</b>	<b>RW-PLANR/L</b>	<b>RW-PLFNR/L</b>	
90°	90°	90°	Angle
A318	A316	A317	Page

### Boring bars







#### Steel boring bars with knee lever clamping –

					
<b>A***-PCLNR/L</b>	<b>A***-PDSNR/L</b>	<b>A***-PDUNR/L</b>	<b>A***-PSKNR/L</b>	<b>A***-PTFNR/L</b>	
95°	45°	93°	75°	90°	Angle
A324	A326	A327	A329	A330	Page

						
<b>S***-PCLNR/L</b>	<b>S***-PDSNR/L</b>	<b>S***-PDUNR/L</b>	<b>S***-PSKNR/L</b>	<b>S***-PTFNR/L</b>	<b>S***-PWLNR/L</b>	
95°	45°	93°	75°	90°	95°	Angle
A324	A326	A327	A329	A330	A332	Page

#### Steel boring bars with screw clamping –

				
<b>A***-SCLCR/L</b>	<b>A***-SDQCR/L</b>	<b>A***-SDUCR/L</b>	<b>A***-SDZCR/L</b>	
95°	107.5°	93°	95°	Angle
A334	A336	A337	A338	Page

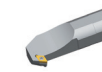
								
<b>S***-SCFCR/L</b>	<b>S***-SCLCR/L</b>	<b>S***-SCLPR/L</b>	<b>S***-SDQCR/L</b>	<b>S***-SDQPR/L</b>	<b>S***-SDUCR/L</b>	<b>S***-SDUPR/L</b>	<b>S***-SDZCR/L</b>	
90°	95°	95°	107.5°	107.5°	93°	93°	95°	Angle
A352	A334	A348	A336	A349	A337	A350	A338	Page

A

Turning

B

Milling

C

Drilling

D

Technical Information

E





Index

**A**

Turning







## Boring bars

Steel boring bars with screw clamping –

				
<b>A***-SSKCR/L</b>	<b>A***-STFCR/L</b>	<b>A***-SVQBR/L</b>	<b>A***-SVUBR/L</b>	
75°	90°	107.5°	93°	Angle
A339	A341	A345	A346	Page

**B**

Milling







							
<b>S***-SSKCR/L</b>	<b>S***-STFCR/L</b>	<b>S***-STUPR/L</b>	<b>S***-SVQBR/L</b>	<b>S***-SVQCR/L</b>	<b>S***-SVUBR/L</b>	<b>S***-SVUCR/L</b>	
75°	90°	93°	107.5°	107.5°	93°	93°	Angle
A339	A341	A351	A345	A343	A346	A344	Page

**C**

Drilling

Solid carbide boring bars with screw clamping –

							
<b>C***-SCLPR/L</b>	<b>C***-SDQPR/L</b>	<b>C***-SDUPR/L</b>	<b>C***-STUPR/L</b>	<b>C***-SVQCR/L</b>	<b>C***-SVUCR/L</b>	<b>C***-SZLNR/L</b>	
A354	A356	A358	A360	A363	A364	A365	Page

							
<b>E***-SCLCR/L</b>	<b>E***-SCLPR/L</b>	<b>E***-SDQCR/L</b>	<b>E***-SDUCR/L</b>	<b>E***-STFCR/L</b>	<b>E***-STFPR/L</b>	<b>E***-SVUCR/L</b>	
95°	95°	107.5°	93°	90°	90°	93°	Angle
A355	A354	A357	A359	A361	A362	A364	Page

**D**

Technical Information

**E**

Index

**Notes**

Dotted lines for notes

**A**

Turning

**B**

Milling

**C**

Drilling

**D**

Technical  
Information

**E**

Index



**A**

Turning

## Negative inserts

Finishing



Double-sided chip breaker for finishing operations in the P application field. Superb chip control with low cutting forces.

**B**

Milling



Double-sided chip breaker for applications from finishing to medium machining.

**C**

Drilling

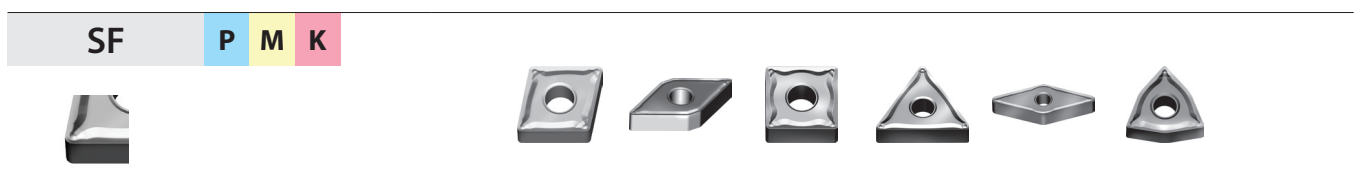

Double sided chip breaker in combination with cermet grades. Geometry with high sharpness for improved chip control and great surface quality. Ideal for machining with small cutting depths and feed rates.

**D**

Technical Information



Double sided chip breaker with good chip control. Suitable for finishing and medium machining of steel and cast iron.



Ground, double sided chip breaker with good chip control. Wide range of application due to excellent balance of sharpness and cutting edge stability.

**E**

Index

Negative inserts

Finishing

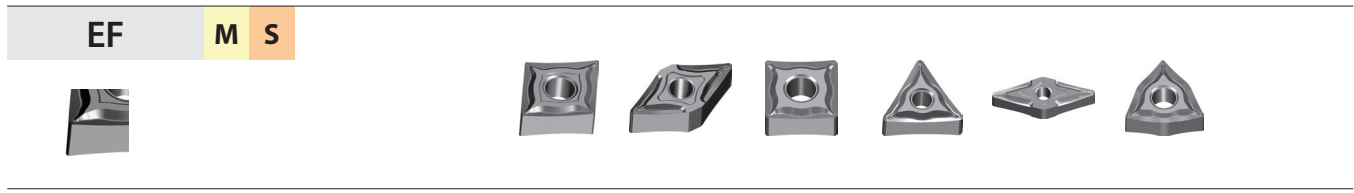

Double sided chip breaker with sharp cutting edge and large rake angle for finishing of stainless steel.

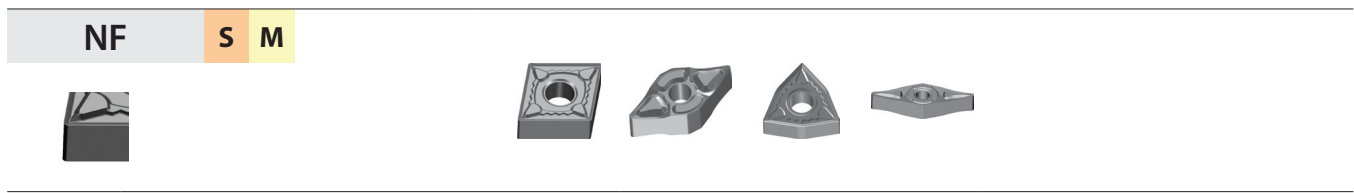

Double sided chip breaker with ground cutting edge and large rake angle for finishing. E-tolerance for high repeatability.

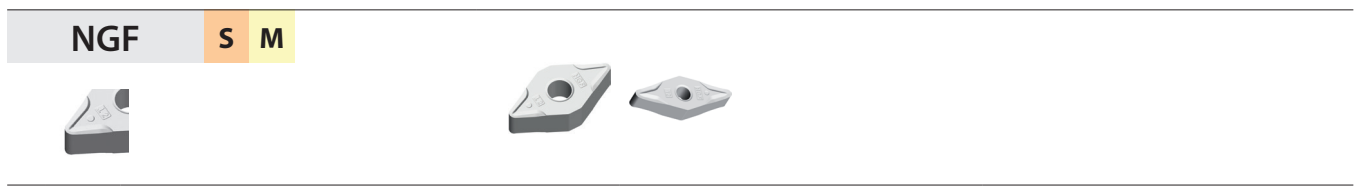

Double sided chip breaker with ground cutting edge and large rake angle for finishing. E-tolerance for high repeatability.

Wiper



Double sided chip breaker with wiper geometry. Allows to double the feed rate and improves the surface quality.

Medium machining



Double-sided chip breaker for medium machining operations in the P application field. Superb chip control at high and low feed rates.

A

Turning

B

Milling

C

Drilling

D

Technical Information

E

Index

**A**

Turning

## Negative inserts

Medium machining

DM P K



Double sided chip breaker for medium machining. Wide range of application due to excellent balance of sharpness and cutting edge stability.

**B**

Milling

ZM P



Double sided chip breaker for medium machining. Wide range of application due to stable cutting edge and large rake angle. Very suitable for machining of steel.

**C**

Drilling

PM P K



Double sided chip breaker for medium machining. Wide range of application in steel and cast iron.

**D**

Technical Information

TC K P



Double sided chip breaker with surrounding cutting edge. Process reliable machining due to highest cutting edge stability.

TK K



Double-sided chip breaker for medium machining operations in the K application field. Optimum combination of impact resistance and cutting edge sharpness.

**E**

Index

Negative inserts

Medium machining

NM S M

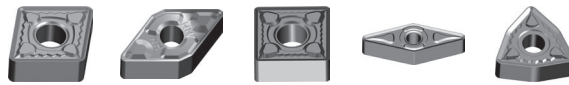

Double sided chip breaker with ground cutting edge and large rake angle for medium machining of heat-resistant materials.

EM M S



Double sided chip breaker with sharp cutting edge and large rake angle. Process reliable medium machining of stainless steel.

EG M S

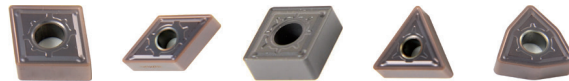

Double sided chip breaker with grinded cutting edge and large rake angle. Wide range of application for medium machining of stainless steel.

Basic P K



Double sided chip breaker with surrounding cutting edge for universal machining of steel and cast iron.

Roughing

DR double sided P K



Double sided chip breaker with positive rake angle and stable cutting edge for light to medium roughing of steel and cast iron.

A

Turning

B

Milling

C

Drilling

D

Technical Information

E

Index

A

Turning

## Negative inserts

### Roughing

**DR** single sided **P** **K**



Single sided chipbreaker with positive rake angle and stable cutting edge for light to medium roughing of steel and cast iron.

B

Milling

**RH** **P**



Double-sided chip breaker for applications from medium machining to roughing.

C

Drilling

**LR** **P** **M**



Single sided chip breaker with curved cutting edge and unique bumpy geometry. Low cutting pressure for process reliable machining. Light roughing of steel and stainless steel.

D

Technical Information

**ER** double sided **M** **S**



Double sided chip breaker with large rake angle for low cutting forces. Suitable for roughing of stainless steel.

**ER** single sided **M** **S**



Single sided chip breaker with large rake angle for low cutting forces. Suitable for roughing of stainless steel.

E

Index

Negative inserts

Roughing



Single sided chip breaker with high cutting edge stability and deformation resistance. Excellent for roughing with high cutting depths in steel and stainless steel.

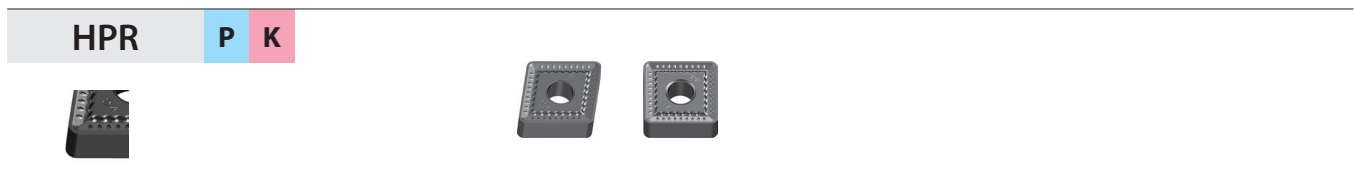

Single sided chip breaker with high cutting edge stability and large chip space. Excellent for heavy roughing in steel and cast iron.

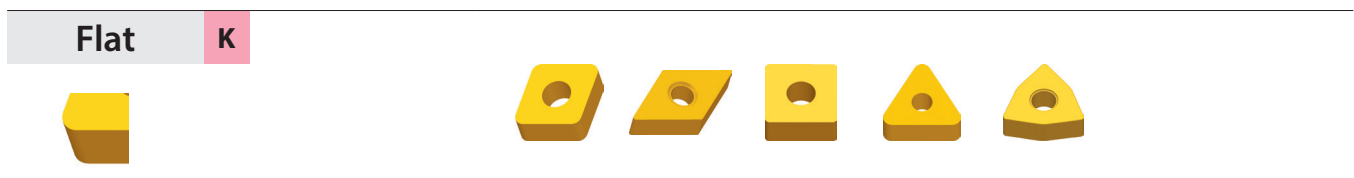

Double sided insert without chip breaker. Stable cutting edge design, due to missing microgeometry. Excellent for roughing in cast iron.

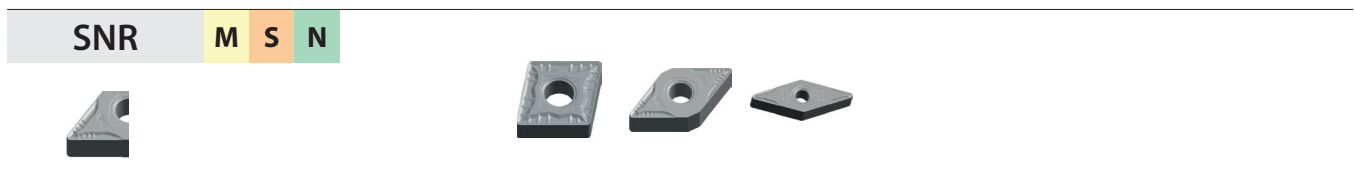

Double sided chip breaker for roughing. Wide range of application due to excellent balance of sharpness and cutting edge stability.

PCBN & PCD inserts

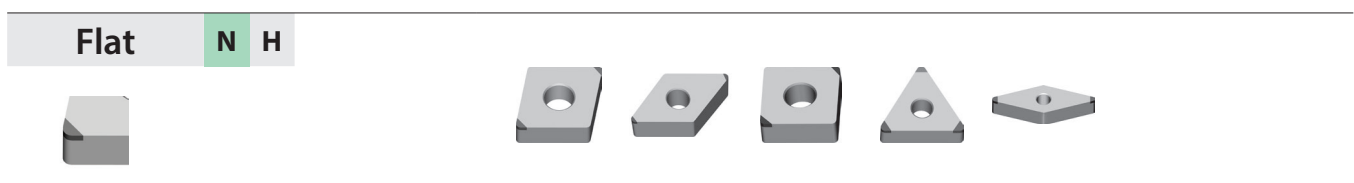

With brazed CBN or PCD cutting edge. For machining of hardened steel (CBN) or non-ferrous metals (PCD).

A

Turning

B

Milling

C

Drilling

D

Technical Information

E

Index

**A**

Turning

## Negative inserts

PCBN & PCD inserts

Flat H K



Solid CBN insert for machining of steel and cast iron.

**B**

Milling

## Ceramic inserts

Flat K H



Ceramic inserts for machining of low hardened steel and cast iron.

**C**

Drilling

## Positive inserts

Fine-finishing

USF P M



Single sided chip breaker for fine finishing. Sharp cutting edge with large hollow flute, excellently suitable for machining small work pieces. G-tolerance for high repeatability.

**D**

Technical Information

R/L P M



Single sided chip breaker for fine finishing. Excellent for high surface quality. G-tolerance for high repeatability.

**E**

Index

SF P M

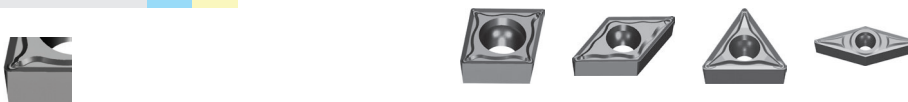

Single sided chip breaker in combination with cermet grades. Geometry with high sharpness for improved chip control and great surface quality. Ideal for machining with small cutting depths and feed rates.

**Positive inserts**

Finishing



Single-sided chip breaker for finishing operations in the P application field. Superb chip control with low cutting forces.



Single sided chip breaker with good chip control. Suitable for finishing to medium machining of steel and cast iron.



Ground, single sided chip breaker with good chip control. Wide range of application due to excellent balance of sharpness and cutting edge stability.

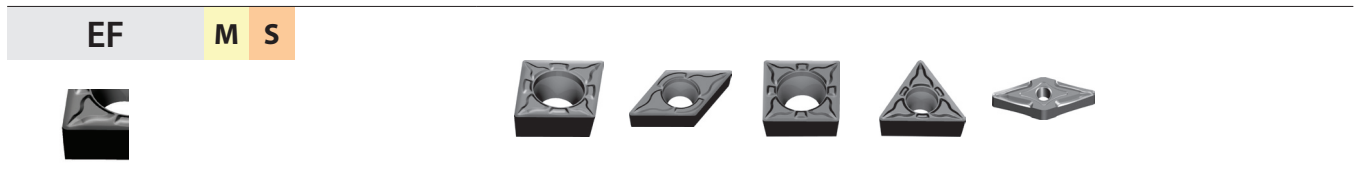

Single sided chip breaker with sharp cutting edge and large rake angle for finishing of stainless steel.

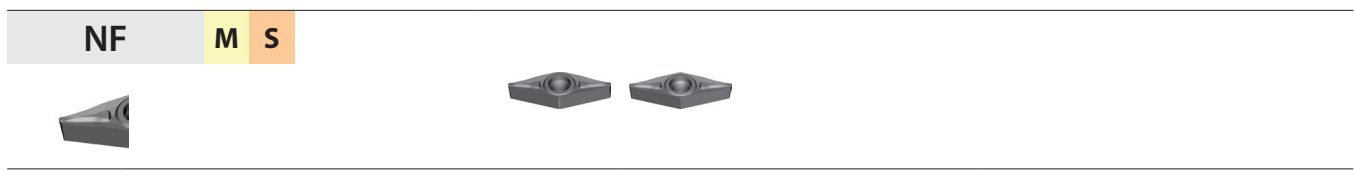

Single sided chip breaker with ground cutting edge and large rake angle for finishing. E-tolerance for high repeatability.

**A**

Turning

**B**

Milling

**C**

Drilling

**D**

Technical Information

**E**

Index



**A**

Turning

## Positive inserts

Finishing

NGF M S



Single sided chip breaker with ground cutting edge and large rake angle for finishing. E-tolerance for high repeatability.

**B**

Milling

## Medium machining

XM P

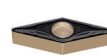

Single-sided chip breaker for medium machining operations in the P application field. Superb chip control at high and low feed rates.

**C**

Drilling

TC K P



Single sided chip breaker with encircling cutting edge. Process reliable machining due to highest cutting edge stability.

**D**

Technical Information

HM P K



Single sided chip breaker for medium machining. Wide range of application due to excellent balance of sharpness and cutting edge stability.

**E**

Index

EM M S

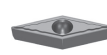
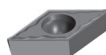
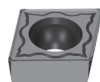

Single sided chip breaker with sharp cutting edge and large rake angle. Process reliable medium machining of stainless steel.

**Positive inserts**

Medium machining

**Basic** P K



Single sided chip breaker with encircling cutting edge for universal machining of steel and cast iron.

Roughing

**Flat** K



Single sided insert without chip breaker. Stable cutting edge design due to missing microgeometry. Excellent for roughing in cast iron.

**HR** P K



Single sided chip breaker with positive rake angle and stable cutting edge for light to medium roughing of steel and cast iron.

**SNR** S M



Single sided chip breaker for roughing. Wide range of application due to excellent balance of sharpness and cutting edge stability.

**Basic** P K



Single sided chip breaker with encircling cutting edge for universal machining of steel and cast iron.

**A**

Turning

**B**

Milling

**C**

Drilling

**D**

Technical Information

**E**

Index

**A**

Turning

## Positive inserts

Aluminium machining



Single sided chip breaker with excellent cutting edge design. Sharp cutting edge with positive rake angle. G-tolerance for high repeatability.

**B**

Milling

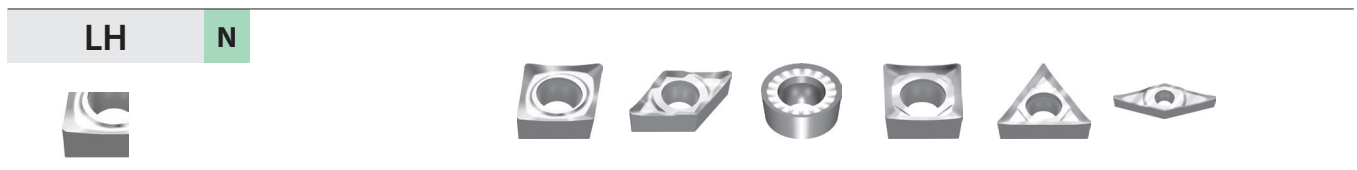

Single sided chipbreaker for machining of cast aluminium alloys. Sharp cutting edge with positive rake angle. G-tolerance for high repeatability.

## PCBN & PCD inserts

**C**

Drilling

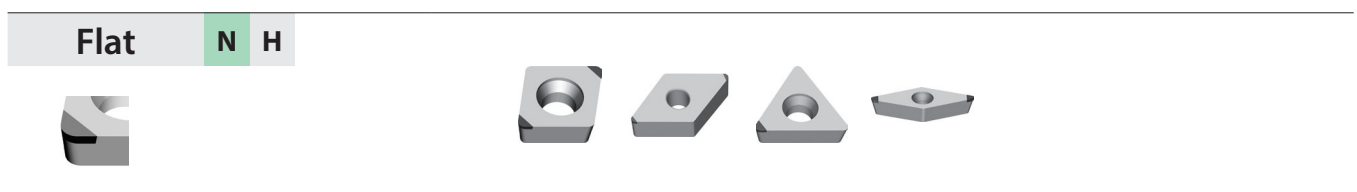

With brazed CBN or PCD cutting edge. For machining of hardened steel (CBN) or non-ferrous metals (PCD).

**D**

Technical Information

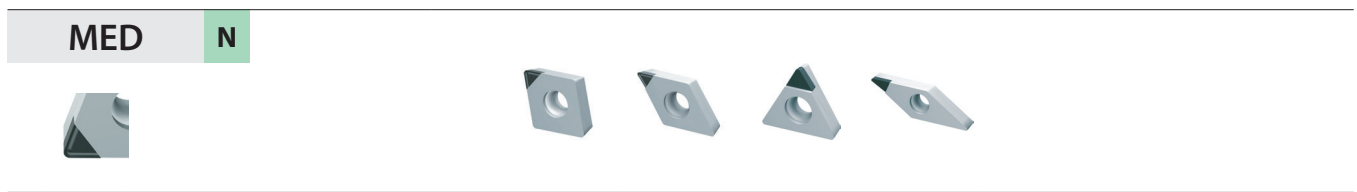

Laser-cut chip breaker for finishing and medium machining operations.

**E**

Index

## General turning

### Application fields of chip breakers

**Example**

Insert: CNMG120408-DF  
 Holder: PCLNL2525M12  
 Material: C45 steel  
 $V_C$ : 200 m/min

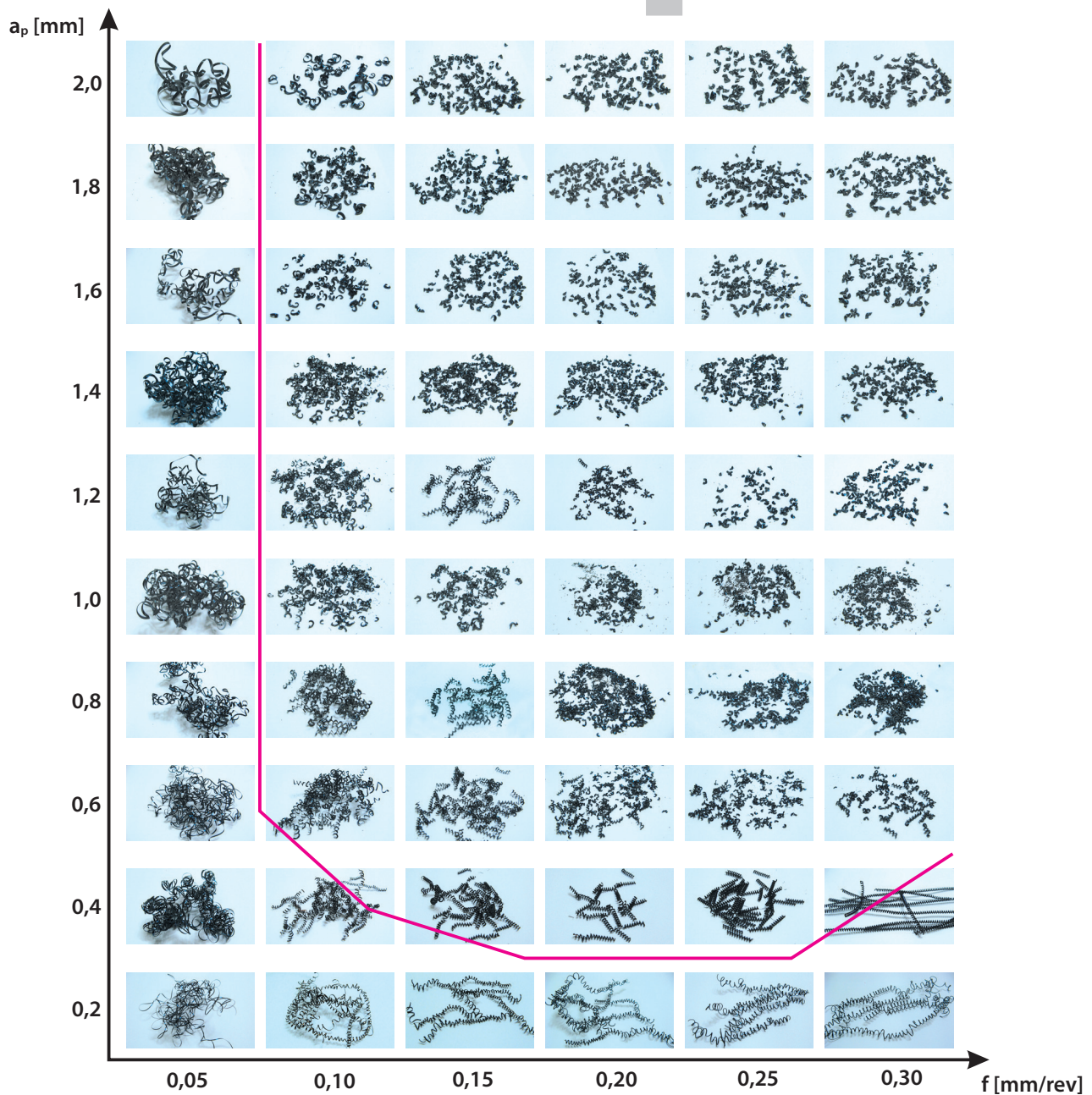
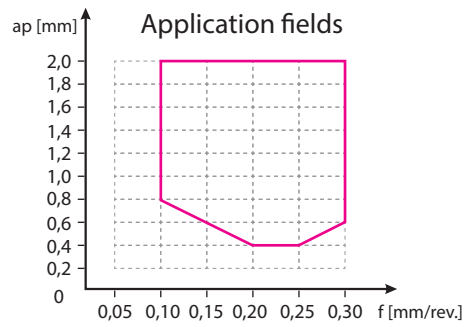

**A**

Turning

**B**

Milling

**C**

Drilling











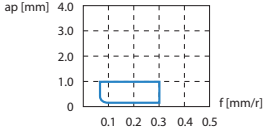
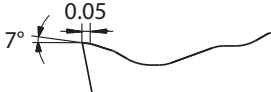

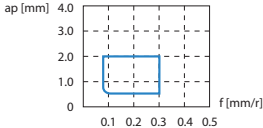
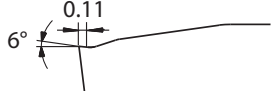

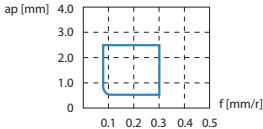
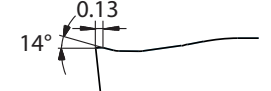

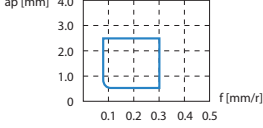
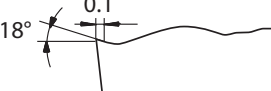
**D**

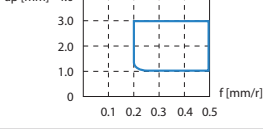
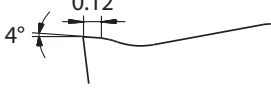
Technical Information

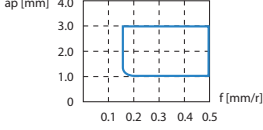
**E**

Index

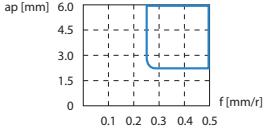
**P** Positive inserts

Chip breaker	Application		Application fields	Cutting edge design
SF	Fine-finishing			
HF	Finishing	 		
AHF	Finishing	 		
XF	Finishing	 		
HM	Medium machining	 		
XM	Medium machining	 		
HR	Roughing	  		

**A**

Turning

**B**

Milling

**C**

Drilling

**D**

Technical Information

**E**

Index

**P** Negative inserts

Chip breaker	Application	Application fields	Cutting edge design
SF	Fine-finishing		
DF	Finishing		
XF	Finishing		
ADF	Finishing		
DM	Medium machining		
PM	Medium machining		
ZM	Medium machining		
XM	Medium machining		
WG	Medium machining		
Basic	Medium machining		
DR	Roughing		

**A**

Turning

**B**

Milling

**C**

Drilling

**D**

Technical Information

**E**

Index



## P Negative inserts

Chip breaker	Application		Application fields	Cutting edge design
DR (single sided)	Roughing			
LR (single sided)	Roughing			
HDR (single sided)	Roughing			
HPR (single sided)	Roughing			





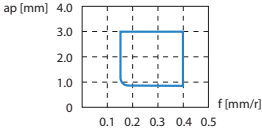
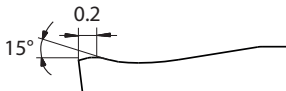

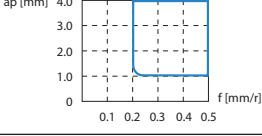
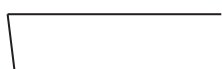
## P Negative inserts (rail technology)

Chip breaker	Application		Application fields	Cutting edge design
RF	Finishing			
RH	Roughing			

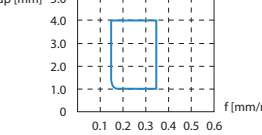
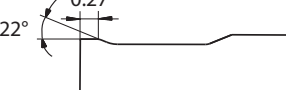
**K Positive inserts**

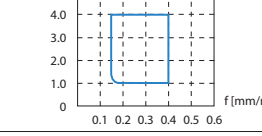
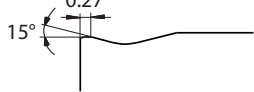
Chip breaker	Application		Application fields	Cutting edge design
TC	Medium machining			
Flat	Roughing			

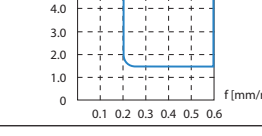
**K Negative inserts**

Chip breaker	Application		Application fields	Cutting edge design
TK	Medium machining			
TC	Medium machining			
Flat	Roughing			

**A**

Turning

**B**

Milling

**C**

Drilling

**D**







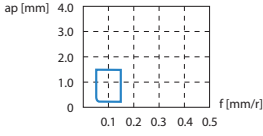

Technical Information

**E**



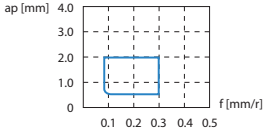
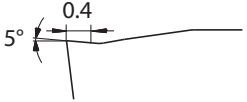



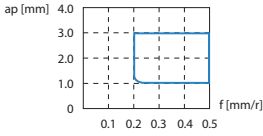
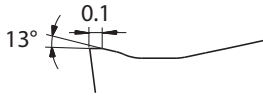



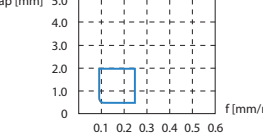
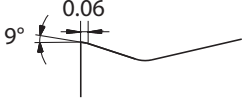

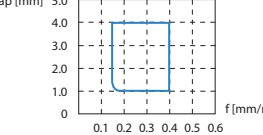
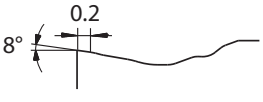
Index

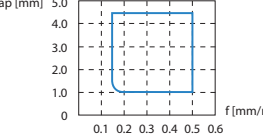
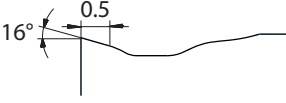

## M Positive inserts

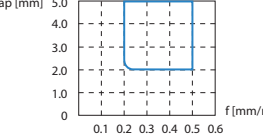
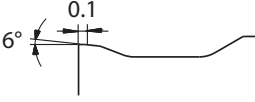
Chip breaker	Application		Application fields	Cutting edge design
USF	Fine-finishing			
EF	Finishing	 		
EM	Medium machining	  		

## M Negative inserts

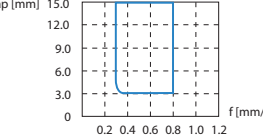
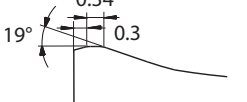
Chip breaker	Application		Application fields	Cutting edge design
EF	Finishing			
EM	Medium machining	 		
EG	Medium machining	 		
ER	Roughing	  		
ER (single sided)	Roughing	  		

A

Turning

B

Milling

C

Drilling







D

Technical Information

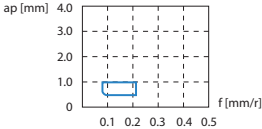

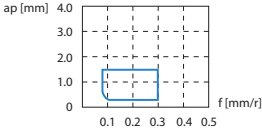

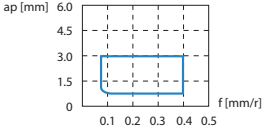

E

Index

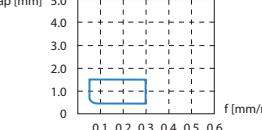
**S** Positive inserts

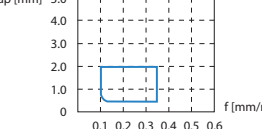
Chip breaker	Application		Application fields	Cutting edge design
NF	Finishing			
NGF	Finishing			
SNR	Roughing			

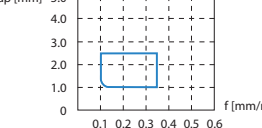
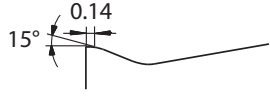
**S** Negative inserts

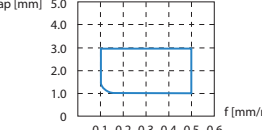
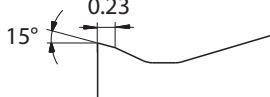
Chip breaker	Application		Application fields	Cutting edge design
NF	Finishing			
NGF	Medium machining			
NM	Medium machining			
SNR	Roughing			

A

Turning

B

Milling

C

Drilling



D

Technical Information

E

Index

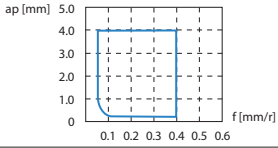
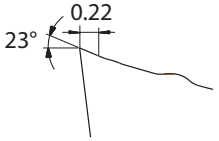
**N** Positive inserts

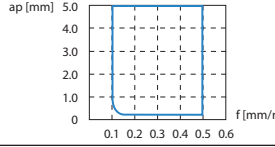
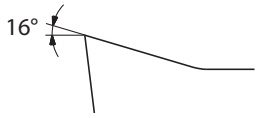
Chip breaker	Application		Application fields	Cutting edge design
LC	Finishing			
LH	Finishing			

**A**

Turning

**B**

Milling

**C**

Drilling

**D**

Technical Information

**E**

Index

**Notes**

Dotted lines for notes.

**A**

Turning

**B**

Milling

**C**

Drilling

**D**

Technical  
Information

**E**

Index

## Coated cemented carbide CVD

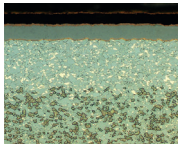
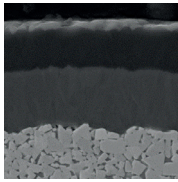
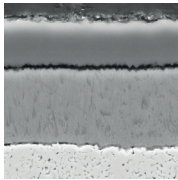
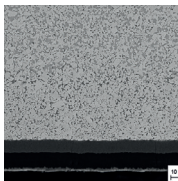
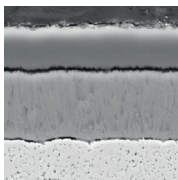
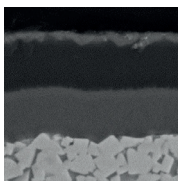
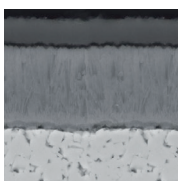
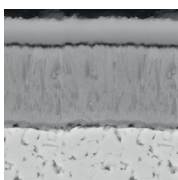
Grade	ISO	Micro structure	Grade description
<b>A</b>	Turning		P10 grade with excellent wear resistance at higher cutting speeds. Latest sinter processes and CVD coating technologies enable a wide range of applications in the P material range.
<b>B</b>	Milling		CVD coated P10–P20 carbide grade for finishing to medium operation of steel, casting steel and high chrome material. Outstanding performance under high cutting speed and temperature with excellent wear resistance.
<b>C</b>	Drilling		CVD coated P10–P20 carbide grade for finishing to medium operation of steel and casting steel. Outstanding performance under higher cutting speed and temperature with excellent wear resistance.
<b>D</b>	Technical Information		P20 grade with exceptional wear resistance and toughness for reliable machining operations. Ultra-modern sintering technique and CVD coating technologies allow for a wide range of applications in the P material range.
<b>E</b>	Index		CVD coated P20–P35 carbide grade for medium operation to roughing of steel and casting steel. Optimal performance of wear resistance and toughness for a wide application field.
<b>F</b>	Index		CVD coated P20–P40 carbide grade for roughing operation of steel and casting steel. Optimal performance of wear resistance and toughness for a wide application field.
<b>G</b>	Index		CVD coated M10–M25 carbide grade for finishing to medium application in stainless steel. High wear resistance and capability against plastic deformation at higher cutting speed.
<b>H</b>	Index		CVD coated M15–M35 carbide grade for medium to roughing operation in stainless steel with wide application field. High wear resistance and capability against plastic deformation at higher cutting speed.

**Coated cemented carbide CVD**

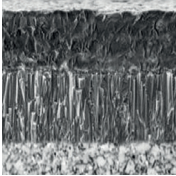
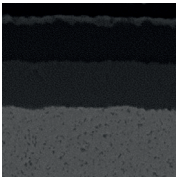
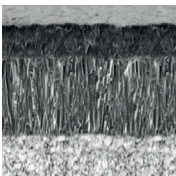
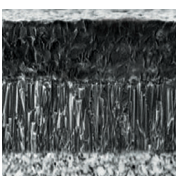
Grade	ISO	Micro structure	Grade description
<b>YBD102</b>	K05 - K20		CVD coated K05-K20 carbide substrate. Optimized for medium operation of cast iron, special nodular cast iron and hard steel at high cutting speed.
<b>YB7315</b>	K10 - K25		CVD coated K10-K25 carbide substrate. Optimized for medium to roughing operation of cast iron. Improved wear resistance and toughness at high cutting speed.
<b>YBD152</b>	K10 - K25		CVD coated K10-K25 carbide substrate. Optimized for medium to roughing operation of cast iron. Good wear resistance and toughness at higher cutting speed.
<b>YBD152C</b>	K10 - K25		Thick Al <sub>2</sub> O <sub>3</sub> CVD coated K05-K25 carbide substrate. Optimized for medium to roughing operation of cast iron. Higher wear resistance and toughness at higher cutting speed in combination with TC chip breaker.

**Coated cemented carbide PVD**

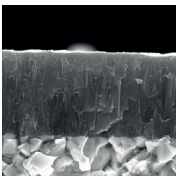
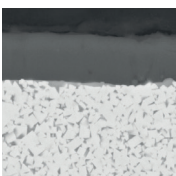
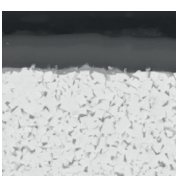
Grade	ISO	Micro structure	Grade description
<b>YBG101</b>	N05 - N20		PVD coated N05-N20 carbide substrate for finishing to semi-finishing in aluminium materials. Coating only on the top face, in combination with the aluminium chip breakers, prevents built-up edges and gives a smooth cut.
<b>YBG102</b>	S05 - S15		PVD coated S05-S15 carbide substrate for finishing to medium application of super alloy material, stainless steel and aluminum. Good wear resistance in a wide application field.
<b>YBG105</b>	S05 - S20		PVD multilayer coated S05-S20 carbide substrate for finishing to medium application of super alloy material but also stainless steel. Good wear resistance and thermal stability in a wide application field.

**A**

Turning

**B**

Milling

**C**

Drilling

**D**Technical  
Information**E**

Index

## Coated cemented carbide PVD

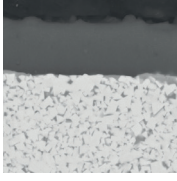
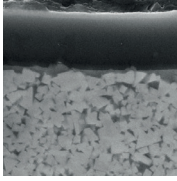
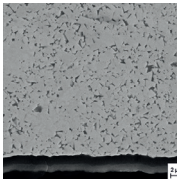
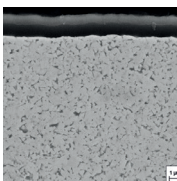
Grade	ISO	Micro structure	Grade description
<b>YBG205</b>	P10 - P30 M20 - M40 S15-S25		PVD multilayer coated P10–P30/M20–M40/S15–S25 carbide substrate for finishing to medium machining of stainless steel, super alloys and steel (milling). Excellent wear resistance and thermal stability in a wide range of applications.
<b>YB9320</b>	P10 - P30 M10 - M25		PVD multilayer coated P10–P30/M10–M25 carbide substrate for finishing to medium machining of stainless steel, super alloys and steel (grooving/milling). Optimised coating stability for higher wear resistance and thermal stability in a wide range of applications.
<b>YPD201</b>	S20 - S30		Carbide grade for semi-roughing to chip breaking of high-strength and high-alloy materials. High-performance grade with high wear resistance. Balanced hardness and internal stress ratio provide a wide range of applications.
<b>YBS103</b>	S10 - S20		Turning grade for processing nickel-base materials. A special carbide substrate and the latest PVD coating technology enable a very good wear behaviour and high thermal stability.

## Ceramic

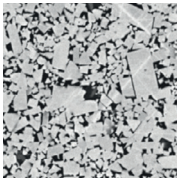
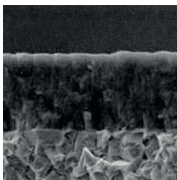
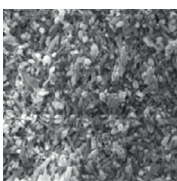
Grade	ISO	Micro structure	Grade description
<b>CA1000</b>	K10 - K25 H10 - H25		Uncoated H10–H25/K10–K25 mixed ceramic grade for finishing to medium operation in hardened steel and nodular cast iron. Good wear resistance and toughness.
<b>CM1000</b>	K10 - K25 H10 - H25		Coated H1–H25/K10–K25 mixed ceramic grade for finishing to medium operations in hardened steel, tool steel, HSS material and nodular cast iron. Good wear resistance and toughness.
<b>CN1000</b>	K05 - K15		Uncoated K05–K15 Si <sub>3</sub> N <sub>4</sub> ceramic grade for finishing to medium operation in grey cast iron. Good wear resistance and thermal stability.

**A**  
Turning

**B**  
Milling

**C**  
Drilling

**D**  
Technical Information

**E**  
Index

**Ceramic**

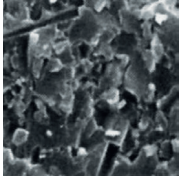
Grade	ISO	Micro structure	Grade description
<b>CS1000</b>	S05 – S20		Uncoated SiAlON ceramic grade for medium machining to roughing of nickel- and cobalt-based alloys at medium to low cutting speeds.
<b>CW1400</b>	S10 – S20 H10-H20		Uncoated whisker ceramic grade for medium and low speed cutting in HSS steel, high chrome steel and cobalt-base alloy also with interrupted cut. Good wear resistance, notch wear resistance and thermal stability.
<b>CW1800</b>	S10 – S25		Uncoated whisker ceramic grade for finishing to rough operations in Ni-base alloy material like Inconel, Nimonic or Hastelloy. Good wear resistance, notch wear resistance and thermal stability.

**Uncoated cemented carbide**

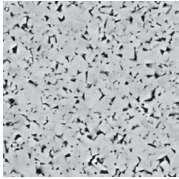
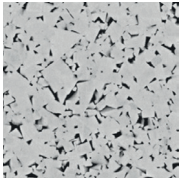
Grade	ISO	Micro structure	Grade description
<b>YD101</b>	N05 - N20 K05 - K20		Uncoated N05–N20/K05–K20 carbide substrate for fine to medium application in aluminum and other material.
<b>YD201</b>	N10 - N30 K10 - K30		Uncoated N10–N30/K10–K30 carbide substrate for medium application in aluminum and other material.

**CBN**

Grade	ISO	Micro structure	Grade description
<b>YCB112</b>	S10 – S20		Uncoated, brazed S10–S20 CBN grade for fine finishing operations on hardened steel and super alloys. Excellent wear resistance and thermal stability.

**A**

Turning

**B**

Milling

**C**

Drilling

**D**Technical  
Information**E**

Index



A	Turning
B	Milling
C	Drilling
D	Technical Information
E	Index

## CBN

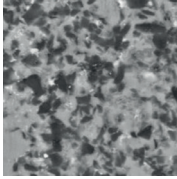
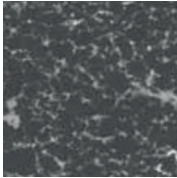
Grade	ISO	Micro structure	Grade description
<b>YCB113</b>	H01 - H10		Uncoated, brazed H01–H10 CBN grade for fine finishing operation in hardened steel with continuous cut. High wear resistance and productivity at higher cutting speed.
<b>YCB121</b>	H10 - H25		Uncoated, brazed H10–H25 CBN grade for fine to medium application in hardened steel from continuous to light interrupted cut. Good wear resistance and toughness for universal use.
<b>YCB131</b>	H20 - H35		Uncoated, brazed H20–H35 CBN grade for fine to medium application in hardened steel with interrupted cut. Good wear resistance and optimized toughness for safe process.
<b>YCB113C</b>	H01 - H10		Coated, brazed H01–H10 CBN grade for fine finishing operations on hardened steel with a continuous cut. High wear resistance and productivity at higher cutting speeds
<b>YCB121C</b>	H10 - H25		Coated, brazed H10–H25 CBN grade for fine to medium machining operations on hardened steel with a continuous to partially interrupted cut. Good wear resistance and toughness for universal application.
<b>YCB131C</b>	H20 - H25		Coated, brazed H20–H35 CBN grade for fine to medium machining operations on hardened steel with an interrupted cut. Good wear resistance and optimum toughness for reliable operations.
<b>YCB215</b>	K10 - K20		Uncoated, brazed K10–K20 CBN grade for fine to medium machining operations on cast iron. Excellent wear resistance and thermal conductivity.
<b>YZB630</b>	H20 - H30		Uncoated H20–H30 solid CBN grade for medium machining operations on hardened steel with a slight to medium interrupted cut. Excellent combination of wear resistance and thermal stability.

**CBN**

Grade	ISO	Micro structure	Grade description
<b>YZB630C</b>	H20 - H30		Coated H20–H30 solid CBN grade for medium machining operations on hardened steel with a slight to medium interrupted cut. Excellent combination of wear resistance and thermal stability.

<b>YZB223</b>	K10 - K25		Uncoated H10–H25/K10–K25 mixed ceramic grade for finishing to medium operation in hardened steel and nodular cast iron. Good wear resistance and toughness.
---------------	-----------	--	---

**PCD**

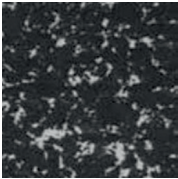
Grade	ISO	Micro structure	Grade description
<b>YCD421</b>	N01 - N10		Uncoated, brazed N01–N10 PCD grade for fine finishing operation of aluminum alloys less than 12 % Si, composites, copper/magnesium and other alloys. Medium grain size grade with good wear resistance for a wide application field.

**Cermet**

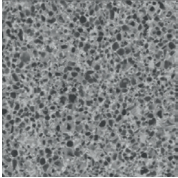
Grade	ISO	Micro structure	Grade description
<b>YNG151</b>	P05 - P15		Uncoated P05–P15 cermet grade for fine finishing operation of steel and stainless steel. Good resistance against plastic deformation for good surface finishing.

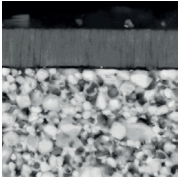
<b>YNG151C</b>	P05 - P15		PVD coated P05–P15 cermet grade for fine finishing operation of steel and stainless steel. Good wear resistance and capability against plastic deformation for good surface roughness.
----------------	-----------	---	--

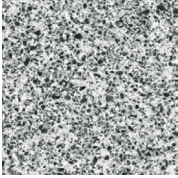
<b>YNT251</b>	P10 - P25		Uncoated P10–P25 cermet grade for fine finishing to medium operation of steel and stainless steel. Good wear resistance and toughness. Suitable also in light interrupted cut.
---------------	-----------	---	--

**A**

Turning

**B**

Milling

**C**

Drilling

**D**Technical  
Information**E**

Index

## CVD coated carbide grades for steel

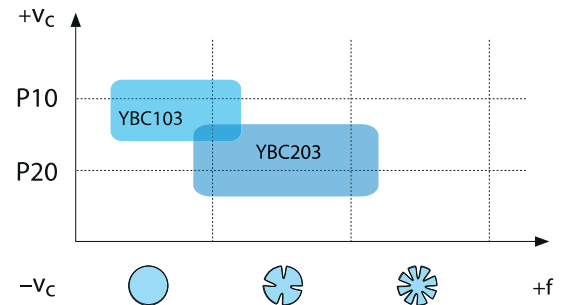
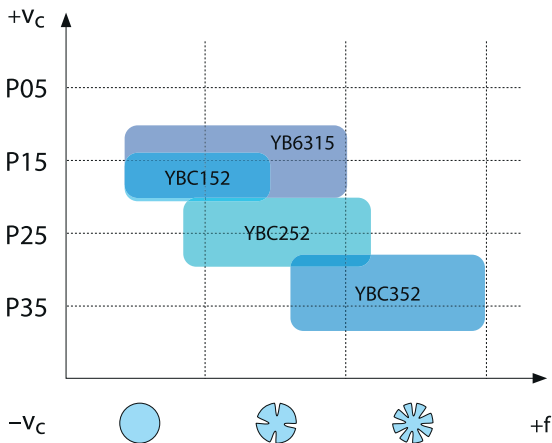

## Cermet grades for steel

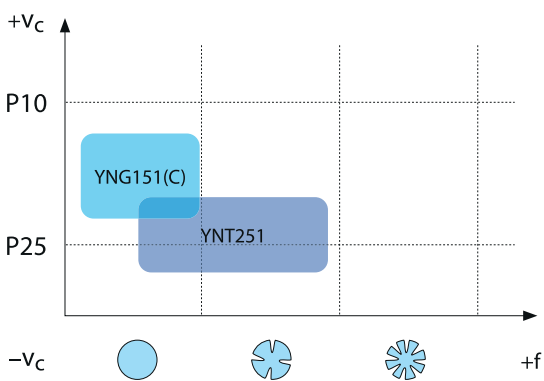

## CVD coated carbide grades for stainless steel

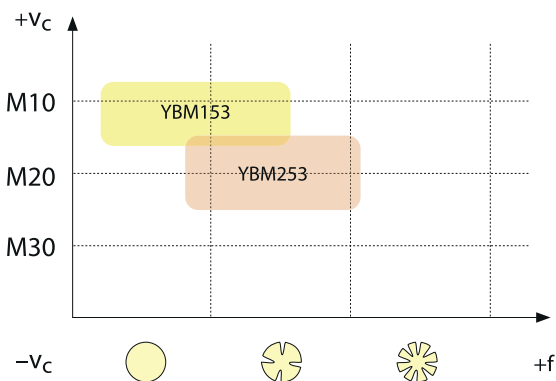

**A**

Turning

**B**

Milling

**C**

Drilling

**D**

Technical Information

**E**

Index

**PVD coated carbide grades for stainless steel**

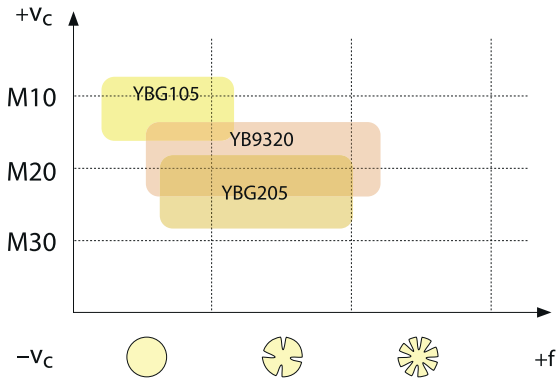

**CVD coated carbide grades for cast iron**

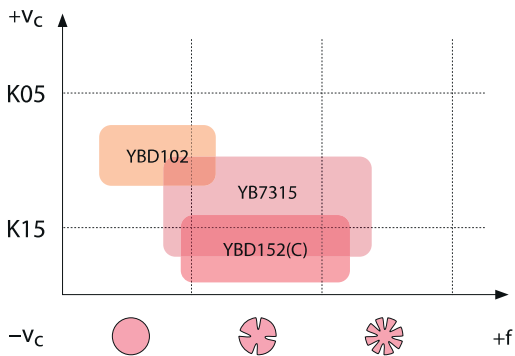

**CBN grades for cast iron**

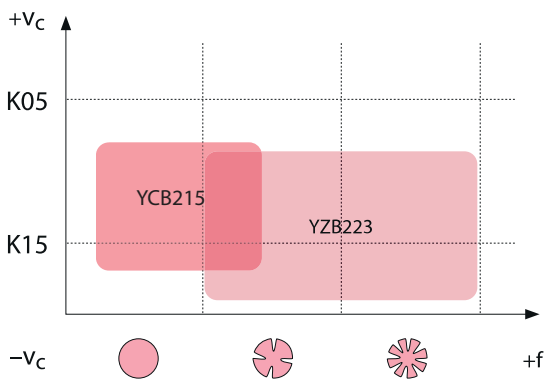

**A**

Turning

**B**

Milling

**C**

Drilling

**D**

Technical Information

**E**

Index

**A**

Turning

## Ceramic grades for cast iron

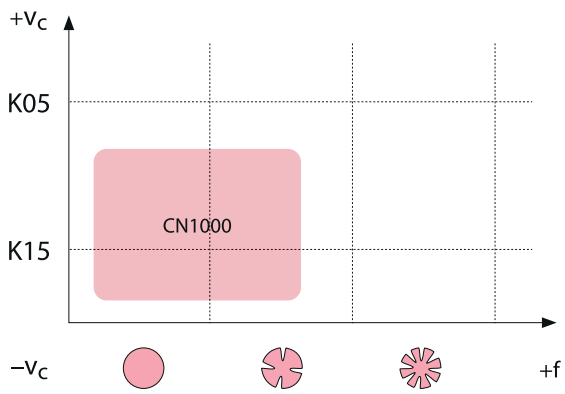

**B**

Milling

## PVD coated carbide grades for superalloys

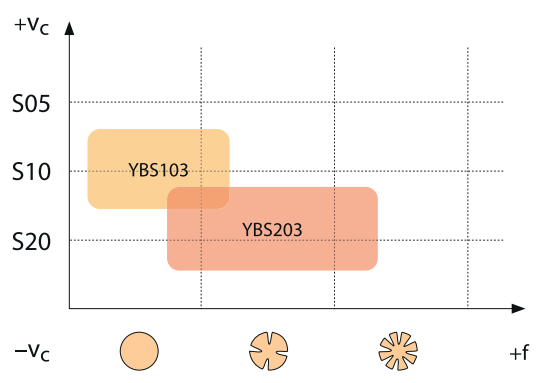
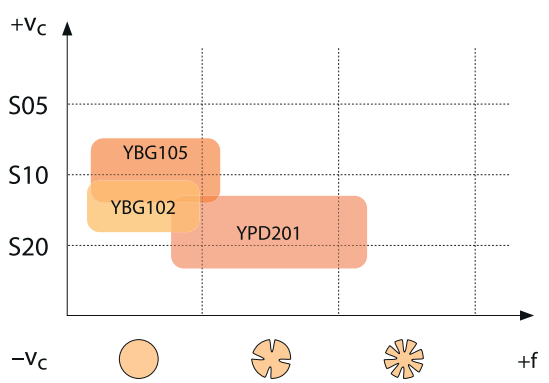

**C**

Drilling

**D**

Technical Information

## Ceramic grades for cobalt base alloys/HSS

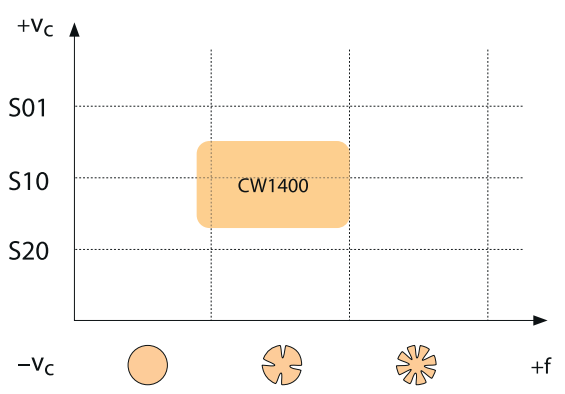

**E**

Index

**Ceramic grades for nickel base alloys**

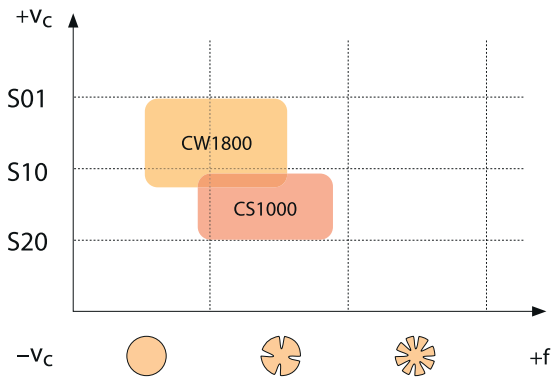

**CBN grades for superalloys**

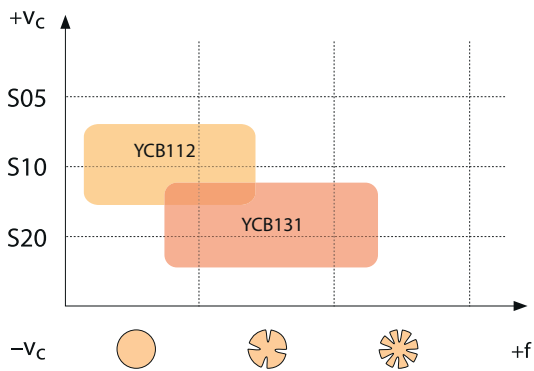

**Carbide grades for non-ferrous metals**

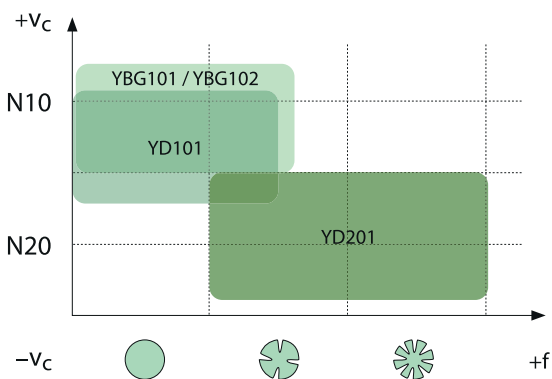

**A**

Turning

**B**

Milling

**C**

Drilling

**D**

Technical  
Information

**E**

Index

**A**

Turning

## PCD grades for non-ferrous metals

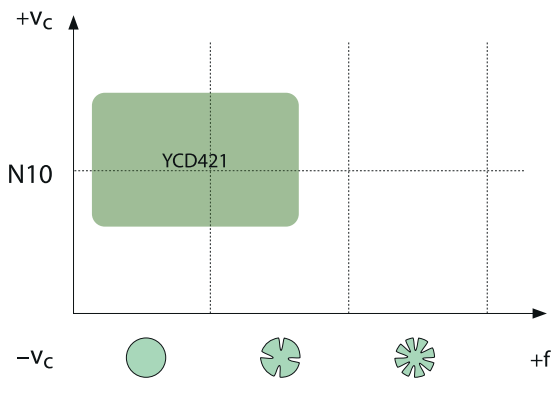

**B**

Milling

## CBN grades for hardened steel

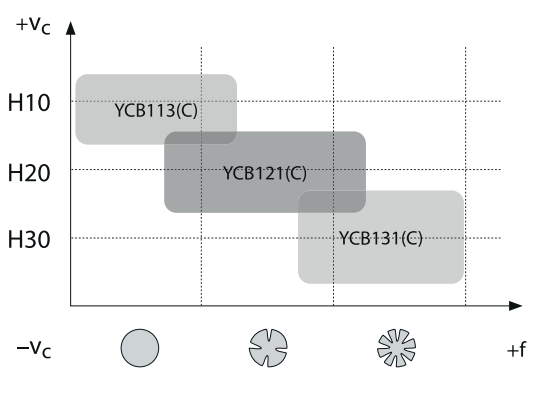

**C**

Drilling

**D**

Technical Information

## Ceramic grades for hardened steel

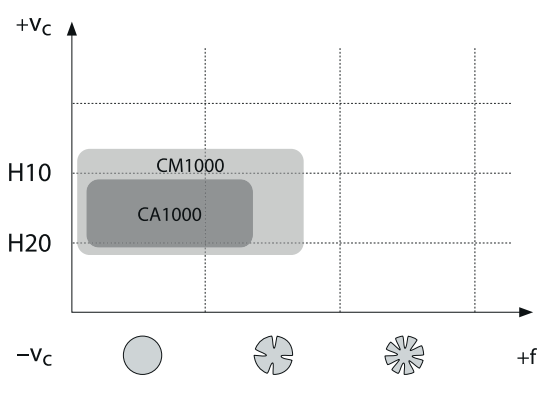

**E**

Index

Application fields of grades – general turning

	ISO	HC <sup>1</sup> (CVD)	HC <sup>1</sup> (PVD)	HT	HC <sup>2</sup>	Ceramic	HW	CBN	PCD
<b>P</b>	P01	YBC103		YNG151	YNG151C				
	P10	YB6315		YNT251					
	P20	YBC152							
	P30	YBC203							
	P40	YBC252							
		YBC352							
<b>M</b>	M01		YBG105	YNG151	YNG151C				
	M10	YBM153	YB9320						
	M20	YBM253	YBG205						
	M30								
	M40								
<b>K</b>	K01					CN1000		YCB215	YZB223
	K10	YBD102					YD201		
	K20	YBD152							
	K30	YB7315							
		YBD152C							
<b>N</b>	N01						YD101		YCD421
	N10		YBG101				YD201		
	N20		YBG102						
	N30								
<b>S</b>	S01		YBS103			CS1000		YCB112	
	S10		YBG102			CW1400		YCB131	
	S20		YBG105			CW1800			
	S30		YB9320	YPD201					
<b>H</b>	H01							YCB113(C)	
	H10							YCB121(C)	
	H20								YCB131(C)
	H30								

<b>P</b>	Steel
<b>M</b>	Stainless steel
<b>K</b>	Cast iron

<b>N</b>	Non-ferrous metals
<b>S</b>	Heat-resistant alloys
<b>H</b>	Hardened materials

HC<sup>1</sup> Coated carbide  
 HT Uncoated cermet  
 HC<sup>2</sup> Coated cermet  
 HW Uncoated carbide

**A**

Turning

**B**

Milling

**C**

Drilling

**D**

Technical Information

**E**

Index



## ISO standard

**T N M G 22 04 08 (N) – DM**

**1 2 3 4 5 6 7 8 9**

Insert shape		
A	B	C
D	E	H
K	L	M
O	P	R
S	T	V
W	Z Special	

Clearance angle	
A	B
C	D
E	F
G	N
P	O Special

Tolerance class			
Code	I.C [mm]	m [mm]	S [mm]
A	±0,025	±0,005	±0,025
C	±0,025	±0,013	±0,025
E	±0,025	±0,025	±0,025
F	±0,013	±0,005	±0,025
G	±0,025	±0,025	±0,130
H	±0,013	±0,013	±0,025
J	±0,05–0,15	±0,005	±0,025
K	±0,05–0,15	±0,013	±0,025
L	±0,05–0,15	±0,025	±0,025
M	±0,05–0,15	±0,08–0,20	±0,130
N	±0,05–0,15	±0,08–0,20	±0,025
U	±0,08–0,25	±0,13–0,38	±0,130

**1**

**2**

**3**

Fastening features (metric)	
Insert shape	
A	B
C	F
G	H
J	M
N	Q
R	T
U	W
X Special	

Cutting edge length l [mm]								
I.C [mm]	Insert shape							
	C	D	R	S	T	V	W	K
3,97	06							
5,0	05							
5,56	09							
6,0	06							
6,35	06	07			11	11		
8,0	08							
9,525	09	11	09	09	16	16	06	16
10,0	10							
12,0	12							
12,7	12	15	12	12	22	22	08	
15,875	16		15	15	27			
16,0	19							
19,05	19		19	19	33			
20,0	20							
25,0	25	25	25					
25,4	25 25							
31,75	31							
32	32							

**4**

**5**

Insert thickness S [mm]			
Code	S	Code	S
00	0,79	T5	5,95
T0	0,99	06	6,35
01	1,59	T6	6,75
T1	1,98	07	7,94
02	2,38	09	9,52
T2	2,58	T9	9,72
03	3,18	11	11,11
T3	3,97	12	12,70
04	4,76		
T4	4,96		
05	5,56		

6

Nose radius r [mm]	
Code	r
00	–
02	0,2
04	0,4
08	0,8
12	1,2
16	1,6
20	2,0
24	2,4
32	3,2
X	Special
MO	Round inserts

7

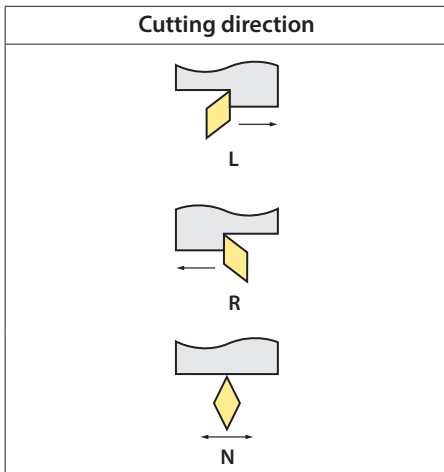

8

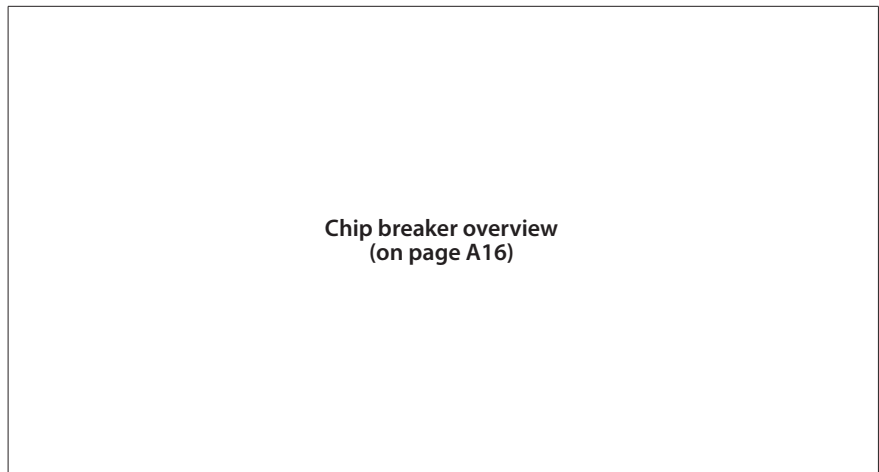

9

**ANSI standard**

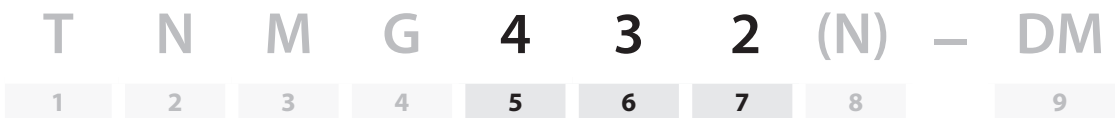

Inner circle		
Code	[mm]	Pouce
2	6.35	0.250
3	9.525	0.375
4	12.7	0.500
5	15.875	0.625
6	19.05	0.750
8	25.4	1.000

5

Insert thickness		
Code	[mm]	Pouce
2	3.18	0.125
3	4.76	0.187
4	6.35	0.250
5	7.94	0.313
6	9.52	0.375



6

Nose radius		
Code	[mm]	Pouce
0	0.2	0.008
1	0.4	0.016
2	0.8	0.031
3	1.2	0.047
4	1.6	0.063
5	2.0	0.079
6	2.4	0.094

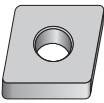
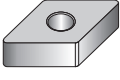

7

## Conversion table for general turning inserts (metric/imperial system)



Negative angle/insert

	ISO	Inch
Insert shape C 	090304	321
	090308	322
	120404	431
	120408	432
	120412	433
	120416	434
	160608	542
	160612	543
	160616	544
	190608	642
	190612	643
	190616	644
	190624	646
	250724	856
	250732	858
	250924	866
250932	868	
Insert shape D 	110404	331
	110408	332
	110412	333
	150404	431
	150408	432
	150412	433
	150604	441
	150608	442
	150612	443
	190608	542
190612	543	
Insert shape V 	160404	331
	160408	332
	160412	333
Insert shape R 	0903MO	32
	1204MO	43

Positive angle/insert

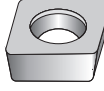
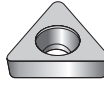
	ISO	Inch
Insert shape W 	06T304	3(2.5)1
	06T308	3(2.5)2
	06T312	3(2.5)3
	060404	331
	060408	332
	060412	333
	080404	431
	080408	432
	080412	433
Insert shape T 	113304	221
	110308	222
	160404	331
	160408	332
	160412	333
	220404	431
	220408	432
	220412	433
	220416	434
	270608	542
270612	543	
270616	544	
Insert shape S 	090304	321
	090308	322
	090312	323
	120404	431
	120408	432
	120412	433
	120416	434
	150608	542
	150612	543
	150616	544
	190412	633
	190424	636
	190612	643
	190616	644
	250724	856
	250732	858
250924	866	
250932	868	

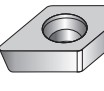
	ISO	Inch
Insert shape C 	060202	2(1.5)0
	060204	2(1.5)1
	060208	2(1.5)2
	09T302	3(2.5)0
	09T304	3(2.5)1
	09T308	3(2.5)2
	120404	431
	120408	432
	120412	433
Inserts shape T 	06T102	1.2(1.2)0
	06T104	1.2(1.2)1
	06T108	1.2(1.2)2
	090202	1.8(1.5)0
	090204	1.8(1.5)1
	090208	1.8(1.5)2
	110202	2(1.5)0
	110204	2(1.5)1
	110208	2(1.5)2
	110302	220
	110304	221
	110308	222
	16T302	30
	16T304	31
	16T308	32
	16T312	33
160400	330	
220408	432	
220412	433	
220416	434	
270408	532	
270412	533	
330612	643	
330616	644	

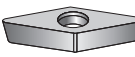
	ISO	Inch
Insert shape D 	070202	2(1.5)0
	070204	2(1.5)1
	070208	2(1.5)2
	11T302	3(2.5)0
	11T304	3(2.5)1
	11T308	3(2.5)2
	11T312	3(2.5)3
Insert shape S 	060204	2(1.5)1
	09T302	3(2.5)0
	09T304	3(2.5)1
	09T308	3(2.5)2
	120404	431
	120408	432
	120412	433
	150404	531
150408	532	
150412	533	
190408	632	
190412	633	
190416	634	
Inserts shape V 	110202	2(1.5)0
	110204	2(1.5)1
	110208	2(1.5)2
	110302	220
	110304	221
	110308	222
	160402	330
	160404	331
160408	332	
160412	333	

A

Turning

B

Milling

C

Drilling

D

Technical Information

E

Index

- Ideal machining conditions
- Normal machining conditions
- Unfavourable machining conditions

CNMG	L	I.C	S	d
<b>09 03</b>	9.7	9.525	3.18	3.81
<b>12 04</b>	12.9	12.7	4.76	5.16

**Turning inserts**

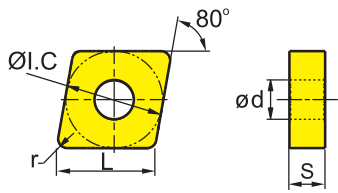

CN** negative insert				HC <sup>1</sup> (CVD)								HC <sup>1</sup> (PVD)			HT	HC <sup>2</sup>	HW											
ISO	r	a <sub>p</sub>	f	YBC103	YB6315	YBC152	YBC203	YBC252	YBC352	YBM153	YBM253	YBD102	YB7315	YBD152	YBD152C	YBG101	YBG102	YBG105	YBG205	YB9320	YPD201	YBS103	YNG151	YNT251	YNG151C	YD101	YD201	
<b>WG</b>  Wiper	<b>CNMG120404-WG</b>	0.4	0.25-3.00	0.05-0.25																								
	<b>CNMG120408-WG</b>	0.8	0.5-5.0	0.15-0.70		●		●						○														
	<b>CNMG120412-WG</b>	1.2	0.8-6.0	0.20-0.75		●																						
<b>ADF</b>  Finishing	<b>CNMG120404-ADF</b>	0.4	0.5-3.0	0.05-0.30	●													●	●									
	<b>CNMG120408-ADF</b>	0.8	0.5-3.0	0.1-0.4	●													○	●					●				
	<b>CNMG120412-ADF</b>	1.2	0.8-3.0	0.15-0.50	○														●					●				
<b>DF</b>  Finishing	<b>CNMG090304-DF</b>	0.4	0.25-1.50	0.07-0.30		●		●																				
	<b>CNMG090308-DF</b>	0.8	0.3-1.5	0.1-0.3		●		○																				
	<b>CNMG120404-DF</b>	0.4	0.25-1.50	0.07-0.30		●		●																				
	<b>CNMG120408-DF</b>	0.8	0.3-1.5	0.1-0.4		●		●																				
	<b>CNMG120412-DF</b>	1.2	0.35-1.50	0.10-0.35		●		●																				
<b>EF</b>  Finishing	<b>CNMG090304-EF</b>	0.4	0.5-2.0	0.05-0.20														●										
	<b>CNMG090308-EF</b>	0.8	0.5-2.0	0.05-0.25														●										
	<b>CNMG120404-EF</b>	0.4	0.5-2.5	0.05-0.20														●										
	<b>CNMG120408-EF</b>	0.8	0.5-2.5	0.05-0.25														●										
	<b>CNMG120412-EF</b>	1.2	0.5-2.5	0.10-0.35														○										
<b>SF</b>  Finishing	<b>CNMG090304-SF</b>	0.4	0.05-0.50	0.05-0.30																					●			
	<b>CNMG120404-SF</b>	0.4	0.1-1.5	0.05-0.30																					●			
	<b>CNMG120408-SF</b>	0.8	0.1-1.5	0.10-0.35																					●			

● Ex stock ○ On demand  
YBC152F, YBC252F, YBM153F, YBM253F available

HC<sup>1</sup> Coated carbide  
HT Uncoated cermet  
HC<sup>2</sup> Coated cermet  
HW Uncoated carbide

Tool holder					
DCLNR/L	PCBNR/L	PCLNR/L	MCBNR/L	MCLNR/L	A***-PCLNR/L
Kr: 95°	Kr: 75°	Kr: 95°	Kr: 75°	Kr: 95°	Kr: 95°
A230	A237	A238	A252	A253	A324

System code > A48    Grade selection > A42    Technical info > A501    Cutting data > A366



**A** Turning  
**B** Milling  
**C** Drilling  
**D** Technical Information  
**E** Index

**A**

Turning

- Ideal machining conditions
- ⊗ Normal machining conditions
- ⊗ Unfavourable machining conditions

CN**	L	I.C	S	d
12 04	12.9	12.7	4.76	5.16

## Turning inserts

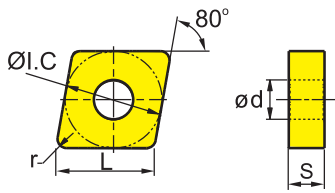

CN** negative insert					HC <sup>1</sup> (CVD)								HC <sup>1</sup> (PVD)			HT	HC <sup>2</sup>	HW															
					P	●	●	●	⊗	⊗	⊗																						
					M				●	⊗		●	●	●	●	●																	
					K																												
					N							●	●			●	⊗																
					S												●	⊗															
					H																												
ISO					r	a <sub>p</sub>	f	YBC103	YB6315	YBC152	YBC203	YBC252	YBC352	YBM153	YBM253	YBD102	YB7315	YBD152	YBD152C	YBG101	YBG102	YBG105	YBG205	YB9320	YPD201	YBS103	YNG151	YNT251	YNG151C	YD101	YD201		
NF	<b>CNEG120404-NF</b>				0.4	0.2-2.5	0.05-0.30														○	●								○			
	<b>CNEG120408-NF</b>				0.8	0.2-2.5	0.10-0.35															○	●							○			
	<b>CNEG120412-NF</b>				1.2	0.2-2.5	0.13-0.40															○	●							○			
XF	<b>CNMG120404-XF</b>				0.4	0.5-2.5	0.1-0.25	●			●																						
	<b>CNMG120408-XF</b>				0.8	0.5-2.5	0.1-0.30	●			●																						
	<b>CNMG120412-XF</b>				1.2	0.5-2.5	0.1-0.35	●			●																						

● Ex stock    ○ On demand

HC<sup>1</sup> Coated carbide  
 HT Uncoated cermet  
 HC<sup>2</sup> Coated cermet  
 HW Uncoated carbide

**B**

Milling

**C**

Drilling

**D**

Technical Information

**E**

Index

Tool holder					
DCLNR/L	PCBNR/L	PCLNR/L	MCBNR/L	MCLNR/L	S***-PCLNR/L
Kr: 95°	Kr: 75°	Kr: 95°	Kr: 75°	Kr: 95°	Kr: 95°
A230	A237	A238	A252	A253	A324

System code > A48

Grade selection > A42

Technical info > A501



Cutting data > A366



CNMG	L	I.C	S	d
09 03	9.7	9.525	3.18	3.81
12 04	12.9	12.7	4.76	5.16
16 06	16.1	15.875	6.35	6.35
19 06	19.3	19.05	6.35	7.94

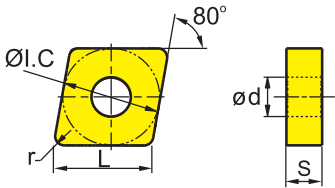

- Ideal machining conditions
- ⊗ Normal machining conditions
- ⊗ Unfavourable machining conditions

**Turning inserts**

CN** negative insert				HC <sup>1</sup> (CVD)								HC <sup>1</sup> (PVD)			HT	HC <sup>2</sup>	HW											
				P	M	K	N	S	H																			
																												
ISO	r	a <sub>p</sub>	f	YBC103	YB6315	YBC152	YBC203	YBC252	YBC352	YBM153	YBM253	YBD102	YB7315	YBD152	YBD152C	YBG101	YBG102	YBG105	YBG205	YB9320	YPD201	YBS103	YNG151	YNT251	YNG151C	YD101	YD201	
<b>PM</b>  Medium Cut	CNMG090304-PM	0.4	0.4-4.0	0.1-0.3					●																			
	CNMG090308-PM	0.8	0.5-4.0	0.15-0.50					●																			
	CNMG120404-PM	0.4	0.4-5.5	0.1-0.3		●						●																
	CNMG120408-PM	0.8	0.5-5.5	0.15-0.50		●					●																	
	CNMG120412-PM	1.2	0.8-5.5	0.18-0.60		●					●																	
	CNMG120416-PM	1.6	1.0-5.5	0.23-0.65		●					●																	
	CNMG160608-PM	0.8	0.5-7.2	0.15-0.50		○				●			○		○													
	CNMG160612-PM	1.2	0.8-7.2	0.18-0.60		●					●				●													
	CNMG160616-PM	1.6	1.0-7.2	0.23-0.65		●					●				○													
	CNMG190608-PM	0.8	0.5-8.6	0.15-0.50						●																		
	CNMG190612-PM	1.2	0.8-8.6	0.18-0.60						●			○		●													
	CNMG190616-PM	1.6	1.0-8.6	0.23-0.65						○					○													
<b>XM</b>  Medium Cut	CNMG120404-XM	0.4	1-4.2	0.2-0.3	●		○																					
	CNMG120408-XM	0.8	1-4.2	0.2-0.4	●		●																					
	CNMG120412-XM	1.2	1-4.2	0.2-0.6	●		●																					
	CNMG120416-XM	1.6	1-4.2	0.2-0.65	●		●																					
	CNMG160608-XM	0.8	1-5.6	0.2-0.4	●		●																					
	CNMG160612-XM	1.2	1-5.6	0.2-0.6	●		●																					
	CNMG160616-XM	1.6	1-5.6	0.2-0.65	○		●																					
	CNMG190608-XM	0.8	1-6.65	0.2-0.4	●		●																					
CNMG190612-XM	1.2	1-6.65	0.2-0.6	○		●																						
CNMG190616-XM	1.6	1-6.65	0.2-0.65	○		●																						

● Ex stock ○ On demand  
 YBC152F, YBC252F, YBM153F, YBM253F available

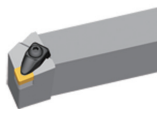
HC<sup>1</sup> Coated carbide  
 HT Uncoated cermet  
 HC<sup>2</sup> Coated cermet  
 HW Uncoated carbide

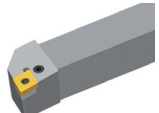
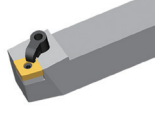
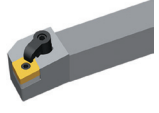
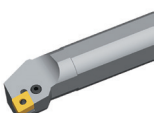
Tool holder					
DCLNR/L	PCBNR/L	PCLNR/L	MCBNR/L	MCLNR/L	A***-PCLNR/L
Kr: 95°	Kr: 75°	Kr: 95°	Kr: 75°	Kr: 95°	Kr: 95°
					
A230	A237	A238	A252	A253	A324

System code > A48    Grade selection > A42    Technical info > A501    Cutting data > A366



A Turning  
 B Milling  
 C Drilling  
 D Technical Information  
 E Index

**A**

Turning

**B**

Milling

**C**

Drilling

**D**

Technical Information

**E**

Index

CNMG	L	I.C	S	d
09 03	9.7	9.525	3.18	3.81
12 04	12.9	12.7	4.76	5.16
16 06	16.1	15.875	6.35	6.35
19 06	19.3	19.05	6.35	7.94

- Ideal machining conditions
- ● Normal machining conditions
- ● ● Unfavourable machining conditions

## Turning inserts

CN** negative insert				HC <sup>1</sup> (CVD)										HC <sup>1</sup> (PVD)		HT	HC <sup>2</sup>	HW												
	P	M	K	N	S	H																								
	ISO	r	a <sub>p</sub>	f	YBC103	YB6315	YBC152	YBC203	YBC252	YBC352	YBM153	YBM253	YBD102	YB7315	YBD152	YBD152C	YBG101	YBG102	YBG105	YBG205	YB9320	YPD201	YBS103	YNG151	YNT251	YNG151C	YD101	YD201		
	<b>DM</b>  Medium Cut	CNMG090304-DM	0.4	0.4-4.0	0.1-0.3	●	●																							
		CNMG090308-DM	0.8	0.5-4.0	0.15-0.50	●	●																							
		CNMG090312-DM	1.2	0.5-3.0	0.1-0.4				○																					
		CNMG120404-DM	0.4	0.4-5.5	0.1-0.3	●	●																							
CNMG120408-DM		0.8	0.5-5.5	0.15-0.50	○	●	●	○	●																					
CNMG120412-DM		1.2	0.8-5.5	0.18-0.60	○	●	●		○																					
CNMG120416-DM		1.6	1.0-5.5	0.23-0.65	○	●																								
CNMG160608-DM		0.8	0.5-7.2	0.15-0.50	○	●																								
CNMG160612-DM		1.2	0.8-7.2	0.18-0.60	●	●																								
CNMG160616-DM		1.6	1.0-7.2	0.23-0.65	●	●																								
CNMG190608-DM		0.8	0.5-8.6	0.15-0.50	●	●																								
CNMG190612-DM		1.2	0.8-8.6	0.18-0.60	●	●																								
CNMG190616-DM		1.6	1.0-8.6	0.23-0.65		●																								
<b>EG</b>  Medium Cut		CNMG120404-EG	0.4	0.5-4.0	0.05-0.30						●	●								○	●									
	CNMG120408-EG	0.8	0.5-4.0	0.1-0.4						●	●									●	●									
	CNMG120412-EG	1.2	0.5-4.0	0.2-0.5							●									●	●									
<b>EM</b>  Medium Cut	CNMG120404-EM	0.4	0.5-4.0	0.05-0.30						●	●								●											
	CNMG120408-EM	0.8	0.5-5.7	0.15-0.45						●	●									●										
	CNMG120412-EM	1.2	0.5-5.7	0.25-0.60						●	●									●										
	CNMG160608-EM	0.8	0.5-7.2	0.15-0.45						●	●									●										
	CNMG160612-EM	1.2	0.5-7.2	0.25-0.60						●	●									●										

● Ex stock   ○ On demand  
 YBC152F, YBC252F, YBM153F, YBM253F available

HC<sup>1</sup> Coated carbide  
 HT Uncoated cermet  
 HC<sup>2</sup> Coated cermet  
 HW Uncoated carbide

Tool holder					
DCLNR/L	PCBNR/L	PCLNR/L	MCBNR/L	MCLNR/L	A***-PCLNR/L
Kr: 95°	Kr: 75°	Kr: 95°	Kr: 75°	Kr: 95°	Kr: 95°
A230	A237	A238	A252	A253	A324

System code > A48   Grade selection > A42   Technical info > A501   Cutting data > A366



- Ideal machining conditions
- ⊗ Normal machining conditions
- ⊗ Unfavourable machining conditions

CNMG	L	I.C	S	d
12 04	12.9	12.7	4.76	5.16

**Turning inserts**

CN** negative insert				HC <sup>1</sup> (CVD)								HC <sup>1</sup> (PVD)			HT	HC <sup>2</sup>	HW										
				<b>P</b>	●	●	●	●	⊗	⊗					●	⊗	●										
				<b>M</b>					●	⊗			●	●	⊗	⊗	●	⊗	●								
				<b>K</b>								⊗	⊗	⊗	⊗												
				<b>N</b>									●	●					●	⊗							
				<b>S</b>										●	●	⊗	⊗	●		●	⊗						
				<b>H</b>																							
ISO	r	a <sub>p</sub>	f	YBC103	YB6315	YBC152	YBC203	YBC252	YBC352	YBM153	YBM253	YBD102	YB7315	YBD152	YBD152C	YBG101	YBG102	YBG105	YBG205	YB9320	YPD201	YBS103	YNG151	YNT251	YNG151C	YD101	YD201
ZM	<b>CNMG120404-ZM</b>	0.4	0.5-3.0	0.05-0.30	●																						
	<b>CNMG120408-ZM</b>	0.8	0.5-4.0	0.1-0.5	○																						
Medium Cut																											

● Ex stock ○ On demand

HC<sup>1</sup> Coated carbide  
 HT Uncoated cermet  
 HC<sup>2</sup> Coated cermet  
 HW Uncoated carbide

Tool holder					
DCLNR/L	PCBNR/L	PCLNR/L	MCBNR/L	MCLNR/L	S***-PCLNR/L
Kr: 95°	Kr: 75°	Kr: 95°	Kr: 75°	Kr: 95°	Kr: 95°
A230	A237	A238	A252	A253	A324

System code > A48

Grade selection > A42

Technical info > A501

Cutting data > A366



A

Turning

B

Milling

C

Drilling

D

Technical Information

E

Index



# General turning Negative inserts

A

Turning

- Ideal machining conditions
- ⊗ Normal machining conditions
- ⊗ Unfavourable machining conditions

CNMG	L	I.C	S	d
12 04	12.9	12.7	4.76	5.16
16 06	16.1	15.875	6.35	6.35

## Turning inserts

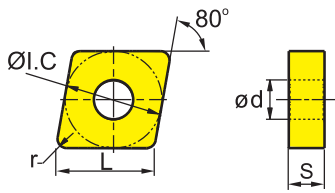

CN** negative insert					HC <sup>1</sup> (CVD)										HC <sup>1</sup> (PVD)			HT	HC <sup>2</sup>	HW								
					P										M			K	N	S	H							
	ISO	r	a <sub>p</sub>	f	YBC103	YB6315	YBC152	YBC203	YBC252	YBC352	YBM153	YBM253	YBD102	YB7315	YBD152	YBD152C	YBG101	YBG102	YBG105	YBG205	YB9320	YPD201	YBS103	YNG151	YNT251	YNG151C	YD101	YD201
<b>NM</b>  Medium Cut	<b>CNMG120404-NM</b>	0.4	0.2-3.0	0.05-0.30													○	●										
	<b>CNMG120408-NM</b>	0.8	0.2-4.0	0.1-0.5														○	●	●	●						○	
	<b>CNMG120412-NM</b>	1.2	0.2-4.0	0.2-0.6														○	●									
<b>TC</b>  Medium Cut	<b>CNMG120404-TC</b>	0.4	0.5-5.0	0.08-0.40									●	●														
	<b>CNMG120408-TC</b>	0.8	0.5-5.0	0.15-0.50									●	●														
	<b>CNMG120412-TC</b>	1.2	0.5-5.0	0.2-0.6									●	●														
	<b>CNMG120416-TC</b>	1.6	0.5-5.0	0.20-0.65									●	○														
	<b>CNMG160608-TC</b>	0.8	1-7	0.15-0.50									●	●														
	<b>CNMG160612-TC</b>	1.2	1-7	0.2-0.6									●	●														
<b>TK</b>  Medium Cut	<b>CNMG120408-TK</b>	0.8	0.2-0.4	0.2-0.4									○															
	<b>CNMG120412-TK</b>	1.2	0.2-0.4	0.2-0.45									○															
	<b>CNMG120416-TK</b>	1.6	0.2-0.4	0.2-0.5									●															

● Ex stock   ○ On demand

HC<sup>1</sup> Coated carbide  
 HT Uncoated cermet  
 HC<sup>2</sup> Coated cermet  
 HW Uncoated carbide

D

Technical Information

Tool holder					
DCLNR/L	PCBNR/L	PCLNR/L	MCBNR/L	MCLNR/L	S***-PCLNR/L
Kr: 95°	Kr: 75°	Kr: 95°	Kr: 75°	Kr: 95°	Kr: 95°
A230	A237	A238	A252	A253	A324

E

Index

System code > A48

Grade selection > A42

Technical info > A501

Cutting data > A366

CNMG	L	I.C	S	d
12 04	12.9	12.7	4.76	5.16
16 06	16.1	15.875	6.35	6.35
19 06	19.3	19.05	6.35	7.94
25 09	25.79	25.4	9.525	9.12

- Ideal machining conditions
- ⊗ Normal machining conditions
- ⊗ Unfavourable machining conditions

**Turning inserts**

CN** negative insert				HC <sup>1</sup> (CVD)								HC <sup>1</sup> (PVD)			HT	HC <sup>2</sup>	HW																																																																																																																																																																																																																																																																																																																																																																																																																																																																													
				P	M	K	N	S	H																																																																																																																																																																																																																																																																																																																																																																																																																																																																																					
				<table border="1"> <thead> <tr> <th>ISO</th> <th>r</th> <th>a<sub>p</sub></th> <th>f</th> <th>YBC103</th> <th>YB6315</th> <th>YBC152</th> <th>YBC203</th> <th>YBC252</th> <th>YBC352</th> <th>YBM153</th> <th>YBM253</th> <th>YBD102</th> <th>YB7315</th> <th>YBD152</th> <th>YBD152C</th> <th>YBG101</th> <th>YBG102</th> <th>YBG105</th> <th>YBG205</th> <th>YB9320</th> <th>YPD201</th> <th>YBS103</th> <th>YNG151</th> <th>YNT251</th> <th>YNG151C</th> <th>YD101</th> <th>YD201</th> </tr> </thead> <tbody> <tr> <td rowspan="10">DR  Roughing</td> <td>CNMG120408-DR</td> <td>0.8</td> <td>0.7-7.0</td> <td>0.2-0.5</td> <td>○</td> <td>●</td> <td>●</td> <td>●</td> <td>●</td> <td>●</td> <td>●</td> <td>●</td> <td>●</td> <td>●</td> <td>●</td> <td></td> <td></td> <td></td> <td></td> <td></td> <td></td> <td></td> <td></td> <td></td> <td></td> <td></td> <td></td> <td></td> </tr> <tr> <td>CNMG120412-DR</td> <td>1.2</td> <td>1-7</td> <td>0.25-0.70</td> <td>○</td> <td>●</td> <td>●</td> <td>●</td> <td>●</td> <td>●</td> <td>●</td> <td>●</td> <td>●</td> <td>●</td> <td>●</td> <td></td> <td></td> <td></td> <td></td> <td></td> <td></td> <td></td> <td></td> <td></td> <td></td> <td></td> <td></td> <td></td> </tr> <tr> <td>CNMG120416-DR</td> <td>1.6</td> <td>1.5-7.0</td> <td>0.32-0.75</td> <td></td> <td>○</td> <td>●</td> <td>●</td> <td>●</td> <td>●</td> <td>●</td> <td>●</td> <td>○</td> <td>●</td> <td>●</td> <td></td> <td></td> <td></td> <td></td> <td></td> <td></td> <td></td> <td></td> <td></td> <td></td> <td></td> <td></td> <td></td> <td></td> </tr> <tr> <td>CNMG160608-DR</td> <td>0.8</td> <td>0.7-8.0</td> <td>0.2-0.5</td> <td></td> <td></td> <td>●</td> <td>●</td> <td>●</td> <td>●</td> <td>●</td> <td>●</td> <td>○</td> <td>●</td> <td>●</td> <td></td> <td></td> <td></td> <td></td> <td></td> <td></td> <td></td> <td></td> <td></td> <td></td> <td></td> <td></td> <td></td> <td></td> </tr> <tr> <td>CNMG160612-DR</td> <td>1.2</td> <td>1-8</td> <td>0.25-0.70</td> <td>○</td> <td>●</td> <td>●</td> <td>●</td> <td>●</td> <td>●</td> <td>●</td> <td>●</td> <td>●</td> <td>●</td> <td>●</td> <td></td> <td></td> <td></td> <td></td> <td></td> <td></td> <td></td> <td></td> <td></td> <td></td> <td></td> <td></td> <td></td> <td></td> </tr> <tr> <td>CNMG160616-DR</td> <td>1.6</td> <td>1.5-8.0</td> <td>0.3-0.8</td> <td>○</td> <td>●</td> <td>●</td> <td>●</td> <td>●</td> <td>●</td> <td>●</td> <td>●</td> <td>○</td> <td>●</td> <td>●</td> <td></td> <td></td> <td></td> <td></td> <td></td> <td></td> <td></td> <td></td> <td></td> <td></td> <td></td> <td></td> <td></td> <td></td> </tr> <tr> <td>CNMG190608-DR</td> <td>0.8</td> <td>0.7-10.0</td> <td>0.2-0.5</td> <td></td> <td>●</td> <td>●</td> <td>●</td> <td>●</td> <td>●</td> <td>●</td> <td>●</td> <td>○</td> <td>●</td> <td>●</td> <td></td> <td></td> <td></td> <td></td> <td></td> <td></td> <td></td> <td></td> <td></td> <td></td> <td></td> <td></td> <td></td> <td></td> </tr> <tr> <td>CNMG190612-DR</td> <td>1.2</td> <td>1-10</td> <td>0.25-0.70</td> <td>○</td> <td>●</td> <td>●</td> <td>●</td> <td>●</td> <td>●</td> <td>●</td> <td>●</td> <td>○</td> <td>●</td> <td>●</td> <td></td> <td></td> <td></td> <td></td> <td></td> <td></td> <td></td> <td></td> <td></td> <td></td> <td></td> <td></td> <td></td> <td></td> </tr> <tr> <td>CNMG190616-DR</td> <td>1.6</td> <td>1.5-10.0</td> <td>0.3-0.8</td> <td></td> <td>●</td> <td>●</td> <td>●</td> <td>●</td> <td>●</td> <td>●</td> <td>●</td> <td>○</td> <td>●</td> <td>●</td> <td></td> <td></td> <td></td> <td></td> <td></td> <td></td> <td></td> <td></td> <td></td> <td></td> <td></td> <td></td> <td></td> <td></td> </tr> <tr> <td>CNMG190624-DR</td> <td>2.4</td> <td>2-10</td> <td>0.32-0.90</td> <td>○</td> <td></td> <td>●</td> <td>●</td> <td>●</td> <td>●</td> <td>●</td> <td>●</td> <td></td> <td>○</td> <td>●</td> <td></td> <td></td> <td></td> <td></td> <td></td> <td></td> <td></td> <td></td> <td></td> <td></td> <td></td> <td></td> <td></td> <td></td> </tr> <tr> <td>CNMG250924-DR</td> <td>2.4</td> <td>2-15</td> <td>0.4-1.0</td> <td></td> <td></td> <td>●</td> <td>●</td> <td>●</td> <td>●</td> <td>●</td> <td>●</td> <td></td> <td></td> <td></td> <td></td> <td></td> <td></td> <td></td> <td></td> <td></td> <td></td> <td></td> <td></td> <td></td> <td></td> <td></td> <td></td> <td></td> </tr> <tr> <td rowspan="4">SNR  Roughing</td> <td>CNMG120408-SNR</td> <td>0.8</td> <td>1-3</td> <td>0.1-0.4</td> <td></td> <td></td> <td></td> <td></td> <td></td> <td></td> <td></td> <td></td> <td></td> <td></td> <td></td> <td>●</td> <td></td> <td></td> <td></td> <td></td> <td>●</td> <td>●</td> <td></td> <td></td> <td></td> <td></td> <td></td> <td></td> </tr> <tr> <td>CNMG120412-SNR</td> <td>1.2</td> <td>1-3</td> <td>0.2-0.6</td> <td></td> <td></td> <td></td> <td></td> <td></td> <td></td> <td></td> <td></td> <td></td> <td></td> <td></td> <td>●</td> <td></td> <td></td> <td></td> <td></td> <td></td> <td>●</td> <td>●</td> <td></td> <td></td> <td></td> <td></td> <td></td> </tr> <tr> <td>CNMG160608-SNR</td> <td>0.8</td> <td>2-6</td> <td>0.1-0.4</td> <td></td> <td></td> <td></td> <td></td> <td></td> <td></td> <td></td> <td></td> <td></td> <td></td> <td></td> <td>●</td> <td></td> <td></td> <td></td> <td></td> <td></td> <td>●</td> <td>●</td> <td></td> <td></td> <td></td> <td>○</td> <td></td> </tr> <tr> <td>CNMG190616-SNR</td> <td>1.6</td> <td>2-7</td> <td>0.2-0.6</td> <td></td> <td></td> <td></td> <td></td> <td></td> <td></td> <td></td> <td></td> <td></td> <td></td> <td></td> <td>○</td> <td></td> <td></td> <td></td> <td></td> <td></td> <td></td> <td>●</td> <td></td> <td></td> <td></td> <td>○</td> <td></td> </tr> </tbody> </table>																ISO	r	a <sub>p</sub>	f	YBC103	YB6315	YBC152	YBC203	YBC252	YBC352	YBM153	YBM253	YBD102	YB7315	YBD152	YBD152C	YBG101	YBG102	YBG105	YBG205	YB9320	YPD201	YBS103	YNG151	YNT251	YNG151C	YD101	YD201	DR  Roughing	CNMG120408-DR	0.8	0.7-7.0	0.2-0.5	○	●	●	●	●	●	●	●	●	●	●														CNMG120412-DR	1.2	1-7	0.25-0.70	○	●	●	●	●	●	●	●	●	●	●														CNMG120416-DR	1.6	1.5-7.0	0.32-0.75		○	●	●	●	●	●	●	○	●	●															CNMG160608-DR	0.8	0.7-8.0	0.2-0.5			●	●	●	●	●	●	○	●	●															CNMG160612-DR	1.2	1-8	0.25-0.70	○	●	●	●	●	●	●	●	●	●	●															CNMG160616-DR	1.6	1.5-8.0	0.3-0.8	○	●	●	●	●	●	●	●	○	●	●															CNMG190608-DR	0.8	0.7-10.0	0.2-0.5		●	●	●	●	●	●	●	○	●	●															CNMG190612-DR	1.2	1-10	0.25-0.70	○	●	●	●	●	●	●	●	○	●	●															CNMG190616-DR	1.6	1.5-10.0	0.3-0.8		●	●	●	●	●	●	●	○	●	●															CNMG190624-DR	2.4	2-10	0.32-0.90	○		●	●	●	●	●	●		○	●															CNMG250924-DR	2.4	2-15	0.4-1.0			●	●	●	●	●	●																		SNR  Roughing	CNMG120408-SNR	0.8	1-3	0.1-0.4												●					●	●							CNMG120412-SNR	1.2	1-3	0.2-0.6												●						●	●						CNMG160608-SNR	0.8	2-6	0.1-0.4												●						●	●				○		CNMG190616-SNR	1.6	2-7	0.2-0.6												○							●				○	
ISO	r	a <sub>p</sub>	f	YBC103	YB6315	YBC152	YBC203	YBC252	YBC352	YBM153	YBM253	YBD102	YB7315	YBD152	YBD152C	YBG101	YBG102	YBG105	YBG205	YB9320	YPD201	YBS103	YNG151	YNT251	YNG151C	YD101	YD201																																																																																																																																																																																																																																																																																																																																																																																																																																																																			
DR  Roughing	CNMG120408-DR	0.8	0.7-7.0	0.2-0.5	○	●	●	●	●	●	●	●	●	●	●																																																																																																																																																																																																																																																																																																																																																																																																																																																																															
	CNMG120412-DR	1.2	1-7	0.25-0.70	○	●	●	●	●	●	●	●	●	●	●																																																																																																																																																																																																																																																																																																																																																																																																																																																																															
	CNMG120416-DR	1.6	1.5-7.0	0.32-0.75		○	●	●	●	●	●	●	○	●	●																																																																																																																																																																																																																																																																																																																																																																																																																																																																															
	CNMG160608-DR	0.8	0.7-8.0	0.2-0.5			●	●	●	●	●	●	○	●	●																																																																																																																																																																																																																																																																																																																																																																																																																																																																															
	CNMG160612-DR	1.2	1-8	0.25-0.70	○	●	●	●	●	●	●	●	●	●	●																																																																																																																																																																																																																																																																																																																																																																																																																																																																															
	CNMG160616-DR	1.6	1.5-8.0	0.3-0.8	○	●	●	●	●	●	●	●	○	●	●																																																																																																																																																																																																																																																																																																																																																																																																																																																																															
	CNMG190608-DR	0.8	0.7-10.0	0.2-0.5		●	●	●	●	●	●	●	○	●	●																																																																																																																																																																																																																																																																																																																																																																																																																																																																															
	CNMG190612-DR	1.2	1-10	0.25-0.70	○	●	●	●	●	●	●	●	○	●	●																																																																																																																																																																																																																																																																																																																																																																																																																																																																															
	CNMG190616-DR	1.6	1.5-10.0	0.3-0.8		●	●	●	●	●	●	●	○	●	●																																																																																																																																																																																																																																																																																																																																																																																																																																																																															
	CNMG190624-DR	2.4	2-10	0.32-0.90	○		●	●	●	●	●	●		○	●																																																																																																																																																																																																																																																																																																																																																																																																																																																																															
CNMG250924-DR	2.4	2-15	0.4-1.0			●	●	●	●	●	●																																																																																																																																																																																																																																																																																																																																																																																																																																																																																			
SNR  Roughing	CNMG120408-SNR	0.8	1-3	0.1-0.4												●					●	●																																																																																																																																																																																																																																																																																																																																																																																																																																																																								
	CNMG120412-SNR	1.2	1-3	0.2-0.6												●						●	●																																																																																																																																																																																																																																																																																																																																																																																																																																																																							
	CNMG160608-SNR	0.8	2-6	0.1-0.4												●						●	●				○																																																																																																																																																																																																																																																																																																																																																																																																																																																																			
	CNMG190616-SNR	1.6	2-7	0.2-0.6												○							●				○																																																																																																																																																																																																																																																																																																																																																																																																																																																																			

● Ex stock ○ On demand  
YBC152F, YBC252F, YBM153F, YBM253F available

HC<sup>1</sup> Coated carbide  
HT Uncoated cermet  
HC<sup>2</sup> Coated cermet  
HW Uncoated carbide

Tool holder					
DCLNR/L	PCBNR/L	PCLNR/L	MCBNR/L	MCLNR/L	S***-PCLNR/L
Kr: 95°	Kr: 75°	Kr: 95°	Kr: 75°	Kr: 95°	Kr: 95°
A230	A237	A238	A252	A253	A324

**A**

Turning

**B**

Milling

**C**

Drilling

**D**

Technical Information

**E**

Index

CN**	L	I.C	S	d
12 04	12.9	12.7	4.76	5.16
16 06	16.1	15.875	6.35	6.35
19 06	19.3	19.05	6.35	7.94
25 07	25.79	25.4	7.94	9.12
25 09	25.79	25.4	9.525	9.12

- Ideal machining conditions
- ⊗ Normal machining conditions
- ⊗ Unfavourable machining conditions

### Turning inserts

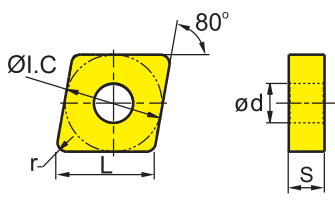

CN** negative insert				HC <sup>1</sup> (CVD)										HC <sup>1</sup> (PVD)			HT	HC <sup>2</sup>	HW												
				P																											
				M																											
				K																											
				N																											
				S																											
				H																											
ISO		r	a <sub>p</sub>	f	YBC103	YB6315	YBC152	YBC203	YBC252	YBC352	YBM153	YBM253	YBD102	YB7315	YBD152	YBD152C	YBG101	YBG102	YBG105	YBG205	YB9320	YPD201	YBS103	YNG151	YNT251	YNG151C	YD101	YD201			
DR	CNMM120412-DR	1.2	1.0-7.5	0.25-0.70	○	●	●	●	○	○																					
	CNMM160612-DR	1.2	1.0-9.5	0.25-0.70		●	●																								
Roughing	CNMM160616-DR	1.6	1.5-9.5	0.32-0.90		●	●	○																							
	CNMM190612-DR	1.2	1-12	0.25-0.70	○	●	●	●	●	●																					
	CNMM190616-DR	1.6	1.5-12.0	0.32-0.90		●	●	●																							
	CNMM190624-DR	2.4	2-12	0.35-1.20	○	●	●																								
Roughing	CNMM250924-DR	2.4	2.0-12.5	0.2-1.2		●	●	○																							
	CNMG120408-ER	0.8	2.0-7.6	0.15-0.55									○																		
	CNMG120412-ER	1.2	2.0-7.6	0.25-0.80									○																		
	CNMG160612-ER	1.2	2-10	0.35-0.80									○																		
	CNMG160616-ER	1.6	2-10	0.45-1.00									○																		
Roughing	CNMG190612-ER	1.2	2.0-11.4	0.35-1.00				○				○								○											
	CNMG190616-ER	1.6	2.0-11.4	0.45-1.10								○																			
	CNMM250724-ER	2.4	2.0-12.5	0.3-1.4						●																					
	CNMM250732-ER	3.2	2.0-12.5	0.45-1.80						○																					
Roughing	CNMM250924-ER	2.4	2.0-12.5	0.3-1.4						●		○																			
	CNMM250932-ER	3.2	2.0-12.5	0.45-1.80						●																					

● Ex stock   ○ On demand  
 YBC152F, YBC252F, YBM153F, YBM253F available

HC<sup>1</sup> Coated carbide  
 HT Uncoated cermet  
 HC<sup>2</sup> Coated cermet  
 HW Uncoated carbide

Tool holder					
DCLNR/L	PCBNR/L	PCLNR/L	MCBNR/L	MCLNR/L	S***-PCLNR/L
Kr: 95°	Kr: 75°	Kr: 95°	Kr: 75°	Kr: 95°	Kr: 95°
A230	A237	A238	A252	A253	A324



CNMM	L	I.C	S	d
12 04	12.9	12.7	4.76	5.16
16 06	16.1	15.875	6.35	6.35
19 06	19.3	19.05	6.35	7.94
25 09	25.79	25.4	9.525	9.12

- Ideal machining conditions
- Normal machining conditions
- Unfavourable machining conditions

**Turning inserts**

CN** negative insert				HC <sup>1</sup> (CVD)								HC <sup>1</sup> (PVD)		HT	HC <sup>2</sup>	HW												
ISO	r	a <sub>p</sub>	f	YBC103	YB6315	YBC152	YBC203	YBC252	YBC352	YBM153	YBM253	YBD102	YB7315	YBD152	YBD152C	YBG101	YBG102	YBG105	YBG205	YB9320	YPD201	YBS103	YNG151	YNT251	YNG151C	YD101	YD201	
				LR	<b>CNMM120408-LR</b>	0.8	1-5	0.1-0.5	●	●																		
	<b>CNMM120412-LR</b>	1.2	2-6	0.2-0.7	●	●				○																		
	<b>CNMM120416-LR</b>	1.6	2.0-6.5	0.25-0.80		●																						
	<b>CNMM160608-LR</b>	0.8	1-7	0.2-0.6	●	●				○																		
	<b>CNMM160612-LR</b>	1.2	1.0-7.5	0.2-0.7	●	●				●																		
	<b>CNMM160616-LR</b>	1.6	1.0-8.5	0.25-0.80	○	●	○	●																				
	<b>CNMM190612-LR</b>	1.2	2.0-10.5	0.2-0.7	●	●																						
	<b>CNMM190616-LR</b>	1.6	2.0-10.5	0.3-1.0	●	●				●																		
	<b>CNMM190624-LR</b>	2.4	2.0-10.5	0.3-1.1	●	○																						
	<b>CNMM250924-LR</b>	2.4	2.0-12.5	0.3-1.2	○	●																						

● Ex stock ○ On demand  
 YBC152F, YBC252F, YBM153F, YBM253F available

HC<sup>1</sup> Coated carbide  
 HT Uncoated cermet  
 HC<sup>2</sup> Coated cermet  
 HW Uncoated carbide

Tool holder					
DCLNR/L	PCBNR/L	PCLNR/L	MCBNR/L	MCLNR/L	S***-PCLNR/L
Kr: 95°	Kr: 75°	Kr: 95°	Kr: 75°	Kr: 95°	Kr: 95°
A230	A237	A238	A252	A253	A324

**A**

Turning

**B**

Milling

**C**

Drilling

**D**

Technical Information

**E**

Index

CNMM	L	I.C	S	d
12 04	12.9	12.7	4.76	5.16
16 06	16.1	15.875	6.35	6.35
19 06	19.3	19.05	6.35	7.94
25 09	25.79	25.4	9.525	9.12

- Ideal machining conditions
- ⊗ Normal machining conditions
- ⊗ Unfavourable machining conditions

## Turning inserts

CN** negative insert					HC <sup>1</sup> (CVD)										HC <sup>1</sup> (PVD)		HT	HC <sup>2</sup>	HW												
					P	M	K	N	S	H																					
ISO					r	a <sub>p</sub>	f	YBC103	YB6315	YBC152	YBC203	YBC252	YBC352	YBM153	YBM253	YBD102	YB7315	YBD152	YBD152C	YBG101	YBG102	YBG105	YBG205	YB9320	YPD201	YBS103	YNG151	YNT251	YNG151C	YD101	YD201
Basic	<b>CNMM120404</b>				0.4	0.5-7.0	0.1-0.5																								
	<b>CNMM190612</b>				1.2	0.5-10.5	0.1-0.8																								
	<b>CNMM190616</b>				1.6	0.5-10.5	0.1-1.0																								
Medium Cut																															
HDR	<b>CNMM120408-HDR</b>				0.8	1-7	0.2-0.6							●	●																
	<b>CNMM120412-HDR</b>				1.2	1-7	0.3-0.8							○	●																
	<b>CNMM120416-HDR</b>				1.6	1-7	0.4-1.0							●	●																
	<b>CNMM160612-HDR</b>				1.2	1.5-7.5	0.3-0.8							●	●																
	<b>CNMM160616-HDR</b>				1.6	1.5-8.5	0.4-1.0							○	●																
	<b>CNMM160624-HDR</b>				2.4	1.5-10.5	0.8-1.2							○	○																
	<b>CNMM190608-HDR</b>				0.8	2.0-12.5	0.3-0.7								○																
	<b>CNMM190612-HDR</b>				1.2	2.0-12.5	0.35-0.80								○	●															
	<b>CNMM190616-HDR</b>				1.6	2.0-12.5	0.5-1.1								○	●	●			○											
	<b>CNMM190624-HDR</b>				2.4	2.0-12.5	0.8-1.2								●	●															
HPR	<b>CNMM250924-HDR</b>				2.4	2.0-12.5	0.8-1.4							○	●																
	<b>CNMM190616-HPR</b>				1.6	2.0-10.5	0.5-1.0								○																
	<b>CNMM190624-HPR</b>				2.4	2.0-10.5	0.7-1.4							●	○																
<b>CNMM250924-HPR</b>				2.4	2.0-12.5	0.7-1.4								●	●																

● Ex stock    ○ On demand  
 YBC152F, YBC252F, YBM153F, YBM253F available

HC<sup>1</sup> Coated carbide  
 HT Uncoated cermet  
 HC<sup>2</sup> Coated cermet  
 HW Uncoated carbide

Tool holder					
DCLNR/L	PCBNR/L	PCLNR/L	MCBNR/L	MCLNR/L	S***-PCLNR/L
Kr: 95°					
A230	A237	A238	A252	A253	A324

System code > A48    Grade selection > A42    Technical info > A501    Cutting data > A366



CN**	L	I.C	S	d
12 04	12.9	12.7	4.76	5.16
16 06	16.1	15.875	6.35	6.35
19 06	19.3	19.05	6.35	7.94

- Ideal machining conditions
- Normal machining conditions
- Unfavourable machining conditions

**Turning inserts**

CN** negative insert				HC <sup>1</sup> (CVD)								HC <sup>1</sup> (PVD)			HT	HC <sup>2</sup>	HW											
				P	M	K	N	S	H																			
ISO	r	a <sub>p</sub>	f	YBC103	YB6315	YBC152	YBC203	YBC252	YBC352	YBM153	YBM253	YBD102	YB7315	YBD152	YBD152C	YBG101	YBG102	YBG105	YBG205	YB9320	YPD201	YBS103	YNG151	YNT251	YNG151C	YD101	YD201	
<b>Flat</b> 	CNMA120404	0.4	0.2-5.0	0.05-0.40								○																
	CNMA120408	0.8	0.2-5.0	0.05-0.50								●	●	●	●													
	CNMA120412	1.2	0.2-5.0	0.1-0.6								●	●	●	●												○	
	CNMA120416	1.6	0.2-5.0	0.10-0.65								●	●	○														
	CNMA160608	0.8	0.2-7.0	0.1-0.5								○																
	CNMA160612	1.2	0.2-7.0	0.1-0.6								●	●															
	CNMA160616	1.6	0.2-7.0	0.15-0.65								○	●															
	CNMA190612	1.2	0.2-8.0	0.15-0.70								○	●															
CNMA190616	1.6	0.2-8.0	0.15-0.70								●	●																
<b>Basic</b> 	CNMG120404	0.4	0.1-5.0	0.05-0.50				○																				
	CNMG120408	0.8	0.1-5.0	0.1-0.6				○						○														
	CNMG120412	1.2	0.1-5.0	0.1-0.7		○	○																					
	CNMG160612	1.2	0.1-7.0	0.1-0.7																								
	CNMG190608	0.8	0.1-8.0	0.1-0.7																								
	CNMG190612	1.2	0.1-8.0	0.1-0.8																								
CNMG190616	1.6	0.1-8.0	0.1-1.0																									

● Ex stock ○ On demand  
 YBC152F, YBC252F, YBM153F, YBM253F available

HC<sup>1</sup> Coated carbide  
 HT Uncoated cermet  
 HC<sup>2</sup> Coated cermet  
 HW Uncoated carbide

Tool holder					
DCLNR/L	PCBNR/L	PCLNR/L	MCBNR/L	MCLNR/L	S***-PCLNR/L
Kr: 95°	Kr: 75°	Kr: 95°	Kr: 75°	Kr: 95°	Kr: 95°
A230	A237	A238	A252	A253	A324

**A**

Turning

**B**

Milling

**C**

Drilling

**D**

Technical Information

**E**

Index

- Ideal machining conditions
- ● Normal machining conditions
- ● ● Unfavourable machining conditions

DN**	L	I.C	S	d
11 04	11.6	9.525	4.76	3.81
15 04	15.5	12.7	4.76	5.16
15 06	15.5	12.7	6.35	5.16

## Turning inserts

DN** negative insert	HC <sup>1</sup> (CVD)							HC <sup>1</sup> (PVD)			HT	HC <sup>2</sup>	HW
	P	M	K	N	S	H							
	●●●●●●●●	●●●●●●●●	●●●●●●●●	●●●●●●●●	●●●●●●●●	●●●●●●●●	●●●●●●●●	●●●●●●●●	●●●●●●●●	●●●●●●●●	●●●●●●●●	●●●●●●●●	

	ISO	r	a <sub>p</sub>	f	YBC103	YB6315	YBC152	YBC203	YBC252	YBC352	YBM153	YBM253	YBD102	YB7315	YBD152	YBD152C	YBG101	YBG102	YBG105	YBG205	YB9320	YPD201	YBS103	YNG151	YNT251	YNG151C	YD101	YD201	
					WG	<b>DNMX110404-WG</b>	0.4	0.2-1.5	0.08-0.30		○																		
	<b>DNMX110408-WG</b>	0.8	0.5-3.5	0.15-0.50		●	●																						
	<b>DNMX150408-WG</b>	0.8	0.5-5.0	0.15-0.70		○																							
	<b>DNMX150608-WG</b>	0.8	0.5-5.0	0.15-0.70		○	○																						
Wiper	<b>DNMX150612-WG</b>	1.2	0.8-6.0	0.20-0.75		○																							
ADF	<b>DNMG150604-ADF</b>	0.4	0.5-6.0	0.15-0.50	○															●				○					
	<b>DNMG150608-ADF</b>	0.8	0.1-4.0	0.08-0.50	○															●	●			○					
	<b>DNMG150612-ADF</b>	1.2	0.5-4.0	0.15-0.50	○																								
Finishing																													
	<b>DNMG110404-DF</b>	0.4	0.15-2.00	0.08-0.25		●	●																						
	<b>DNMG110408-DF</b>	0.8	0.15-2.00	0.1-0.3		●	●																						
DF	<b>DNMG110412-DF</b>	1.2	0.35-1.50	0.15-0.50		○																							
	<b>DNMG150404-DF</b>	0.4	0.15-2.00	0.08-0.25		●	●																						
	<b>DNMG150408-DF</b>	0.8	0.15-2.00	0.1-0.3		●	●																						
	<b>DNMG150412-DF</b>	1.2	0.35-1.50	0.15-0.50		○																							
Finishing	<b>DNMG150604-DF</b>	0.4	0.8-6.0	0.18-0.60		●	●																						
	<b>DNMG150608-DF</b>	0.8	0.15-2.00	0.1-0.3		●	●																						
	<b>DNMG150612-DF</b>	1.2	0.2-2.5	0.10-0.35		●																							
SF	<b>DNMG110404-SF</b>	0.4	0.05-0.50	0.05-0.25																						●			
	<b>DNMG150404-SF</b>	0.4	0.05-0.50	0.05-0.25																						●			
	<b>DNMG150408-SF</b>	0.8	0.05-0.50	0.10-0.35																						●			
	<b>DNMG150604-SF</b>	0.4	0.05-0.50	0.05-0.25																						●			
Finishing	<b>DNMG150608-SF</b>	0.8	0.05-0.50	0.10-0.35																						●			

● Ex stock   ○ On demand  
 YBC152F, YBC252F, YBM153F, YBM253F available

HC<sup>1</sup> Coated carbide  
 HT Uncoated cermet  
 HC<sup>2</sup> Coated cermet  
 HW Uncoated carbide

Tool holder						
DDJNR/L	PDJNR/L	PDNNR/L	MDJNR/L	MDPNN	S***-PDSNR/L	A***-PDUNR/L
Kr: 93°	Kr: 93°	Kr: 63°	Kr: 93°	Kr: 62°30'	Kr: 62°30'	Kr: 93°
A231	A240	A241	A254	A255	A326	A327

System code > A48   Grade selection > A42   Technical info > A501   Cutting data > A366



- Ideal machining conditions
- Normal machining conditions
- Unfavourable machining conditions

DNMG	L	I.C	S	d
11 04	11.6	9.525	4.76	3.81
15 06	15.5	12.7	6.35	5.16

**Turning inserts**

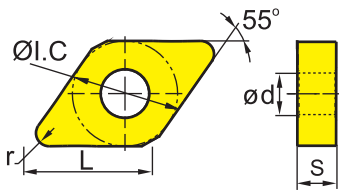

DN** negative insert				HC <sup>1</sup> (CVD)								HC <sup>1</sup> (PVD)			HT	HC <sup>2</sup>	HW			
				P	M	K	N	S	H											
ISO				r	a <sub>p</sub>	f														
XF 	DNMG110404-XF	0.4	0.5-2.0	0.1-0.25	●															
	DNMG110408-XF	0.8	0.5-2.0	0.1-0.30	○															
	DNMG150604-XF	0.4	0.5-2.5	0.1-0.25	●	●														
	DNMG150608-XF	0.8	0.5-2.5	0.1-0.30	●	●														
	DNMG150612-XF	1.2	0.5-2.5	0.1-0.35	●	●														
XM 	DNMG110404-XM	0.4	1-3.85	0.2-0.4	●	○														
	DNMG110408-XM	0.8	1-3.85	0.2-0.4	●	○														
	DNMG110412-XM	1.2	1-3.85	0.2-0.6	●	○														
	DNMG150604-XM	0.4	1-5.25	0.2-0.4	●	●														
	DNMG150608-XM	0.8	1-5.25	0.2-0.4	●	●														
	DNMG150612-XM	1.2	1-5.25	0.2-0.6	●	●														
DNMG150616-XM	1.6	1-5.25	0.2-0.65	●	●															

● Ex stock ○ On demand

HC<sup>1</sup> Coated carbide  
 HT Uncoated cermet  
 HC<sup>2</sup> Coated cermet  
 HW Uncoated carbide

**Tool holder**

DDJNR/L	PDJNR/L	PDNNR/L	MDJNR/L	MDPNN	S***-PDSNR/L	A***-PDUNR/L
Kr: 93°	Kr: 93°	Kr: 63°	Kr: 93°	Kr: 62°30'	Kr: 62°30'	Kr: 93°
A231	A240	A241	A254	A255	A326	A327

System code > A48

Grade selection > A42

Technical info > A501

Cutting data > A366



**A** Turning  
**B** Milling  
**C** Drilling  
**D** Technical Information  
**E** Index



**A**

Turning

**B**

Milling

**C**

Drilling

**D**

Technical Information

**E**

Index

- Ideal machining conditions
- ⊗ Normal machining conditions
- ⊗ Unfavourable machining conditions

DNMG	L	I.C	S	d
11 04	11.6	9.525	4.76	3.81
15 04	15.5	12.7	4.76	5.16
15 06	15.5	12.7	6.35	5.16

## Turning inserts

DN** negative insert	HC <sup>1</sup> (CVD)					HC <sup>1</sup> (PVD)		HT	HC <sup>2</sup>	HW
	P	M	K	N	S	H				
	●●●●●	●●●●●	●●●●●	●●●●●	●●●●●	●●●●●	●●●●●	●●●●●	●●●●●	●●●●●
	●●●●●	●●●●●	●●●●●	●●●●●	●●●●●	●●●●●	●●●●●	●●●●●	●●●●●	●●●●●

ISO	r	a <sub>p</sub>	f	YBC103	YBC152	YBC203	YBC252	YBC352	YBM153	YBM253	YBD102	YBD152	YBD152C	YBG101	YBG102	YBG105	YBG205	YB9320	YPD201	YBS103	YNG151	YNT251	YNG151C	YD101	YD201
				DM	DM	DM	DM	DM	DM	DM	DM	DM	DM	DM	DM	DM	DM	DM	DM	DM	DM	DM	DM	DM	DM
DNMG110404-DM	0.4	0.4-5.0	0.1-0.3	●	●																				
DNMG110408-DM	0.8	0.5-5.0	0.15-0.50	●	●																				
DNMG110412-DM	1.2	0.8-5.0	0.18-0.50	●	●																				
DNMG150404-DM	0.4	0.4-6.0	0.1-0.3	●	●																				
DNMG150408-DM	0.8	0.5-6.0	0.15-0.50	●	●																				
DNMG150412-DM	1.2	0.8-6.0	0.18-0.60	○	●																				
DNMG150604-DM	0.4	1-6	0.23-0.65	●	●																				
DNMG150608-DM	0.8	0.5-6.0	0.15-0.50	○	●					●															
DNMG150612-DM	1.2	0.8-6.0	0.18-0.60	○	●																				
DNMG150616-DM	1.6	1-6	0.23-0.65	○	●																				
DNMG110404-PM	0.4	0.4-5.0	0.1-0.3					●			○														
DNMG110408-PM	0.8	0.5-5.0	0.15-0.50		○			●			●														
DNMG110412-PM	1.2	0.8-5.0	0.18-0.50					○			●														
DNMG150404-PM	0.4	0.4-6.0	0.1-0.3		○																				
DNMG150408-PM	0.8	0.5-6.0	0.15-0.50		●			●			●	●													
DNMG150412-PM	1.2	0.8-6.0	0.18-0.60					○																	
DNMG150416-PM	1.6	1-6	0.23-0.65					○																	
DNMG150604-PM	0.4	0.4-6.0	0.1-0.3		●			●			●	○													
DNMG150608-PM	0.8	0.5-6.0	0.15-0.50		●			●			●	●													
DNMG150612-PM	1.2	0.8-6.0	0.18-0.60		●			●			●	●													
DNMG150616-PM	1.6	1-6	0.23-0.65					●																	

● Ex stock    ○ On demand  
 YBC152F, YBC252F, YBM153F, YBM253F available

HC<sup>1</sup> Coated carbide  
 HT Uncoated cermet  
 HC<sup>2</sup> Coated cermet  
 HW Uncoated carbide

Tool holder						
DDJNR/L	PDJNR/L	PDNRR/L	MDJNR/L	MDPNN	S***-PDSNR/L	A***-PDUNR/L
Kr: 93°	Kr: 93°	Kr: 63°	Kr: 93°	Kr: 62°30'	Kr: 62°30'	Kr: 93°
A231	A240	A241	A254	A255	A326	A327



- Ideal machining conditions
- ⊗ Normal machining conditions
- ⊗ Unfavourable machining conditions

DNMG	L	I.C	S	d
15 06	15.5	12.7	6.35	5.16

**Turning inserts**

DN** negative insert				HC <sup>1</sup> (CVD)								HC <sup>1</sup> (PVD)			HT	HC <sup>2</sup>	HW											
	<b>P</b>	●●●●●●●●	●●●●●●●●										●●	●●														
	<b>M</b>			●●	⊗					●●	●●	●●	●●	●●	●●													
	<b>K</b>																											
	<b>N</b>									●●	●●					●●	⊗											
	<b>S</b>															●●	⊗											
	<b>H</b>																											
ISO	r	a <sub>p</sub>	f	YBC103	YB6315	YBC152	YBC203	YBC252	YBC352	YBM153	YBM253	YBD102	YB7315	YBD152	YBD152C	YBG101	YBG102	YBG105	YBG205	YB9320	YPD201	YBS103	YNG151	YNT251	YNG151C	YD101	YD201	
ZM	<b>DNMG150612-ZM</b>	1.2	1.0-5.5	0.15-0.60	○	●																						
Medium Cut																												

● Ex stock ○ On demand  
 YBC152F, YBC252F, YBM153F, YBM253F available

HC<sup>1</sup> Coated carbide  
 HT Uncoated cermet  
 HC<sup>2</sup> Coated cermet  
 HW Uncoated carbide

Tool holder						
DDJNR/L	PDJNR/L	PDNNR/L	MDJNR/L	MDPNN	S***-PDSNR/L	S***-PDUNR/L
Kr: 93°	Kr: 93°	Kr: 63°	Kr: 93°	Kr: 62°30'	Kr: 62°30'	Kr: 93°
A231	A240	A241	A254	A255	A326	A327

**A**

Turning

**B**

Milling

**C**

Drilling

**D**

Technical Information

**E**

Index

- Ideal machining conditions
- ● Normal machining conditions
- ● Unfavourable machining conditions

DN**	L	I.C	S	d
11 04	11.6	9.525	4.76	3.81
15 04	15.5	12.7	4.76	5.16
15 06	15.5	12.7	6.35	5.16

## Turning inserts

DN** negative insert				HC <sup>1</sup> (CVD)								HC <sup>1</sup> (PVD)		HT	HC <sup>2</sup>	HW														
	P	M	K	N	S	H																								
	ISO	r	a <sub>p</sub>	f	YBC103	YB6315	YBC152	YBC203	YBC252	YBC352	YBM153	YBM253	YBD102	YB7315	YBD152	YBD152C	YBG101	YBG102	YBG105	YBG205	YB9320	YPD201	YBS103	YNG151	YNT251	YNG151C	YD101	YD201		
		<b>DNMG110404-EF</b>	0.4	0.1-1.5	0.05-0.20							○								●										
		<b>DNMG110408-EF</b>	0.8	0.1-1.5	0.1-0.4							○								●										
		<b>DNMG150404-EF</b>	0.4	0.1-1.5	0.05-0.30																●									
		<b>DNMG150408-EF</b>	0.8	0.1-1.5	0.1-0.4																●									
<b>DNMG150604-EF</b>		0.4	0.1-1.5	0.05-0.30							●									●										
<b>DNMG150608-EF</b>		0.8	0.1-1.5	0.1-0.4							●									●										
<b>DNMG150612-EF</b>		1.2	0.1-1.5	0.15-0.50																●										
	<b>DNMG150604L-FM</b>	0.4	0.5-3.0	0.05-0.30						●									●											
	<b>DNMG150604R-FM</b>	0.4	0.5-3.0	0.05-0.30			●		●										●											
	<b>DNMG150608L-FM</b>	0.8	0.5-3.0	0.1-0.5			○		●										●											
	<b>DNMG150608R-FM</b>	0.8	0.5-3.0	0.1-0.5			●		●										●											
	<b>DNEG150404-NF</b>	0.4	0.2-3.0	0.05-0.30															○											
	<b>DNEG150408-NF</b>	0.8	0.2-3.0	0.1-0.4															○											
	<b>DNEG150604-NF</b>	0.4	0.2-3.0	0.05-0.30															○	●							○			
	<b>DNEG150608-NF</b>	0.8	0.2-3.0	0.1-0.4															○	●							○			
	<b>DNEG150608-NGF</b>	0.8	0.2-3.0	0.05-0.40																●										
<b>DNEG150612-NGF</b>	1.2	0.2-3.0	0.1-0.5																●											

● Ex stock   ○ On demand  
 YBC152F, YBC252F, YBM153F, YBM253F available

HC<sup>1</sup> Coated carbide  
 HT Uncoated cermet  
 HC<sup>2</sup> Coated cermet  
 HW Uncoated carbide

Tool holder						
DDJNR/L	PDJNR/L	PDNNR/L	MDJNR/L	MDPNN	S***-PDSNR/L	A***-PDUNR/L
Kr: 93°	Kr: 93°	Kr: 63°	Kr: 93°	Kr: 62°30'	Kr: 62°30'	Kr: 93°
A231	A240	A241	A254	A255	A326	A327



DNMG	L	I.C	S	d
11 04	11.6	9.525	4.76	3.81
15 04	15.5	12.7	4.76	5.16
15 06	15.5	12.7	6.35	5.16

- Ideal machining conditions
- ⊗ Normal machining conditions
- ⊗ Unfavourable machining conditions

**Turning inserts**

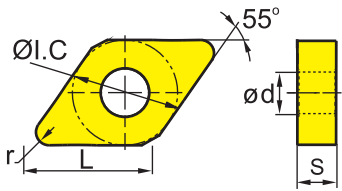

DN** negative insert				HC <sup>1</sup> (CVD)								HC <sup>1</sup> (PVD)			HT	HC <sup>2</sup>	HW									
				P	M	K	N	S	H																	
ISO	r	a <sub>p</sub>	f	YBC103	YB6315	YBC152	YBC203	YBC252	YBC352	YBM153	YBM253	YBD102	YBD152	YBD152C	YBG101	YBG102	YBG105	YBG205	YB9320	YPD201	YBS103	YNG151	YNT251	YNG151C	YD101	YD201
EG 	<b>DNMG150604-EG</b>	0.4	1-3	0.05-0.30						●																
	<b>DNMG150608-EG</b>	0.8	1-3	0.1-0.4						●	○							●	●							
	<b>DNMG150612-EG</b>	1.2	1-3	0.2-0.6						●	●							●	●							
Medium Cut																										
EM 	<b>DNMG110404-EM</b>	0.4	0.5-4.4	0.05-0.30						●								●								
	<b>DNMG110408-EM</b>	0.8	0.5-4.4	0.10-0.45						●								●								
	<b>DNMG150404-EM</b>	0.4	0.5-6.4	0.05-0.30						○								○								
	<b>DNMG150408-EM</b>	0.8	0.5-6.4	0.10-0.45						○								●								
	<b>DNMG150412-EM</b>	1.2	0.5-6.4	0.1-0.6						○								●								
	<b>DNMG150604-EM</b>	0.4	0.2-6.4	0.05-0.30						●	●							●								
	<b>DNMG150608-EM</b>	0.8	0.5-6.4	0.10-0.45						●	●							●								
<b>DNMG150612-EM</b>	1.2	0.5-6.4	0.1-0.6						●	●							●									
Medium Cut																										
NM 	<b>DNMG150412-NM</b>	1.2	0.2-4.0	0.2-0.6													○									
	<b>DNMG150608-NM</b>	0.8	0.2-4.0	0.1-0.4													●									
	<b>DNMG150612-NM</b>	1.2	0.2-4.0	0.2-0.6													○	●								
Medium Cut																										
TC 	<b>DNMG150608-TC</b>	0.8	0.5-5.0	0.15-0.40								●		●												
	<b>DNMG150612-TC</b>	1.2	0.5-5.0	0.2-0.6								●		○												
Medium Cut																										

● Ex stock ○ On demand  
YBC152F, YBC252F, YBM153F, YBM253F available

HC<sup>1</sup> Coated carbide  
HT Uncoated cermet  
HC<sup>2</sup> Coated cermet  
HW Uncoated carbide

Tool holder						
DDJNR/L	PDJNR/L	PDNNR/L	MDJNR/L	MDPNN	S***-PDSNR/L	A***-PDUNR/L
Kr: 93°	Kr: 93°	Kr: 63°	Kr: 93°	Kr: 62°30'	Kr: 62°30'	Kr: 93°
A231	A240	A241	A254	A255	A326	A327

# General turning Negative inserts

**A**

Turning

- Ideal machining conditions
- ⊗ Normal machining conditions
- ⊗ Unfavourable machining conditions

DNMG	L	I.C	S	d
15 06	15.5	12.7	6.35	5.16

## Turning inserts

DN** negative insert				HC <sup>1</sup> (CVD)								HC <sup>1</sup> (PVD)		HT	HC <sup>2</sup>	HW												
				P	●	●	●	⊗	⊗	⊗				●	⊗	●												
				M					●	⊗		●	●	⊗	⊗	●												
				K								●	⊗															
				N										●	●				●	⊗								
				S											●	●	⊗	⊗		●	⊗							
				H																								
ISO	r	a <sub>p</sub>	f	YBC103	YB6315	YBC152	YBC203	YBC252	YBC352	YBM153	YBM253	YBD102	YB7315	YBD152	YBD152C	YBG101	YBG102	YBG105	YBG205	YB9320	YPD201	YBS103	YNG151	YNT251	YNG151C	YD101	YD201	
TK  Medium Cut	<b>DNMG150608-TK</b>	0.8	0.2-0.4	0.2-0.4																								
	<b>DNMG150612-TK</b>	1.2	0.2-0.4	0.2-0.45									○															
DR  Roughing	<b>DNMG150608-DR</b>	0.8	1-6	0.2-0.5		●	●					●	●															
	<b>DNMG150612-DR</b>	1.2	1-6	0.25-0.70		●	●					●	●															
	<b>DNMG150616-DR</b>	1.6	1-6	0.32-0.75		●						●	○															
SNR  Roughing	<b>DNMG150608-SNR</b>	0.8	0.2-6.0	0.1-0.5													●		○	●								
	<b>DNMG150612-SNR</b>	1.2	0.2-6.0	0.2-0.6													○		○	●								

● Ex stock   ○ On demand  
 YBC152F, YBC252F, YBM153F, YBM253F available

HC<sup>1</sup> Coated carbide  
 HT Uncoated cermet  
 HC<sup>2</sup> Coated cermet  
 HW Uncoated carbide

**B**

Milling

**C**

Drilling

**D**

Technical Information

**E**

Index

Tool holder						
DDJNR/L	PDJNR/L	PDNNR/L	MDJNR/L	MDPNN	S***-PDSNR/L	S***-PDUNR/L
Kr: 93°	Kr: 93°	Kr: 63°	Kr: 93°	Kr: 62°30'	Kr: 62°30'	Kr: 93°
A231	A240	A241	A254	A255	A326	A327



- Ideal machining conditions
- Normal machining conditions
- Unfavourable machining conditions

DN**	L	I.C	S	d
15 06	15.5	12.7	6.35	5.16

**Turning inserts**

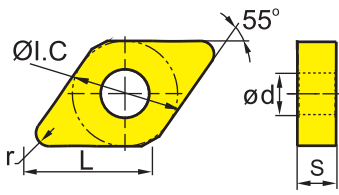

DN** negative insert				HC <sup>1</sup> (CVD)					HC <sup>1</sup> (PVD)			HT	HC <sup>2</sup>	HW															
				<b>P</b>	●●●●●●●●●●					●●●●●	●●●●●	●●●●●																	
				<b>M</b>		●●●●●●●●●●			●●●●●●●●●●	●●●●●	●●●●●	●●●●●																	
				<b>K</b>			●●●●●●●●●●																						
				<b>N</b>				●●●●●					●●●●●	●●●●●															
				<b>S</b>					●●●●●●●●●●					●●●●●	●●●●●														
				<b>H</b>																									
ISO	r	a <sub>p</sub>	f	YBC103	YB6315	YBC152	YBC203	YBC252	YBC352	YBM153	YBM253	YBD102	YB7315	YBD152	YBD152C	YBG101	YBG102	YBG105	YBG205	YB9320	YPD201	YBS103	YNG151	YNT251	YNG151C	YD101	YD201		
Flat	<b>DNMA150604</b>	0.4	0.2-6.0	0.1-0.3								●	○																
	<b>DNMA150608</b>	0.8	0.2-6.0	0.1-0.6								●	●																
	<b>DNMA150612</b>	1.2	0.2-6.0	0.15-0.70								●	●																
Medium Cut	<b>DNMA150616</b>	1.6	0.2-6.0	0.2-0.8										○															
ER	<b>DNMG150608-ER</b>	0.8	2-6	0.15-0.55								○																	
	<b>DNMG150612-ER</b>	1.2	2-6	0.25-0.80								○																	
Roughing																													

● Ex stock ○ On demand  
 YBC152F, YBC252F, YBM153F, YBM253F available

HC<sup>1</sup> Coated carbide  
 HT Uncoated cermet  
 HC<sup>2</sup> Coated cermet  
 HW Uncoated carbide

**Tool holder**

DDJNR/L	PDJNR/L	PDNRR/L	MDJNR/L	MDPNN	S***-PDSNR/L	S***-PDUNR/L
Kr: 93°	Kr: 93°	Kr: 63°	Kr: 93°	Kr: 62°30'	Kr: 62°30'	Kr: 93°
A231	A240	A241	A254	A255	A326	A327

System code > A48

Grade selection > A42

Technical info > A501

Cutting data > A366



A

Turning

B

Milling

C

Drilling

D

Technical Information

E

Index

**A**

Turning

- Ideal machining conditions
- ⊗ Normal machining conditions
- ⊗ Unfavourable machining conditions

DNMM	L	I.C	S	d
15 06	15.5	12.7	6.35	5.16

## Turning inserts

DN** negative insert		HC <sup>1</sup> (CVD)						HC <sup>1</sup> (PVD)			HT	HC <sup>2</sup>	HW		
	<b>P</b>	●	●	●	⊗	⊗	⊗				●	⊗	●		
	<b>M</b>						●	⊗	●	●	⊗	⊗	●	●	
	<b>K</b>														
	<b>N</b>									●	●			●	⊗
	<b>S</b>									●	●	⊗	⊗	●	⊗
	<b>H</b>														

**B**

Milling

	ISO	r	a <sub>p</sub>	f	YBC103	YB6315	YBC152	YBC203	YBC252	YBC352	YBM153	YBM253	YBD102	YB7315	YBD152	YBD152C	YBG101	YBG102	YBG105	YBG205	YB9320	YPD201	YBS103	YNG151	YNT251	YNG151C	YD101	YD201
					DR	<b>DNMM150608-DR</b>	0.8	0.7-6.0	0.20-0.55		●	●																
 Roughing	<b>DNMM150612-DR</b>	1.2	1-6	0.25-0.70		●	●	●																				
	<b>DNMM150616-DR</b>	1.6	1.5-6.0	0.32-0.90		●	●																					
	ER	<b>DNMM150608-ER</b>	0.8	0.7-6.0	0.20-0.55								○															
 Roughing	<b>DNMM150612-ER</b>	1.2	1-6	0.25-0.70									○															
	HDR	<b>DNMM150608-HDR</b>	0.8	1-7	0.25-0.60		●	○																				
	 Roughing	<b>DNMM150612-HDR</b>	1.2	1-7	0.3-0.8		○																					
<b>DNMM150616-HDR</b>		1.6	1.5-7.0	0.4-1.0		○																						
LR		<b>DNMM150608-LR</b>	0.8	2-6	0.1-0.6		●	●			●																	
 Roughing	<b>DNMM150612-LR</b>	1.2	2-6	0.2-0.8			●				○																	
	<b>DNMM150616-LR</b>	1.6	2-6	0.25-1.00		●	●																					

**C**

Drilling

**D**

Technical Information

● Ex stock   ○ On demand  
 YBC152F, YBC252F, YBM153F, YBM253F available

HC<sup>1</sup> Coated carbide  
 HT Uncoated cermet  
 HC<sup>2</sup> Coated cermet  
 HW Uncoated carbide

**E**

Index

Tool holder						
<b>DDJNR/L</b> Kr: 93°	<b>PDJNR/L</b> Kr: 93°	<b>PDNNR/L</b> Kr: 63°	<b>MDJNR/L</b> Kr: 93°	<b>MDPNN</b> Kr: 62°30'	<b>S***-PDSNR/L</b> Kr: 62°30'	<b>S***-PDUNR/L</b> Kr: 93°
A231	A240	A241	A254	A255	A326	A327



- Ideal machining conditions
- Normal machining conditions
- Unfavourable machining conditions

SNMG	L	I.C	S	d
09 03	9.525	9.525	3.18	3.81
12 04	12.7	12.7	4.76	5.16

**Turning inserts**

SN** negative insert				HC <sup>1</sup> (CVD)								HC <sup>1</sup> (PVD)			HT	HC <sup>2</sup>	HW										
				P	M	K	N	S	H																		
ISO	r	a <sub>p</sub>	f	YBC103	YB6315	YBC152	YBC203	YBC252	YBC352	YBM153	YBM253	YBD102	YB7315	YBD152	YBD152C	YBG101	YBG102	YBG105	YBG205	YB9320	YPD201	YBS103	YNG151	YNT251	YNG151C	YD101	YD201
ADF	<b>SNMG120404-ADF</b>	0.4	0.5-5.0	0.1-0.3	●															●							
Finishing	<b>SNMG120408-ADF</b>	0.8	0.5-5.0	0.12-0.50	●															●							
	<b>SNMG120412-ADF</b>	1.2	1-5	0.2-0.6	●															●							
	DF	<b>SNMG120408-DF</b>	0.8	0.3-1.5	0.1-0.4		●	●																			
Finishing	<b>SNMG120412-DF</b>	1.2	0.35-1.50	0.15-0.50		●	●																				
	SF	<b>SNMG090304-SF</b>	0.4	0.05-0.50	0.05-0.20																				●		
Finishing	<b>SNMG090308-SF</b>	0.8	0.05-0.50	0.10-0.35																					○		
	<b>SNMG120404-SF</b>	0.4	0.05-0.50	0.05-0.20																					○		
	<b>SNMG120408-SF</b>	0.8	0.05-0.50	0.10-0.35																					○		

● Ex stock ○ On demand  
 YBC152F, YBC252F, YBM153F, YBM253F available

HC<sup>1</sup> Coated carbide  
 HT Uncoated cermet  
 HC<sup>2</sup> Coated cermet  
 HW Uncoated carbide

Tool holder						
DSB NR/L	PSB NR/L	PSD NN	PSK NR/L	PSS NR/L	MSB NR/L	MSR NR/L
Kr: 75°	Kr: 75°	Kr: 45°	Kr: 75°	Kr: 45°	Kr: 75°	Kr: 75°
A232	A242	A244	A245	A246	A256	A257
MSK NR/L	MSD NN	S***-PSK NR/L				
Kr: 75°	Kr: 45°	Kr: 75°				
A258	A259	A329				



**A**

Turning

**B**

Milling

**C**

Drilling

**D**

Technical Information

**E**

Index

- Ideal machining conditions
- ⊗ Normal machining conditions
- ⊗ Unfavourable machining conditions

SNMG	L	I.C	S	d
<b>09 03</b>	9.525	9.525	3.18	3.81
<b>12 04</b>	12.7	12.7	4.76	5.16
<b>15 06</b>	15.875	15.875	6.35	6.35

## Turning inserts

SN** negative insert				HC <sup>1</sup> (CVD)								HC <sup>1</sup> (PVD)		HT	HC <sup>2</sup>	HW																
	P	M	K	N	S	H	YBC103	YB6315	YBC152	YBC203	YBC252	YBC352	YBM153	YBM253	YBD102	YB7315	YBD152	YBD152C	YBG101	YBG102	YBG105	YBG205	YB9320	YPD201	YBS103	YNG151	YNT251	YNG151C	YD101	YD201		
	ISO	r	a <sub>p</sub>	f																												
		<b>SNMG090304-EF</b>	0.4	0.5-2.0	0.05-0.30									●									●									
		<b>SNMG090308-EF</b>	0.8	0.5-2.0	0.05-0.40									●										●								
		<b>SNMG090312-EF</b>	1.2	0.5-2.0	0.05-0.45									○																		
		<b>SNMG120404-EF</b>	0.4	0.8-3.0	0.05-0.30																				●							
<b>SNMG120408-EF</b>		0.8	0.8-3.0	0.1-0.4																				●								
<b>SNMG120412-EF</b>		1.2	0.8-3.0	0.15-0.45										○										●								
<b>SNMG150608-EF</b>		0.8	1-4	0.1-0.4										○																		
<b>SNMG150612-EF</b>		1.2	1-4	0.15-0.45										○																		



● Ex stock   ○ On demand  
 YBC152F, YBC252F, YBM153F, YBM253F available

HC<sup>1</sup> Coated carbide  
 HT Uncoated cermet  
 HC<sup>2</sup> Coated cermet  
 HW Uncoated carbide

Tool holder						
DSB NR/L	PSB NR/L	PSD NN	PSK NR/L	PSS NR/L	MSB NR/L	MSR NR/L
Kr: 75°	Kr: 75°	Kr: 45°	Kr: 75°	Kr: 45°	Kr: 75°	Kr: 75°
A232	A242	A244	A245	A246	A256	A257
MSK NR/L	MSD NN	S***-PSK NR/L				
Kr: 75°	Kr: 45°	Kr: 75°				
A258	A259	A329				





SNMG	L	I.C	S	d
12 04	12.7	12.7	4.76	5.16
15 06	15.875	15.875	6.35	6.35
19 06	19.05	19.05	6.35	7.94

-  Ideal machining conditions
-  Normal machining conditions
-  Unfavourable machining conditions

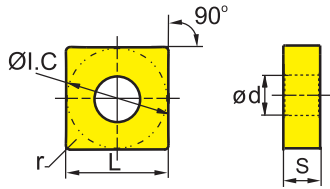
**Turning inserts**





					HC <sup>1</sup> (CVD)								HC <sup>1</sup> (PVD)				HT	HC <sup>2</sup>	HW										
					P	M	K	N	S	H																			
ISO					r	a <sub>p</sub>	f																						
					YBC103	YB6315	YBC152	YBC203	YBC252	YBC352	YBM153	YBM253	YBD102	YB7315	YBD152	YBD152C	YBG101	YBG102	YBG105	YBG205	YB9320	YPD201	YBS103	YNG151	YNT251	YNG151C	YD101	YD201	
XF 	<b>SNMG120404-XF</b>	0.4	0.5-2.5	0.1-0.25	●	●																							
	<b>SNMG120408-XF</b>	0.8	0.5-2.5	0.1-0.30	●	●																							
XM 	<b>SNMG120404-XM</b>	0.4	1-4.2	0.2-0.4	○	○																							
	<b>SNMG120408-XM</b>	0.8	1-4.2	0.2-0.4	●	●																							
	<b>SNMG120412-XM</b>	1.2	1-4.2	0.2-0.6	●	●																							
	<b>SNMG120416-XM</b>	1.6	1-4.2	0.2-0.65	○	○																							
	<b>SNMG150608-XM</b>	0.8	1-5.25	0.2-0.4	●	●																							
	<b>SNMG150612-XM</b>	1.2	1-5.25	0.2-0.6	●	●																							
	<b>SNMG150616-XM</b>	1.6	1-5.25	0.2-0.65	○	●																							
	<b>SNMG190608-XM</b>	0.8	1-6.65	0.2-0.4	○	○																							
	<b>SNMG190612-XM</b>	1.2	1-6.65	0.2-0.6	○	○																							
	<b>SNMG190616-XM</b>	1.6	1-6.65	0.2-0.65	○	○																							
<b>SNMG190624-XM</b>	2.4	1-6.65	0.2-1.2	○	○																								

● Ex stock ○ On demand

HC<sup>1</sup> Coated carbide  
 HT Uncoated cermet  
 HC<sup>2</sup> Coated cermet  
 HW Uncoated carbide

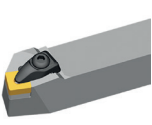
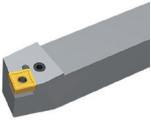
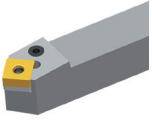
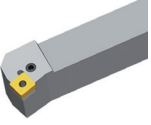
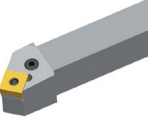
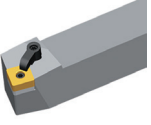
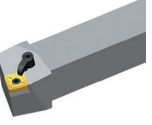
**Tool holder**

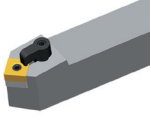
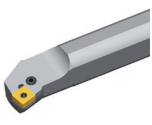
DSBNR/L	PSBNR/L	PSDNN	PSKNR/L	PSSNR/L	MSBNR/L	MSRNR/L
Kr: 75°	Kr: 75°	Kr: 45°	Kr: 75°	Kr: 45°	Kr: 75°	Kr: 75°
						
A232	A242	A244	A245	A246	A256	A257
MSKNR/L	MSDNN	S***-PSKNR/L				
Kr: 75°	Kr: 45°	Kr: 75°				
						
A258	A259	A329				

System code > A48

Grade selection > A42

Technical info > A501

Cutting data > A366



A Turning  
 B Milling  
 C Drilling  
 D Technical Information  
 E Index

**A**

Turning

**B**

Milling

**C**

Drilling

**D**

Technical Information

**E**

Index

SNMG	L	I.C	S	d
<b>09 03</b>	9.525	9.525	3.18	3.81
<b>12 04</b>	12.7	12.7	4.76	5.16
<b>15 06</b>	15.875	15.875	6.35	6.35
<b>19 06</b>	19.05	19.05	6.35	7.94

- Ideal machining conditions
- ⊗ Normal machining conditions
- ⊗ Unfavourable machining conditions



## Turning inserts

SN** negative insert				HC <sup>1</sup> (CVD)								HC <sup>1</sup> (PVD)			HT	HC <sup>2</sup>	HW											
ISO	r	a <sub>p</sub>	f	P	M	K	N	S	H																			
				YBC103	YB6315	YBC152	YBC203	YBC252	YBC352	YBM153	YBM253	YBD102	YB7315	YBD152	YBD152C	YBG101	YBG102	YBG105	YBG205	YB9320	YPD201	YBS103	YNG151	YNT251	YNG151C	YD101	YD201	
PM  Medium Cut	<b>SNMG090304-PM</b>	0.4	0.4-4.5	0.1-0.3	●	●	●	●	●	●																		
	<b>SNMG090308-PM</b>	0.8	0.5-4.5	0.15-0.50																								
	<b>SNMG090312-PM</b>	1.2	0.6-4.5	0.2-0.6																								
	<b>SNMG120404-PM</b>	0.4	0.4-6.0	0.1-0.3			●	○																				
	<b>SNMG120408-PM</b>	0.8	0.5-6.0	0.15-0.50			●	●			○																	
	<b>SNMG120412-PM</b>	1.2	0.8-6.0	0.18-0.60			●	●			○																	
	<b>SNMG120416-PM</b>	1.6	1-6	0.23-0.65			○	○			○	○																
	<b>SNMG150608-PM</b>	0.8	0.7-7.5	0.14-0.50			○	○																				
	<b>SNMG150612-PM</b>	1.2	0.8-7.5	0.18-0.60			○	●			●	●																
	<b>SNMG190612-PM</b>	1.2	1.0-7.5	0.20-0.65			○	●			●	●																

● Ex stock   ○ On demand  
 YBC152F, YBC252F, YBM153F, YBM253F available

HC<sup>1</sup> Coated carbide  
 HT Uncoated cermet  
 HC<sup>2</sup> Coated cermet  
 HW Uncoated carbide

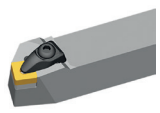
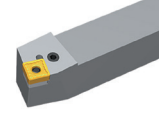
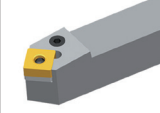
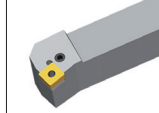
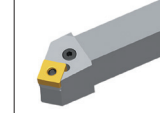
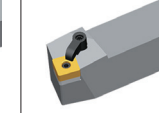
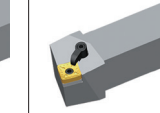
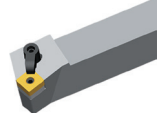
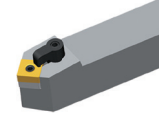
### Tool holder

DSBNR/L	PSBNR/L	PSDNN	PSKNR/L	PSSNR/L	MSBNR/L	MSRNR/L
Kr: 75°	Kr: 75°	Kr: 45°	Kr: 75°	Kr: 45°	Kr: 75°	Kr: 75°
						
A232	A242	A244	A245	A246	A256	A257
MSKNR/L	MSDNN	S***-PSKNR/L				
Kr: 75°	Kr: 45°	Kr: 75°				
						
A258	A259	A329				



SNMG	L	I.C	S	d
09 03	9.525	9.525	3.18	3.81
12 04	12.7	12.7	4.76	5.16
15 06	15.875	15.875	6.35	6.35
19 06	19.05	19.05	6.35	7.94

- Ideal machining conditions
- ⊗ Normal machining conditions
- ⊗ Unfavourable machining conditions

**Turning inserts**

SN** negative insert				HC <sup>1</sup> (CVD)								HC <sup>1</sup> (PVD)			HT	HC <sup>2</sup>	HW										
				P	M	K	N	S	H																		
ISO	r	a <sub>p</sub>	f	YBC103	YB6315	YBC152	YBC203	YBC252	YBC352	YBM153	YBM253	YBD102	YB7315	YBD152	YBD152C	YBG101	YBG102	YBG105	YBG205	YB9320	YPD201	YBS103	YNG151	YNT251	YNG151C	YD101	YD201
<b>DM</b>  Medium Cut	<b>SNMG090304-DM</b>	0.4	0.4-4.5	0.1-0.3	●	●																					
	<b>SNMG090308-DM</b>	0.8	0.5-4.5	0.15-0.50	●	●																					
	<b>SNMG120404-DM</b>	0.4	0.4-6.0	0.1-0.3	●	●																					
	<b>SNMG120408-DM</b>	0.8	0.5-6.0	0.15-0.50	●	●	○																				
	<b>SNMG120412-DM</b>	1.2	0.8-6.0	0.18-0.60	●	●																					
	<b>SNMG120416-DM</b>	1.6	1-6	0.23-0.65	○	●																					
	<b>SNMG150608-DM</b>	0.8	0.8-7.5	0.1-0.5	●	●																					
	<b>SNMG150612-DM</b>	1.2	0.8-7.5	0.18-0.60	●	●																					
	<b>SNMG190612-DM</b>	1.2	1-9	0.18-0.60	●	●																					
	<b>SNMG190616-DM</b>	1.6	1-9	0.23-0.65	○	●																					
<b>EG</b>  Medium Cut	<b>SNMG120408-EG</b>	0.8	0.5-4.0	0.1-0.5						●								●	●								
	<b>SNMG120412-EG</b>	1.2	0.5-4.0	0.2-0.6							●								●								

● Ex stock ○ On demand  
 YBC152F, YBC252F, YBM153F, YBM253F available

HC<sup>1</sup> Coated carbide  
 HT Uncoated cermet  
 HC<sup>2</sup> Coated cermet  
 HW Uncoated carbide

Tool holder						
DSBNR/L	PSBNR/L	PSDNN	PSKNR/L	PSSNR/L	MSBNR/L	MSRNR/L
Kr: 75°	Kr: 75°	Kr: 45°	Kr: 75°	Kr: 45°	Kr: 75°	Kr: 75°
A232	A242	A244	A245	A246	A256	A257
MSKNR/L	MSDNN	S***-PSKNR/L				
Kr: 75°	Kr: 45°	Kr: 75°				
A258	A259	A329				

**A** Turning  
**B** Milling  
**C** Drilling  
**D** Technical Information  
**E** Index

# General turning Negative inserts

**A**

Turning

- Ideal machining conditions
- ⊗ Normal machining conditions
- ⊗ Unfavourable machining conditions

SNMG	L	I.C	S	d
12 04	12.7	12.7	4.76	5.16
15 06	15.875	15.875	6.35	6.35

## Turning inserts

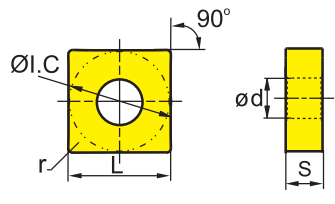

SN** negative insert				HC <sup>1</sup> (CVD)								HC <sup>1</sup> (PVD)		HT	HC <sup>2</sup>	HW															
				P	M	K	N	S	H																						
	ISO	r	a <sub>p</sub>	f	YBC103	YB6315	YBC152	YBC203	YBC252	YBC352	YBM153	YBM253	YBD102	YB7315	YBD152	YBD152C	YBG101	YBG102	YBG105	YBG205	YB9320	YPD201	YBS103	YNG151	YNT251	YNG151C	YD101	YD201			
EM  Medium Cut	SNMG120404-EM	0.4	0.50-6.35	0.05-0.30																●											
	SNMG120408-EM	0.8	0.50-6.35	0.20-0.45							●	●								●											
	SNMG120412-EM	1.2	0.50-6.35	0.25-0.60							●	●								●											
	SNMG120416-EM	1.6	0.50-6.35	0.30-0.75																											
	SNMG150612-EM	1.2	0.5-8.0	0.25-0.60							○	●									●										
	SNMG150616-EM	1.6	0.5-8.0	0.30-0.75																	●										
TC  Medium Cut	SNMG120404-TC	0.4	0.5-5.0	0.08-0.25										●																	
	SNMG120408-TC	0.8	0.5-5.0	0.15-0.40										●	●																
	SNMG120412-TC	1.2	0.5-5.0	0.2-0.5										●	●																
	SNMG150616-TC	1.6	1-7	0.2-0.7										●																	
TK  Medium Cut	SNMG120412-TK	1.2	0.2-0.4	0.2-0.45										●																	

● Ex stock ○ On demand  
YBC152F, YBC252F, YBM153F, YBM253F available

HC<sup>1</sup> Coated carbide  
HT Uncoated cermet  
HC<sup>2</sup> Coated cermet  
HW Uncoated carbide

**B**

Milling

**C**

Drilling

**D**

Technical Information

**E**

Index

Tool holder						
DSBNR/L	PSBNR/L	PSDNN	PSKNR/L	PSSNR/L	MSBNR/L	MSRNR/L
Kr: 75°	Kr: 75°	Kr: 45°	Kr: 75°	Kr: 45°	Kr: 75°	Kr: 75°
A232	A242	A244	A245	A246	A256	A257
MSKNR/L	MSDNN	S***-PSKNR/L				
Kr: 75°	Kr: 45°	Kr: 75°				
A258	A259	A329				



SNMG	L	I.C	S	d
12 04	12.7	12.7	4.76	5.16
15 06	15.875	15.875	6.35	6.35
19 06	19.05	19.05	6.35	7.94
25 09	25.4	25.4	9.525	9.12

- Ideal machining conditions
- ⊗ Normal machining conditions
- ⊗ Unfavourable machining conditions

**Turning inserts**

SN** negative insert					HC <sup>1</sup> (CVD)								HC <sup>1</sup> (PVD)			HT	HC <sup>2</sup>	HW											
					P	M	K	N	S	H																			
ISO	r	a <sub>p</sub>	f	YBC103	YB6315	YBC152	YBC203	YBC252	YBC352	YBM153	YBM253	YBD102	YB7315	YBD152	YBD152C	YBG101	YBG102	YBG105	YBG205	YB9320	YPD201	YBS103	YNG151	YNT251	YNG151C	YD101	YD201		
 Medium Cut	SNMG120408-NM	0.8	0.5-5.0	0.1-0.4												○		●									○		
	SNMG120412-NM	1.2	0.5-5.0	0.15-0.50														○											
 DR Roughing	SNMG120408-DR	0.8	0.7-7.0	0.2-0.5		○	●				●	●																	
	SNMG120412-DR	1.2	1-7	0.25-0.70		●	●	●				○	●																
	SNMG120416-DR	1.6	1.5-7.0	0.32-0.75		○	●					●	●																
	SNMG150612-DR	1.2	1-8	0.25-0.70					●				○	●															
	SNMG150616-DR	1.6	1.5-8.0	0.3-0.8		○	●					○	○																
	SNMG190612-DR	1.2	1-10	0.25-0.70		●	●	●						●															
	SNMG190616-DR	1.6	1.5-10.0	0.3-0.8	○	●	●	●					○	●															
SNMG190624-DR	2.4	2-10	0.32-0.90					●	○																				
SNMG250924-DR	2.4	2-15	0.4-1.2					●	○																				

● Ex stock ○ On demand  
YBC152F, YBC252F, YBM153F, YBM253F available

HC<sup>1</sup> Coated carbide  
HT Uncoated cermet  
HC<sup>2</sup> Coated cermet  
HW Uncoated carbide

Tool holder						
DSBNR/L	PSBNR/L	PSDNN	PSKNR/L	PSSNR/L	MSBNR/L	MSRNR/L
Kr: 75°	Kr: 75°	Kr: 45°	Kr: 75°	Kr: 45°	Kr: 75°	Kr: 75°
A232	A242	A244	A245	A246	A256	A257
MSKNR/L	MSDNN	S***-PSKNR/L				
Kr: 75°	Kr: 45°	Kr: 75°				
A258	A259	A329				

**A**

Turning

**B**

Milling

**C**

Drilling

**D**

Technical Information

**E**

Index

- Ideal machining conditions
- ⊗ Normal machining conditions
- ⊗ Unfavourable machining conditions

SNMG	L	I.C	S	d
12 04	12.7	12.7	4.76	5.16
15 06	15.875	15.875	6.35	6.35
19 06	19.05	19.05	6.35	7.94

## Turning inserts

SN** negative insert				HC <sup>1</sup> (CVD)								HC <sup>1</sup> (PVD)			HT	HC <sup>2</sup>	HW										
				P	M	K	N	S	H																		
ISO	r	a <sub>p</sub>	f	YBC103	YB6315	YBC152	YBC203	YBC252	YBC352	YBM153	YBM253	YBD102	YB7315	YBD152	YBD152C	YBG101	YBG102	YBG105	YBG205	YB9320	YPD201	YBS103	YNG151	YNT251	YNG151C	YD101	YD201
ER	<b>SNMG120408-ER</b>	0.8	2.0-7.6	0.20-0.55						○	○																
	<b>SNMG120412-ER</b>	1.2	2.0-7.6	0.3-0.6						○	○																
	<b>SNMG150612-ER</b>	1.2	2.0-9.6	0.3-0.6						○	○																
	<b>SNMG190612-ER</b>	1.2	2.0-11.4	0.3-0.6						○	○																
Roughing	<b>SNMG190616-ER</b>	1.6	2.0-11.4	0.35-0.80						○	○																
SNR	<b>SNMG120408-SNR</b>	0.8	1-4	0.2-0.6												●					●						

● Ex stock   ○ On demand  
 YBC152F, YBC252F, YBM153F, YBM253F available

HC<sup>1</sup> Coated carbide  
 HT Uncoated cermet  
 HC<sup>2</sup> Coated cermet  
 HW Uncoated carbide

### Tool holder

DSBNR/L	PSBNR/L	PSDNN	PSKNR/L	PSSNR/L	MSBNR/L	MSRNR/L
Kr: 75°	Kr: 75°	Kr: 45°	Kr: 75°	Kr: 45°	Kr: 75°	Kr: 75°
A232	A242	A244	A245	A246	A256	A257
MSKNR/L	MSDNN	S***-PSKNR/L				
Kr: 75°	Kr: 45°	Kr: 75°				
A258	A259	A329				

System code > A48

Grade selection > A42

Technical info > A501

Cutting data > A366



SNMM	L	I.C	S	d
15 06	15.875	15.875	6.35	6.35
19 06	19.05	19.05	6.35	7.94
25 07	25.4	25.4	7.94	9.12
25 09	25.4	25.4	9.525	9.12

- Ideal machining conditions
- Normal machining conditions
- Unfavourable machining conditions

**Turning inserts**

SN** negative insert				HC <sup>1</sup> (CVD)								HC <sup>1</sup> (PVD)		HT	HC <sup>2</sup>	HW													
				P	M	K	N	S	H																				
ISO	r	a <sub>p</sub>	f	YBC103	YB6315	YBC152	YBC203	YBC252	YBC352	YBM153	YBM253	YBD102	YB7315	YBD152	YBD152C	YBG101	YBG102	YBG105	YBG205	YB9320	YPD201	YBS103	YNG151	YNT251	YNG151C	YD101	YD201		
<b>DR</b>  Roughing	SNMM150612-DR	1.2	1-7	0.25-0.60					●																				
	SNMM150616-DR	1.6	1.5-9.0	0.32-0.90		○			●	●																			
	SNMM190608-DR	0.8	2.0-10.5	0.25-0.50					○																				
	SNMM190612-DR	1.2	2.0-10.5	0.25-0.60						●	●	●																	
	SNMM190616-DR	1.6	2.0-10.5	0.35-0.90						●	●	●																	
	SNMM190624-DR	2.4	2.0-10.5	0.4-1.1						●	●	●																	
	SNMM250716-DR	1.6	2.5-12.5	0.4-1.0							●																		
	SNMM250724-DR	2.4	2.5-12.5	0.5-1.2			○				●																		
	SNMM250924-DR	2.4	2.5-12.5	0.5-1.2							●	●																	
<b>ER</b>  Roughing	SNMM250724-ER	2.4	2.8-18.0	0.45-1.40						●	○	●																	
	SNMM250732-ER	3.2	2.8-18.0	0.32-1.40						●																			
	SNMM250924-ER	2.4	2.8-18.0	0.45-1.40						●	○	○																	
	SNMM250932-ER	3.2	2.8-18.0	0.55-1.80							●																		

● Ex stock ○ On demand  
 YBC152F, YBC252F, YBM153F, YBM253F available

HC<sup>1</sup> Coated carbide  
 HT Uncoated cermet  
 HC<sup>2</sup> Coated cermet  
 HW Uncoated carbide

Tool holder						
DSBNR/L	PSBNR/L	PSDNN	PSKNR/L	PSSNR/L	MSBNR/L	MSRNR/L
Kr: 75°	Kr: 75°	Kr: 45°	Kr: 75°	Kr: 45°	Kr: 75°	Kr: 75°
A232	A242	A244	A245	A246	A256	A257
MSKNR/L	MSDNN					
Kr: 75°	Kr: 45°					
A258	A259					



**A**

Turning

**B**

Milling

**C**

Drilling

**D**

Technical Information

**E**

Index

SNMM	L	I.C	S	d
12 04	12.7	12.7	4.76	5.16
15 06	15.875	15.875	6.35	6.35
19 06	19.05	19.05	6.35	7.94
25 09	25.4	25.4	9.525	9.12

- Ideal machining conditions
- Normal machining conditions
- Unfavourable machining conditions



## Turning inserts

SN** negative insert					HC <sup>1</sup> (CVD)								HC <sup>1</sup> (PVD)		HT	HC <sup>2</sup>	HW													
ISO	r	a <sub>p</sub>	f	YBC103	YB6315	YBC152	YBC203	YBC252	YBC352	YBM153	YBM253	YBD102	YB7315	YBD152	YBD152C	YBG101	YBG102	YBG105	YBG205	YB9320	YPD201	YBS103	YNG151	YNT251	YNG151C	YD101	YD201			
																												P	M	K
LR  Roughing	SNMM120408-LR	0.8	1-6	0.1-0.5	○	●																								
	SNMM120412-LR	1.2	1-6	0.2-0.6	○	●																								
	SNMM120416-LR	1.6	1-6	0.25-0.70				○																						
	SNMM150612-LR	1.2	1.5-7.0	0.1-0.5						●																				
	SNMM150616-LR	1.6	1.5-7.0	0.1-0.5				○	○																					
	SNMM190612-LR	1.2	2-10	0.25-0.70				○	●																					
	SNMM190616-LR	1.6	2-10	0.3-1.0				○	●																					
	SNMM190624-LR	2.4	2-10	0.3-1.1				○	●																					
	SNMM250924-LR	2.4	3.0-12.5	0.3-1.2				○	●	○																				

● Ex stock    ○ On demand  
 YBC152F, YBC252F, YBM153F, YBM253F available

HC<sup>1</sup> Coated carbide  
 HT Uncoated cermet  
 HC<sup>2</sup> Coated cermet  
 HW Uncoated carbide

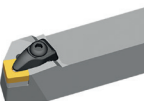
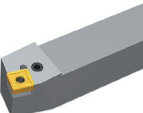
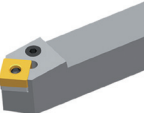
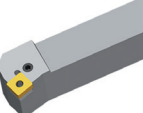
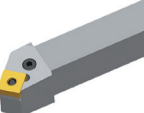
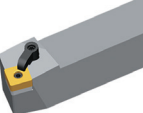
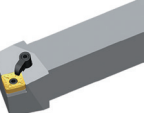
### Tool holder

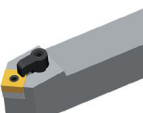
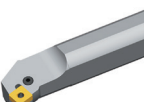
DSB NR/L Kr: 75°	PSB NR/L Kr: 75°	PSD NN Kr: 45°	PSK NR/L Kr: 75°	PSS NR/L Kr: 45°	MSB NR/L Kr: 75°	MSR NR/L Kr: 75°
						
A232	A242	A244	A245	A246	A256	A257
MSK NR/L Kr: 75°	MSD NN Kr: 45°	S***-PSK NR/L Kr: 75°				
						
A258	A259	A329				

System code > A48

Grade selection > A42



Technical info > A501

Cutting data > A366

SNMM	L	I.C	S	d
12 04	12.7	12.7	4.76	5.16
15 06	15.875	15.875	6.35	6.35
19 06	19.05	19.05	6.35	7.94
25 07	25.4	25.4	7.94	9.12
25 09	25.4	25.4	9.525	9.12



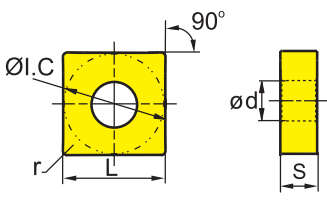



- Ideal machining conditions
- Normal machining conditions
- Unfavourable machining conditions

**Turning inserts**

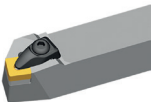
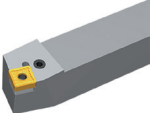
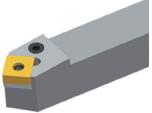
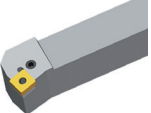
SN** negative insert				HC <sup>1</sup> (CVD)								HC <sup>1</sup> (PVD)			HT	HC <sup>2</sup>	HW											
				P	M	K	N	S	H																			
ISO	r	a <sub>p</sub>	f	YBC103	YB6315	YBC152	YBC203	YBC252	YBC352	YBM153	YBM253	YBD102	YB7315	YBD152	YBD152C	YBG101	YBG102	YBG105	YBG205	YB9320	YPD201	YBS103	YNG151	YNT251	YNG151C	YD101	YD201	
HDR  Roughing	<b>SNMM120408-HDR</b>	0.8	1-6	0.1-0.6					●																			
	<b>SNMM120412-HDR</b>	1.2	1.5-6.0	0.2-0.7					○																			
	<b>SNMM150608-HDR</b>	0.8	1-7	0.2-0.6						○																		
	<b>SNMM150612-HDR</b>	1.2	1-7	0.25-0.70			●	●																				
	<b>SNMM150616-HDR</b>	1.6	1.5-9.0	0.32-1.00						○																		
	<b>SNMM190612-HDR</b>	1.2	2.0-10.5	0.25-0.70			○	○																				
	<b>SNMM190616-HDR</b>	1.6	2.0-10.5	0.35-1.00			●	●				○																
	<b>SNMM190624-HDR</b>	2.4	2.0-10.5	0.4-1.2			●	●																				
	<b>SNMM250724-HDR</b>	2.4	2.5-12.5	0.5-1.4								●																
	<b>SNMM250924-HDR</b>	2.4	2.5-12.5	0.5-1.4			●	●	●																			

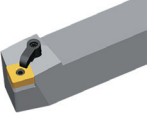
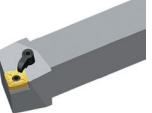
● Ex stock ○ On demand  
 YBC152F, YBC252F, YBM153F, YBM253F available

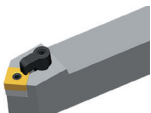
HC<sup>1</sup> Coated carbide  
 HT Uncoated cermet  
 HC<sup>2</sup> Coated cermet  
 HW Uncoated carbide

Tool holder						
DSBNR/L	PSBNR/L	PSDNN	PSKNR/L	PSSNR/L	MSBNR/L	MSRNR/L
Kr: 75°	Kr: 75°	Kr: 45°	Kr: 75°	Kr: 45°	Kr: 75°	Kr: 75°
						
A232	A242	A244	A245	A246	A256	A257
MSKNR/L	MSDNN	S***-PSKNR/L				
Kr: 75°	Kr: 45°	Kr: 75°				
						
A258	A259	A329				

**A**

Turning

- Ideal machining conditions
- Normal machining conditions
- Unfavourable machining conditions

SNMM	L	I.C	S	d
<b>19 06</b>	19.05	19.05	6.35	7.94
<b>25 09</b>	25.4	25.4	9.525	9.12

## Turning inserts

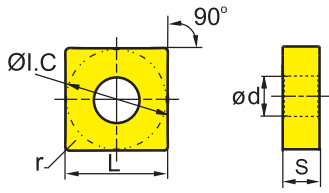

SN** negative insert				HC <sup>1</sup> (CVD)										HC <sup>1</sup> (PVD)			HT	HC <sup>2</sup>	HW									
				<b>P</b>																								
				<b>M</b>																								
				<b>K</b>																								
				<b>N</b>																								
				<b>S</b>																								
				<b>H</b>																								
ISO		r	a <sub>p</sub>	f	YBC103	YB6315	YBC152	YBC203	YBC252	YBC352	YBM153	YBM253	YBD102	YB7315	YBD152	YBD152C	YBG101	YBG102	YBG105	YBG205	YB9320	YPD201	YBS103	YNG151	YNT251	YNG151C	YD101	YD201
HPR	<b>SNMM190616-HPR</b>	1.6	2.0-10.5	0.35-1.00																								
	<b>SNMM190624-HPR</b>	2.4	2.0-10.5	0.4-1.2																								
	<b>SNMM250924-HPR</b>	2.4	2.0-12.5	0.5-1.4																								
Roughing																												

● Ex stock    ○ On demand  
 YBC152F, YBC252F, YBM153F, YBM253F available

HC<sup>1</sup> Coated carbide  
 HT Uncoated cermet  
 HC<sup>2</sup> Coated cermet  
 HW Uncoated carbide

**B**

Milling

**C**

Drilling

**D**

Technical Information

**E**

Index

Tool holder						
PSBNR/L	PSDNN	PSKNR/L	PSSNR/L	MSBNR/L	MSRNR/L	MSKNR/L
Kr: 75°	Kr: 45°	Kr: 75°	Kr: 45°	Kr: 75°	Kr: 75°	Kr: 75°
A242	A244	A245	A246	A256	A257	A258



SNMG	L	I.C	S	d
12 04	12.7	12.7	4.76	5.16
25 07	25.4	25.4	7.94	9.12
25 09	25.4	25.4	9.525	9.12

- Ideal machining conditions
- ⊗ Normal machining conditions
- ⊗ Unfavourable machining conditions

**Turning inserts**

SN** negative insert		HC <sup>1</sup> (CVD)					HC <sup>1</sup> (PVD)			HT	HC <sup>2</sup>	HW	
	<b>P</b>	●	●	●	●	⊗			●	⊗	●		
	<b>M</b>					●	⊗	●	●	●	●	●	
	<b>K</b>					●	⊗	●	●	●			
	<b>N</b>							●	●			●	⊗
	<b>S</b>								●	●	●	●	⊗
	<b>H</b>												

ISO		r	a <sub>p</sub>	f	YBC103	YB6315	YBC152	YBC203	YBC252	YBC352	YBM153	YBM253	YBD102	YBD315	YBD152	YBD152C	YBG101	YBG102	YBG105	YBG205	YB9320	YPD201	YBS103	YNG151	YNT251	YNG151C	YD101	YD201	
<b>Basic</b> 	<b>SNMG120408</b>	0.8	0.5-6.0	0.1-0.6		●		●																					
	<b>SNMG120412</b>	1.2	0.5-6.0	0.1-0.7		○		○																					
	<b>SNMG250724</b>	2.4	1-9	0.1-1.1																									
	<b>SNMG250924</b>	2.4	1-9	0.1-1.1																									
<b>Medium Cut</b>																													

● Ex stock   ○ On demand  
 YBC152F, YBC252F, YBM153F, YBM253F available

HC<sup>1</sup> Coated carbide  
 HT Uncoated cermet  
 HC<sup>2</sup> Coated cermet  
 HW Uncoated carbide

Tool holder						
<b>DSBNR/L</b> Kr: 75°	<b>PSBNR/L</b> Kr: 75°	<b>PSDNN</b> Kr: 45°	<b>PSKNR/L</b> Kr: 75°	<b>PSSNR/L</b> Kr: 45°	<b>MSBNR/L</b> Kr: 75°	<b>MSRNR/L</b> Kr: 75°
A232	A242	A244	A245	A246	A256	A257
<b>MSKNR/L</b> Kr: 75°	<b>MSDNN</b> Kr: 45°	<b>S***-PSKNR/L</b> Kr: 75°				
A258	A259	A329				

**A**

Turning

**B**

Milling

**C**

Drilling

**D**

Technical Information



**E**

Index

SN**	L	I.C	S	d
12 04	12.7	12.7	4.76	5.16
15 06	15.875	15.875	6.35	6.35
19 06	19.05	19.05	6.35	7.94
25 07	25.4	25.4	7.94	9.12

- Ideal machining conditions
- ⊗ Normal machining conditions
- ⊗ Unfavourable machining conditions

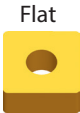
## Turning inserts



SN** negative insert				HC <sup>1</sup> (CVD)								HC <sup>1</sup> (PVD)		HT	HC <sup>2</sup>	HW													
ISO	r	a <sub>p</sub>	f	P	M	K	N	S	H																				
				YBC103	YB6315	YBC152	YBC203	YBC252	YBC352	YBM153	YBM253	YBD102	YB7315	YBD152	YBD152C	YBG101	YBG102	YBG105	YBG205	YB9320	YPD201	YBS103	YNG151	YNT251	YNG151C	YD101	YD201		
Flat 	SNMA120408	0.8	0.5-5.0	0.1-0.5	●	●	●	●	●	●	●	●	●	●	●	●	●	●	●	●	●	●	●	●	●	●	●	●	
	SNMA120412	1.2	0.5-5.0	0.2-0.7							○	○	○	○															
	SNMA120416	1.6	0.5-5.0	0.2-1.0							○	○	○	○															
	SNMA150608	0.8	0.8-7.0	0.1-0.5																									
	SNMA150612	1.2	0.8-7.0	0.2-0.7																									
	SNMA190612	1.2	0.8-7.0	0.2-0.7																									
	SNMA190616	1.6	0.8-7.0	0.3-0.8																									
Basic 	SNMM250724-1	2.4	2.0-12.5	0.3-1.2						●	●																		

● Ex stock    ○ On demand  
YBC152F, YBC252F, YBM153F, YBM253F available

HC<sup>1</sup> Coated carbide  
HT Uncoated cermet  
HC<sup>2</sup> Coated cermet  
HW Uncoated carbide

**D**

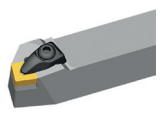
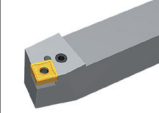
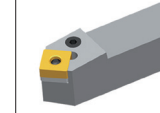
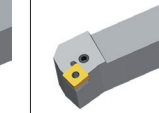
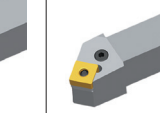
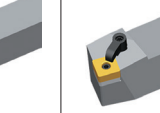
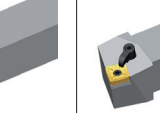
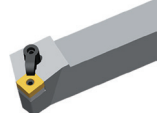
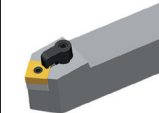
Technical Information

Tool holder						
DSBNR/L Kr: 75°	PSBNR/L Kr: 75°	PSDNN Kr: 45°	PSKNR/L Kr: 75°	PSSNR/L Kr: 45°	MSBNR/L Kr: 75°	MSRNR/L Kr: 75°
						
A232	A242	A244	A245	A246	A256	A257
MSKNR/L Kr: 75°	MSDNN Kr: 45°	S***-PSKNR/L Kr: 75°				
						
A258	A259	A329				



- Ideal machining conditions
- Normal machining conditions
- Unfavourable machining conditions

SNMM	L	I.C	S	d
19 06	19.05	19.05	6.35	7.94
25 09	25.4	25.4	9.525	9.12

### Turning inserts

SN** negative insert				HC <sup>1</sup> (CVD)								HC <sup>1</sup> (PVD)			HT	HC <sup>2</sup>	HW											
				P	●	●	●	●	●	●	●	●	●	●	●	●												
				M	●	●	●	●	●	●	●	●	●	●	●	●	●	●										
				K	●	●	●	●	●	●	●	●	●	●	●	●	●	●	●									
				N	●	●	●	●	●	●	●	●	●	●	●	●	●	●	●									
				S	●	●	●	●	●	●	●	●	●	●	●	●	●	●	●									
				H	●	●	●	●	●	●	●	●	●	●	●	●	●	●	●									
ISO	r	a <sub>p</sub>	f	YBC103	YB6315	YBC152	YBC203	YBC252	YBC352	YBM153	YBM253	YBD102	YB7315	YBD152	YBD152C	YBG101	YBG102	YBG105	YBG205	YB9320	YPD201	YBS103	YNG151	YNT251	YNG151C	YD101	YD201	
Basic 	<b>SNMM190612</b>	1.2	1.5-10.5	0.2-0.7					○																			
	<b>SNMM190616</b>	1.6	0.5-10.5	0.2-1.0					○																			
	<b>SNMM250924</b>	2.4	2.0-12.5	0.3-1.2					●																			

● Ex stock ○ On demand  
YBC152F, YBC252F, YBM153F, YBM253F available

HC<sup>1</sup> Coated carbide  
HT Uncoated cermet  
HC<sup>2</sup> Coated cermet  
HW Uncoated carbide

Tool holder						
PSBNR/L	PSDNN	PSKNR/L	PSSNR/L	MSBNR/L	MSRNR/L	MSKNR/L
Kr: 75°	Kr: 45°	Kr: 75°	Kr: 45°	Kr: 75°	Kr: 75°	Kr: 75°
A242	A244	A245	A246	A256	A257	A258

System code > A48

Grade selection > A42

Technical info > A501

Cutting data > A366



**A**

Turning

- Ideal machining conditions
- ⊗ Normal machining conditions
- ⊗ Unfavourable machining conditions

SNUN	L	I.C	S
12 04	12.7	12.7	4.76
19 04	19.05	19.05	4.76

## Turning inserts

SN** negative insert				HC <sup>1</sup> (CVD)										HC <sup>1</sup> (PVD)		HT	HC <sup>2</sup>	HW												
	P	M	K	N	S	H	YBC103	YB6315	YBC152	YBC203	YBC252	YBC352	YBM153	YBM253	YBD102	YB7315	YBD152	YBD152C	YBG101	YBG102	YBG105	YBG205	YB9320	YPD201	YBS103	YNG151	YNT251	YNG151C	YD101	YD201
	ISO	r	a <sub>p</sub>	f																										
	Flat	SNUN120408	0.8	0.7-6.0	0.2-0.5																									
		SNUN120412	1.2	0.7-6.0	0.25-0.60																									
		SNUN190412	1.2	0.9-6.0	0.25-0.60																									

● Ex stock    ○ On demand

HC<sup>1</sup> Coated carbide  
 HT Uncoated cermet  
 HC<sup>2</sup> Coated cermet  
 HW Uncoated carbide

**B**

Milling

**C**

Drilling

Tool holder		
CSKNR/L	CSRNR/L	CSDNN
Kr: 75°	Kr: 75°	Kr: 45°
A296	A297	A299

**D**

Technical Information

**E**

Index



- Ideal machining conditions
- Normal machining conditions
- Unfavourable machining conditions

TN**	L	I.C	S	d
16 04	16.5	9.525	4.76	3.81
22 04	22	12.7	4.76	5.16

**Turning inserts**

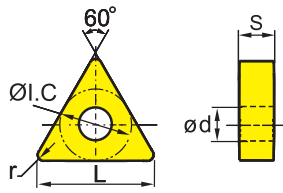

TN** negative insert				HC <sup>1</sup> (CVD)								HC <sup>1</sup> (PVD)				HT	HC <sup>2</sup>	HW										
				P	M	K	N	S	H																			
ISO	r	a <sub>p</sub>	f	YBC103	YB6315	YBC152	YBC203	YBC252	YBC352	YBM153	YBM253	YBD102	YB7315	YBD152	YBD152C	YBG101	YBG102	YBG105	YBG205	YB9320	YPD201	YBS103	YNG151	YNT251	YNG151C	YD101	YD201	
WG  Wiper	<b>TNMX160408-WG</b>	0.8	0.5-5.0	0.15-0.70	●																							
	<b>TNMX160412-WG</b>	1.2	0.8-6.0	0.20-0.75	○																							
ADF  Finishing	<b>TNMG160404-ADF</b>	0.4	0.5-5.0	0.05-0.30	●																							
	<b>TNMG160408-ADF</b>	0.8	0.5-5.0	0.1-0.4	●																							
	<b>TNMG160412-ADF</b>	1.2	0.5-5.0	0.2-0.5	●																							
DF  Finishing	<b>TNMG160404-DF</b>	0.4	0.15-2.00	0.08-0.25	●	●																						
	<b>TNMG160408-DF</b>	0.8	0.15-2.00	0.1-0.3	●	●																						
	<b>TNMG160412-DF</b>	1.2	0.35-1.50	0.15-0.50	●	●																						
	<b>TNMG220408-DF</b>	0.8	0.3-1.5	0.1-0.4	●	●																						
	<b>TNMG220412-DF</b>	1.2	0.35-1.50	0.15-0.50	●	●																						

● Ex stock ○ On demand  
YBC152F, YBC252F, YBM153F, YBM253F available

HC<sup>1</sup> Coated carbide  
HT Uncoated cermet  
HC<sup>2</sup> Coated cermet  
HW Uncoated carbide

Tool holder						
DTGNR/L	PTFNR/L	PTTNR/L	PTGNR/L	MTGNR/L	MTJNR/L	MTJNR/L
Kr: 91°	Kr: 91°	Kr: 60°	Kr: 90°	Kr: 90°	Kr: 93°	Kr: 93°
A233	A247	A248	A249	A260	A261	A262
MTFNR/L	S***-PTFNR/L					
Kr: 91°	Kr: 90°					
A263	A330					

System code > A48

Grade selection > A42

Technical info > A501

Cutting data > A366



A

Turning

B

Milling

C

Drilling

D

Technical Information

E

Index



**A**

Turning

- Ideal machining conditions
- ⊗ Normal machining conditions
- ⊗ Unfavourable machining conditions

TNMG	L	I.C	S	d
16 04	16.5	9.525	4.76	3.81

## Turning inserts

TN** negative insert				HC <sup>1</sup> (CVD)										HC <sup>1</sup> (PVD)		HT	HC <sup>2</sup>	HW										
	<b>P</b>	●●●●●	⊗⊗⊗												●	⊗	●											
	<b>M</b>			●	⊗										●	⊗	●											
	<b>K</b>																											
	<b>N</b>												●	●				●	⊗									
	<b>S</b>														●	⊗	●		●	⊗								
	<b>H</b>																											
	ISO	r	a <sub>p</sub>	f	YBC103	YB6315	YBC152	YBC203	YBC252	YBC352	YBM153	YBM253	YBD102	YB7315	YBD152	YBD152C	YBG101	YBG102	YBG105	YBG205	YB9320	YPD201	YBS103	YNG151	YNT251	YNG151C	YD101	YD201
SF	<b>TNMG160404-SF</b>	0.4	0.05-1.00	0.05-0.30																				○	●			
	<b>TNMG160408-SF</b>	0.8	0.05-1.00	0.05-0.40																						●		
Finishing																												

● Ex stock    ○ On demand

HC<sup>1</sup> Coated carbide  
 HT Uncoated cermet  
 HC<sup>2</sup> Coated cermet  
 HW Uncoated carbide

**B**

Milling

**C**

Drilling

**D**

Technical Information

**E**

Index

Tool holder						
<b>DTGNR/L</b> Kr: 91°	<b>PTFNR/L</b> Kr: 91°	<b>PTTNR/L</b> Kr: 60°	<b>PTGNR/L</b> Kr: 90°	<b>MTGNR/L</b> Kr: 90°	<b>MTJNR/L</b> Kr: 93°	<b>MTJNR/L</b> Kr: 93°
A233	A247	A248	A249	A260	A261	A262
<b>MTFNR/L</b> Kr: 91°	<b>S***-PTFNR/L</b> Kr: 90°					
A263	A330					

System code > A48

Grade selection > A42

Technical info > A501

Cutting data > A366

TNMG	L	I.C	S	d
11 03	11	6.35	3.18	2.26
16 04	16.5	9.525	4.76	3.81
22 04	22	12.7	4.76	5.16

- Ideal machining conditions
- Normal machining conditions
- Unfavourable machining conditions

**Turning inserts**

TN** negative insert				HC <sup>1</sup> (CVD)								HC <sup>1</sup> (PVD)			HT	HC <sup>2</sup>	HW													
	P	M	K	N	S	H																								
	ISO	r	a <sub>p</sub>	f	YBC103	YB6315	YBC152	YBC203	YBC252	YBC352	YBM153	YBM253	YBD102	YB7315	YBD152	YBD152C	YBG101	YBG102	YBG105	YBG205	YB9320	YPD201	YBS103	YNG151	YNT251	YNG151C	YD101	YD201		
		<b>TNMG110304-EF</b>	0.4	0.1-1.0	0.05-0.20															●										
		<b>TNMG110308-EF</b>	0.8	0.1-1.0	0.05-0.40															●										
		<b>TNMG160404-EF</b>	0.4	0.1-1.5	0.05-0.30							●								●										
		<b>TNMG160408-EF</b>	0.8	0.1-1.5	0.1-0.4							●								●										
<b>TNMG160412-EF</b>		1.2	0.2-2.5	0.15-0.40							○								●											
<b>TNMG220404-EF</b>		0.4	0.5-2.5	0.05-0.25							○								●											
<b>TNMG220408-EF</b>		0.8	0.5-2.5	0.1-0.4							○								●											

● Ex stock ○ On demand  
 YBC152F, YBC252F, YBM153F, YBM253F available

HC<sup>1</sup> Coated carbide  
 HT Uncoated cermet  
 HC<sup>2</sup> Coated cermet  
 HW Uncoated carbide

Tool holder						
DTGNR/L	PTFNR/L	PTTNR/L	PTGNR/L	MTGNR/L	MTJNR/L	MTJNR/L
Kr: 91°	Kr: 91°	Kr: 60°	Kr: 90°	Kr: 90°	Kr: 93°	Kr: 93°
A233	A247	A248	A249	A260	A261	A262
MTFNR/L	S***-PTFNR/L					
Kr: 91°	Kr: 90°					
A263	A330					

# General turning Negative inserts

**A**

Turning

- Ideal machining conditions
- ⊗ Normal machining conditions
- ⊗ Unfavourable machining conditions

TNMG	L	I.C	S	d
16 04	16,5	9.525	4.76	3.81
22 04	22	12.7	4.76	5.16

## Turning inserts

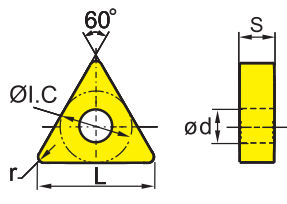

TN** negative insert				HC <sup>1</sup> (CVD)								HC <sup>1</sup> (PVD)		HT	HC <sup>2</sup>	HW														
				P	M	K	N	S	H																					
	ISO	r	a <sub>p</sub>	f	YBC103	YB6315	YBC152	YBC203	YBC252	YBC352	YBM153	YBM253	YBD102	YB7315	YBD152	YBD152C	YBG101	YBG102	YBG105	YBG205	YB9320	YPD201	YBS103	YNG151	YNT251	YNG151C	YD101	YD201		
FM 	<b>TNMG160404L-FM</b>	0.4	0.5-3.0	0.1-0.3						●										●										
	<b>TNMG160404R-FM</b>	0.4	0.5-3.0	0.1-0.3				○	●											●										
	<b>TNMG160408L-FM</b>	0.8	0.5-3.0	0.15-0.50				○	●											●										
	<b>TNMG160408R-FM</b>	0.8	0.5-3.0	0.15-0.50				●	●											●										
XM 	<b>TNMG160404-XM</b>	0.4	1-5.6	0.2-0.4	●				○																					
	<b>TNMG160408-XM</b>	0.8	1-5.6	0.2-0.4	●				●																					
	<b>TNMG160412-XM</b>	1.2	1-5.6	0.2-0.6	●				●																					
	<b>TNMG160416-XM</b>	1.6	1-5.6	0.2-0.65	○				●																					
	<b>TNMG220408-XM</b>	0.8	1-7.7	0.2-0.4	●				●																					
	<b>TNMG220412-XM</b>	1.2	1-7.7	0.2-0.6	●				●																					
<b>TNMG220416-XM</b>	1.6	1-7.7	0.2-0.65	○				●																						

● Ex stock   ○ On demand  
 YBC152F, YBC252F, YBM153F, YBM253F available

HC<sup>1</sup> Coated carbide  
 HT Uncoated cermet  
 HC<sup>2</sup> Coated cermet  
 HW Uncoated carbide

**B**

Milling

**C**

Drilling

**D**

Technical Information

**E**

Index

### Tool holder

DTGNR/L	PTFNR/L	PTTNR/L	PTGNR/L	MTGNR/L	MTJNR/L	MTJNR/L
Kr: 91°	Kr: 91°	Kr: 60°	Kr: 90°	Kr: 90°	Kr: 93°	Kr: 93°
A233	A247	A248	A249	A260	A261	A262
MTFNR/L	S***-PTFNR/L					
Kr: 91°	Kr: 90°					
A263	A330					





TNMG	L	I.C	S	d
11 03	11	6.35	3.18	2.26
16 04	16.5	9.525	4.76	3.81
22 04	22	12.7	4.76	5.16

- Ideal machining conditions
- ⊗ Normal machining conditions
- ⊗ Unfavourable machining conditions

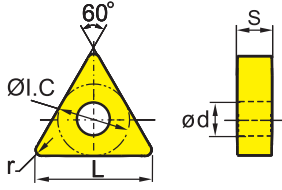
**Turning inserts**





TN** negative insert				HC <sup>1</sup> (CVD)								HC <sup>1</sup> (PVD)			HT	HC <sup>2</sup>	HW															
				P	M	K	N	S	H																							
ISO				r	a <sub>p</sub>	f	YBC103	YB6315	YBC152	YBC203	YBC252	YBC352	YBM153	YBM253	YBD102	YB7315	YBD152	YBD152C	YBG101	YBG102	YBG105	YBG205	YB9320	YPD201	YBS103	YNG151	YNT251	YNG151C	YD101	YD201		
DM  Medium Cut	TNMG110308-DM	0.8	0.3-3.0	0.1-0.4		○	●																									
	TNMG160404-DM	0.4	0.4-5.0	0.1-0.3		●	●		●																							
	TNMG160408-DM	0.8	0.5-5.0	0.15-0.50		●	●		○																							
	TNMG160412-DM	1.2	0.8-5.0	0.18-0.60		●	●																									
	TNMG220404-DM	0.4	0.4-6.6	0.1-0.3		●	●																									
	TNMG220408-DM	0.8	0.5-6.6	0.15-0.50		●	●																									
	TNMG220412-DM	1.2	0.8-6.6	0.18-0.60		●	●																									
TNMG220416-DM	1.6	1.0-6.6	0.23-0.65		●	●																										
PM  Medium Cut	TNMG110304-PM	0.4	0.4-3.0	0.1-0.3			●																									
	TNMG110308-PM	0.8	0.4-3.0	0.15-0.40			●																									
	TNMG160404-PM	0.4	0.4-5.0	0.1-0.3		●	●							●	●																	
	TNMG160408-PM	0.8	0.5-5.0	0.15-0.50		●	●							●	●																	
	TNMG160412-PM	1.2	0.8-5.0	0.18-0.60		●	●							○	○																	
	TNMG220408-PM	0.8	0.5-6.6	0.15-0.50		○	●							●	●																	
	TNMG220412-PM	1.2	0.8-6.6	0.18-0.60		○	●							●	●																	
TNMG220416-PM	1.6	1.0-6.6	0.23-0.65			○						○																				

● Ex stock ○ On demand  
YBC152F, YBC252F, YBM153F, YBM253F available

HC<sup>1</sup> Coated carbide  
HT Uncoated cermet  
HC<sup>2</sup> Coated cermet  
HW Uncoated carbide

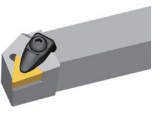
**Tool holder**

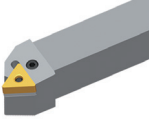
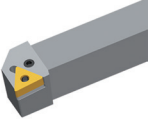
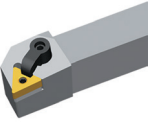
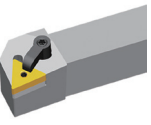
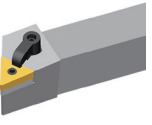
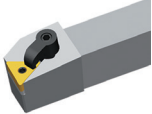
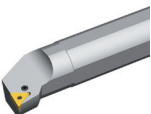
DTGNR/L	PTFNR/L	PTTNR/L	PTGNR/L	MTGNR/L	MTJNR/L	MTJNR/L
Kr: 91°	Kr: 91°	Kr: 60°	Kr: 90°	Kr: 90°	Kr: 93°	Kr: 93°
						
A233	A247	A248	A249	A260	A261	A262
MTFNR/L	S***-PTFNR/L					
Kr: 91°	Kr: 90°					
						
A263	A330					

System code > A48

Grade selection > A42

Technical info > A501

Cutting data > A366



A

Turning

B

Milling

C

Drilling

D

Technical Information

E

Index

**A**

Turning

- Ideal machining conditions
- ⊗ Normal machining conditions
- ⊗ Unfavourable machining conditions

TNMG	L	I.C	S	d
16 04	16.5	9.525	4.76	3.81

## Turning inserts

TN** negative insert					HC <sup>1</sup> (CVD)										HC <sup>1</sup> (PVD)		HT	HC <sup>2</sup>	HW										
					P	●	●	●	⊗	⊗	⊗																		
					M						●	⊗	●	●	⊗	⊗	⊗	●	⊗										
					K																								
					N											●	●					●	⊗						
					S																		●	⊗					
					H																								
ISO	r	a <sub>p</sub>	f		YBC103	YB6315	YBC152	YBC203	YBC252	YBC352	YBM153	YBM253	YBD102	YB7315	YBD152	YBD152C	YBG101	YBG102	YBG105	YBG205	YB9320	YPD201	YBS103	YNG151	YNT251	YNG151C	YD101	YD201	
ZM  Medium Cut	<b>TNMG160404-ZM</b>	0.4	0.5-5.0	0.08-0.30	●																								
	<b>TNMG160408-ZM</b>	0.8	0.5-5.0	0.1-0.4	●																								
	<b>TNMG160412-ZM</b>	1.2	0.5-5.0	0.1-0.6	●																								
SNR  Roughing	<b>TNMG160408-SNR</b>	0.8	1-5.6	0.1-0.5																				●					

● Ex stock    ○ On demand

HC<sup>1</sup> Coated carbide  
 HT Uncoated cermet  
 HC<sup>2</sup> Coated cermet  
 HW Uncoated carbide

**B**

Milling

**C**

Drilling

**D**



Technical Information

**E**

Index

Tool holder						
DTGNR/L	PTFNR/L	PTTNR/L	PTGNR/L	MTGNR/L	MTJNR/L	MTJNR/L
Kr: 91°	Kr: 91°	Kr: 60°	Kr: 90°	Kr: 90°	Kr: 93°	Kr: 93°
A233	A247	A248	A249	A260	A261	A262
MTFNR/L	S***-PTFNR/L					
Kr: 91°	Kr: 90°					
A263	A330					





-  Ideal machining conditions
-  Normal machining conditions
-  Unfavourable machining conditions

TNMG	L	I.C	S	d
16 04	16.5	9.525	4.76	3.81
22 04	22	12.7	4.76	5.16

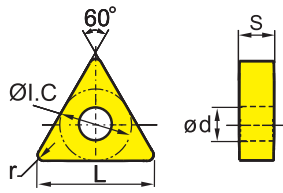
**Turning inserts**





TN** negative insert				HC <sup>1</sup> (CVD)								HC <sup>1</sup> (PVD)			HT	HC <sup>2</sup>	HW											
				P	M	K	N	S	H																			
ISO	r	a <sub>p</sub>	f	YBC103	YB6315	YBC152	YBC203	YBC252	YBC352	YBM153	YBM253	YBD102	YB7315	YBD152	YBD152C	YBG101	YBG102	YBG105	YBG205	YB9320	YPD201	YBS103	YNG151	YNT251	YNG151C	YD101	YD201	
EG  Medium Cut	<b>TNMG160404-EG</b>	0.4	0.5-4.0	0.1-0.3																								
	<b>TNMG160408-EG</b>	0.8	0.5-4.0	0.1-0.4																								
	<b>TNMG160412-EG</b>	1.2	0.5-4.0	0.15-0.50																								
EM  Medium Cut	<b>TNMG160404-EM</b>	0.4	0.5-4.8	0.05-0.30						●	○								●									
	<b>TNMG160408-EM</b>	0.8	0.5-4.8	0.10-0.45						●	●								●									
	<b>TNMG160412-EM</b>	1.2	0.5-4.8	0.1-0.6						●	●								●									
	<b>TNMG220408-EM</b>	0.8	0.5-6.6	0.10-0.45						●	●								●									
	<b>TNMG220412-EM</b>	1.2	0.5-6.6	0.1-0.6						○	●								●									
TC  Medium Cut	<b>TNMG160404-TC</b>	0.4	0.5-3.0	0.05-0.20								●		●														
	<b>TNMG160408-TC</b>	0.8	0.5-3.0	0.08-0.25								●		●														
	<b>TNMG160412-TC</b>	1.2	1-3	0.1-0.3								●		●														
	<b>TNMG220412-TC</b>	1.2	1-6	0.15-0.40								●		●														
	<b>TNMG220416-TC</b>	1.6	1-6	0.2-0.5								●		●														

● Ex stock ○ On demand  
YBC152F, YBC252F, YBM153F, YBM253F available

HC<sup>1</sup> Coated carbide  
HT Uncoated cermet  
HC<sup>2</sup> Coated cermet  
HW Uncoated carbide

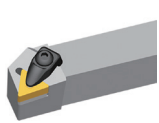
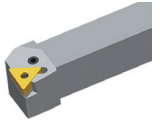
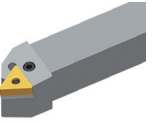
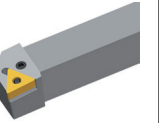
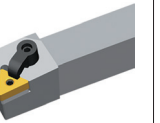
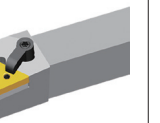
**Tool holder**

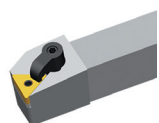
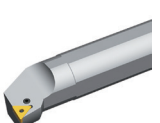
DTGNR/L	PTFNR/L	PTTNR/L	PTGNR/L	MTGNR/L	MTJNR/L	MTJNR/L
Kr: 91°	Kr: 91°	Kr: 60°	Kr: 90°	Kr: 90°	Kr: 93°	Kr: 93°
						
A233	A247	A248	A249	A260	A261	A262
MTFNR/L	S***-PTFNR/L					
Kr: 91°	Kr: 90°					
						
A263	A330					

System code > A48

Grade selection > A42

Technical info > A501

Cutting data > A366



**A** Turning  
**B** Milling  
**C** Drilling  
**D** Technical Information  
**E** Index

# General turning Negative inserts

**A**

Turning

**B**

Milling

**C**

Drilling

**D**

Technical Information

**E**

Index

- Ideal machining conditions
- ● Normal machining conditions
- ● ● Unfavourable machining conditions

TNMG	L	I.C	S	d
16 04	16.5	9.525	4.76	3.81
22 04	22	12.7	4.76	5.16
27 06	27.5	15.875	6.35	6.35

## Turning inserts

TN** negative insert				HC <sup>1</sup> (CVD)								HC <sup>1</sup> (PVD)			HT	HC <sup>2</sup>	HW															
	P	M	K	N	S	H	YBC103	YB6315	YBC152	YBC203	YBC252	YBC352	YBM153	YBM253	YBD102	YB7315	YBD152	YBD152C	YBG101	YBG102	YBG105	YBG205	YB9320	YPD201	YBS103	YNG151	YNT251	YNG151C	YD101	YD201		
	ISO	r	a <sub>p</sub>	f																												
		TNMG160408-DR	0.8	0.7-6.0	0.20-0.55	●	●									●	●															
		TNMG160412-DR	1.2	1-6	0.25-0.65	●	●									○		●														
		TNMG220408-DR	0.8	0.7-7.0	0.20-0.55														○													
		TNMG220412-DR	1.2	1-7	0.25-0.65															●												
TNMG220416-DR		1.6	1.5-7.0	0.32-0.75												○		●														
TNMG270608-DR		0.8	1.5-12.0	0.35-0.55																												
TNMG270612-DR		1.2	2-12	0.35-0.75														○														

● Ex stock   ○ On demand  
 YBC152F, YBC252F, YBM153F, YBM253F available

- HC<sup>1</sup> Coated carbide
- HT Uncoated cermet
- HC<sup>2</sup> Coated cermet
- HW Uncoated carbide

Tool holder						
DTGNR/L	PTFNR/L	PTTNR/L	PTGNR/L	MTGNR/L	MTJNR/L	MTJNR/L
Kr: 91°	Kr: 91°	Kr: 60°	Kr: 90°	Kr: 90°	Kr: 93°	Kr: 93°
A233	A247	A248	A249	A260	A261	A262
MTFNR/L	S***-PTFNR/L					
Kr: 91°	Kr: 90°					
A263	A330					



TN**	L	I.C	S	d
16 04	16.5	9.525	4.76	3.81
22 04	22	12.7	4.76	5.16
27 06	27.5	15.875	6.35	5.16

- Ideal machining conditions
- ⊗ Normal machining conditions
- ⊗ Unfavourable machining conditions

**Turning inserts**

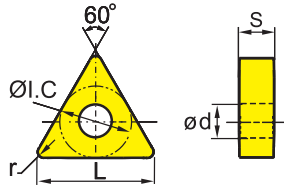

TN** negative insert				HC <sup>1</sup> (CVD)								HC <sup>1</sup> (PVD)		HT	HC <sup>2</sup>	HW																
				P	M	K	N	S	H																							
ISO				r	a <sub>p</sub>	f	YBC103	YB6315	YBC152	YBC203	YBC252	YBC352	YBM153	YBM253	YBD102	YBD152	YBD152C	YBG101	YBG102	YBG105	YBG205	YB9320	YPD201	YBS103	YNG151	YNT251	YNG151C	YD101	YD201			
 DR Roughing	TNMM160408-DR	0.8	0.7-6.0	0.20-0.55	○	●																										
	TNMM160412-DR	1.2	1-6	0.25-0.70	○																											
	TNMM220408-DR	0.8	0.7-8.0	0.20-0.55	○	○																										
	TNMM220412-DR	1.2	1-8	0.25-0.70			●																									
	TNMM220416-DR	1.6	1.5-8.0	0.32-0.90			○																									
	TNMM270612-DR	1.2	2.5-11.0	0.25-0.70			○																									
	TNMM270616-DR	1.6	2.5-11.0	0.3-0.9			○																									
 ER Roughing	TNMG160408-ER	0.8	2.0-5.6	0.15-0.55																												
	TNMG160412-ER	1.2	2.0-5.6	0.15-0.60																												
	TNMG220408-ER	0.8	2.0-7.7	0.15-0.55																												
	TNMG220412-ER	1.2	2.0-7.7	0.15-0.60																												
 LR Roughing	TNMM160408-LR	0.8	1-5	0.1-0.5	●	●	●																									
	TNMM160412-LR	1.2	1.5-6.0	0.1-0.6	○	○	○																									

● Ex stock ○ On demand  
 YBC152F, YBC252F, YBM153F, YBM253F available

HC<sup>1</sup> Coated carbide  
 HT Uncoated cermet  
 HC<sup>2</sup> Coated cermet  
 HW Uncoated carbide

**A**

Turning

**B**

Milling

**C**

Drilling

**D**

Technical Information

**E**

Index



**A**

Turning

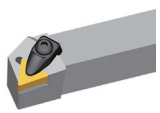
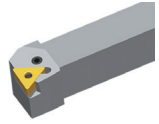
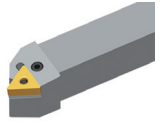
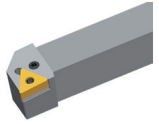
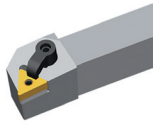
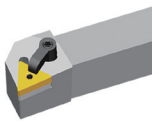
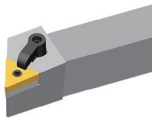
Tool holder						
DTG NR/L Kr: 91°	PTF NR/L Kr: 91°	PTT NR/L Kr: 60°	PTG NR/L Kr: 90°	MTG NR/L Kr: 90°	MTJ NR/L Kr: 93°	MTJ NR/L Kr: 93°
						
A233	A247	A248	A249	A260	A261	A262

**B**

Milling

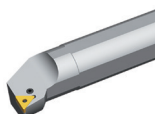
MTF NR/L Kr: 91°	S***-PTF NR/L Kr: 90°
	
A263	A330

**C**

Drilling

**D**

Technical Information

**E**

Index

System code > A48

Grade selection > A42

Technical info > A501

Cutting data > A366

- Ideal machining conditions
- Normal machining conditions
- Unfavourable machining conditions

TNMM	L	I.C	S	d
22 04	22	12.7	4.76	5.16
27 06	27.5	15.875	6.35	6.35

**Turning inserts**

TN** negative insert				HC <sup>1</sup> (CVD)								HC <sup>1</sup> (PVD)				HT	HC <sup>2</sup>	HW									
				<b>P</b>	●	●	●	●	●	●	●	●	●	●	●	●	●										
				<b>M</b>						●	●			●	●	●	●	●									
				<b>K</b>									●	●	●	●	●	●									
				<b>N</b>									●	●					●	●							
				<b>S</b>										●	●	●	●	●		●	●						
				<b>H</b>																							
ISO	r	a <sub>p</sub>	f	YBC103	YB6315	YBC152	YBC203	YBC252	YBC352	YBM153	YBM253	YBD102	YB7315	YBD152	YBD152C	YBG101	YBG102	YBG105	YBG205	YB9320	YPD201	YBS103	YNG151	YNT251	YNG151C	YD101	YD201
<b>HDR</b>	<b>TNMM220412-HDR</b>	1.2	2-9	0.25-0.80		○																					
 Heavy Turning	<b>TNMM220416-HDR</b>	1.6	2-9	0.35-1.00					○																		
	<b>TNMM270616-HDR</b>	1.6	2-6	0.35-1.00					●																		
	<b>TNMM270624-HDR</b>	2.4	2-7	0.4-1.2					●		○																

● Ex stock ○ On demand  
 YBC152F, YBC252F, YBM153F, YBM253F available

HC<sup>1</sup> Coated carbide  
 HT Uncoated cermet  
 HC<sup>2</sup> Coated cermet  
 HW Uncoated carbide

Tool holder						
PTFNR/L	PTTNR/L	PTGNR/L	MTGNR/L	MTJNR/L	MTJNR/L	MTFNR/L
Kr: 91°	Kr: 60°	Kr: 90°	Kr: 90°	Kr: 93°	Kr: 93°	Kr: 91°
A247	A248	A249	A260	A261	A262	A263

**A**

Turning

**B**

Milling

**C**

Drilling

**D**

Technical Information

**E**

Index

TNMG	L	I.C	S	d
16 04	16.5	9.525	4.76	3.81
22 04	22	12.7	4.76	5.16
27 06	27.5	15.875	6.35	6.35
33 09	33	19.05	9.525	7.94

- Ideal machining conditions
- Normal machining conditions
- Unfavourable machining conditions

## Turning inserts

TN** negative insert					HC <sup>1</sup> (CVD)								HC <sup>1</sup> (PVD)		HT	HC <sup>2</sup>	HW													
					P	●	●	●	●	●	●	●	●	●	●	●	●	●												
					M	●	●	●	●	●	●	●	●	●	●	●	●	●	●	●										
					K	●	●	●	●	●	●	●	●	●	●	●	●													
					N	●	●	●	●	●	●	●	●	●	●	●	●	●	●	●										
					S	●	●	●	●	●	●	●	●	●	●	●	●													
					H	●	●	●	●	●	●	●	●	●	●	●	●	●	●	●										
ISO		r	a <sub>p</sub>	f	YBC103	YB6315	YBC152	YBC203	YBC252	YBC352	YBM153	YBM253	YBD102	YB7315	YBD152	YBD152C	YBG101	YBG102	YBG105	YBG205	YB9320	YPD201	YBS103	YNG151	YNT251	YNG151C	YD101	YD201		
Basic	TNMG160404	0.4	0.2-4.0	0.05-0.20						○																				
	TNMG160408	0.8	0.2-4.0	0.08-0.30			●	●																						
	TNMG160412	1.2	0.2-4.0	0.1-0.4			●																							
	TNMG220404	0.4	0.2-6.0	0.05-0.20							○																			
Medium Cut	TNMG220408	0.8	0.2-6.0	0.1-0.3																										
	TNMG220416	1.6	0.2-6.0	0.1-0.5						○																				
	TNMG270612	1.2	0.2-9.0	0.1-0.5						○																				
	TNMG270616	1.6	0.2-9.0	0.1-0.5						○																				
	TNMG330916	1.6	0.2-11.0	0.1-0.5						○																				
	TNMG330924	2.4	0.2-11.0	0.1-0.7						○																				

● Ex stock    ○ On demand  
 YBC152F, YBC252F, YBM153F, YBM253F available

HC<sup>1</sup> Coated carbide  
 HT Uncoated cermet  
 HC<sup>2</sup> Coated cermet  
 HW Uncoated carbide

Tool holder						
DTGNR/L	PTFNR/L	PTTNR/L	PTGNR/L	MTGNR/L	MTJNR/L	MTJNR/L
Kr: 91°	Kr: 91°	Kr: 60°	Kr: 90°	Kr: 90°	Kr: 93°	Kr: 93°
A233	A247	A248	A249	A260	A261	A262
MTFNR/L	S***-PTFNR/L					
Kr: 91°	Kr: 90°					
A263	A330					



TN**	L	I.C	S	d
16 04	16.5	9.525	4.76	3.81
22 04	22	12.7	4.76	5.16
27 06	27.5	15.875	6.35	6.35

- Ideal machining conditions
- Normal machining conditions
- Unfavourable machining conditions

**Turning inserts**

TN** negative insert				HC <sup>1</sup> (CVD)								HC <sup>1</sup> (PVD)			HT	HC <sup>2</sup>	HW										
	<b>P</b>	●●●●●●●●	●●●●●●●●										●●●●	●●●●	●●●●												
	<b>M</b>			●●●●●●●●									●●●●●●●●	●●●●●●●●	●●●●●●●●												
	<b>K</b>				●●●●●●●●																						
	<b>N</b>											●●●●				●●●●											
	<b>S</b>												●●●●●●●●			●●●●											
	<b>H</b>																										
ISO	r	a <sub>p</sub>	f	YBC103	YB6315	YBC152	YBC203	YBC252	YBC352	YBM153	YBM253	YBD102	YB7315	YBD152	YBD152C	YBG101	YBG102	YBG105	YBG205	YB9320	YPD201	YBS103	YNG151	YNT251	YNG151C	YD101	YD201
	<b>TNMA160404</b>	0.4	0.2-4.0	0.05-0.20								○		●													
	<b>TNMA160408</b>	0.8	0.2-4.0	0.08-0.30								●	●	●													
	<b>TNMA160412</b>	1.2	0.2-4.0	0.1-0.4								○		●													
	<b>TNMA160416</b>	1.6	0.5-4.0	0.05-0.50								○	○														
	<b>TNMA220404</b>	0.4	0.2-6.0	0.05-0.20										●													
	<b>TNMA220408</b>	0.8	0.2-6.0	0.1-0.3									●	●													
	<b>TNMA220412</b>	1.2	0.2-6.0	0.1-0.4										●	●												
	<b>TNMA220416</b>	1.6	0.2-6.0	0.1-0.5											○												
	<b>TNMM160404</b>	0.4	0.2-7.0	0.05-0.60				○																			
	<b>TNMM160408</b>	0.8	0.5-7.0	0.05-0.60				○																			
	<b>TNMM220408</b>	0.8	0.5-7.0	0.05-0.60				○																			
	<b>TNMM220412</b>	1.2	1-7	0.1-0.6																							
	<b>TNMM220416</b>	1.6	0.5-7.0	0.05-0.60					○																		
	<b>TNMM270616</b>	1.6	0.5-6.5	0.05-0.70					○																		

● Ex stock ○ On demand  
 YBC152F, YBC252F, YBM153F, YBM253F available

HC<sup>1</sup> Coated carbide  
 HT Uncoated cermet  
 HC<sup>2</sup> Coated cermet  
 HW Uncoated carbide

Tool holder						
<b>DTGNR/L</b> Kr: 91°	<b>PTFNR/L</b> Kr: 91°	<b>PTTNR/L</b> Kr: 60°	<b>PTGNR/L</b> Kr: 90°	<b>MTGNR/L</b> Kr: 90°	<b>MTJNR/L</b> Kr: 93°	<b>MTJNR/L</b> Kr: 93°
A233	A247	A248	A249	A260	A261	A262
<b>MTFNR/L</b> Kr: 91°	<b>S***-PTFNR/L</b> Kr: 90°					
A263	A330					

# General turning Negative inserts

A

Turning

- Ideal machining conditions
- ⊗ Normal machining conditions
- ⊗ Unfavourable machining conditions

VN**	L	I.C	S	d
16 04	16.6	9.525	4.76	3.81

## Turning inserts

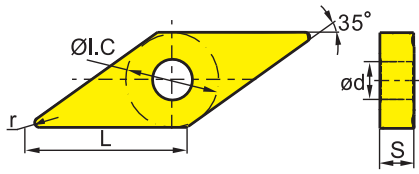

VN** negative insert					HC <sup>1</sup> (CVD)										HC <sup>1</sup> (PVD)			HT	HC <sup>2</sup>	HW			
					P	●	●	●	⊗	⊗	⊗					●	⊗	●					
					M					●	⊗												
					K					●	⊗	⊗	⊗										
					N									●	●					●	⊗		
					S											●	●				●	⊗	
					H																		
ISO					r	a <sub>p</sub>	f																
ADF	VNMG160404-ADF	0.4	0.5-2.5	0.1-0.3		●																	
	VNMG160408-ADF	0.8	0.5-2.5	0.1-0.5		●																	
Finishing																							
DF	VNMG160404-DF	0.4	0.25-1.50	0.07-0.30			○	●															
	VNMG160408-DF	0.8	0.3-1.5	0.1-0.4			●	●															
Finishing																							
EF	VNMG160404-EF	0.4	0.1-1.5	0.05-0.25					●								●						
	VNMG160408-EF	0.8	0.2-2.5	0.08-0.35					●								●						
	VNMG160412-EF	1.2	0.2-2.5	0.10-0.45						○													
Finishing																							
NF	VNEG160404-NF	0.4	0.2-4.0	0.05-0.30													●					○	
	VNEG160408-NF	0.8	0.2-4.0	0.05-0.50													●					○	
Finishing																							

● Ex stock ○ On demand  
 YBC152F, YBC252F, YBM153F, YBM253F available

HC<sup>1</sup> Coated carbide  
 HT Uncoated cermet  
 HC<sup>2</sup> Coated cermet  
 HW Uncoated carbide

B

Milling

C

Drilling

D

Technical Information

E

Index

Tool holder			
DVVNN	DVJNR/L	MVVNN	MVJNR/L
Kr: 72°30'	Kr: 93°	Kr: 72°30'	Kr: 93°
A234	A235	A264	A265

- Ideal machining conditions
- Normal machining conditions
- Unfavourable machining conditions

VN**	L	I.C	S	d
16 04	16.6	9.525	4.76	3.81

**Turning inserts**

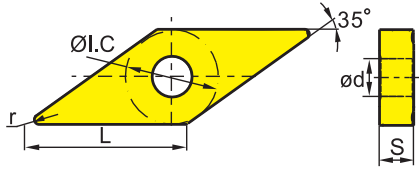

VN** negative insert				HC <sup>1</sup> (CVD)								HC <sup>1</sup> (PVD)			HT	HC <sup>2</sup>	HW										
				P	M	K	N	S	H																		
ISO	r	a <sub>p</sub>	f	YBC103	YB6315	YBC152	YBC203	YBC252	YBC352	YBM153	YBM253	YBD102	YB7315	YBD152	YBD152C	YBG101	YBG102	YBG105	YBG205	YB9320	YPD201	YBS103	YNG151	YNT251	YNG151C	YD101	YD201
NGF	<b>VNEG160408-NGF</b>	0.8	0.2-3.0	0.1-0.3														●									
	<b>VNEG160412-NGF</b>	1.2	0.2-3.0	0.1-0.5														○									
Finishing																											
SF	<b>VNMG160404-SF</b>	0.4	0.05-3.00	0.05-0.20																					●		
	<b>VNMG160408-SF</b>	0.8	0.05-3.00	0.05-0.35																					○		
Finishing																											

● Ex stock    ○ On demand

HC<sup>1</sup> Coated carbide  
 HT Uncoated cermet  
 HC<sup>2</sup> Coated cermet  
 HW Uncoated carbide

**Tool holder**

DVVNN	DVJNR/L	MVVNN	MVJNR/L
Kr: 72°30'	Kr: 93°	Kr: 72°30'	Kr: 93°
A234	A235	A264	A265

System code > A48

Grade selection > A42

Technical info > A501

Cutting data > A366



# General turning Negative inserts

**A**

Turning

- Ideal machining conditions
- ⊗ Normal machining conditions
- ⊗ Unfavourable machining conditions

VNMG	L	I.C	S	d
16 04	16.6	9.525	4.76	3.81

## Turning inserts

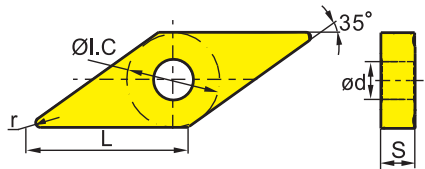

VN** negative insert				HC <sup>1</sup> (CVD)								HC <sup>1</sup> (PVD)		HT	HC <sup>2</sup>	HW															
				P	M	K	N	S	H																						
ISO				r	a <sub>p</sub>	f	YBC103	YB6315	YBC152	YBC203	YBC252	YBC352	YBM153	YBM253	YBD102	YB7315	YBD152	YBD152C	YBG101	YBG102	YBG105	YBG205	YB9320	YPD201	YBS103	YNG151	YNT251	YNG151C	YD101	YD201	
XF	VNMG160404-XF	0.4	0.5-2.5	0.1-0.25	●																										
	VNMG160408-XF	0.8	0.5-2.5	0.1-0.30	●																										
	VNMG160412-XF	1.2	0.5-2.5	0.1-0.35	●																										
Finishing																															
XM	VNMG160404-XM	0.4	1-5.6	0.2-0.4	●	○																									
	VNMG160408-XM	0.8	1-5.6	0.2-0.4	●	●																									
	VNMG160412-XM	1.2	1-5.6	0.2-0.6	●	●																									
	VNMG160416-XM	1.6	1-5.6	0.2-0.65	○	○																									

● Ex stock    ○ On demand

HC<sup>1</sup> Coated carbide  
 HT Uncoated cermet  
 HC<sup>2</sup> Coated cermet  
 HW Uncoated carbide

**B**

Milling

**C**

Drilling

**D**

Technical Information

**E**

Index

### Tool holder

DVNN	DVJNR/L	MVNN	MVJNR/L
Kr: 72°30'	Kr: 93°	Kr: 72°30'	Kr: 93°
A234	A235	A264	A265

System code > A48

Grade selection > A42

Technical info > A501

Cutting data > A366

- Ideal machining conditions
- Normal machining conditions
- Unfavourable machining conditions

VNMG	L	I.C	S	d
16 04	16.6	9.525	4.76	3.81

**Turning inserts**

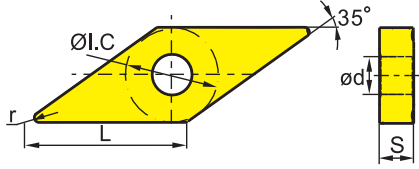

VN** negative insert				HC <sup>1</sup> (CVD)								HC <sup>1</sup> (PVD)				HT	HC <sup>2</sup>	HW											
				P	●	●	●	●	●	●	●	●	●	●	●	●	●	●											
				M	●	●	●	●	●	●	●	●	●	●	●	●	●	●											
				K	●	●	●	●	●	●	●	●	●	●	●	●	●	●											
				N	●	●	●	●	●	●	●	●	●	●	●	●	●	●											
				S	●	●	●	●	●	●	●	●	●	●	●	●	●	●											
				H	●	●	●	●	●	●	●	●	●	●	●	●	●	●											
ISO	r	a <sub>p</sub>	f	YBC103	YB6315	YBC152	YBC203	YBC252	YBC352	YBM153	YBM253	YBD102	YB7315	YBD152	YBD152C	YBG101	YBG102	YBG105	YBG205	YB9320	YPD201	YBS103	YNG151	YNT251	YNG151C	YD101	YD201		
Basic 	<b>VNMG160404</b>	0.4	0.2-6.0	0.05-0.60	○																								
	<b>VNMG160408</b>	0.8	0.2-6.0	0.08-0.60	○																								
Medium Cut																													
DM 	<b>VNMG160408-DM</b>	0.8	0.5-4.0	0.15-0.50	●	●																							
	<b>VNMG160412-DM</b>	1.2	0.8-4.0	0.18-0.60	●	●																							
Medium Cut																													
EM 	<b>VNMG160404-EM</b>	0.4	0.2-3.0	0.05-0.30						●									●										
	<b>VNMG160408-EM</b>	0.8	0.5-4.0	0.10-0.45						●									●										
Medium Cut																													
NM 	<b>VNMG160412-NM</b>	1.2	0.2-4.0	0.05-0.40														●											
Medium Cut																													

● Ex stock ○ On demand  
YBC152F, YBC252F, YBM153F, YBM253F available

HC<sup>1</sup> Coated carbide  
HT Uncoated cermet  
HC<sup>2</sup> Coated cermet  
HW Uncoated carbide

Tool holder			
DVVNN	DVJNR/L	MVVNN	MVJNR/L
Kr: 72°30'	Kr: 93°	Kr: 72°30'	Kr: 93°
A234	A235	A264	A265



A

Turning

B

Milling

C

Drilling

D

Technical Information

E

Index



**A**

Turning

- Ideal machining conditions
- ⊗ Normal machining conditions
- ⊗ Unfavourable machining conditions

VNMG	L	I.C	S	d
16 04	16.6	9.525	4.76	3.81

## Turning inserts

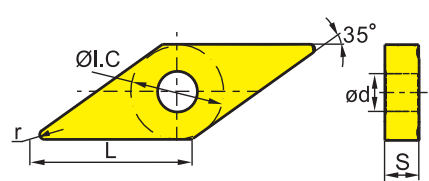

VN** negative insert					HC <sup>1</sup> (CVD)								HC <sup>1</sup> (PVD)			HT	HC <sup>2</sup>	HW												
					P	●	●	●	⊗	⊗	⊗																			
					M				●	⊗		●	●	⊗	⊗															
					K																									
					N							●	●			●														
					S											●														
					H																									
	ISO	r	a <sub>p</sub>	f	YBC103	YB6315	YBC152	YBC203	YBC252	YBC352	YBM153	YBM253	YBD102	YB7315	YBD152	YBD152C	YBG101	YBG102	YBG105	YBG205	YB9320	YPD201	YBS103	YNG151	YNT251	YNG151C	YD101	YD201		
PM 	VNMG160404-PM	0.4	0.4-4.0	0.13-0.40			●	●					●	○																
	VNMG160408-PM	0.8	0.5-4.0	0.15-0.50			●	●					●	●																
	VNMG160412-PM	1.2	0.8-4.0	0.18-0.60					●				●																	
TC 	VNMG160404-TC	0.4	0.5-2.0	0.05-0.20											●	●														
	VNMG160408-TC	0.8	0.5-2.0	0.08-0.25											●	●														
	VNMG160412-TC	1.2	0.5-3.0	0.08-0.30											●	●														
ZM 	VNMG160404-ZM	0.4	0.5-3.0	0.08-0.30	○																									
	VNMG160408-ZM	0.8	0.5-3.0	0.1-0.4	●																									
SNR 	VNMG160408-SNR	0.8	0.2-2.0	0.1-0.4														●		○	●									
	VNMG160412-SNR	1.2	0.2-2.0	0.1-0.5															●		○	●								

● Ex stock   ○ On demand  
 YBC152F, YBC252F, YBM153F, YBM253F available

HC<sup>1</sup> Coated carbide  
 HT Uncoated cermet  
 HC<sup>2</sup> Coated cermet  
 HW Uncoated carbide

**B**

Milling

**C**

Drilling

**D**

Technical Information

**E**

Index

Tool holder			
DVVNN	DVJNR/L	MVVNN	MVJNR/L
Kr: 72°30'	Kr: 93°	Kr: 72°30'	Kr: 93°
A234	A235	A264	A265



WNMG	L	I.C	S	d
06 T3	6.5	9.525	3.97	3.81
06 04	6.5	9.525	4.76	3.81
08 04	8.7	12.7	4.76	5.16

- Ideal machining conditions
- ⊗ Normal machining conditions
- ⊗ Unfavourable machining conditions

**Turning inserts**

WN** negative insert				HC <sup>1</sup> (CVD)								HC <sup>1</sup> (PVD)			HT	HC <sup>2</sup>	HW						
				P	M	K	N	S	H														
ADF	<b>WNMG080404-ADF</b>	0.4	0.2-2.5	0.05-0.30	●	●	●	●	●	●	●	●	●	●	●	●	●						
	<b>WNMG080408-ADF</b>	0.8	0.5-2.5	0.05-0.40	●	●	●	●	●	●	●	●	●	●	●	●	●						
	<b>WNMG080412-ADF</b>	1.2	0.5-2.5	0.05-0.50	●	●	●	●	●	●	●	●	●	●	●	●	●						
DF	<b>WNMG060404-DF</b>	0.4	0.15-2.00	0.08-0.25	●	●																	
	<b>WNMG060408-DF</b>	0.8	0.15-2.00	0.1-0.3	●	●																	
	<b>WNMG080404-DF</b>	0.4	0.15-2.00	0.08-0.25	●	●																	
	<b>WNMG080408-DF</b>	0.8	0.15-2.00	0.1-0.3	●	●	○																
	<b>WNMG080412-DF</b>	1.2	0.2-2.5	0.10-0.35	●	●																	
SF	<b>WNMG060404-SF</b>	0.4	0.05-0.50	0.05-0.20														●					
	<b>WNMG060408-SF</b>	0.8	0.05-0.50	0.05-0.35														●					
	<b>WNMG06T304-SF</b>	0.4	0.05-0.50	0.05-0.20														●					
	<b>WNMG06T308-SF</b>	0.8	0.05-0.50	0.05-0.35														●					
	<b>WNMG080404-SF</b>	0.4	0.05-0.50	0.05-0.20														●					
<b>WNMG080408-SF</b>	0.8	0.05-0.50	0.05-0.35														●						

● Ex stock    ○ On demand  
 YBC152F, YBC252F, YBM153F, YBM253F available

HC<sup>1</sup> Coated carbide  
 HT Uncoated cermet  
 HC<sup>2</sup> Coated cermet  
 HW Uncoated carbide

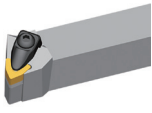
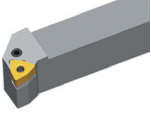
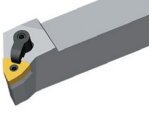
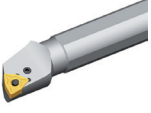
Tool holder			
DWLNLR/L	PWLNLR/L	MWLNLR/L	S***-PWLNLR/L
Kr: 95°	Kr: 95°	Kr: 95°	Kr: 95°
			
A236	A251	A266	A332

# General turning Negative inserts

A

Turning

B

Milling

C

Drilling

D

Technical Information

E

Index

- Ideal machining conditions
- ⊗ Normal machining conditions
- ⊗ Unfavourable machining conditions

WN**	L	I.C	S	d
06 T3	6.5	9.525	3.97	3.81
06 04	6.5	9.525	4.76	3.81
08 04	8.7	12.7	4.76	5.16

## Turning inserts

WN** negative insert				HC <sup>1</sup> (CVD)								HC <sup>1</sup> (PVD)			HT	HC <sup>2</sup>	HW												
				P	●	●	●	⊗	⊗	⊗					●	⊗	●												
				M					●	⊗		●	●	⊗	⊗	●	⊗	●											
				K								●	⊗	⊗	⊗														
				N										●	●				●	⊗									
				S												●	●	⊗	⊗	●									
				H																									
ISO	r	a <sub>p</sub>	f	YBC103	YB6315	YBC152	YBC203	YBC252	YBC352	YBM153	YBM253	YBD102	YB7315	YBD152	YBD152C	YBG101	YBG102	YBG105	YBG205	YB9320	YPD201	YBS103	YNG151	YNT251	YNG151C	YD101	YD201		
WG  Wiper	<b>WNMG080408-WG</b>	0.8	0.5-5.0	0.15-0.70		●	●																						
	<b>WNMG080412-WG</b>	1.2	0.8-6.0	0.20-0.75		●	○																						
EF  Finishing	<b>WNMG060404-EF</b>	0.4	0.1-1.5	0.05-0.30															●										
	<b>WNMG060408-EF</b>	0.8	0.1-1.5	0.1-0.4															●										
	<b>WNMG06T308-EF</b>	0.8	0.1-1.5	0.1-0.4															●										
	<b>WNMG080404-EF</b>	0.4	0.1-1.5	0.05-0.30							●								●										
	<b>WNMG080408-EF</b>	0.8	0.1-1.5	0.1-0.4							●								○	●									
NF  Finishing	<b>WNEG080404-NF</b>	0.4	0.2-3.0	0.05-0.30														○	●										
	<b>WNEG080408-NF</b>	0.8	0.2-2.5	0.05-0.30															●										
NF  Finishing	<b>WNMG060408-NF</b>	0.8	0.2-2.5	0.05-0.30														●											

● Ex stock   ○ On demand  
 YBC152F, YBC252F, YBM153F, YBM253F available

HC<sup>1</sup> Coated carbide  
 HT Uncoated cermet  
 HC<sup>2</sup> Coated cermet  
 HW Uncoated carbide

Tool holder			
DWLNRL	PWLNRL	MWLNRL	S***-PWLNRL
Kr: 95°	Kr: 95°	Kr: 95°	Kr: 95°
A236	A251	A266	A332



- Ideal machining conditions
- Normal machining conditions
- Unfavourable machining conditions

WNMG	L	I.C	S	d
<b>06 04</b>	6.5	9.525	4.76	3.81
<b>08 04</b>	8.7	12.7	4.76	5.16

**Turning inserts**

WN** negative insert				HC <sup>1</sup> (CVD)								HC <sup>1</sup> (PVD)				HT	HC <sup>2</sup>	HW												
	<b>P</b>	●●●●●●●●●●												●●	●●															
	<b>M</b>					●●	●●	●●	●●	●●	●●	●●	●●																	
	<b>K</b>																													
	<b>N</b>										●●	●●					●●													
	<b>S</b>																●●													
	<b>H</b>																													
	ISO	r	a <sub>p</sub>	f	YBC103	YB6315	YBC152	YBC203	YBC252	YBC352	YBM153	YBM253	YBD102	YB7315	YBD152	YBD152C	YBG101	YBG102	YBG105	YBG205	YB9320	YPD201	YBS103	YNG151	YNT251	YNG151C	YD101	YD201		
<b>XF</b>  Finishing	<b>WNMG060404-XF</b>	0.4	0.5-2.0	0.1-0.25	●																									
	<b>WNMG060408-XF</b>	0.8	0.5-2.0	0.1-0.30	●																									
	<b>WNMG080408-XF</b>	0.8	0.5-2.5	0.1-0.30	●																									
	<b>WNMG080412-XF</b>	1.2	0.5-2.5	0.1-0.35	●																									
<b>XM</b>  Medium Cut	<b>WNMG060404-XM</b>	0.4	1-2.1	0.2-0.4	●	○																								
	<b>WNMG060408-XM</b>	0.8	1-2.1	0.2-0.4	●	●																								
	<b>WNMG060412-XM</b>	1.2	1-2.1	0.2-0.6	●	●																								
	<b>WNMG080404-XM</b>	0.4	1-2.8	0.2-0.4	●	●																								
	<b>WNMG080408-XM</b>	0.8	1-2.8	0.2-0.4	●	●																								
	<b>WNMG080412-XM</b>	1.2	1-2.8	0.2-0.6	●	●																								
<b>WNMG080416-XM</b>	1.6	1-2.8	0.2-0.65	○	○																									

● Ex stock ○ On demand

HC<sup>1</sup> Coated carbide  
 HT Uncoated cermet  
 HC<sup>2</sup> Coated cermet  
 HW Uncoated carbide

Tool holder			
<b>DWLNR/L</b>	<b>PWLNR/L</b>	<b>MWLNR/L</b>	<b>S***-PWLNR/L</b>
Kr: 95°	Kr: 95°	Kr: 95°	Kr: 95°
A236	A251	A266	A332

System code > A48

Grade selection > A42

Technical info > A501

Cutting data > A366



**A**

Turning

**B**

Milling

**C**

Drilling

**D**

Technical Information

**E**

Index

**A**

Turning

**B**

Milling

**C**

Drilling

**D**

Technical Information





**E**

Index

- Ideal machining conditions
- ⊗ Normal machining conditions
- ⊗ Unfavourable machining conditions

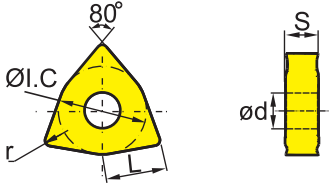

WNMG	L	I.C	S	d
<b>06 T3</b>	6.5	9.525	3.97	3.81
<b>06 04</b>	6.5	9.525	4.76	3.81
<b>08 04</b>	8.7	12.7	4.76	5.16

## Turning inserts

WN** negative insert				HC <sup>1</sup> (CVD)								HC <sup>1</sup> (PVD)			HT	HC <sup>2</sup>	HW														
	P	M	K	N	S	H	YBC103	YB6315	YBC152	YBC203	YBC252	YBC352	YBM153	YBM253	YBD102	YB7315	YBD152	YBD152C	YBG101	YBG102	YBG105	YBG205	YB9320	YPD201	YBS103	YNG151	YNT251	YNG151C	YD101	YD201	
	ISO	r	a <sub>p</sub>	f																											
	 DM Medium Cut	<b>WNMG060408-DM</b>	0.8	0.5-3.0	0.15-0.50																										
		<b>WNMG060412-DM</b>	1.2	0.8-3.0	0.18-0.60																										
		<b>WNMG06T308-DM</b>	0.8	0.5-3.0	0.15-0.15																										
<b>WNMG080404-DM</b>		0.4	0.5-4.0	0.1-0.4																											
<b>WNMG080408-DM</b>		0.8	0.5-4.0	0.15-0.50																											
<b>WNMG080412-DM</b>		1.2	0.8-4.0	0.18-0.60																											
<b>WNMG080416-DM</b>		1.6	1-4	0.23-0.65																											
 EG Medium Cut	<b>WNMG080408-EG</b>	0.8	0.5-4.0	0.05-0.40																											
	<b>WNMG080412-EG</b>	1.2	0.5-4.0	0.05-0.60																											
 EM Medium Cut	<b>WNMG060404-EM</b>	0.4	0.5-3.0	0.05-0.30																											
	<b>WNMG060408-EM</b>	0.8	0.5-3.0	0.1-0.5																											
	<b>WNMG06T304-EM</b>	0.4	0.5-3.0	0.05-0.30																											
	<b>WNMG06T308-EM</b>	0.8	0.5-3.0	0.1-0.5																											
	<b>WNMG06T312-EM</b>	1.2	0.5-3.0	0.1-0.7																											
	<b>WNMG080404-EM</b>	0.4	1-4	0.05-0.30																											
	<b>WNMG080408-EM</b>	0.8	1-4	0.1-0.5																											
<b>WNMG080412-EM</b>	1.2	1-4	0.1-0.7																												

● Ex stock    ○ On demand  
 YBC152F, YBC252F, YBM153F, YBM253F available

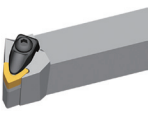
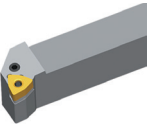
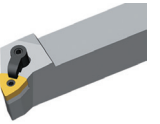
HC<sup>1</sup> Coated carbide  
 HT Uncoated cermet  
 HC<sup>2</sup> Coated cermet  
 HW Uncoated carbide

Tool holder			
DWLNRL/L	PWLNRL/L	MWLNRL/L	S***-PWLNRL/L
Kr: 95°	Kr: 95°	Kr: 95°	Kr: 95°
			
A236	A251	A266	A332



- Ideal machining conditions
- ⊗ Normal machining conditions
- ⊙ Unfavourable machining conditions

WNMG	L	I.C	S	d
06 04	6.5	9.525	4.76	3.81
08 04	8.7	12.7	4.76	5.16

## Turning inserts

WN** negative insert					HC <sup>1</sup> (CVD)								HC <sup>1</sup> (PVD)				HT	HC <sup>2</sup>	HW									
	<b>P</b>	●	●	●	●	●	●	●	●	●	●		●	●	●	●												
	<b>M</b>						●	●	●				●	●	●													
	<b>K</b>									●	●	●	●															
	<b>N</b>											●	●				●	●										
	<b>S</b>													●	●	●		●	●									
	<b>H</b>																											
ISO	r	a <sub>p</sub>	f	YBC103	YB6315	YBC152	YBC203	YBC252	YBC352	YBM153	YBM253	YBD102	YB7315	YBD152	YBD152C	YBG101	YBG102	YBG105	YBG205	YB9320	YPD201	YBS103	YNG151	YNT251	YNG151C	YD101	YD201	
<b>PM</b>  Medium Cut	WNMG060408-PM	0.8	0.5-3.0	0.15-0.50		●	●				●	●																
	WNMG060412-PM	1.2	0.8-3.0	0.18-0.60		●	○				○																	
	WNMG080404-PM	0.4	0.4-4.0	0.12-0.40		●	●					●	●															
	WNMG080408-PM	0.8	0.5-4.0	0.15-0.50		●	●	●				●	●															
	WNMG080412-PM	1.2	0.8-4.0	0.18-0.60		●	●					●	●															
	WNMG080416-PM	1.6	1-4	0.23-0.65				●				●	●															
<b>ZM</b>  Medium Cut	WNMG080408-ZM	0.8	0.5-4.0	0.1-0.5	●																							
	WNMG080412-ZM	1.2	1.0-5.5	0.15-0.60	●																							
<b>SNR</b>  Roughing	WNMG080408-SNR	0.8	1-3	0.1-0.5													○		●	○								
	WNMG080412-SNR	1.2	1-3	0.2-0.6																●								

● Ex stock ○ On demand  
 YBC152F, YBC252F, YBM153F, YBM253F available

HC<sup>1</sup> Coated carbide  
 HT Uncoated cermet  
 HC<sup>2</sup> Coated cermet  
 HW Uncoated carbide

Tool holder			
DWLNR/L	PWLNR/L	MWLNR/L	S***-PWLNR/L
Kr: 95°	Kr: 95°	Kr: 95°	Kr: 95°
A236	A251	A266	A332

System code > A48

Grade selection > A42

Technical info > A501

Cutting data > A366

# General turning Negative inserts

**A**

Turning

- Ideal machining conditions
- ⊗ Normal machining conditions
- ⊗ Unfavourable machining conditions

WNMG	L	I.C	S	d
08 04	8.7	12.7	4.76	5.16

## Turning inserts

WN** negative insert		HC <sup>1</sup> (CVD)						HC <sup>1</sup> (PVD)			HT	HC <sup>2</sup>	HW			
	<b>P</b>	●	●	●	⊗	⊗	⊗				●	⊗	●			
	<b>M</b>						●	⊗	●	●	⊗	⊗	⊗	●		
	<b>K</b>															
	<b>N</b>									●	●				●	⊗
	<b>S</b>														●	⊗
	<b>H</b>															

**B**

Milling

ISO		r	a <sub>p</sub>	f	YBC103	YB6315	YBC152	YBC203	YBC252	YBC352	YBM153	YBM253	YBD102	YB7315	YBD152	YBD152C	YBG101	YBG102	YBG105	YBG205	YB9320	YPD201	YBS103	YNG151	YNT251	YNG151C	YD101	YD201
 Medium Cut	<b>NM</b>																											
	<b>WNMG080404-NM</b>	0.4	0.2-3.0	0.05-0.30																●								
	<b>WNMG080408-NM</b>	0.8	0.2-3.0	0.1-0.3																●	●	○						
<b>WNMG080412-NM</b>	1.2	0.2-4.0	0.1-0.4																●	●								
 Medium Cut	<b>TC</b>																											
	<b>WNMG080404-TC</b>	0.4	0.5-3.0	0.08-0.25										●			○											
	<b>WNMG080408-TC</b>	0.8	0.5-4.0	0.15-0.40										●			●											
<b>WNMG080412-TC</b>	1.2	0.5-4.0	0.2-0.6										●			●												
 Medium Cut	<b>TK</b>																											
	<b>WNMG080408-TK</b>	0.8	0.2-0.4	0.2-0.4										●														
	<b>WNMG080412-TK</b>	1.2	0.2-0.4	0.2-0.45										○														
<b>WNMG080416-TK</b>	1.6	0.2-0.4	0.2-0.5										○															

● Ex stock    ○ On demand

- HC<sup>1</sup> Coated carbide
- HT Uncoated cermet
- HC<sup>2</sup> Coated cermet
- HW Uncoated carbide

**D**

Technical Information

Tool holder			
DWLNR/L	PWLNR/L	MWLNRL	S***-PWLNR/L
Kr: 95°	Kr: 95°	Kr: 95°	Kr: 95°
A236	A251	A266	A332

**F**

Index



WN**	L	I.C	S	d
06 T3	6.5	9.525	3.97	3.81
06 04	6.5	9.525	4.76	3.81
08 04	8.7	12.7	4.76	5.16

- Ideal machining conditions
- ⊗ Normal machining conditions
- ⊗ Unfavourable machining conditions

**Turning inserts**

WN** negative insert				HC <sup>1</sup> (CVD)								HC <sup>1</sup> (PVD)			HT	HC <sup>2</sup>	HW											
				P	M	K	N	S	H																			
ISO	r	a <sub>p</sub>	f	YBC103	YB6315	YBC152	YBC203	YBC252	YBC352	YBM153	YBM253	YBD102	YB7315	YBD152	YBD152C	YBG101	YBG102	YBG105	YBG205	YB9320	YPD201	YBS103	YNG151	YNT251	YNG151C	YD101	YD201	
<b>DR</b> 	<b>WNMG060408-DR</b>	0.8	0.7-3.5	0.20-0.45	●	●						●	●															
	<b>WNMG060412-DR</b>	1.2	0.8-3.5	0.25-0.55	●	●						○	○															
	<b>WNMG080408-DR</b>	0.8	0.7-5.0	0.20-0.55	●	●	●					●	●															
	<b>WNMG080412-DR</b>	1.2	1-5	0.25-0.70	○	●	●	●				●	●															
	<b>WNMG080416-DR</b>	1.6	1.5-5.0	0.32-0.75		○	●					●		○														
<b>Flat</b> 	<b>WNMA060408</b>	0.8	0.5-3.0	0.1-0.3								●	●															
	<b>WNMA060412</b>	1.2	0.5-3.0	0.15-0.30										●														
	<b>WNMA06T308</b>	0.8	0.5-3.0	0.1-0.3																								
	<b>WNMA080404</b>	0.4	0.5-4.0	0.08-0.25								○	●	○														
	<b>WNMA080408</b>	0.8	0.5-4.0	0.15-0.30								●	●	●														
	<b>WNMA080412</b>	1.2	0.5-5.0	0.15-0.30								●	○	●	●													
	<b>WNMA080416</b>	1.6	0.5-5.0	0.2-0.5								○	○	○														

● Ex stock ○ On demand  
YBC152F, YBC252F, YBM153F, YBM253F available

HC<sup>1</sup> Coated carbide  
HT Uncoated cermet  
HC<sup>2</sup> Coated cermet  
HW Uncoated carbide

Tool holder			
DWLNR/L	PWLNR/L	MWLNR/L	S***-PWLNR/L
Kr: 95°	Kr: 95°	Kr: 95°	Kr: 95°
A236	A251	A266	A332

System code > A48

Grade selection > A42

Technical info > A501

Cutting data > A366



**A** Turning  
**B** Milling  
**C** Drilling  
**D** Technical Information  
**E** Index



# General turning Negative inserts

**A**

Turning

- Ideal machining conditions
- ⊗ Normal machining conditions
- ⊛ Unfavourable machining conditions

RNMG	L	I.C	S	d
12 04	12.7	12.7	4.76	5.16

## Turning inserts

RN** negative insert			HC <sup>1</sup> (CVD)										HC <sup>1</sup> (PVD)			HT	HC <sup>2</sup>	HW								
	<b>P</b>	●●●●●●●●●●	●●●●●●●●●●	●●●●●●●●●●	●●●●●●●●●●	●●●●●●●●●●	●●●●●●●●●●	●●●●●●●●●●	●●●●●●●●●●	●●●●●●●●●●	●●●●●●●●●●	●●●●●●●●●●	●●●●●●●●●●	●●●●●●●●●●	●●●●●●●●●●	●●●●●●●●●●										
	<b>M</b>													●●●●●●●●●●	●●●●●●●●●●	●●●●●●●●●●										
	<b>K</b>																									
	<b>N</b>													●●●●●●●●●●	●●●●●●●●●●	●●●●●●●●●●										
	<b>S</b>																●●●●●●●●●●									
	<b>H</b>																									
ISO	a <sub>p</sub>	f	YBC103	YB6315	YBC152	YBC203	YBC252	YBC352	YBM153	YBM253	YBD102	YB7315	YBD152	YBD152C	YBG101	YBG102	YBG105	YBG205	YB9320	YPD201	YBS103	YNG151	YNT251	YNG151C	YD101	YD201
Basic	<b>RNMG120400</b>	0.5-7.0	0.1-1.8										○	○												
Medium Cut																										

● Ex stock    ○ On demand

HC<sup>1</sup> Coated carbide  
 HT Uncoated cermet  
 HC<sup>2</sup> Coated cermet  
 HW Uncoated carbide

**B**

Milling

**C**

Drilling

Tool holder	
MRDNN	MRGNR/L
A267	A268

**D**

Technical Information

**E**

Index

System code > A48

Grade selection > A42

Technical info > A501

Cutting data > A366

- Ideal machining conditions
- Normal machining conditions
- Unfavourable machining conditions

KNUX	L	I.W	S
16 04		9.525	4.76

**Turning inserts**

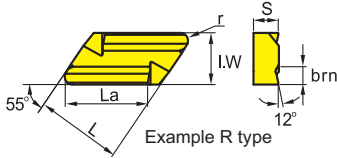

KN** negative insert							HC <sup>1</sup> (CVD)					HC <sup>1</sup> (PVD)			HT	HC <sup>2</sup>	HW																	
							P	M	K	N	S	H																						
 KNUX Finishing	ISO	La	brn	r	a <sub>p</sub>	f	YBC103	YB6315	YBC152	YBC203	YBC252	YBC352	YBM153	YBM253	YBD102	YB7315	YBD152	YBD152C	YBG101	YBG102	YBG105	YBG205	YB9320	YPD201	YBS103	YNG151	YNT251	YNG151C	YD101	YD201				
	KNUX160405L11	16	2.2	0.5	0.2-6.0	0.05-0.70						●																			○			
	KNUX160405L12	16	2.2	0.5	0.2-6.0	0.05-0.70																												
	KNUX160405R11	16	2.2	0.5	0.2-6.0	0.05-0.70						●																						
	KNUX160405R12	16	2.2	0.5	0.2-6.0	0.05-0.70																												
	KNUX160410L11	16	2.2	1	0.2-6.0	0.05-0.70																												
	KNUX160410L12	16	2.2	1	0.2-6.0	0.05-0.70			○																									
	KNUX160410R11	16	2.2	1	0.2-6.0	0.05-0.70						●																						
KNUX160410R12	16	2.2	1	0.2-6.0	0.05-0.70																													

● Ex stock ○ On demand  
 YBC152F, YBC252F, YBM153F, YBM253F available

HC<sup>1</sup> Coated carbide  
 HT Uncoated cermet  
 HC<sup>2</sup> Coated cermet  
 HW Uncoated carbide

Tool holder	
CKJNR/L	CKNNR/L
Kr: 93°	Kr: 63°
A290	A291

# General turning Negative inserts

**A**

Turning

- Ideal machining conditions
- ⊗ Normal machining conditions
- ⊗ Unfavourable machining conditions

CN**	L	I.C	S	d
19 07	19.3	19.05	7.94	7.93
19 11	19.3	19.05	11	7.8

## Turning inserts

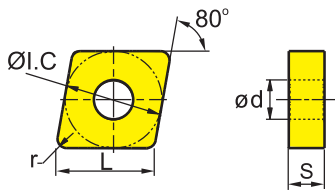

CN** negative insert				HC <sup>1</sup> (CVD)										HC <sup>1</sup> (PVD)		HT	HC <sup>2</sup>	HW															
				P	●	●	●	⊗	⊗	⊗																							
				M					●	⊗			●	●	⊗	⊗	●	●															
				K																													
				N								●	●						●	⊗													
				S										●	●	⊗	⊗			●	⊗												
				H																													
ISO				r	a <sub>p</sub>	f	YBC103	YB6315	YBC152	YBC203	YBC252	YBC352	YBM153	YBM253	YBD102	YB7315	YBD152	YBD152C	YBG101	YBG102	YBG105	YBG205	YB9320	YPD201	YBS103	YNG151	YNT251	YNG151C	YD101	YD201			
RF	<b>CNMG191140-RF</b>	4	1.0-5.5	0.20-0.60				●																									
Finishing																																	
RF	<b>CNMM190740-RF</b>	4	1.0-5.5	0.20-0.60				●																									
Finishing																																	
		<b>CNMM191140-RF</b>	4	1.0-5.5	0.20-0.60			●																									
RH	<b>CNMM190740-RH</b>	4	1.5-7.0	0.35-1.20				●	●																								
Roughing																																	
		<b>CNMM191140-RH</b>	4	1.5-7.0	0.35-1.20			●	●																								

● Ex stock    ○ On demand

HC<sup>1</sup> Coated carbide  
 HT Uncoated cermet  
 HC<sup>2</sup> Coated cermet  
 HW Uncoated carbide

**B**

Milling

**C**

Drilling

**D**

Technical Information

**E**

Index

Tool holder

**PCLNR/L**

Kr: 95°



A318

System code > A48

Grade selection > A42

Technical info > A501

Cutting data > A366



**Turning inserts**

- Ideal machining conditions
- Normal machining conditions
- Unfavourable machining conditions

LNUX	L	I.C	S	d
19 19	19.05	10	19.05	6.35
30 19	30	10	19.05	6.35

LN** negative insert				HC <sup>1</sup> (CVD)								HC <sup>1</sup> (PVD)			HT	HC <sup>2</sup>	HW										
				P	M	K	N	S	H																		
ISO	r	a <sub>p</sub>	f	YBC103	YB6315	YBC152	YBC203	YBC252	YBC352	YBM153	YBM253	YBD102	YB7315	YBD152	YBD152C	YBG101	YBG102	YBG105	YBG205	YB9320	YPD201	YBS103	YNG151	YNT251	YNG151C	YD101	YD201
RF  Heavy Turning	<b>LNUX191940-RF</b>	4	1,0-5,5	0,20-0,60	●	●																					
	<b>LNUX301940-RF</b>	4	1,0-6,0	0,20-0,70	●	○																					
RH  Heavy Turning	<b>LNUX191940-RH</b>	4	1,5-7,0	0,35-1,20	●	●																					
	<b>LNUX301940-RH</b>	4	1,5-8,0	0,35-1,40	●	●																					

● Ex stock ○ On demand

HC<sup>1</sup> Coated carbide  
 HT Uncoated cermet  
 HC<sup>2</sup> Coated cermet  
 HW Uncoated carbide

Tool holder	
<b>PLANR/L</b> Kr: 90°	<b>PLFNR/L</b> Kr: 90°
A316	A317

# General turning Positive inserts

**A**

Turning

- Ideal machining conditions
- ⊗ Normal machining conditions
- ⊗ Unfavourable machining conditions

CCGT	L	I.C	S	d
06 02	6.4	6.35	2.38	2.8
09 T3	9.7	9.525	3.97	4.4

## Turning inserts

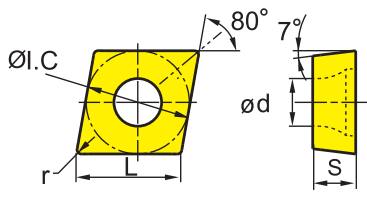

CC** positive insert				HC <sup>1</sup> (CVD)								HC <sup>1</sup> (PVD)		HT	HC <sup>2</sup>	HW													
				P	M	K	N	S	H																				
	ISO	r	a <sub>p</sub>	f	YBC103	YB6315	YBC152	YBC203	YBC252	YBC352	YBM153	YBM253	YBD102	YB7315	YBD152	YBD152C	YBG101	YBG102	YBG105	YBG205	YB9320	YPD201	YBS103	YNG151	YNT251	YNG151C	YD101	YD201	
SF	CCGT060202-SF	0.2	0.05-2.00	0.05-0.18																				●	●				
	CCGT060204-SF	0.4	0.05-2.00	0.05-0.35																					●	●	●		
	CCGT09T304-SF	0.4	0.05-2.00	0.05-0.35																					●	●	●		
Finishing																													
USF	CCGT060202L-USF	0.2	0.05-2.00	0.05-0.18																○									
	CCGT060204L-USF	0.4	0.05-2.00	0.05-0.35																○									
	CCGT09T301L-USF	0.1	0.2-2.0	0.01-0.08																		●							
Finishing	CCGT09T302L-USF	0.2	0.2-2.0	0.05-0.18																	●								
	CCGT09T304L-USF	0.4	0.2-2.0	0.05-0.20																	○								
USF	CCGT09T304R-USF	0.4	0.2-2.0	0.05-0.20																○									
Finishing																													

● Ex stock   ○ On demand

HC<sup>1</sup> Coated carbide  
 HT Uncoated cermet  
 HC<sup>2</sup> Coated cermet  
 HW Uncoated carbide

**B**

Milling

**C**

Drilling

**D**

Technical Information

**E**

Index

Tool holder						
SCACR/L	SCLCR/L	SCACR/L-SC	SCLCR/L-SC	S***-SCLCR/L	S***-SCFCR/L	S***-SCLCR
Kr: 90°	Kr: 95°	Kr: 90°	Kr: 95°	Kr: 95°	Kr: 90°	Kr: 95°
A269	A270	A306	A307	A334	A352	A353
<b>E***-SCLCR/L</b>						
Kr: 95°						
A355						



CCMT	L	I.C	S	d
06 02	6.4	6.35	2.38	2.8
09 T3	9.7	9.525	3.97	4.4
12 04	12.9	12.7	4.76	5.56

- Ideal machining conditions
- ⊗ Normal machining conditions
- ⊗ Unfavourable machining conditions

**Turning inserts**

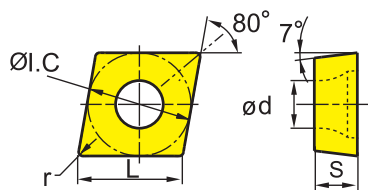

CC** positive insert				HC <sup>1</sup> (CVD)								HC <sup>1</sup> (PVD)			HT	HC <sup>2</sup>	HW																
				P	M	K	N	S	H																								
ISO				r	a <sub>p</sub>	f	YBC103	YB6315	YBC152	YBC203	YBC252	YBC352	YBM153	YBM253	YBD102	YB7315	YBD152	YBD152C	YBG101	YBG102	YBG105	YBG205	YB9320	YPD201	YBS103	YNG151	YNT251	YNG151C	YD101	YD201			
<b>AHF</b>  Finishing	<b>CCMT060204-AHF</b>	0.4	0.2-2.5	0.05-0.20	●																												
	<b>CCMT060208-AHF</b>	0.8	0.3-2.5	0.05-0.30	○																												
	<b>CCMT09T302-AHF</b>	0.2	0.08-2.00	0.04-0.15																													
	<b>CCMT09T304-AHF</b>	0.4	0.2-3.0	0.05-0.30	●																		○	●	○								
	<b>CCMT09T308-AHF</b>	0.8	0.3-3.0	0.05-0.40	●																		○	●									
	<b>CCMT120404-AHF</b>	0.4	0.5-4.0	0.05-0.30	○																		○	●									
	<b>CCMT120408-AHF</b>	0.8	0.8-4.0	0.08-0.40	●																			●									
<b>HF</b>  Finishing	<b>CCMT060202-HF</b>	0.2	0.06-1.70	0.03-0.11	●	●																											
	<b>CCMT060204-HF</b>	0.4	0.1-1.7	0.05-0.17	●	●																											
	<b>CCMT060208-HF</b>	0.8	0.1-1.7	0.05-0.30	○	●																											
	<b>CCMT09T302-HF</b>	0.2	0.08-2.00	0.04-0.15	●	●																											
	<b>CCMT09T304-HF</b>	0.4	0.11-2.00	0.06-0.23	●	●										○	●																
	<b>CCMT09T308-HF</b>	0.8	0.15-2.00	0.08-0.30	●	●										○	●																
	<b>CCMT120404-HF</b>	0.4	0.14-2.40	0.07-0.27	●	●																											
<b>CCMT120408-HF</b>	0.8	0.2-3.0	0.08-0.30	●	○																												

● Ex stock ○ On demand  
 YBC152F, YBC252F, YBM153F, YBM253F available

HC<sup>1</sup> Coated carbide  
 HT Uncoated cermet  
 HC<sup>2</sup> Coated cermet  
 HW Uncoated carbide

Tool holder						
SCACR/L	SCLCR/L	SCACR/L-SC	SCLCR/L-SC	A***-SCLCR/L	S***-SCFCR/L	S***-SCLCR
Kr: 90°	Kr: 95°	Kr: 90°	Kr: 95°	Kr: 95°	Kr: 90°	Kr: 95°
A269	A270	A306	A307	A334	A352	A353
E***-SCLCR/L						
Kr: 95°						
A355						

System code > A48

Grade selection > A42

Technical info > A501

Cutting data > A366



**A** Turning  
**B** Milling  
**C** Drilling  
**D** Technical Information  
**E** Index

**A**

Turning

**B**

Milling

**C**

Drilling

**D**

Technical Information

**E**

Index

CCMT	L	I.C	S	d
06 02	6.4	6.35	2.38	2.8
09 T3	9.7	9.525	3.97	4.4
12 04	12.9	12.7	4.76	5.56

- Ideal machining conditions
- ⊗ Normal machining conditions
- ⊗ Unfavourable machining conditions

## Turning inserts

CC** positive insert				HC <sup>1</sup> (CVD)								HC <sup>1</sup> (PVD)				HT	HC <sup>2</sup>	HW														
	P	M	K	N	S	H	YBC103	YB6315	YBC152	YBC203	YBC252	YBC352	YBM153	YBM253	YBD102	YB7315	YBD152	YBD152C	YBG101	YBG102	YBG105	YBG205	YB9320	YPD201	YBS103	YNG151	YNT251	YNG151C	YD101	YD201		
	ISO	r	a <sub>p</sub>	f																												
	 Finishing	CCMT060202-EF	0.2	0.06-1.70	0.03-0.11									●									●									
		CCMT060204-EF	0.4	0.1-1.7	0.05-0.17									●									●									
		CCMT09T302-EF	0.2	0.08-2.00	0.04-0.15									○										●								
		CCMT09T304-EF	0.4	0.11-2.00	0.06-0.23									●										○	●							
CCMT09T308-EF		0.8	0.15-2.00	0.08-0.30									●										○	●								
CCMT120404-EF		0.4	0.14-2.40	0.07-0.27									●											●								
CCMT120408-EF		0.8	0.2-3.0	0.1-0.3									●											●								
 Finishing	CCMT060202-XF	0.2	0.5-1.5	0.08-0.15									●																			
	CCMT060208-XF	0.8	0.5-1.5	0.08-0.20	●																											
	CCMT09T302-XF	0.2	0.5-2.0	0.08-0.15	●								●																			
	CCMT09T308-XF	0.8	0.5-2.0	0.08-0.25	●								○																			

● Ex stock   ○ On demand  
 YBC152F, YBC252F, YBM153F, YBM253F available

HC<sup>1</sup> Coated carbide  
 HT Uncoated cermet  
 HC<sup>2</sup> Coated cermet  
 HW Uncoated carbide

### Tool holder

SCACR/L Kr: 90°	SCLCR/L Kr: 95°	SCACR/L-SC Kr: 90°	SCLCR/L-SC Kr: 95°	A***-SCLCR/L Kr: 95°	S***-SCFCR/L Kr: 90°	S***-SCLCR Kr: 95°
A269	A270	A306	A307	A334	A352	A353

E\*\*\*-SCLCR/L  
Kr: 95°



A355

System code > A48

Grade selection > A42

Technical info > A501

Cutting data > A366

CCMT	L	I.C	S	d
06 02	6.4	6.35	2.38	2.8
09 T3	9.7	9.525	3.97	4.4
12 04	12.9	12.7	4.76	5.56

- Ideal machining conditions
- Normal machining conditions
- Unfavourable machining conditions

**Turning inserts**

CC** positive insert				HC <sup>1</sup> (CVD)								HC <sup>1</sup> (PVD)		HT	HC <sup>2</sup>	HW	
ISO	r	a <sub>p</sub>	f	P	M	K	N	S	H								
				EM	0.4	0.2-2.4	0.06-0.17	●	●	●	●	●	●	●	●	●	●
EM	0.8	0.4-2.4	0.08-0.23		●	●	●	●	●	●	●	●	●	●	●	●	
EM	0.4	0.25-3.00	0.08-0.23														
EM	0.8	0.5-3.0	0.1-0.3														
EM	0.4	0.3-3.6	0.09-0.27														
EM	0.8	0.6-3.6	0.12-0.36														
EM	1.2	0.72-3.60	0.14-0.43														
EM	0.4	1-2.5	0.15-0.3	●	○												
EM	0.8	1-2.5	0.15-0.35	●	●												
EM	1.2	1-2.5	0.15-0.4	●	●												
EM	0.4	1-3.0	0.15-0.3	○	○												
EM	0.8	1-3.0	0.15-0.35	○	○												
EM	1.2	1-3.0	0.15-0.4	○	○												

● Ex stock ○ On demand  
 YBC152F, YBC252F, YBM153F, YBM253F available

HC<sup>1</sup> Coated carbide  
 HT Uncoated cermet  
 HC<sup>2</sup> Coated cermet  
 HW Uncoated carbide

Tool holder						
SCACR/L	SCLCR/L	SCACR/L-SC	SCLCR/L-SC	A***-SCLCR/L	S***-SCFCR/L	S***-SCLCR
Kr: 90°	Kr: 95°	Kr: 90°	Kr: 95°	Kr: 95°	Kr: 90°	Kr: 95°
A269	A270	A306	A307	A334	A352	A353

E***-SCLCR/L
Kr: 95°
A355



**A** Turning  
**B** Milling  
**C** Drilling  
**D** Technical Information  
**E** Index



**A**

Turning

**B**

Milling

**C**

Drilling

**D**

Technical Information

**E**

Index

- Ideal machining conditions
- ⊗ Normal machining conditions
- ⊗ Unfavourable machining conditions

CCMT	L	I.C	S	d
<b>06 02</b>	6.4	6.35	2.38	2.8
<b>09 T3</b>	9.7	9.525	3.97	4.4
<b>12 04</b>	12.9	12.7	4.76	5.56

## Turning inserts

CC** positive insert				HC <sup>1</sup> (CVD)								HC <sup>1</sup> (PVD)			HT	HC <sup>2</sup>	HW														
	P	M	K	N	S	H	YBC103	YB6315	YBC152	YBC203	YBC252	YBC352	YBM153	YBM253	YBD102	YB7315	YBD152	YBD152C	YBG101	YBG102	YBG105	YBG205	YB9320	YPD201	YBS103	YNG151	YNT251	YNG151C	YD101	YD201	
	ISO	r	a <sub>p</sub>	f																											
	HM	<b>CCMT060204-HM</b>	0.4	0.2-2.4	0.06-0.17	●	●																								
		<b>CCMT060208-HM</b>	0.8	0.2-3.0	0.08-0.20	●	●																								
	Medium Cut	<b>CCMT09T304-HM</b>	0.4	0.25-3.00	0.08-0.23	●	●																								
		<b>CCMT09T308-HM</b>	0.8	0.5-3.0	0.1-0.3	●	●																								
	<b>CCMT120404-HM</b>	0.4	0.3-3.6	0.09-0.27	●	●									○																
	<b>CCMT120408-HM</b>	0.8	0.6-3.6	0.12-0.36	●	●									●																
	<b>CCMT120412-HM</b>	1.2	0.72-3.60	0.14-0.43	●	○									○																

● Ex stock   ○ On demand  
 YBC152F, YBC252F, YBM153F, YBM253F available

HC<sup>1</sup> Coated carbide  
 HT Uncoated cermet  
 HC<sup>2</sup> Coated cermet  
 HW Uncoated carbide

Tool holder						
SCACR/L	SCLCR/L	SCACR/L-SC	SCLCR/L-SC	A***-SCLCR/L	S***-SCFCR/L	S***-SCLCR
Kr: 90°	Kr: 95°	Kr: 90°	Kr: 95°	Kr: 95°	Kr: 90°	Kr: 95°
A269	A270	A306	A307	A334	A352	A353

E***-SCLCR/L
Kr: 95°
A355



CC**	L	I.C	S	d
06 02	6.4	6.35	2.38	2.8
09 T3	9.7	9.525	3.97	4.4
12 04	12.9	12.7	4.76	5.56

- Ideal machining conditions
- Normal machining conditions
- Unfavourable machining conditions

**Turning inserts**

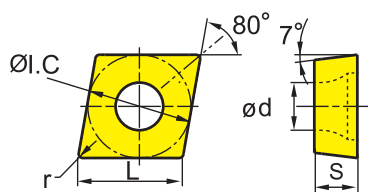

CC** positive insert				HC <sup>1</sup> (CVD)								HC <sup>1</sup> (PVD)			HT	HC <sup>2</sup>	HW															
				P	M	K	N	S	H																							
ISO				r	a <sub>p</sub>	f	YBC103	YB6315	YBC152	YBC203	YBC252	YBC352	YBM153	YBM253	YBD102	YB7315	YBD152	YBD152C	YBG101	YBG102	YBG105	YBG205	YB9320	YPD201	YBS103	YNG151	YNT251	YNG151C	YD101	YD201		
Basic 	CCMW09T304	0.4	0.1-5.0	0.05-0.50																												
	CCMW120404	0.4	0.2-5.0	0.05-0.50																												
	CCMW120408	0.8	0.5-5.0	0.08-0.50																												
Medium Cut																																
TC 	CCMT060204-TC	0.4	0.5-3.0	0.1-0.3																												
	CCMT09T304-TC	0.4	0.5-3.0	0.1-0.3																												
	CCMT09T308-TC	0.8	0.5-3.0	0.1-0.4																												
	CCMT120404-TC	0.4	1-4	0.1-0.3																												
Medium Cut																																
HR 	CCMT060204-HR	0.4	0.5-3.0	0.05-0.24																												
	CCMT060208-HR	0.8	0.8-3.2	0.09-0.26																												
	CCMT09T304-HR	0.4	0.2-4.0	0.05-0.30																												
	CCMT09T308-HR	0.8	1-4	0.12-0.35																												
	CCMT120408-HR	0.8	1.2-4.8	0.14-0.42																												
Rowing																																
	CCMT120412-HR	1.2	1.44-4.80	0.17-0.50																												

● Ex stock ○ On demand  
YBC152F, YBC252F, YBM153F, YBM253F available

HC<sup>1</sup> Coated carbide  
HT Uncoated cermet  
HC<sup>2</sup> Coated cermet  
HW Uncoated carbide

Tool holder						
SCACR/L	SCLCR/L	SCACR/L-SC	SCLCR/L-SC	A***-SCLCR/L	S***-SCFCR/L	S***-SCLCR
Kr: 90°	Kr: 95°	Kr: 90°	Kr: 95°	Kr: 95°	Kr: 90°	Kr: 95°
A269	A270	A306	A307	A334	A352	A353

E***-SCLCR/L
Kr: 95°
A355

**A**

Turning

**B**

Milling

**C**

Drilling

**D**

Technical Information

**E**

Index

- Ideal machining conditions
- ● Normal machining conditions
- ● ● Unfavourable machining conditions

CCGX	L	I.C	S	d
<b>06 02</b>	6.4	6.35	2.38	2.8
<b>09 T3</b>	9.7	9.525	3.97	4.4
<b>12 04</b>	12.9	12.7	4.76	5.56

## Turning inserts

CC** positive insert				HC <sup>1</sup> (CVD)										HC <sup>1</sup> (PVD)			HT	HC <sup>2</sup>	HW																				
ISO	r	a <sub>p</sub>	f	P	M	K	N	S	H	YBC103	YB6315	YBC152	YBC203	YBC252	YBC352	YBM153	YBM253	YBD102	YB7315	YBD152	YBD152C	YBG101	YBG102	YBG105	YBG205	YB9320	YPD201	YBS103	YNG151	YNT251	YNG151C	YD101	YD201						
				LC	0.2	0.3-3.0	0.05-0.15	●	●	●	●	●	●													●	●	●	●	●	●	●	●	●	●	●	●	●	
Alum Machining	0.4	0.5-3.0	0.1-0.3																			●	●	●	●	●	●	●	●	●	●	●	●	●	●				
	0.2	0.5-4.0	0.1-0.2																			●	●	●	●	●	●	●	●	●	●	●	●	●	●				
	0.4	0.5-5.0	0.1-0.3																			●	●	●	●	●	●	●	●	●	●	●	●	●	●	●			
	0.8	0.5-5.0	0.15-0.60																			●	●	●	●	●	●	●	●	●	●	●	●	●	●	●			
	0.4	0.5-7.0	0.1-0.3																			●	●	●	●	●	●	●	●	●	●	●	●	●	●	●			
	0.8	0.5-7.0	0.15-0.60																			●	●	●	●	●	●	●	●	●	●	●	●	●	●	●	●		
LH	0.2	0.3-3.0	0.05-0.15																			●	●	●	●	●	●	●	●	●	●	●	●	●	●	●			
Alum Machining	0.4	0.5-3.0	0.1-0.3																			○	○	○	○	○	○	○	○	○	○	○	○	○	○	○			
	0.8	0.6-3.0	0.15-0.40																			○	○	○	○	○	○	○	○	○	○	○	○	○	○	○	○		
	0.2	0.4-5.0	0.05-0.15																			○	○	○	○	○	○	○	○	○	○	○	○	○	○	○	○		
	0.4	0.5-5.0	0.1-0.3																			○	○	○	○	○	○	○	○	○	○	○	○	○	○	○	○	○	
	0.8	0.5-5.0	0.15-0.60																			○	○	○	○	○	○	○	○	○	○	○	○	○	○	○	○	○	
	0.2	0.4-7.0	0.05-0.15																			○	○	○	○	○	○	○	○	○	○	○	○	○	○	○	○	○	
	0.4	0.5-7.0	0.1-0.3																			○	○	○	○	○	○	○	○	○	○	○	○	○	○	○	○	○	○
	0.8	0.5-7.0	0.15-0.60																			○	○	○	○	○	○	○	○	○	○	○	○	○	○	○	○	○	○
	1.2	0.5-7.0	0.15-0.80																			○	○	○	○	○	○	○	○	○	○	○	○	○	○	○	○	○	○

● Ex stock   ○ On demand

HC<sup>1</sup> Coated carbide  
 HT Uncoated cermet  
 HC<sup>2</sup> Coated cermet  
 HW Uncoated carbide



System code > A48

Grade selection > A42

Technical info > A501

Cutting data > A366

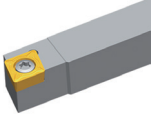
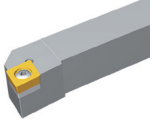
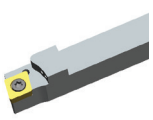
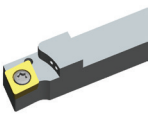
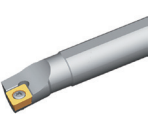
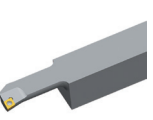

Tool holder						
SCACR/L	SCLCR/L	SCACR/L-SC	SCLCR/L-SC	A***-SCLCR/L	S***-SCFCR/L	S***-SCLCR
Kr: 90°	Kr: 95°	Kr: 90°	Kr: 95°	Kr: 95°	Kr: 90°	Kr: 95°
						
A269	A270	A306	A307	A334	A352	A353

E***-SCLCR/L
Kr: 95°

A355

<b>A</b>	Turning
<b>B</b>	Milling
<b>C</b>	Drilling
<b>D</b>	Technical Information
<b>E</b>	Index

System code > A48

Grade selection > A42

Technical info > A501

Cutting data > A366

# General turning Positive inserts

**A**

Turning

- Ideal machining conditions
- ⊗ Normal machining conditions
- ⊗ Unfavourable machining conditions

CP**	L	I.C	S	d
06 02	6.4	6.35	2.38	2.8
09 T3	9.7	9.525	3.97	4.4

## Turning inserts

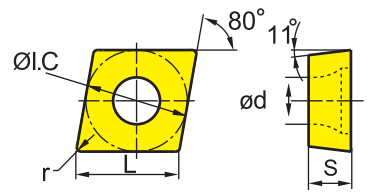

CP** positive insert					HC <sup>1</sup> (CVD)								HC <sup>1</sup> (PVD)		HT	HC <sup>2</sup>	HW											
					P	M	K	N	S	H																		
					YBC103	YB6315	YBC152	YBC203	YBC252	YBC352	YBM153	YBM253	YBD102	YB7315	YBD152	YBD152C	YBG101	YBG102	YBG105	YBG205	YB9320	YPD201	YBS103	YNG151	YNT251	YNG151C	YD101	YD201
ISO	r	a <sub>p</sub>	f																									
HF 	CPMT060204-HF	0.4	0.1-1.5	0.04-0.18																								
	CPMT060208-HF	0.8	0.1-1.5	0.05-0.25																								
SF 	CPGT060202-SF	0.2	0.05-2.00	0.05-0.25																								
	CPGT060204-SF	0.4	0.05-2.00	0.05-0.35																								
	CPGT09T304-SF	0.4	0.05-2.00	0.05-0.35																								
Flat 	CPGW060204	0.4	0.5-1.5	0.05-0.40																								
HM 	CPMT09T304-HM	0.4	0.2-3.5	0.05-0.35																								
	CPMT09T308-HM	0.8	0.2-3.5	0.10-0.55																								

● Ex stock    ○ On demand  
 YBC152F, YBC252F, YBM153F, YBM253F available

HC<sup>1</sup> Coated carbide  
 HT Uncoated cermet  
 HC<sup>2</sup> Coated cermet  
 HW Uncoated carbide

**B**

Milling

**C**

Drilling

**D**

Technical Information

**E**

Index

Tool holder	
S***-SCLPR/L	C***-SCLPR/L
Kr: 95°	Kr: 95°
A348	A354



- Ideal machining conditions
- Normal machining conditions
- Unfavourable machining conditions

DC**	L	I.C	S	d
07 02	7.8	6.35	2.38	2.8
11 T3	11.6	9.525	3.97	4.4

**Turning inserts**

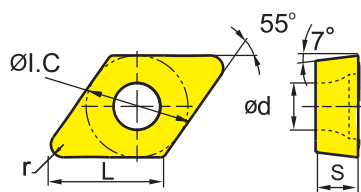

DC** positive insert				HC <sup>1</sup> (CVD)								HC <sup>1</sup> (PVD)				HT	HC <sup>2</sup>	HW																
				P	M	K	N	S	H																									
ISO				r	a <sub>p</sub>	f	YBC103	YB6315	YBC152	YBC203	YBC252	YBC352	YBM153	YBM253	YBD102	YBD7315	YBD152	YBD152C	YBG101	YBG102	YBG105	YBG205	YB9320	YPD201	YBS103	YNG151	YNT251	YNG151C	YD101	YD201				
AHF	<b>DCMT070204-AHF</b>			0.4	0.2-2.5	0.05-0.20	○															○	●			●								
	<b>DCMT11T302-AHF</b>			0.2	0.5-3.0	0.05-0.15	○																●	●			●	●						
	<b>DCMT11T304-AHF</b>			0.4	0.5-3.0	0.05-0.30	●																●	●			●							
	<b>DCMT11T308-AHF</b>			0.8	0.5-3.0	0.05-0.40	●																	●			●							
SF	<b>DCGT070202-SF</b>			0.2	0.05-1.50	0.05-0.15																				●	●	○						
	<b>DCGT070204-SF</b>			0.4	0.05-1.50	0.05-0.20																				○		●						
	<b>DCGT070208-SF</b>			0.8	0.05-1.50	0.05-0.30																						●						
	<b>DCGT11T302-SF</b>			0.2	0.05-2.00	0.05-0.15														○							○	●	●					
	<b>DCGT11T304-SF</b>			0.4	0.05-2.00	0.05-0.20																					●	●	●					
	<b>DCGT11T308-SF</b>			0.8	0.05-2.00	0.05-0.30																					●	●						

● Ex stock ○ On demand

YBC152F, YBC252F, YBM153F, YBM253F available

HC<sup>1</sup> Coated carbide  
 HT Uncoated cermet  
 HC<sup>2</sup> Coated cermet  
 HW Uncoated carbide

**Tool holder**

SDACR/L	SDJCR/L	SDNCN	SDACR/L-SC	SDHCR/L-SC	SDJCR/L-SC	SDNCN-SC
Kr: 90°	Kr: 93°	Kr: 62°30'	Kr: 90°	Kr: 107°30'	Kr: 93°	Kr: 62°30'
A271	A272	A273	A308	A309	A310	A311
S***-SDQCR/L	A***-SDUCR/L	S***-SDZCR/L	E***-SDQCR/L			
Kr: 107°30'	Kr: 93°	Kr: 85°	Kr: 107°30'			
A336	A337	A338	A357			

System code > A48

Grade selection > A42

Technical info > A501

Cutting data > A366



# General turning Positive inserts

**A**

Turning

- Ideal machining conditions
- ⊗ Normal machining conditions
- ⊗ Unfavourable machining conditions

DCMT	L	I.C	S	d
<b>07 02</b>	7.8	6.35	2.38	2.8
<b>11 T3</b>	11.6	9.525	3.97	4.4

## Turning inserts

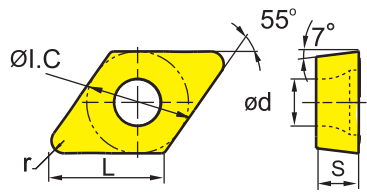

DC** positive insert					HC <sup>1</sup> (CVD)								HC <sup>1</sup> (PVD)		HT	HC <sup>2</sup>	HW											
					P	M	K	N	S	H																		
	ISO	r	a <sub>p</sub>	f	YBC103	YB6315	YBC152	YBC203	YBC252	YBC352	YBM153	YBM253	YBD102	YB7315	YBD152	YBD152C	YBG101	YBG102	YBG105	YBG205	YB9320	YPD201	YBS103	YNG151	YNT251	YNG151C	YD101	YD201
EF 	<b>DCMT070202-EF</b>	0.2	0.06-1.50	0.03-0.11							○									○								
	<b>DCMT070204-EF</b>	0.4	0.08-1.50	0.05-0.17							●									●								
	<b>DCMT11T302-EF</b>	0.2	0.08-2.00	0.04-0.15								○								●								
	<b>DCMT11T304-EF</b>	0.4	0.11-2.00	0.06-0.23								●								●								
Finishing	<b>DCMT11T308-EF</b>	0.8	0.15-2.00	0.08-0.30							●								●	●								
	<b>DCMT070202-HF</b>	0.2	0.06-1.50	0.03-0.11			○	●																				
	<b>DCMT070204-HF</b>	0.4	0.08-1.50	0.05-0.17			●	●																				
	<b>DCMT070208-HF</b>	0.8	0.08-1.50	0.05-0.30			●	○																				
Finishing	<b>DCMT11T302-HF</b>	0.2	0.08-2.00	0.04-0.15			○	●												○								
	<b>DCMT11T304-HF</b>	0.4	0.11-2.00	0.06-0.23			●	●					○	●														
	<b>DCMT11T308-HF</b>	0.8	0.15-2.00	0.08-0.30			●	●					●															
	<b>DCMT070202-XF</b>	0.2	0.5-1.5	0.08-0.15				○																				
Finishing	<b>DCMT070204-XF</b>	0.4	0.5-1.5	0.08-0.15	○																							
	<b>DCMT070208-XF</b>	0.8	0.5-1.5	0.08-0.25	○																							
	<b>DCMT11T304-XF</b>	0.4	0.5-2.0	0.08-0.15	○																							
	<b>DCMT11T308-XF</b>	0.8	0.5-2.0	0.08-0.25	○																							

● Ex stock ○ On demand  
 YBC152F, YBC252F, YBM153F, YBM253F available

HC<sup>1</sup> Coated carbide  
 HT Uncoated cermet  
 HC<sup>2</sup> Coated cermet  
 HW Uncoated carbide

**B**

Milling

**C**

Drilling

**D**

Technical Information

**E**

Index

Tool holder						
SDACR/L	SDJCR/L	SDNCN	SDACR/L-SC	SDHCR/L-SC	SDJCR/L-SC	SDNCN-SC
Kr: 90°	Kr: 93°	Kr: 62°30'	Kr: 90°	Kr: 107°30'	Kr: 93°	Kr: 62°30'
A271	A272	A273	A308	A309	A310	A311
S***-SDQCR/L	A***-SDUCR/L	S***-SDZCR/L	E***-SDQCR/L			
Kr: 107°30'	Kr: 93°	Kr: 85°	Kr: 107°30'			
A336	A337	A338	A357			



- Ideal machining conditions
- Normal machining conditions
- Unfavourable machining conditions

DCMT	L	I.C	S	d
07 02	7.8	6.35	2.38	2.8
11 T3	11.6	9.525	3.97	4.4

**Turning inserts**

DC** positive insert				HC <sup>1</sup> (CVD)							HC <sup>1</sup> (PVD)			HT	HC <sup>2</sup>	HW											
				P	M	K	N	S	H																		
ISO	r	a <sub>p</sub>	f	YBC103	YB6315	YBC152	YBC203	YBC252	YBC352	YBM153	YBM253	YBD102	YB7315	YBD152	YBD152C	YBG101	YBG102	YBG105	YBG205	YB9320	YPD201	YBS103	YNG151	YNT251	YNG151C	YD101	YD201
EM	<b>DCMT070204-EM</b>	0.4	0.19-2.25	0.06-0.17						●	●								●								
	<b>DCMT070208-EM</b>	0.8	0.38-2.25	0.08-0.23						●	○								●								
	<b>DCMT11T304-EM</b>	0.4	0.25-3.00	0.08-0.23						●	●								●								
Medium Cut	<b>DCMT11T308-EM</b>	0.8	0.5-3.0	0.1-0.3						●	●								●								
XM	<b>DCMT11T304-XM</b>	0.4	1-2.5	0.15-0.3	●	○																					
	<b>DCMT11T308-XM</b>	0.8	1-2.5	0.15-0.35	●		●																				
Medium Cut	<b>DCMT11T312-XM</b>	1.2	1-2.5	0.15-0.4	●		●																				

● Ex stock ○ On demand  
 YBC152F, YBC252F, YBM153F, YBM253F available

HC<sup>1</sup> Coated carbide  
 HT Uncoated cermet  
 HC<sup>2</sup> Coated cermet  
 HW Uncoated carbide

Tool holder						
SDACR/L	SDJCR/L	SDNCN	SDACR/L-SC	SDHCR/L-SC	SDJCR/L-SC	SDNCN-SC
Kr: 90°	Kr: 93°	Kr: 62°30'	Kr: 90°	Kr: 107°30'	Kr: 93°	Kr: 62°30'
A271	A272	A273	A308	A309	A310	A311
S***-SDQCR/L	A***-SDUCR/L	S***-SDZCR/L	E***-SDQCR/L			
Kr: 107°30'	Kr: 93°	Kr: 85°	Kr: 107°30'			
A336	A337	A338	A357			



# General turning Positive inserts

**A**

Turning

- Ideal machining conditions
- ⊗ Normal machining conditions
- ⊗ Unfavourable machining conditions

DCMT	L	I.C	S	d
07 02	7.8	6.35	2.38	2.8
11 T3	11.6	9.525	3.97	4.4

## Turning inserts

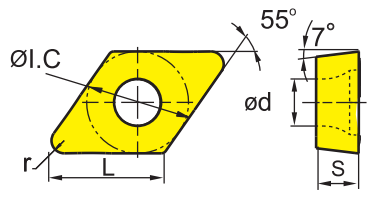

DC** positive insert				HC <sup>1</sup> (CVD)								HC <sup>1</sup> (PVD)		HT	HC <sup>2</sup>	HW												
ISO	r	a <sub>p</sub>	f	YBC103	YB6315	YBC152	YBC203	YBC252	YBC352	YBM153	YBM253	YBD102	YB7315	YBD152	YBD152C	YBG101	YBG102	YBG105	YBG205	YB9320	YPD201	YBS103	YNG151	YNT251	YNG151C	YD101	YD201	
HM	<b>DCMT070204-HM</b>	0.4	0.19-2.25	0.06-0.17	○	●	●					●	●						●									
	<b>DCMT070208-HM</b>	0.8	0.38-2.25	0.08-0.23		●	●					●	●															
	<b>DCMT11T304-HM</b>	0.4	0.25-3.00	0.08-0.23	○	●	●					●	●							●								
	<b>DCMT11T308-HM</b>	0.8	0.5-3.0	0.1-0.3		●	●					●	●							●								
Medium Cut	<b>DCMT11T312-HM</b>	1.2	0.6-3.0	0.12-0.36								○	○	○														

● Ex stock    ○ On demand  
 YBC152F, YBC252F, YBM153F, YBM253F available

- HC<sup>1</sup> Coated carbide
- HT Uncoated cermet
- HC<sup>2</sup> Coated cermet
- HW Uncoated carbide

**B**

Milling

Tool holder						
SDACR/L	SDJCR/L	SDNCN	SDACR/L-SC	SDHCR/L-SC	SDJCR/L-SC	SDNCN-SC
Kr: 90°	Kr: 93°	Kr: 62°30'	Kr: 90°	Kr: 107°30'	Kr: 93°	Kr: 62°30'
A271	A272	A273	A308	A309	A310	A311

**C**

Drilling

S***-SDQCR/L	A***-SDUCR/L	S***-SDZCR/L	E***-SDQCR/L
Kr: 107°30'	Kr: 93°	Kr: 85°	Kr: 107°30'
A336	A337	A338	A357

**D**

Technical Information

**E**

Index



**Turning inserts**

- Ideal machining conditions
- Normal machining conditions
- Unfavourable machining conditions

DC**	L	I.C	S	d
07 02	7.8	6.35	2.38	2.8
11 T3	11.6	9.525	3.97	4.4

DC** positive insert				HC <sup>1</sup> (CVD)								HC <sup>1</sup> (PVD)			HT	HC <sup>2</sup>	HW																														
				P	M	K	N	S	H																																						
				<table border="1"> <thead> <tr> <th>ISO</th> <th>r</th> <th>a<sub>p</sub></th> <th>f</th> <th>YBC103</th> <th>YB6315</th> <th>YBC152</th> <th>YBC203</th> <th>YBC252</th> <th>YBC352</th> <th>YBM153</th> <th>YBM253</th> <th>YBD102</th> <th>YB7315</th> <th>YBD152</th> <th>YBD152C</th> <th>YBG101</th> <th>YBG102</th> <th>YBG105</th> <th>YBG205</th> <th>YB9320</th> <th>YPD201</th> <th>YBS103</th> <th>YNG151</th> <th>YNT251</th> <th>YNG151C</th> <th>YD101</th> <th>YD201</th> </tr> </thead> </table>																ISO	r	a <sub>p</sub>	f	YBC103	YB6315	YBC152	YBC203	YBC252	YBC352	YBM153	YBM253	YBD102	YB7315	YBD152	YBD152C	YBG101	YBG102	YBG105	YBG205	YB9320	YPD201	YBS103	YNG151	YNT251	YNG151C	YD101	YD201
ISO	r	a <sub>p</sub>	f	YBC103	YB6315	YBC152	YBC203	YBC252	YBC352	YBM153	YBM253	YBD102	YB7315	YBD152	YBD152C	YBG101	YBG102	YBG105	YBG205	YB9320	YPD201	YBS103	YNG151	YNT251	YNG151C	YD101	YD201																				
Flat 	<b>DCMW11T304</b>			0.4	0.5-5.0	0.05-0.20																																									
	<b>DCMW11T308</b>			0.8	0.4-5.0	0.1-0.4																																									
Medium Cut																																															
HR 	<b>DCMT11T304-HR</b>			0.4	1-4	0.1-0.3																																									
	<b>DCMT11T308-HR</b>			0.8	1-4	0.12-0.35																																									
	<b>DCMT11T312-HR</b>			1.2	1.2-4.0	0.14-0.42																																									
Roughing																																															
LC 	<b>DCGX070201-LC</b>			0.1	0.3-4.0	0.05-0.10																																									
	<b>DCGX070202-LC</b>			0.2	0.3-4.0	0.05-0.15																																									
	<b>DCGX070204-LC</b>			0.4	0.5-4.0	0.1-0.3																																									
	<b>DCGX11T302-LC</b>			0.2	0.3-5.5	0.05-0.15																																									
	<b>DCGX11T304-LC</b>			0.4	0.5-5.5	0.1-0.3																																									
	<b>DCGX11T308-LC</b>			0.8	0.5-5.5	0.15-0.60																																									

● Ex stock ○ On demand  
YBC152F, YBC252F, YBM153F, YBM253F available

HC<sup>1</sup> Coated carbide  
HT Uncoated cermet  
HC<sup>2</sup> Coated cermet  
HW Uncoated carbide

Tool holder						
<b>SDACR/L</b> Kr: 90°	<b>SDJCR/L</b> Kr: 93°	<b>SDNCN</b> Kr: 62°30'	<b>SDACR/L-SC</b> Kr: 90°	<b>SDHCR/L-SC</b> Kr: 107°30'	<b>SDJCR/L-SC</b> Kr: 93°	<b>SDNCN-SC</b> Kr: 62°30'
A271	A272	A273	A308	A309	A310	A311
<b>S***-SDQCR/L</b> Kr: 107°30'	<b>A***-SDUCR/L</b> Kr: 93°	<b>S***-SDZCR/L</b> Kr: 85°	<b>E***-SDQCR/L</b> Kr: 107°30'			
A336	A337	A338	A357			

System code > A48

Grade selection > A42

Technical info > A501

Cutting data > A366



A

Turning

B

Milling

C

Drilling

D

Technical Information

E

Index

A

Turning

- Ideal machining conditions
- Normal machining conditions
- Unfavourable machining conditions

DCGX	L	I.C	S	d
07 02	7.8	6.35	2.38	2.8
11 T3	11.6	9.525	3.97	4.4

## Turning inserts

DC** positive insert			HC <sup>1</sup> (CVD)								HC <sup>1</sup> (PVD)		HT	HC <sup>2</sup>	HW	
	<b>P</b>	●●●●●●●●									●●	●●				
	<b>M</b>		●●●●									●●●●●●●●	●●●●			
	<b>K</b>															
	<b>N</b>											●●			●●●●	
	<b>S</b>											●●●●●●●●			●●●●	
	<b>H</b>															

B

Milling

ISO		r	a <sub>p</sub>	f	YBC103	YB6315	YBC152	YBC203	YBC252	YBC352	YBM153	YBM253	YBD102	YB7315	YBD152	YBD152C	YBG101	YBG102	YBG105	YBG205	YB9320	YPD201	YBS103	YNG151	YNT251	YNG151C	YD101	YD201		
	<b>DCGX070202-LH</b>	0.2	0.3-4.0	0.05-0.15													●										●			
	<b>DCGX070204-LH</b>	0.4	0.5-4.0	0.1-0.3														●										●		
	<b>DCGX070208-LH</b>	0.8	0.5-4.0	0.15-0.60														○											●	
	<b>DCGX11T302-LH</b>	0.2	0.3-5.5	0.05-0.15																									●	
	<b>DCGX11T304-LH</b>	0.4	0.5-5.5	0.1-0.3																									●	
	<b>DCGX11T308-LH</b>	0.8	0.5-5.5	0.15-0.60																									●	

● Ex stock ○ On demand

HC<sup>1</sup> Coated carbide  
HT Uncoated cermet  
HC<sup>2</sup> Coated cermet  
HW Uncoated carbide

C

Drilling

Tool holder						
SDACR/L	SDJCR/L	SDNCN	SDACR/L-SC	SDHCR/L-SC	SDJCR/L-SC	SDNCN-SC
Kr: 90°	Kr: 93°	Kr: 62°30'	Kr: 90°	Kr: 107°30'	Kr: 93°	Kr: 62°30'
A271	A272	A273	A308	A309	A310	A311

D

Technical Information

S***-SDQCR/L	A***-SDUCR/L	S***-SDZCR/L	E***-SDQCR/L
Kr: 107°30'	Kr: 93°	Kr: 85°	Kr: 107°30'
A336	A337	A338	A357

E

Index

**Turning inserts**

- Ideal machining conditions
- Normal machining conditions
- Unfavourable machining conditions

DPGT	L	I.C	S	d
07 02	7.8	6.35	2.38	2.8
11 T3	11.6	9.525	3.97	4.4

DP** positive insert				HC <sup>1</sup> (CVD)								HC <sup>1</sup> (PVD)			HT	HC <sup>2</sup>	HW											
				<b>P</b>	●	●	●	●	●	●	●	●	●	●	●	●												
				<b>M</b>									●	●	●	●	●	●										
				<b>K</b>																								
				<b>N</b>										●	●				●	●								
				<b>S</b>																●	●							
				<b>H</b>																								
ISO	r	a <sub>p</sub>	f	YBC103	YB6315	YBC152	YBC203	YBC252	YBC352	YBM153	YBM253	YBD102	YB7315	YBD152	YBD152C	YBG101	YBG102	YBG105	YBG205	YB9320	YPD201	YBS103	YNG151	YNT251	YNG151C	YD101	YD201	
SF  Finishing	<b>DPGT070202-SF</b>	0.2	0.05-2.00	0.05-0.15																				○	●			
	<b>DPGT070204-SF</b>	0.4	0.05-2.00	0.05-0.30																					●	●		
	<b>DPGT11T304-SF</b>	0.4	0.05-2.00	0.1-0.3																					●	●		
	<b>DPGT11T308-SF</b>	0.8	0.05-2.00	0.1-0.4																					○	○		

● Ex stock ○ On demand

HC<sup>1</sup> Coated carbide  
 HT Uncoated cermet  
 HC<sup>2</sup> Coated cermet  
 HW Uncoated carbide

Tool holder		
S***-SDQPR/L	S***-SDUPR/L	C***-SDQPR/L
Kr: 107°30'	Kr: 93°	Kr: 107°30'
A349	A350	A356

System code > A48

Grade selection > A42

Technical info > A501

Cutting data > A366



**A**  
 Turning  
**B**  
 Milling  
**C**  
 Drilling  
**D**  
 Technical Information  
**E**  
 Index

**A**

Turning

**B**

Milling

**C**

Drilling

**D**

Technical Information

**E**

Index

RC**	L	I.C	S	d
<b>08 03</b>	8	8	3.18	3.36
<b>10 T3</b>	10	10	3.97	3.6
<b>12 04</b>	12	12	4.76	44.4
<b>16 06</b>	16	16	6.35	5.5
<b>20 06</b>	20	20	6.35	6.5
<b>25 07</b>	25	25	7.94	7.7

- Ideal machining conditions
- ⊗ Normal machining conditions
- ⊗ Unfavourable machining conditions

## Turning inserts

RC** positive insert				HC <sup>1</sup> (CVD)								HC <sup>1</sup> (PVD)				HT	HC <sup>2</sup>	HW																			
ISO	a <sub>p</sub>	f	RC** positive insert	P	M	K	N	S	H	YBC103	YB6315	YBC152	YBC203	YBC252	YBC352	YBM153	YBM253	YBD102	YB7315	YBD152	YBD152C	YBG101	YBG102	YBG105	YBG205	YB9320	YPD201	YBS103	YNG151	YNT251	YNG151C	YD101	YD201				
				Basic	RCMT0803MO	0.5-3.0	0.1-0.4	●	●	●	●	●	●																								
Medium Cut	RCMT10T3MO	0.5-4.0	0.1-0.5																																		
	RCMT1204MO	0.8-5.0	0.1-0.6																																		
LH	RCMT1606MO	1-6	0.1-0.8																																		
	RCMT2006MO	1.2-8.0	0.1-1.0																																		
Alum Machining	RCMT2507MO	1.4-10.0	0.1-1.2																																		
	RCGX0803MO-LH	1-4	0.2-0.5																																		
	RCGX1204MO-LH	1.2-5.0	0.2-0.6																																		

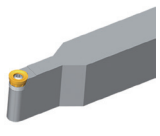
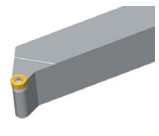

● Ex stock    ○ On demand  
 YBC152F, YBC252F, YBM153F, YBM253F available

HC<sup>1</sup> Coated carbide  
 HT Uncoated cermet  
 HC<sup>2</sup> Coated cermet  
 HW Uncoated carbide





Tool holder	
SRDCN	SRGCR/L
	
A288	A289

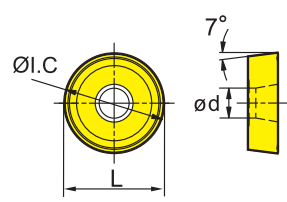

RCMX	L	I.C	S	d
<b>08 03</b>	8	8	3.18	3.36
<b>10 03</b>	10	10	3.18	4.4
<b>12 04</b>	12	12	4.76	4.4
<b>16 06</b>	16	16	6.35	5.5
<b>20 06</b>	20	20	6.35	6.5
<b>25 07</b>	25	25	7.94	7.2
<b>32 09</b>	32	32	9.52	10.2

-  Ideal machining conditions
-  Normal machining conditions
-  Unfavourable machining conditions

**Turning inserts**

RC** positive insert			HC <sup>1</sup> (CVD)										HC <sup>1</sup> (PVD)			HT	HC <sup>2</sup>	HW								
			P	M	K	N	S	H																		
ISO	a <sub>p</sub>	f	YBC103	YB6315	YBC152	YBC203	YBC252	YBC352	YBM153	YBM253	YBD102	YB7315	YBD152	YBD152C	YBG101	YBG102	YBG105	YBG205	YB9320	YPD201	YBS103	YNG151	YNT251	YNG151C	YD101	YD201
Basic  Light Roughing	<b>RCMX0803MO</b>	0.5-4.0	0.1-0.5					●																		
	<b>RCMX1003MO</b>	0.5-5.0	0.1-0.6					●																		
	<b>RCMX1204MO</b>	1-6	0.1-0.8		○			●																		
	<b>RCMX1606MO</b>	1-7	0.2-0.9		○			●		○									○							
	<b>RCMX2006MO</b>	1-9	0.2-1.0					●					●													
	<b>RCMX2507MO</b>	2-10	0.25-1.20					●																		
	<b>RCMX3209MO</b>	2-13	0.25-1.40		○			●																		
Basic  Light Roughing	<b>RCMX2507MO-1</b>	2-9	0.1-0.4		○																					
Basic  Light Roughing	<b>RCMX3209MO-PV</b>	3-12	0.1-0.4		○			●																		

● Ex stock ○ On demand  
YBC152F, YBC252F, YBM153F, YBM253F available

HC<sup>1</sup> Coated carbide  
HT Uncoated cermet  
HC<sup>2</sup> Coated cermet  
HW Uncoated carbide



**A** Turning  
  
**B** Milling  
  
**C** Drilling  
  
**D** Technical Information  
  
**E** Index





**A**

Turning

- Ideal machining conditions
- ⊗ Normal machining conditions
- ⊗ Unfavourable machining conditions

SCMT	L	I.C	S	d
09 T3	9.525	9.525	3.97	4.4
12 04	12.7	12.7	4.76	5.56

## Turning inserts

SC** positive insert					HC <sup>1</sup> (CVD)										HC <sup>1</sup> (PVD)		HT	HC <sup>2</sup>	HW											
					P	●	●	●	●	●	●	●	●	●	●	●	●	●	●	●	●									
					M																									
					K																									
					N																									
					S																									
					H																									
	ISO	r	a <sub>p</sub>	f	YBC103	YB6315	YBC152	YBC203	YBC252	YBC352	YBM153	YBM253	YBD102	YB7315	YBD152	YBD152C	YBG101	YBG102	YBG105	YBG205	YB9320	YPD201	YBS103	YNG151	YNT251	YNG151C	YD101	YD201		
AHF 	SCMT09T304-AHF	0.4	0.5-3.0	0.05-0.30	●																									
	SCMT09T308-AHF	0.8	0.5-3.0	0.05-0.40	●																				○					
Finishing																														
EF 	SCMT09T302-EF	0.2	0.07-2.00	0.05-0.15																●										
	SCMT09T304-EF	0.4	0.11-2.00	0.06-0.23																●										
	SCMT09T308-EF	0.8	0.15-2.00	0.08-0.30																●										
Finishing																														
EM 	SCMT09T304-EM	0.4	0.25-3.00	0.08-0.23																●										
	SCMT09T308-EM	0.8	0.5-3.0	0.1-0.3																●										
	SCMT120404-EM	0.4	0.3-3.6	0.09-0.27																●										
	SCMT120408-EM	0.8	0.6-3.6	0.12-0.36																●										
	SCMT120412-EM	1.2	0.72-3.60	0.14-0.43																●										
Finishing																														
XF 	SCMT09T304-XF	0.4	0.5-2.0	0.08-0.25	●																									
	SCMT09T308-XF	0.8	0.5-2.0	0.08-0.30	●																									
Finishing																														

● Ex stock   ○ On demand  
 YBC152F, YBC252F, YBM153F, YBM253F available

HC<sup>1</sup> Coated carbide  
 HT Uncoated cermet  
 HC<sup>2</sup> Coated cermet  
 HW Uncoated carbide

**B**

Milling

**C**

Drilling

**D**

Technical Information

**E**

Index

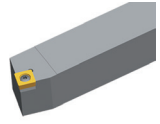
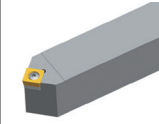
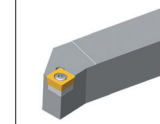
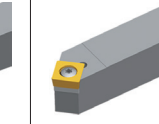
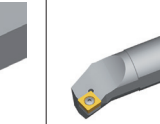
Tool holder				
SSBCR/L	SSDCN	SSKCR/L	SSSCR/L	S***-SSKCR/L
Kr: 75°	Kr: 45°	Kr: 75°	Kr: 45°	Kr: 75°
				
A279	A280	A281	A282	A339



**Turning inserts**

- Ideal machining conditions
- Normal machining conditions
- Unfavourable machining conditions

SCMT	L	I.C	S	d
09 T3	9.525	9.525	3.97	4.4
12 04	12.7	12.7	4.76	5.56

SC** positive insert				HC <sup>1</sup> (CVD)								HC <sup>1</sup> (PVD)			HT	HC <sup>2</sup>	HW															
				P	M	K	N	S	H																							
				●	●	●	●	●	●	●	●	●	●	●	●	●	●	●														
ISO				r	a <sub>p</sub>	f	YBC103	YB6315	YBC152	YBC203	YBC252	YBC352	YBM153	YBM253	YBD102	YB7315	YBD152	YBD152C	YBG101	YBG102	YBG105	YBG205	YB9320	YPD201	YBS103	YNG151	YNT251	YNG151C	YD101	YD201		
 Finishing	SCMT09T302-HF	0.2	0.15-2.00	0.05-0.15																												
	SCMT09T304-HF	0.4	0.11-2.00	0.05-0.23																												
	SCMT09T308-HF	0.8	0.15-2.00	0.05-0.30			●	●																								
 Medium Cut	SCMT09T304-HM	0.4	0.25-3.00	0.08-0.23		●	●							●	●																	
	SCMT09T308-HM	0.8	0.5-3.0	0.1-0.3		●	●							●	●																	
	SCMT120404-HM	0.4	0.3-3.6	0.09-0.27		●	●																									
	SCMT120408-HM	0.8	0.6-3.6	0.12-0.36		○	●								●	●																
 Medium Cut	SCMT09T304-XM	0.4	1-2.5	0.15-0.3	○	○																										
	SCMT09T308-XM	0.8	1-2.5	0.15-0.35	○	○																										
	SCMT09T312-XM	1.2	1-2.5	0.15-0.4	○	○																										
	SCMT120408-XM	0.8	1-3.0	0.15-0.35	○	○																										
	SCMT120412-XM	1.2	1-3.0	0.15-0.4	○	○																										

● Ex stock ○ On demand  
 YBC152F, YBC252F, YBM153F, YBM253F available

HC<sup>1</sup> Coated carbide  
 HT Uncoated cermet  
 HC<sup>2</sup> Coated cermet  
 HW Uncoated carbide

Tool holder				
SSBCR/L	SSDCN	SSKCR/L	SSSCR/L	S***-SSKCR/L
Kr: 75°	Kr: 45°	Kr: 75°	Kr: 45°	Kr: 75°
A279	A280	A281	A282	A339



A

Turning

- Ideal machining conditions
- ⊗ Normal machining conditions
- ⊗ Unfavourable machining conditions

SC**	L	I.C	S	d
09 T3	9.525	9.525	3.97	4.4
12 04	12.7	12.7	4.76	5.55.56

## Turning inserts

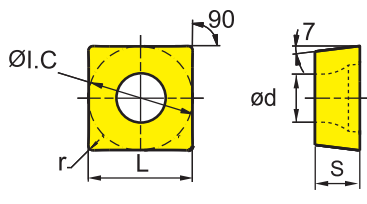

SC** positive insert					HC <sup>1</sup> (CVD)										HC <sup>1</sup> (PVD)			HT		HC <sup>2</sup>		HW							
					P										M			K		N		S		H					
 HR  Roughing	ISO	r	a <sub>p</sub>	f	YBC103	YB6315	YBC152	YBC203	YBC252	YBC352	YBM153	YBM253	YBD102	YB7315	YBD152	YBD152C	YBG101	YBG102	YBG105	YBG205	YB9320	YPD201	YBS103	YNG151	YNT251	YNG151C	YD101	YD201	
	SCMT09T304-HR	0.4	0.2-4.0	0.05-0.40			○	●																					
	SCMT09T308-HR	0.8	1-4	0.12-0.35			●	●						●	●														
	SCMT09T312-HR	1.2	1.2-4.0	0.14-0.42																									
	SCMT120404-HR	0.4	0.5-4.0	0.05-0.50			○	○																					
	SCMT120408-HR	0.8	1.2-4.8	0.14-0.42			●	●						●	●														
SCMT120412-HR	1.2	1.44-4.80	0.17-0.50			●	●						●	○															
 LC Alum Machining	SCGX09T304-LC	0.4	0.5-5.0	0.1-0.5																								●	
	SCGX09T308-LC	0.8	0.5-5.0	0.15-0.60																								●	
	SCGX120408-LC	0.8	1-7	0.15-0.60														●										●	

● Ex stock   ○ On demand  
 YBC152F, YBC252F, YBM153F, YBM253F available

HC<sup>1</sup> Coated carbide  
 HT Uncoated cermet  
 HC<sup>2</sup> Coated cermet  
 HW Uncoated carbide

B

Milling

C

Drilling

D

Technical Information

E

Index

Tool holder				
SSBCR/L	SSDCN	SSKCR/L	SSSCR/L	S***-SSKCR/L
Kr: 75°	Kr: 45°	Kr: 75°	Kr: 45°	Kr: 75°
A279	A280	A281	A282	A339



- Ideal machining conditions
- Normal machining conditions
- Unfavourable machining conditions

SCGX	L	I.C	S	d
09 T3	9.525	9.525	3.97	4.4
12 04	12.7	12.7	4.76	5.56

### Turning inserts

SC** positive insert				HC <sup>1</sup> (CVD)								HC <sup>1</sup> (PVD)			HT	HC <sup>2</sup>	HW											
				<b>P</b>	●	●	●	●	●	●	●	●	●	●	●	●												
				<b>M</b>									●	●	●	●	●	●										
				<b>K</b>																								
				<b>N</b>										●	●				●	●								
				<b>S</b>																●	●							
				<b>H</b>																								
ISO	r	a <sub>p</sub>	f	YBC103	YB6315	YBC152	YBC203	YBC252	YBC352	YBM153	YBM253	YBD102	YB7315	YBD152	YBD152C	YBG101	YBG102	YBG105	YBG205	YB9320	YPD201	YBS103	YNG151	YNT251	YNG151C	YD101	YD201	
LH	<b>SCGX09T302-LH</b>	0.2	0.5-4.0	0.05-0.15												○										●		
 Alum Machining	<b>SCGX09T304-LH</b>	0.4	0.5-4.0	0.1-0.3																						●		
	<b>SCGX09T308-LH</b>	0.8	0.5-4.0	0.15-0.60																							●	
	<b>SCGX120408-LH</b>	0.8	0.5-5.0	0.15-0.60													○										●	

● Ex stock ○ On demand

HC<sup>1</sup> Coated carbide  
 HT Uncoated cermet  
 HC<sup>2</sup> Coated cermet  
 HW Uncoated carbide

Tool holder				
SSBCR/L	SSDCN	SSKCR/L	SSSCR/L	S***-SSKCR/L
Kr: 75°	Kr: 45°	Kr: 75°	Kr: 45°	Kr: 75°
A279	A280	A281	A282	A339

System code > A48

Grade selection > A42

Technical info > A501

Cutting data > A366



**A**

Turning

- Ideal machining conditions
- ⊗ Normal machining conditions
- ⊗ Unfavourable machining conditions

SPMW	L	I.C	S	d
<b>09 T3</b>	9.525	9.525	3.97	4.4
<b>12 04</b>	12.7	12.7	4.76	5.56

## Turning inserts

SP** positive insert				HC <sup>1</sup> (CVD)							HC <sup>1</sup> (PVD)			HT	HC <sup>2</sup>	HW														
	<b>P</b>	●●●●●●●	●●●●●●●	●●●●●								●●	●●	●																
	<b>M</b>			●●	●●	●●	●●	●●	●●	●●	●●	●●																		
	<b>K</b>					●●	●●	●●	●●																					
	<b>N</b>									●●	●●					●●	●●													
	<b>S</b>										●●	●●	●●	●●		●●	●●													
	<b>H</b>																													
	ISO	r	a <sub>p</sub>	f	YBC103	YB6315	YBC152	YBC203	YBC252	YBC352	YBM153	YBM253	YBD102	YB7315	YBD152	YBD152C	YBG101	YBG102	YBG105	YBG205	YB9320	YPD201	YBS103	YNG151	YNT251	YNG151C	YD101	YD201		
Flat	<b>SPMW09T304</b>	0.4	0.5-4.0	0.1-0.4											○															
	<b>SPMW09T308</b>	0.8	0.5-4.0	0.2-0.4												○														
	<b>SPMW120408</b>	0.8	1-6	0.3-0.6												○														

● Ex stock    ○ On demand

HC<sup>1</sup> Coated carbide  
 HT Uncoated cermet  
 HC<sup>2</sup> Coated cermet  
 HW Uncoated carbide

**B**

Milling

**C**

Drilling

**D**

Technical Information

**E**

Index



- Ideal machining conditions
- ⊗ Normal machining conditions
- ⊗ Unfavourable machining conditions

TBGH	L	I.C	S	d
06 01	6.87	3.97	1.59	2.2

**Turning inserts**

TB** positive insert				HC <sup>1</sup> (CVD)								HC <sup>1</sup> (PVD)			HT	HC <sup>2</sup>	HW										
				P	M	K	N	S	H																		
ISO	r	a <sub>p</sub>	f	YBC103	YB6315	YBC152	YBC203	YBC252	YBC352	YBM153	YBM253	YBD102	YB7315	YBD152	YBD152C	YBG101	YBG102	YBG105	YBG205	YB9320	YPD201	YBS103	YNG151	YNT251	YNG151C	YD101	YD201
	<b>TBGH060102L</b>	0.2	0.5-3.5	0.05-0.40												●							●				
	<b>TBGH060104L</b>	0.4	0.5-3.5	0.05-0.40													○							●			

● Ex stock    ○ On demand

HC<sup>1</sup> Coated carbide  
 HT Uncoated cermet  
 HC<sup>2</sup> Coated cermet  
 HW Uncoated carbide

**A**

Turning

**B**

Milling

**C**

Drilling

**D**

Technical Information

**E**

Index

System code > A48

Grade selection > A42

Technical info > A501

Cutting data > A366



**A**

Turning

**B**

Milling

**C**

Drilling

**D**

Technical Information

**E**

Index

- Ideal machining conditions
- ⊗ Normal machining conditions
- ⊗ Unfavourable machining conditions

TCGT	L	I.C	S	d
<b>06 T1</b>	6.87	3.97	1.98	2.2
<b>09 02</b>	9.63	5.56	2.38	2.5
<b>11 03</b>	11	6.35	3.18	2.8

## Turning inserts

TC** positive insert				HC <sup>1</sup> (CVD)										HC <sup>1</sup> (PVD)			HT	HC <sup>2</sup>	HW													
	P	M	K	N	S	H	YBC103	YB6315	YBC152	YBC203	YBC252	YBC352	YBM153	YBM253	YBD102	YB7315	YBD152	YBD152C	YBG101	YBG102	YBG105	YBG205	YB9320	YPD201	YBS103	YNG151	YNT251	YNG151C	YD101	YD201		
	ISO	r	a <sub>p</sub>	f																												
		<b>TCGT06T102-SF</b>	0.2	0.05-2.00	0.05-0.15																											
		<b>TCGT090202-SF</b>	0.2	0.05-2.00	0.05-0.15																							○	○			
		<b>TCGT090204-SF</b>	0.4	0.05-2.00	0.1-0.3																											
		<b>TCGT090208-SF</b>	0.8	0.05-2.00	0.10-0.35																											
<b>TCGT110302-SF</b>		0.2	0.05-2.00	0.05-0.15																												
<b>TCGT110304-SF</b>		0.4	0.05-2.00	0.1-0.3																								●	●			
<b>TCGT110308-SF</b>		0.8	0.05-2.00	0.10-0.35																												

● Ex stock    ○ On demand

- HC<sup>1</sup> Coated carbide
- HT Uncoated cermet
- HC<sup>2</sup> Coated cermet
- HW Uncoated carbide

Tool holder	
<b>STGCR/L</b> Kr: 91°	<b>E***-STFCR/L</b> Kr: 90°
A285	A361



TCMT	L	I.C	S	d
09 02	9.63	5.56	2.38	2.5
11 02	11	6.35	2.38	2.8
16 T3	16.5	9.525	3.97	4.4

- Ideal machining conditions
- ⊗ Normal machining conditions
- ⊗ Unfavourable machining conditions

**Turning inserts**

TC** positive insert				HC <sup>1</sup> (CVD)								HC <sup>1</sup> (PVD)			HT	HC <sup>2</sup>	HW												
				P	M	K	N	S	H																				
ISO	r	a <sub>p</sub>	f	YBC103	YB6315	YBC152	YBC203	YBC252	YBC352	YBM153	YBM253	YBD102	YBD315	YBD152	YBD152C	YBG101	YBG102	YBG105	YBG205	YB9320	YPD201	YBS103	YNG151	YNT251	YNG151C	YD101	YD201		
<b>AHF</b>  Finishing	<b>TCMT110204-AHF</b>	0.4	0.2-2.5	0.05-0.30	●	●	●	●	●																				
	<b>TCMT110208-AHF</b>	0.8	0.2-2.5	0.1-0.4	●	●	●	●	●																				
	<b>TCMT16T304-AHF</b>	0.4	0.5-3.0	0.05-0.30	●	●	●	●	●																				
	<b>TCMT16T308-AHF</b>	0.8	0.5-3.5	0.1-0.4	●	●	●	●	●																				
<b>HF</b>  Finishing	<b>TCMT090202-HF</b>	0.2	0.06-1.70	0.03-0.13		○	●																○						
	<b>TCMT090204-HF</b>	0.4	0.1-1.7	0.05-0.19		○	●																						
	<b>TCMT090208-HF</b>	0.8	0.15-1.70	0.10-0.25				○																					
	<b>TCMT110202-HF</b>	0.2	0.08-2.00	0.05-0.20					●																				
	<b>TCMT110204-HF</b>	0.4	0.1-2.0	0.05-0.30		○	●							○															
	<b>TCMT110208-HF</b>	0.8	0.1-2.0	0.05-0.35		●	●					●																	
	<b>TCMT16T304-HF</b>	0.4	0.11-2.00	0.05-0.23		○	●																						
<b>XF</b>  Finishing	<b>TCMT090202-XF</b>	0.2	0.5-1.5	0.08-0.15				○																					
	<b>TCMT090204-XF</b>	0.4	0.5-1.5	0.08-0.20	●																								
	<b>TCMT110202-XF</b>	0.2	0.5-2.0	0.08-0.15				○																					
	<b>TCMT110204-XF</b>	0.4	0.5-2.0	0.08-0.20	●																								
	<b>TCMT110208-XF</b>	0.8	0.5-2.5	0.08-0.25	●																								
	<b>TCMT16T304-XF</b>	0.4	0.5-2.5	0.08-0.20	●																								
<b>TCMT16T308-XF</b>	0.8	0.5-2.5	0.08-0.25	●																									

● Ex stock ○ On demand  
 YBC152F, YBC252F, YBM153F, YBM253F available

HC<sup>1</sup> Coated carbide  
 HT Uncoated cermet  
 HC<sup>2</sup> Coated cermet  
 HW Uncoated carbide

Tool holder					
STACR/L	STFCR/L	STGCR/L	STTCR/L	S***-STFCR/L	E***-STFCR/L
Kr: 90°	Kr: 91°	Kr: 91°	Kr: 60°	Kr: 91°	Kr: 90°
A283	A284	A285	A286	A341	A361

System code > A48

Grade selection > A42

Technical info > A501

Cutting data > A366



**A** Turning  
**B** Milling  
**C** Drilling  
**D** Technical Information  
**E** Index

**A**

Turning

**B**

Milling

**C**

Drilling

**D**

Technical Information

**E**

Index

- Ideal machining conditions
- ● Normal machining conditions
- ● ● Unfavourable machining conditions

TCMT	L	I.C	S	d
<b>09 02</b>	9.63	5.56	2.38	2.5
<b>11 02</b>	11	6.35	2.38	2.8
<b>16 T3</b>	16.5	9.525	3.97	4.4

## Turning inserts

TC** positive insert				HC <sup>1</sup> (CVD)								HC <sup>1</sup> (PVD)		HT	HC <sup>2</sup>	HW														
	P	M	K	N	S	H	YBC103	YB6315	YBC152	YBC203	YBC252	YBC352	YBM153	YBM253	YBD102	YB7315	YBD152	YBD152C	YBG101	YBG102	YBG105	YBG205	YB9320	YPD201	YBS103	YNG151	YNT251	YNG151C	YD101	YD201
	ISO	r	a <sub>p</sub>	f																										
	 Finishing	<b>TCMT090202-EF</b>	0.2	0.06-1.70	0.03-0.13																									
		<b>TCMT090204-EF</b>	0.4	0.1-1.7	0.05-0.19																									
		<b>TCMT110202-EF</b>	0.2	0.2-2.0	0.05-0.13																									
		<b>TCMT110204-EF</b>	0.4	0.2-2.0	0.05-0.20																									
<b>TCMT16T304-EF</b>		0.4	0.3-3.0	0.05-0.23																										
<b>TCMT16T308-EF</b>		0.8	0.3-3.0	0.1-0.4																										
 Medium Cut	<b>TCMT090204-EM</b>	0.4	0.19-2.25	0.06-0.17																										
	<b>TCMT110204-EM</b>	0.4	0.2-2.7	0.05-0.30																										
	<b>TCMT110208-EM</b>	0.8	0.8-2.7	0.08-0.30																										
	<b>TCMT16T304-EM</b>	0.4	0.25-3.00	0.08-0.23																										
	<b>TCMT16T308-EM</b>	0.8	0.5-3.0	0.1-0.3																										
 Medium Cut	<b>TCMT16T304-XM</b>	0.4	1-3.0	0.15-0.3	○	○																								
	<b>TCMT16T308-XM</b>	0.8	1-3.0	0.15-0.35	○	○																								
	<b>TCMT16T312-XM</b>	1.2	1-3.0	0.15-0.4	○	○																								

● Ex stock   ○ On demand  
 YBC152F, YBC252F, YBM153F, YBM253F available

HC<sup>1</sup> Coated carbide  
 HT Uncoated cermet  
 HC<sup>2</sup> Coated cermet  
 HW Uncoated carbide

### Tool holder

STACR/L	STFCR/L	STGCR/L	STTCR/L	S***-STFCR/L	E***-STFCR/L
Kr: 90°	Kr: 91°	Kr: 91°	Kr: 60°	Kr: 91°	Kr: 90°
A283	A284	A285	A286	A341	A361

System code > A48

Grade selection > A42

Technical info > A501

Cutting data > A366

TC**	L	I.C	S	d
09 02	9.63	5.56	2.38	2.5
11 02	11	6.35	2.38	2.8
16 T3	16.5	9.525	3.97	4.4
22 04	22	12.7	4.76	5.5

- Ideal machining conditions
- ⊗ Normal machining conditions
- ⊗ Unfavourable machining conditions

**Turning inserts**

TC** positive insert					HC <sup>1</sup> (CVD)								HC <sup>1</sup> (PVD)			HT	HC <sup>2</sup>	HW
					P	●	●	●	●	●	●	●	●	●	●	●	●	●
					M	●	●	●	●	●	●	●	●	●	●	●	●	●
					K	●	●	●	●	●	●	●	●	●	●	●		
					N	●	●	●	●	●	●	●	●	●	●	●	●	
					S	●	●	●	●	●	●	●	●	●	●	●	●	
					H	●	●	●	●	●	●	●	●	●	●	●	●	
ISO	r	a <sub>p</sub>	f		YBC103	YBC103	YBC103	YBC103	YBC103	YBC103	YBC103	YBC103	YBC103	YBC103	YBC103	YBC103	YBC103	
Flat  Medium Cut	<b>TCMW16T308</b>				0.8	0.5-5.0	0.05-0.60											
	HM  Medium Cut	<b>TCMT090204-HM</b>				0.4	0.19-2.25	0.06-0.17	●	●	●	●						
<b>TCMT090208-HM</b>				0.8	0.38-2.25	0.08-0.23	○	○			○							
<b>TCMT110204-HM</b>				0.4	0.2-2.7	0.07-0.20	●	●	●	●								
<b>TCMT110208-HM</b>				0.8	0.5-2.7	0.1-0.3	●	●	●	●								
<b>TCMT16T304-HM</b>				0.4	0.25-3.00	0.08-0.23	●	●	●	●								
<b>TCMT16T308-HM</b>				0.8	0.5-3.0	0.1-0.3	●	●	●	●								
<b>TCMT16T312-HM</b>				1.2	0.6-3.0	0.12-0.36	○	●										
HR  Roughing	<b>TCMT090204-HR</b>				0.4	0.5-3.0	0.1-0.3			○								
	<b>TCMT090208-HR</b>				0.8	0.5-3.5	0.08-0.50			○								
	<b>TCMT110204-HR</b>				0.4	0.5-3.0	0.1-0.4		●									
	<b>TCMT110208-HR</b>				0.8	1-4	0.1-0.5		●									
	<b>TCMT16T304-HR</b>				0.4	0.5-4.0	0.1-0.4		●	●								
	<b>TCMT16T308-HR</b>				0.8	1-4	0.12-0.35		●	●	●							
	<b>TCMT16T312-HR</b>				1.2	1.2-4.0	0.14-0.42	○		○	●							
<b>TCMT220408-HR</b>				0.8	1.2-4.8	0.14-0.42	○	●		●								

● Ex stock ○ On demand  
YBC152F, YBC252F, YBM153F, YBM253F available

HC<sup>1</sup> Coated carbide  
HT Uncoated cermet  
HC<sup>2</sup> Coated cermet  
HW Uncoated carbide

Tool holder					
STACR/L	STFCR/L	STGCR/L	STTCR/L	S***-STFCR/L	E***-STFCR/L
Kr: 90°	Kr: 91°	Kr: 91°	Kr: 60°	Kr: 91°	Kr: 90°
A283	A284	A285	A286	A341	A361

System code > A48

Grade selection > A42

Technical info > A501

Cutting data > A366



A

Turning

B

Milling

C

Drilling

D

Technical Information

E

Index



**A**

Turning

- Ideal machining conditions
- ⊗ Normal machining conditions
- ⊗ Unfavourable machining conditions

TCMT	L	I.C	S	d
22 04	22	12.7	4.76	5.5

## Turning inserts

TC** positive insert				HC <sup>1</sup> (CVD)								HC <sup>1</sup> (PVD)			HT	HC <sup>2</sup>	HW											
	<b>P</b>	●●●●	⊗⊗⊗										●●	⊗	●													
	<b>M</b>			●	⊗						●●	⊗⊗⊗	●●	⊗	●													
	<b>K</b>								●●●●																			
	<b>N</b>										●●					●●												
	<b>S</b>										●●	⊗⊗⊗	●●			●●												
	<b>H</b>																											
ISO	r	a <sub>p</sub>	f	YBC103	YB6315	YBC152	YBC203	YBC252	YBC352	YBM153	YBM253	YBD102	YB7315	YBD152	YBD152C	YBG101	YBG102	YBG105	YBG205	YB9320	YPD201	YBS103	YNG151	YNT251	YNG151C	YD101	YD201	
Basic	<b>TCMT220408</b>	0.8	1.2-4.8	0.14-0.42								●																

● Ex stock    ○ On demand

HC<sup>1</sup> Coated carbide  
 HT Uncoated cermet  
 HC<sup>2</sup> Coated cermet  
 HW Uncoated carbide

**B**

Milling

**C**

Drilling

**D**

Technical Information

**E**

Index



TCGX	L	I.C	S	d
09 02	9.63	5.56	2.38	2.5
11 02	11	6.35	2.38	2.8
16 T3	16.5	9.525	3.97	4.4

- Ideal machining conditions
- ⊗ Normal machining conditions
- ⊗ Unfavourable machining conditions

**Turning inserts**

TC** positive insert				HC <sup>1</sup> (CVD)								HC <sup>1</sup> (PVD)		HT	HC <sup>2</sup>	HW												
				P	●	●	●	●	●	●	●	●	●	●	●													
				M	●	●	●	●	●	●	●	●	●	●	●													
				K																								
				N						●	●				●	●												
				S						●	●	●	●	●	●	●												
				H																								
ISO	r	a <sub>p</sub>	f	YBC103	YB6315	YBC152	YBC203	YBC252	YBC352	YBM153	YBM253	YBD102	YB7315	YBD152	YBD152C	YBG101	YBG102	YBG105	YBG205	YB9320	YPD201	YBS103	YNG151	YNT251	YNG151C	YD101	YD201	
 Alum Machining	TCGX090202-LC	0.2	0.3-4.0	0.05-0.15												●												●
	TCGX090204-LC	0.4	0.5-4.0	0.1-0.3													●											●
	TCGX110202-LC	0.2	0.3-5.0	0.05-0.15													●											●
	TCGX110204-LC	0.4	0.5-5.0	0.1-0.3													●											●
	TCGX110208-LC	0.8	0.5-5.0	0.15-0.60													●											●
	TCGX16T304-LC	0.4	0.5-7.0	0.1-0.3																								●
	TCGX16T308-LC	0.8	0.5-7.0	0.15-0.60													●											●
 Alum Machining	TCGX090202-LH	0.2	0.3-4.0	0.05-0.15													○										●	
	TCGX090204-LH	0.4	0.5-4.0	0.1-0.3														○										●
	TCGX110202-LH	0.2	0.3-5.0	0.05-0.15														○										●
	TCGX110204-LH	0.4	0.5-5.0	0.1-0.3														●										●
	TCGX110208-LH	0.8	0.5-5.0	0.15-0.60																								●
	TCGX16T302-LH	0.2	0.5-7.0	0.05-0.15														○										●
	TCGX16T304-LH	0.4	0.5-7.0	0.1-0.3														○										●
TCGX16T308-LH	0.8	0.5-7.0	0.15-0.60														○										●	

● Ex stock ○ On demand

HC<sup>1</sup> Coated carbide  
 HT Uncoated cermet  
 HC<sup>2</sup> Coated cermet  
 HW Uncoated carbide

Tool holder					
STACR/L	STFCR/L	STGCR/L	STTCR/L	S***-STFCR/L	E***-STFCR/L
Kr: 90°	Kr: 91°	Kr: 91°	Kr: 60°	Kr: 91°	Kr: 90°
A283	A284	A285	A286	A341	A361

System code > A48

Grade selection > A42

Technical info > A501

Cutting data > A366



**A** Turning  
**B** Milling  
**C** Drilling  
**D** Technical Information  
**E** Index

**A**

Turning

- Ideal machining conditions
- ⊗ Normal machining conditions
- ⊗ Unfavourable machining conditions

TPGH	L	I.C	S	d
09 02	9.63	5.56	2.38	2.8
11 03	11	6.35	3.18	3.18

## Turning inserts

TP** positive insert				HC <sup>1</sup> (CVD)										HC <sup>1</sup> (PVD)		HT	HC <sup>2</sup>	HW												
	P	M	K	N	S	H																								
	ISO	r	a <sub>p</sub>	f	YBC103	YB6315	YBC152	YBC203	YBC252	YBC352	YBM153	YBM253	YBD102	YB7315	YBD152	YBD152C	YBG101	YBG102	YBG105	YBG205	YB9320	YPD201	YBS103	YNG151	YNT251	YNG151C	YD101	YD201		
	 Super Finishing	TPGH090202L	0.2	0.2-3.0	0.05-0.15													●								●	●			
		TPGH090204L	0.4	0.2-3.0	0.05-0.30														●								●	●		
		TPGH110302L	0.2	0.2-3.5	0.05-0.15														●								●	●		
		TPGH110304L	0.4	0.2-3.5	0.05-0.30														●								●	●		

● Ex stock    ○ On demand

HC<sup>1</sup> Coated carbide  
 HT Uncoated cermet  
 HC<sup>2</sup> Coated cermet  
 HW Uncoated carbide

**B**

Milling

**C**

Drilling

**D**

Technical Information

**E**

Index



**Turning inserts**



- Ideal machining conditions
- Normal machining conditions
- Unfavourable machining conditions

TPGT	L	I.C	S	d
09 02	9.63	5.56	2.38	2.5
11 03	11	6.35	3.18	2.8

TP** positive insert				HC <sup>1</sup> (CVD)								HC <sup>1</sup> (PVD)		HT	HC <sup>2</sup>	HW	
ISO	r	a <sub>p</sub>	f	P	M	K	N	S	H								
				TPGT090202-SF	0.2	0.05-2.00	0.05-0.15	●●●●●●●●●●						●●●●●●●●●●	●●●●●●●●●●	●●●●●●●●●●	
TPGT090204-SF	0.4	0.05-2.00	0.05-0.25		●●●●●●●●●●					●●●●●●●●●●	●●●●●●●●●●	●●●●●●●●●●					
TPGT090208-SF	0.8	0.05-2.00	0.05-0.35			●●●●●●●●●●											
TPGT110302-SF	0.2	0.05-2.00	0.05-0.15				●●●●●●●●●●			●●●●●●●●●●				●●●●●●●●●●			
TPGT110304-SF	0.4	0.05-2.00	0.05-0.25					●●●●●●●●●●		●●●●●●●●●●				●●●●●●●●●●			
TPGT110308-SF	0.8	0.05-2.00	0.05-0.35								●●●●●●●●●●			●●●●●●●●●●			

● Ex stock ○ On demand

HC<sup>1</sup> Coated carbide  
 HT Uncoated cermet  
 HC<sup>2</sup> Coated cermet  
 HW Uncoated carbide

Tool holder		
S***-STUPR/L	C***-STUPR/L	E***-STFPR/L
Kr: 93°	Kr: 93°	Kr: 90°
		
A351	A360	A362



**A**

Turning

**B**

Milling

**C**

Drilling

**D**

Technical Information

**E**

Index

- Ideal machining conditions
- ● Normal machining conditions
- ● ● Unfavourable machining conditions

VBMT	L	I.C	S	d
11 02	11	6.35	2.38	2.8
11 03	11	6.35	3.18	2.8
16 04	16.5	9.525	4.76	4.4

## Turning inserts

VB** positive insert					HC <sup>1</sup> (CVD)										HC <sup>1</sup> (PVD)			HT	HC <sup>2</sup>	HW											
					P	M	K	N	S	H																					
ISO					r	a <sub>p</sub>	f	YBC103	YB6315	YBC152	YBC203	YBC252	YBC352	YBM153	YBM253	YBD102	YB7315	YBD152	YBD152C	YBG101	YBG102	YBG105	YBG205	YB9320	YPD201	YBS103	YNG151	YNT251	YNG151C	YD101	YD201
AHF	<b>VBMT160404-AHF</b>	0.4	0.2-3.0	0.05-0.30	●																										
	<b>VBMT160408-AHF</b>	0.8	0.8-3.5	0.08-0.40	●																										
Finishing																															
EF	<b>VBMT110302-EF</b>	0.2	0.06-1.70	0.03-0.13																			●								
	<b>VBMT110304-EF</b>	0.4	0.1-1.7	0.05-0.19										●									●								
Finishing	<b>VBMT110308-EF</b>	0.8	0.13-1.70	0.07-0.26										●								○									
	<b>VBMT160404-EF</b>	0.4	0.1-1.8	0.05-0.20										●									●								
	<b>VBMT160408-EF</b>	0.8	0.14-1.80	0.07-0.27										●									●								
XF	<b>VBMT110202-XF</b>	0.2	0.5-2.0	0.08-0.20							○																				
	<b>VBMT110204-XF</b>	0.4	0.5-2.0	0.08-0.20	●																										
Finishing	<b>VBMT110302-XF</b>	0.2	0.5-2.0	0.08-0.20							○																				
	<b>VBMT110304-XF</b>	0.4	0.5-2.0	0.08-0.20	●																										
	<b>VBMT160404-XF</b>	0.4	0.5-2.5	0.08-0.20	●																										
	<b>VBMT160408-XF</b>	0.8	0.5-2.5	0.08-0.25	●																										

● Ex stock   ○ On demand  
 YBC152F, YBC252F, YBM153F, YBM253F available

HC<sup>1</sup> Coated carbide  
 HT Uncoated cermet  
 HC<sup>2</sup> Coated cermet  
 HW Uncoated carbide

Tool holder					
SVJBR/L	SVABR/L	SVVBN	S***-SVQBR/L	S***-SVUBR/L	S***-SVXBR/L
Kr: 93°	Kr: 90°	Kr: 72°30'	Kr: 107°30'	Kr: 93°	Kr: 93°
A274	A275	A276	A345	A346	A347



- Ideal machining conditions
- Normal machining conditions
- Unfavourable machining conditions

VB**	L	I.C	S	d
11 02	11	6.35	2.38	2.8
16 04	16.5	9.525	4.76	4.4

**Turning inserts**

VB** positive insert				HC <sup>1</sup> (CVD)								HC <sup>1</sup> (PVD)		HT	HC <sup>2</sup>	HW												
				<b>P</b>	●●●●●●●●●●								●●●●	●●●●	●●													
				<b>M</b>			●●●●							●●●●●●●●	●●●●	●●												
				<b>K</b>				●●●●																				
				<b>N</b>										●●				●●●●	●●									
				<b>S</b>										●●●●●●●●				●●●●	●●									
				<b>H</b>																								
ISO	r	a <sub>p</sub>	f	YBC103	YB6315	YBC152	YBC203	YBC252	YBC352	YBM153	YBM253	YBD102	YB7315	YBD152	YBD152C	YBG101	YBG102	YBG105	YBG205	YB9320	YPD201	YBS103	YNG151	YNT251	YNG151C	YD101	YD201	
HF	<b>VBMT110202-HF</b>	0.2	0.2-2.0	0.05-0.15																								
	<b>VBMT110204-HF</b>	0.4	0.2-2.0	0.05-0.35																								
	<b>VBMT110208-HF</b>	0.8	0.2-2.0	0.05-0.40																								
Finishing																												
NF	<b>VBET160404-NF</b>	0.4	0.2-3.0	0.05-0.30													○ ●											
	<b>VBET160408-NF</b>	0.8	0.2-3.0	0.08-0.40													○ ●											
Finishing																												

● Ex stock ○ On demand

HC<sup>1</sup> Coated carbide  
 HT Uncoated cermet  
 HC<sup>2</sup> Coated cermet  
 HW Uncoated carbide

Tool holder					
SVJBR/L	SVABR/L	SVVBN	S***-SVQBR/L	S***-SVUBR/L	S***-SVXBR/L
Kr: 93°	Kr: 90°	Kr: 72°30'	Kr: 107°30'	Kr: 93°	Kr: 93°
A274	A275	A276	A345	A346	A347



**A** Turning  
**B** Milling  
**C** Drilling  
**D** Technical Information  
**E** Index

**A**

Turning

- Ideal machining conditions
- ⊗ Normal machining conditions
- ⊗ Unfavourable machining conditions

VBGT	L	I.C	S	d
11 03	11	6.35	3.18	2.8

## Turning inserts

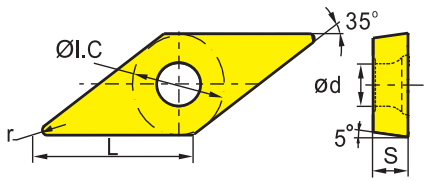
VB** positive insert				HC <sup>1</sup> (CVD)								HC <sup>1</sup> (PVD)			HT	HC <sup>2</sup>	HW												
				<b>P</b>	●	●	●	●	●	●	●	●	●	●	●	●	●												
				<b>M</b>						●	●			●	●	●	●	●	●										
				<b>K</b>										●	●	●	●	●	●										
				<b>N</b>										●	●					●	●								
				<b>S</b>												●	●	●	●	●	●								
				<b>H</b>																									
	ISO	r	a <sub>p</sub>	f	YBC103	YB6315	YBC152	YBC203	YBC252	YBC352	YBM153	YBM253	YBD102	YB7315	YBD152	YBD152C	YBG101	YBG102	YBG105	YBG205	YB9320	YPD201	YBS103	YNG151	YNT251	YNG151C	YD101	YD201	
SF	<b>VBGT110302-SF</b>	0.2	0.05-2.00	0.05-0.15																					○	○	●		
	<b>VBGT110304-SF</b>	0.4	0.05-2.00	0.05-0.20																						○	●		
Finishing																													

● Ex stock    ○ On demand



HC<sup>1</sup> Coated carbide  
 HT Uncoated cermet  
 HC<sup>2</sup> Coated cermet  
 HW Uncoated carbide

**B**

Milling

**C**

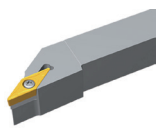
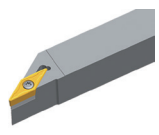
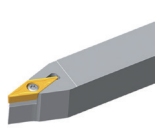
Drilling

Tool holder			
<b>SVJBR/L</b>	<b>SVABR/L</b>	<b>SVVBN</b>	<b>S***-SVXBR/L</b>
Kr: 93°	Kr: 90°	Kr: 72°30'	Kr: 93°
			
A274	A275	A276	A347

**D**

Technical Information

**E**

Index

System code > A48

Grade selection > A42

Technical info > A501

Cutting data > A366

**Turning inserts**

- Ideal machining conditions
- Normal machining conditions
- Unfavourable machining conditions

VB**	L	I.C	S	d
11 03	11	6.35	3.18	2.8
16 04	16.5	9.525	4.76	4.4

VB** positive insert				HC <sup>1</sup> (CVD)								HC <sup>1</sup> (PVD)			HT	HC <sup>2</sup>	HW										
				P	M	K	N	S	H																		
ISO	r	a <sub>p</sub>	f	YBC103	YB6315	YBC152	YBC203	YBC252	YBC352	YBM153	YBM253	YBD102	YB7315	YBD152	YBD152C	YBG101	YBG102	YBG105	YBG205	YB9320	YPD201	YBS103	YNG151	YNT251	YNG151C	YD101	YD201
NGF	<b>VBET160408-NGF</b>	0.8	0.2-3.0	0.08-0.30														●									
	<b>VBET160412-NGF</b>	1.2	0.2-3.0	0.1-0.4														●									
Finishing																											
EM	<b>VBMT110304-EM</b>	0.4	0.15-2.00	0.07-0.20						●								●									
	<b>VBMT110308-EM</b>	0.8	0.2-2.0	0.09-0.27		○				●								●									
	<b>VBMT160404-EM</b>	0.4	0.23-2.70	0.07-0.20						●								●									
	<b>VBMT160408-EM</b>	0.8	0.45-2.70	0.09-0.27						●								●									
Medium Cut																											
HM	<b>VBMT160404-HM</b>	0.4	0.23-2.70	0.07-0.20		●	●			●																	
	<b>VBMT160408-HM</b>	0.8	0.45-2.70	0.09-0.27		●	●			●	●																○
	<b>VBMT160412-HM</b>	1.2	0.54-2.70	0.11-0.32		●	●																				
Medium Cut																											
XM	<b>VBMT160404-XM</b>	0.4	1-2.5	0.15-0.25	●	○																					
	<b>VBMT160408-XM</b>	0.8	1-2.5	0.15-0.3	●	○																					
	<b>VBMT160412-XM</b>	1.2	1-2.5	0.15-0.35	●	○																					
Medium Cut																											

● Ex stock ○ On demand  
 YBC152F, YBC252F, YBM153F, YBM253F available

HC<sup>1</sup> Coated carbide  
 HT Uncoated cermet  
 HC<sup>2</sup> Coated cermet  
 HW Uncoated carbide

Tool holder					
SVJBR/L	SVABR/L	SVVBN	S***-SVQBR/L	S***-SVUBR/L	S***-SVXBR/L
Kr: 93°	Kr: 90°	Kr: 72°30'	Kr: 107°30'	Kr: 93°	Kr: 93°
A274	A275	A276	A345	A346	A347

System code > A48

Grade selection > A42

Technical info > A501

Cutting data > A366





**A**

Turning

- Ideal machining conditions
- ⊗ Normal machining conditions
- ⊗ Unfavourable machining conditions

VBMT	L	I.C	S	d
16 04	16.5	9.525	4.76	4.4

## Turning inserts

VB** positive insert					HC <sup>1</sup> (CVD)										HC <sup>1</sup> (PVD)		HT	HC <sup>2</sup>	HW										
					P	●	●	●	●	●	●	●	●	●	●	●	●	●	●	●	●	●	●						
					M	●	●	●	●	●	●	●	●	●	●	●	●	●	●	●	●	●	●	●					
					K	●	●	●	●	●	●	●	●	●	●	●	●	●	●	●	●	●	●	●	●				
					N	●	●	●	●	●	●	●	●	●	●	●	●	●	●	●	●	●	●	●	●				
					S	●	●	●	●	●	●	●	●	●	●	●	●	●	●	●	●	●	●	●	●				
					H	●	●	●	●	●	●	●	●	●	●	●	●	●	●	●	●	●	●	●	●				
ISO	r	a <sub>p</sub>	f		YBC103	YB6315	YBC152	YBC203	YBC252	YBC352	YBM153	YBM253	YBD102	YB7315	YBD152	YBD152C	YBG101	YBG102	YBG105	YBG205	YB9320	YPD201	YBS103	YNG151	YNT251	YNG151C	YD101	YD201	
HR 	<b>VBMT160404-HR</b>	0.4	0.5-3.0	0.1-0.3	●	●																							
	<b>VBMT160408-HR</b>	0.8	0.9-3.6	0.11-0.32	○	●																							
	<b>VBMT160412-HR</b>	1.2	1.08-3.60	0.13-0.38	○	●																							
SNR 	<b>VBMT160408-SNR</b>	0.8	0.5-4.0	0.1-0.3														●				○							
	<b>VBMT160412-SNR</b>	1.2	0.5-4.0	0.3-0.6														●				○	○						

● Ex stock   ○ On demand  
 YBC152F, YBC252F, YBM153F, YBM253F available

HC<sup>1</sup> Coated carbide  
 HT Uncoated cermet  
 HC<sup>2</sup> Coated cermet  
 HW Uncoated carbide

**B**

Milling

**C**

Drilling

**D**

Technical Information

**E**

Index

Tool holder					
SVJBR/L	SVABR/L	SVVBN	S***-SVQBR/L	S***-SVUBR/L	S***-SVXBR/L
Kr: 93°	Kr: 90°	Kr: 72°30'	Kr: 107°30'	Kr: 93°	Kr: 93°
A274	A275	A276	A345	A346	A347

System code > A48

Grade selection > A42

Technical info > A501

Cutting data > A366

**Turning inserts**

- Ideal machining conditions
- Normal machining conditions
- Unfavourable machining conditions

VC GT	L	I.C	S	d
11 03	11	6.35	3.18	2.8
16 04	16.5	9.525	4.76	4.4

VC** positive insert				HC <sup>1</sup> (CVD)								HC <sup>1</sup> (PVD)			HT	HC <sup>2</sup>	HW																														
				P	M	K	N	S	H																																						
				<table border="1"> <thead> <tr> <th>ISO</th> <th>r</th> <th>a<sub>p</sub></th> <th>f</th> <th>YBC103</th> <th>YB6315</th> <th>YBC152</th> <th>YBC203</th> <th>YBC252</th> <th>YBC352</th> <th>YBM153</th> <th>YBM253</th> <th>YBD102</th> <th>YB7315</th> <th>YBD152</th> <th>YBD152C</th> <th>YBG101</th> <th>YBG102</th> <th>YBG105</th> <th>YBG205</th> <th>YB9320</th> <th>YPD201</th> <th>YBS103</th> <th>YNG151</th> <th>YNT251</th> <th>YNG151C</th> <th>YD101</th> <th>YD201</th> </tr> </thead> </table>																ISO	r	a <sub>p</sub>	f	YBC103	YB6315	YBC152	YBC203	YBC252	YBC352	YBM153	YBM253	YBD102	YB7315	YBD152	YBD152C	YBG101	YBG102	YBG105	YBG205	YB9320	YPD201	YBS103	YNG151	YNT251	YNG151C	YD101	YD201
ISO	r	a <sub>p</sub>	f	YBC103	YB6315	YBC152	YBC203	YBC252	YBC352	YBM153	YBM253	YBD102	YB7315	YBD152	YBD152C	YBG101	YBG102	YBG105	YBG205	YB9320	YPD201	YBS103	YNG151	YNT251	YNG151C	YD101	YD201																				
HF	<b>VC GT110304-HF</b>	0.4	0.2-2.0	0.05-0.30																																											
Finishing																																															
NF	<b>VC GT160408-NF</b>	0.8	0.2-2.0	0.1-0.4																																											
Finishing																																															
SF	<b>VC GT110302-SF</b>	0.2	0.05-1.00	0.05-0.15																																											
Finishing	<b>VC GT110304-SF</b>	0.4	0.05-1.00	0.05-0.25																																											
	<b>VC GT160404-SF</b>	0.4	0.05-1.50	0.05-0.25																																											

● Ex stock ○ On demand

HC<sup>1</sup> Coated carbide  
 HT Uncoated cermet  
 HC<sup>2</sup> Coated cermet  
 HW Uncoated carbide

Tool holder						
SVVCN	SVJCR/L	SVACR/L-SC	SVJCR/L-SC	S***-SVQCR/L	S***-SVUCR/L	C***-SVQCR/L
Kr: 72°30'	Kr: 93°	Kr: 90°	Kr: 93°	Kr: 107°30'	Kr: 93°	Kr: 107°30'
A277	A278	A312	A313	A343	A344	A363

C***-SVUCR/L
Kr: 93°
A364

System code > A48

Grade selection > A42

Technical info > A501

Cutting data > A366



A

Turning

B

Milling

C

Drilling

D

Technical Information

E

Index

VCGX	L	I.C	S	d
11 03	11	6.35	3.18	2.8
16 04	16.6	9.525	4.76	4.4
22 05	22	12.7	5.56	5.5

- Ideal machining conditions
- Normal machining conditions
- Unfavourable machining conditions

## Turning/Milling inserts

VC** turning/milling insert				HC <sup>1</sup> (CVD)								HC <sup>1</sup> (PVD)			HT	HC <sup>2</sup>	HW							
				P	M	K	N	S	H	YBC103	YBG101	YBG102	YBG105	YBG205	YB9320	YPD201	YBS103	YNG151	YNT251	YNG151C	YD101	YD201		
ISO	r	a <sub>p</sub>	f																					
LC	<b>VCGX110301-LC</b>	0.1	0.3-3.0	0.05-0.10																				
	<b>VCGX110302-LC</b>	0.2	0.3-3.0	0.05-0.15																				
	<b>VCGX110304-LC</b>	0.4	0.5-3.0	0.1-0.3																				
	<b>VCGX110308-LC</b>	0.8	1-3	0.1-0.5																				
Alum Machining	<b>VCGX160404-LC</b>	0.4	0.5-5.0	0.1-0.3																				
	<b>VCGX160408-LC</b>	0.8	0.5-5.0	0.15-0.60																				
	<b>VCGX160412-LC</b>	1.2	0.5-5.0	0.15-0.80																				
	<b>VCGX220530-LC</b>	3	0.5-7.0	0.25-1.00																				

● Ex stock    ○ On demand

HC<sup>1</sup> Coated carbide  
 HT Uncoated cermet  
 HC<sup>2</sup> Coated cermet  
 HW Uncoated carbide

Tool holder						
SVVCN	SVJCR/L	SVACR/L-SC	SVJCR/L-SC	S***-SVQCR/L	S***-SVUCR/L	C***-SVQCR/L
Kr: 72°30'	Kr: 93°	Kr: 90°	Kr: 93°	Kr: 107°30'	Kr: 93°	Kr: 107°30'
A277	A278	A312	A313	A343	A344	A363

C\*\*\*-SVUCR/L

Kr: 93°

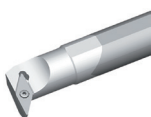

A364

System code > A48

Grade selection > A42

Technical info > A501

Cutting data > A366

VCGX	L	I.C	S	d
11 02	11	6.35	2.38	2.8
11 03	11	6.35	3.18	2.8
16 04	16.6	9.525	4.76	4.4
22 05	22	12.7	5.56	5.5

- Ideal machining conditions
- Normal machining conditions
- Unfavourable machining conditions

**Turning/Milling inserts**

VC** turning/milling insert				HC <sup>1</sup> (CVD)								HC <sup>1</sup> (PVD)			HT	HC <sup>2</sup>	HW																			
ISO	r	a <sub>p</sub>	f	P	M	K	N	S	H	YBC103	YB6315	YBC152	YBC203	YBC252	YBC352	YBM153	YBM253	YBD102	YB7315	YBD152	YBD152C	YBG101	YBG102	YBG105	YBG205	YB9320	YPD201	YBS103	YNG151	YNT251	YNG151C	YD101	YD201			
				LH	VCGX110204-LH	0.4	0.5-3.0	0.1-0.3	●	●	●	●	●	●	●	●	●	●	●	●	●	●	●	●	●	●	●	●	●	●	●	●	●	●	●	●
Alum Machining	VCGX110301-LH	0.1	0.5-3.0	0.05-0.10																																
	VCGX110302-LH	0.2	0.3-3.0	0.05-0.15																																
	VCGX110304-LH	0.4	0.5-3.0	0.1-0.3																																
	VCGX110308-LH	0.8	0.5-3.0	0.15-0.60																																
	VCGX160402-LH	0.2	0.5-5.0	0.05-0.10																																
	VCGX160404-LH	0.4	0.5-5.0	0.1-0.3																																
	VCGX160408-LH	0.8	0.5-5.0	0.15-0.60																																
	VCGX160412-LH	1.2	0.5-5.0	0.15-0.80																																
	VCGX220530-LH	3	0.5-7.0	0.25-1.00																																

● Ex stock ○ On demand

HC<sup>1</sup> Coated carbide  
 HT Uncoated cermet  
 HC<sup>2</sup> Coated cermet  
 HW Uncoated carbide

Tool holder						
SVVCN	SVJCR/L	SVACR/L-SC	SVJCR/L-SC	S***-SVQCR/L	S***-SVUCR/L	C***-SVQCR/L
Kr: 72°30'	Kr: 93°	Kr: 90°	Kr: 93°	Kr: 107°30'	Kr: 93°	Kr: 107°30'
						
A277	A278	A312	A313	A343	A344	A363
C***-SVUCR/L						
Kr: 93°						
						
A364						



A  
Turning  
B  
Milling  
C  
Drilling  
D  
Technical Information  
E  
Index

# General turning Positive inserts

A

Turning

B

Milling

C

Drilling

D

Technical Information

E

Index

- Ideal machining conditions
- Normal machining conditions
- Unfavourable machining conditions

VCMT	L	I.C	S	d
11 03	11	6.35	3.18	2.8
16 04	16	9.525	4.76	4.4

## Turning inserts

VC** positive insert					HC <sup>1</sup> (CVD)										HC <sup>1</sup> (PVD)			HT	HC <sup>2</sup>	HW												
	P	M	K	N	S	H	YBC103	YB6315	YBC152	YBC203	YBC252	YBC352	YBM153	YBM253	YBD102	YB7315	YBD152	YBD152C	YBG101	YBG102	YBG105	YBG205	YB9320	YPD201	YBS103	YNG151	YNT251	YNG151C	YD101	YD201		
	ISO	r	a <sub>p</sub>	f	YBC103	YB6315	YBC152	YBC203	YBC252	YBC352	YBM153	YBM253	YBD102	YB7315	YBD152	YBD152C	YBG101	YBG102	YBG105	YBG205	YB9320	YPD201	YBS103	YNG151	YNT251	YNG151C	YD101	YD201				
	XF	<b>VCMT110302-XF</b>	0.2	0.5-2.0	0.08-0.20																											
		<b>VCMT110304-XF</b>	0.4	0.5-2.0	0.08-0.20	●																										
		<b>VCMT110308-XF</b>	0.8	0.5-2.0	0.08-0.25	●																										
		<b>VCMT160404-XF</b>	0.4	0.5-2.5	0.08-0.20	●																										
Finishing	<b>VCMT160408-XF</b>	0.8	0.5-2.5	0.08-0.25	●																											
EF	<b>VCMT160404-EF</b>	0.4	0.5-2.5	0.05-0.20																	●											
Medium Cut																																
EM	<b>VCMT160404-EM</b>	0.4	0.5-2.5	0.05-0.35									○								●											
	<b>VCMT160408-EM</b>	0.8	0.5-2.5	0.10-0.45									○								●											
Medium Cut																																
XM	<b>VCMT160412-XM</b>	1.2	1-2.5	0.15-0.35	○	○																										
Medium Cut																																

● Ex stock ○ On demand  
 YBC152F, YBC252F, YBM153F, YBM253F available

HC<sup>1</sup> Coated carbide  
 HT Uncoated cermet  
 HC<sup>2</sup> Coated cermet  
 HW Uncoated carbide

System code > A48

Grade selection > A42

Technical info > A501

Cutting data > A366

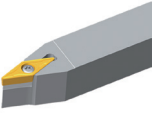
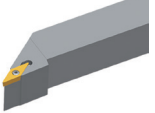
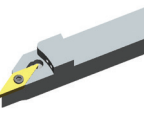
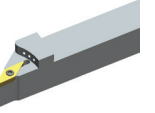
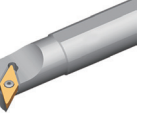
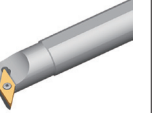
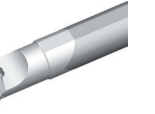

Tool holder						
SVVCN	SVJCR/L	SVACR/L-SC	SVJCR/L-SC	S***-SVQCR/L	S***-SVUCR/L	C***-SVQCR/L
Kr: 72°30'	Kr: 93°	Kr: 90°	Kr: 93°	Kr: 107°30'	Kr: 93°	Kr: 107°30'
						
A277	A278	A312	A313	A343	A344	A363

C***-SVUCR/L
Kr: 93°

A364

<b>A</b>	Turning
<b>B</b>	Milling
<b>C</b>	Drilling
<b>D</b>	Technical Information
<b>E</b>	Index

**C N G A 12 04 08 T 020 20 – 2 (W)**

**1 2 3 4 5 6 7 8 9 10 11 12**

**A**

Turning

**B**

Milling

**C**















Drilling









**D**

Technical Information

**E**

Index

Insert shape		
A 	B 	C 
D 	E 	H 
K 	L 	M 
P 	S 	T 
V 	W 	Z Special







Clearance angle	
A 	B 
C 	D 
E 	F 
G 	N 
P 	O Special

Tolerance class			
Code	I.C [mm]	m [mm]	S [mm]
A	±0,025	±0,005	±0,025
C	±0,025	±0,013	±0,025
E	±0,025	±0,025	±0,025
F	±0,013	±0,005	±0,025
G	±0,025	±0,025	±0,130
H	±0,013	±0,013	±0,025
J	±0,05-0,15	±0,005	±0,025
K	±0,05-0,15	±0,013	±0,025
L	±0,05-0,15	±0,025	±0,025
M	±0,05-0,15	±0,08-0,20	±0,130
N	±0,05-0,15	±0,08-0,20	±0,025
U	±0,08-0,25	±0,13-0,38	±0,130

**1**

**2**

**3**

Fastening features (metric)	
Insert shape	
A 	B 
C 	N 
Q 	W 
X	Special

Cutting edge length l [mm]						
I.C [mm]	Insert shape					
	C	D	S	T	V	W
3,97				06		
5,0				09		
5,56				09		
6,0				09		
6,35	06	07		11	11	
8,0				09		
9,525	09	11	09	16	16	06
10,0				09		
12,0				09		
12,7	12	15	12	22	22	08
15,875	16		15	27		
16,0		19				
19,05	19		19	33		
20,0				09		
25,0	25	25				
25,4			25			
31,75				09		
32				09		

**4**

**5**

Insert thickness S [mm]			
Code	S	Code	S
02	2,38	06	6,35
T2	2,58	T6	6,75
03	3,18	07	7,94
T3	3,97	09	9,52
04	4,76	T9	9,72
T4	4,96	11	11,11
05	5,56	12	12,70
T5	5,95		

6

Nose radius r [mm]	
Code	r
00	-
02	0,2
04	0,4
08	0,8
12	1,2
16	1,6
20	2,0
24	2,4
32	3,2
X	Special
MO	Round inserts

7

Cutting edge profile		
Code	Cutting edge	Insert shape
E	Rounding	
F	Sharp edge	
T	Chamfer	
S	Chamfer + Rounding	

8

Chamfer width b [mm]	
Code	b
010	0,10
015	0,15
020	0,20
025	0,25
030	0,30
035	0,35
040	0,40
045	0,45
050	0,50
100	1,00
200	2,00

9

Chamfer angle $\alpha$	
Code	$\alpha$
05	5°
10	10°
15	15°
20	20°
25	25°
30	30°

10

Cutting edges	
Code	Form
1	
2	
3	
4	

11

Extra	
Code	Description
W	Wiper
HS	Full face single brazed CBN insert
M	Solid CBN with clamping dimple
CB	Chip breaker (CBN)
MED	Chip breaker, fine – medium (PCD)
ROF	Chip breaker, medium – roughing (PCD)
L (L/R)	Full-edge tipped (PCD)

12

A

Turning

B

Milling

C

Drilling

D

Technical Information

E

Index



**A**

Turning

**B**

Milling

**C**



Drilling

**D**

Technical Information











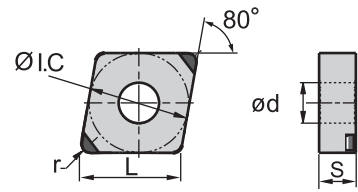































**E**

Index

-  Ideal machining conditions
-  Normal machining conditions
-  Unfavourable machining conditions

CNGA	L	I.C	S	d
12 04	12.9	12.7	4.76	5.16

## Turning CBN inserts

CN** negative insert				BL (CBN)			BC (CBN)		BH (CBN)		
	<b>P</b>										
	<b>M</b>										
	<b>K</b>										
	<b>N</b>										
	<b>S</b>										
	<b>H</b>										
ISO	r	a <sub>p</sub>	f	YCB112	YCB113	YCB121	YCB131	YCB113C	YCB121C	YCB131C	YCB215
CNGA120402S01020-2	0.2	0.08-0.50	0.05-0.15								
CNGA120402S01225-2	0.2	0.08-0.50	0.05-0.15								
CNGA120404E-2	0.4	0.08-0.50	0.05-0.20								
CNGA120404S01020-2	0.4	0.08-0.50	0.05-0.20								
CNGA120404S01225-2	0.4	0.08-0.50	0.05-0.20								
CNGA120408E-2	0.8	0.08-0.50	0.05-0.25								
CNGA120408S01525-2	0.8	0.08-0.50	0.05-0.25								
CNGA120408S02020-2	0.8	0.08-0.50	0.05-0.25								
CNGA120412E-2	1.2	0.08-0.50	0.05-0.30								
CNGA120412S01020-2	1.2	0.08-0.50	0.05-0.30								
CNGA120412S01525-2	1.2	0.08-0.50	0.05-0.30								
CNGA120412S02020-2	1.2	0.08-0.50	0.05-0.30								
CNGA120416S01020-2	1.6	0.08-0.50	0.05-0.35								
CNGA120416S01525-2	1.6	0.08-0.50	0.05-0.35								
CNGA120416S02020-2	1.6	0.08-0.50	0.05-0.35								
CNGA120408S01525-2W	0.8	0.08-0.50	0.05-0.25								
CNGA120408S02020-2W	0.8	0.08-0.50	0.05-0.25								

- Ex stock    ○ On demand
- BL CBN with a low CBN content
- BC CBN with coating
- BH CBN with a high CBN content

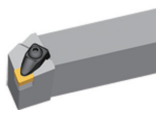
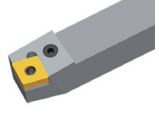
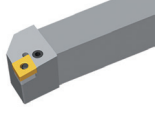
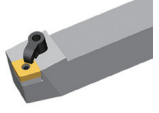
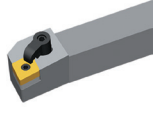
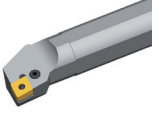
Tool holder					
DCLNR/L	PCBNR/L	PCLNR/L	MCBNR/L	MCLNR/L	S***-PCLNR/L
Kr: 95°	Kr: 75°	Kr: 95°	Kr: 75°	Kr: 95°	Kr: 95°
					
A230	A237	A238	A252	A253	A324



- Ideal machining conditions
- ⊗ Normal machining conditions
- ⊗ Unfavourable machining conditions

DNGA	L	I.C	S	d
15 06	15.5	12.7	6.35	5.16

## Turning CBN inserts

DN** negative insert				BL (CBN)				BC (CBN)			BH (CBN)		
	<b>P</b>												
	<b>M</b>												
	<b>K</b>												
	<b>N</b>												
	<b>S</b>	●			⊗								
	<b>H</b>	○	⊗	⊗					○	⊗	⊗		
ISO	r	a <sub>p</sub>	f	YCB112	YCB113	YCB121	YCB131	YCB113C	YCB121C	YCB131C		YCB215	
<b>DNGA150604E-2</b>	0.4	0.08-0.50	0.05-0.20	○		○							
<b>DNGA150604S01020-2</b>	0.4	0.08-0.50	0.05-0.20			○			○			○	
<b>DNGA150604S01225-2</b>	0.4	0.08-0.50	0.05-0.20	○		○			○				
<b>DNGA150608E-2</b>	0.8	0.08-0.50	0.05-0.25	○		○							
<b>DNGA150608S01020-2</b>	0.8	0.08-0.50	0.05-0.25									○	
<b>DNGA150608S01525-2</b>	0.8	0.08-0.50	0.05-0.25		●	●		●					
<b>DNGA150608S02020-2</b>	0.8	0.08-0.50	0.05-0.25			●			●				
<b>DNGA150612S01020-2</b>	1.2	0.08-0.50	0.05-0.30									○	
<b>DNGA150612S01525-2</b>	1.2	0.08-0.50	0.05-0.30		●	○			○				
<b>DNGA150612S02020-2</b>	1.2	0.08-0.50	0.05-0.30			●				○			



● Ex stock ○ On demand

BL CBN with a low CBN content  
 BC CBN with coating  
 BH CBN with a high CBN content

Tool holder						
<b>DDJNR/L</b> Kr: 93°	<b>PDJNR/L</b> Kr: 93°	<b>PDNNR/L</b> Kr: 63°	<b>MDJNR/L</b> Kr: 93°	<b>MDPNN</b> Kr: 62°30'	<b>S***-PDSNR/L</b> Kr: 62°30'	<b>S***-PDUNR/L</b> Kr: 93°
A231	A240	A241	A254	A255	A326	A327







**A**

Turning

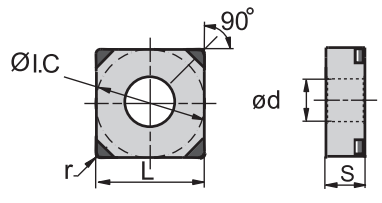
-  Ideal machining conditions
-  Normal machining conditions
-  Unfavourable machining conditions









SNGA	L	I.C	S	d
12 04	12.7	12.7	4.76	5.16

## Turning CBN inserts

SN** negative insert				BL (CBN)			BC (CBN)			BH (CBN)			
	<b>P</b>												
	<b>M</b>												
	<b>K</b>												
	<b>N</b>												
	<b>S</b>												
	<b>H</b>												

**B**

Milling

ISO	r	a <sub>p</sub>	f	YCB112			YCB113			YCB121			YCB131			YCB113C			YCB121C			YCB131C			YCB215
	<b>SNGA120408S01020-4</b>	0.8	0.08-0.50	0.05-0.25																					
	<b>SNGA120408S01525-4</b>	0.8	0.08-0.50	0.05-0.25																					
	<b>SNGA120408S02020-4</b>	0.8	0.08-0.50	0.05-0.25																					
	<b>SNGA120412S01020-4</b>	1.2	0.08-0.50	0.05-0.30																					
	<b>SNGA120412S01525-4</b>	1.2	0.08-0.50	0.05-0.30																					
	<b>SNGA120412S02020-4</b>	1.2	0.08-0.50	0.05-0.30																					

● Ex stock   ○ On demand

BL CBN with a low CBN content  
 BC CBN with coating  
 BH CBN with a high CBN content

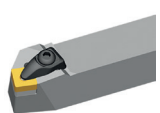
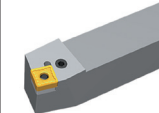
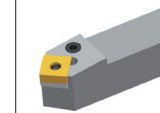
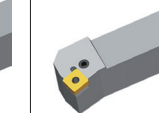
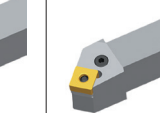
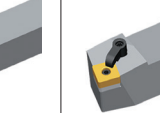
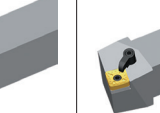

**C**

Drilling

Tool holder						
DSBNR/L	PSBNR/L	PSDNN	PSKNR/L	PSSNR/L	MSBNR/L	MSRNR/L
Kr: 75°	Kr: 75°	Kr: 45°	Kr: 75°	Kr: 45°	Kr: 75°	Kr: 75°
						
A232	A242	A244	A245	A246	A256	A257

**D**

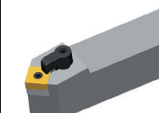
Technical Information

MSKNR/L	MSDNN	S***-PSKNR/L
Kr: 75°	Kr: 45°	Kr: 75°
		
A258	A259	A329

**E**

Index



- Ideal machining conditions
- ⊗ Normal machining conditions
- ⊗ Unfavourable machining conditions

TNGA	L	I.C	S	d
16 04	16.5	9.525	4.76	3.81

## Turning CBN inserts

TN** negative insert				BL (CBN)				BC (CBN)			BH (CBN)						
				<b>P</b>													
				<b>M</b>													
				<b>K</b>								●					
				<b>N</b>													
				<b>S</b>	●	⊗											
				<b>H</b>	○	⊗	⊗										
ISO				r	a <sub>p</sub>	f	YCB112	YCB113	YCB121	YCB131	YCB113C	YCB121C	YCB131C	YCB215			
				<b>TNGA160404S01020-3</b>	0.4	0.08-0.50	0.05-0.20		○				○		○		
				<b>TNGA160404S01225-3</b>	0.4	0.08-0.50	0.05-0.20		○					○			
				<b>TNGA160408S01020-3</b>	0.8	0.08-0.50	0.05-0.25								○		
				<b>TNGA160408S01525-3</b>	0.8	0.08-0.50	0.05-0.25		○	○					○		
				<b>TNGA160408S02020-3</b>	0.8	0.08-0.50	0.05-0.25				●				○		
				<b>TNGA160412S01020-3</b>	1.2	0.08-0.50	0.05-0.30									○	
				<b>TNGA160412S01525-3</b>	1.2	0.08-0.50	0.05-0.30				○	○				○	
				<b>TNGA160412S02020-3</b>	1.2	0.08-0.50	0.05-0.30				○					○	

● Ex stock    ○ On demand

BL CBN with a low CBN content  
 BC CBN with coating  
 BH CBN with a high CBN content

Tool holder						
<b>DTGNR/L</b> Kr: 91°	<b>PTFNR/L</b> Kr: 91°	<b>PTTNR/L</b> Kr: 60°	<b>PTGNR/L</b> Kr: 90°	<b>MTGNR/L</b> Kr: 90°	<b>MTJNR/L</b> Kr: 93°	<b>MTJNR/L-Z</b> Kr: 93°
A233	A247	A248	A249	A260	A261	A262
<b>MTFNR/L</b> Kr: 91°	<b>S***-PTFNR/L</b> Kr: 90°					
A263	A330					

System code > A158

Grade selection > A42

Technical info > A501

Cutting data > A366



**A**

Turning

- Ideal machining conditions
- ⊗ Normal machining conditions
- ⊗ Unfavourable machining conditions

VNGA	L	I.C	S	d
16 04	16.6	9.525	4.76	3.81

## Turning CBN inserts

VN** negative insert				BL (CBN)			BC (CBN)			BH (CBN)				
				<b>P</b>										
				<b>M</b>										
				<b>K</b>										●
				<b>N</b>										
				<b>S</b>	●	⊗								
				<b>H</b>	○	⊗	⊗							

**B**

Milling

ISO	r	a <sub>p</sub>	f	BL (CBN)			BC (CBN)			BH (CBN)		
				YCB112	YCB113	YCB121	YCB131	YCB113C	YCB121C	YCB131C	YCB215	
	<b>VNGA160404S01020-2</b>	0.4	0.08-0.50	0.05-0.20		●						○
	<b>VNGA160404S01225-2</b>	0.4	0.08-0.50	0.05-0.20		●						○
	<b>VNGA160408S01020-2</b>	0.8	0.08-0.50	0.05-0.25								○
	<b>VNGA160408S01525-2</b>	0.8	0.08-0.50	0.05-0.25								○
	<b>VNGA160408S02020-2</b>	0.8	0.08-0.50	0.05-0.25			●					○

● Ex stock    ○ On demand

BL CBN with a low CBN content  
 BC CBN with coating  
 BH CBN with a high CBN content

**C**

Drilling

Tool holder			
DVVNN	DVJNR/L	MVVNN	MVJNR/L
Kr: 72°30'	Kr: 93°	Kr: 72°30'	Kr: 93°
A234	A235	A264	A265

**D**

Technical Information

**E**



Index

System code > A158

Grade selection > A42







Technical info > A501

Cutting data > A366

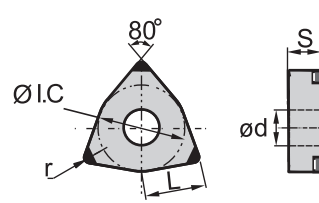
-  Ideal machining conditions
-  Normal machining conditions
-  Unfavourable machining conditions

WNGA	L	I.C	S	d
08 04	8.69	12.7	4.76	5.16

## Turning CBN inserts

WN** negative insert					BL (CBN)				BC (CBN)			BH (CBN)						
					<b>P</b>													
					<b>M</b>													
					<b>K</b>													
					<b>N</b>													
					<b>S</b>													
					<b>H</b>													
ISO	r	a <sub>p</sub>	f	YCB112	YCB113	YCB121	YCB131	YCB113C	YCB121C	YCB131C		YCB215						
	<b>WNGA080404S01020-3</b>	0.4	0.08-0.50	0.05-0.20														
	<b>WNGA080404S01225-3</b>	0.4	0.08-0.50	0.05-0.20														
	<b>WNGA080408S01020-3</b>	0.8	0.08-0.50	0.05-0.25														
	<b>WNGA080408S01525-3</b>	0.8	0.08-0.50	0.05-0.25														
	<b>WNGA080408S02020-3</b>	0.8	0.08-0.50	0.05-0.25														
	<b>WNGA080412S01020-3</b>	1.2	0.08-0.50	0.05-0.30														
	<b>WNGA080412S01525-3</b>	1.2	0.08-0.50	0.05-0.30														
	<b>WNGA080412S02020-3</b>	1.2	0.08-0.50	0.05-0.30														

● Ex stock    ○ On demand

BL CBN with a low CBN content  
 BC CBN with coating  
 BH CBN with a high CBN content

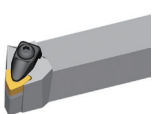
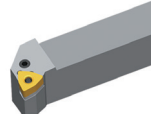
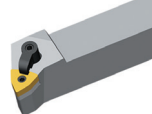
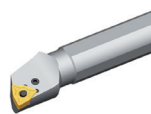
Tool holder			
<b>DWLNLR/L</b>	<b>PWLNLR/L</b>	<b>MWLNLR/L</b>	<b>S***-PWLNLR/L</b>
Kr: 95°	Kr: 95°	Kr: 95°	Kr: 95°
			
A236	A251	A266	A332

System code > A158

Grade selection > A42

Technical info > A501

Cutting data > A366



**A**

Turning

- Ideal machining conditions
- ⊗ Normal machining conditions
- ⊗ Unfavourable machining conditions

ZNEX	I.C	S	d
04 01	4.76	1.59	2.3

## Turning CBN inserts

ZN** negative insert				BL (CBN)			BC (CBN)			BH (CBN)				
				<b>P</b>										
				<b>M</b>										
				<b>K</b>										●
				<b>N</b>										
				<b>S</b>	●	⊗								
				<b>H</b>	○	⊗	⊗		○	⊗	⊗			

**B**

Milling

ISO	r	a <sub>p</sub>	f	BL (CBN)			BC (CBN)			BH (CBN)		
				YCB112	YCB113	YCB121	YCB131	YCB113C	YCB121C	YCB131C	YCB215	
	ZNEX040102S01515	0.2	0.08-0.50	0.05-0.15	○	○						
	ZNEX040104S01515	0.4	0.08-0.50	0.05-0.20	○	○						

● Ex stock    ○ On demand

BL CBN with a low CBN content  
 BC CBN with coating  
 BH CBN with a high CBN content

**C**

Drilling

Tool holder  
**C\*\*\*-SZLNR/L**  
 Kr: 95°

A365

**D**

Technical Information

**E**

Index

System code > A158

Grade selection > A42

Technical info > A501

Cutting data > A366

## Turning CBN inserts

- Ideal machining conditions
- ⊗ Normal machining conditions
- ⊗ Unfavourable machining conditions

CCGW	L	I.C	S	d
06 02	6.4	6.35	2.38	2.8
09 T3	9.7	9.525	3.97	4.4
12 04	12.9	12.7	4.76	5.5

CC** positive insert				BL (CBN)				BC (CBN)			BH (CBN)				
				<b>P</b>											
				<b>M</b>											
				<b>K</b>											
				<b>N</b>											
				<b>S</b>	●	⊗									
				<b>H</b>	○	⊗	⊗								
ISO	r	a <sub>p</sub>	f	YCB112	YCB113	YCB121	YCB131	YCB113C	YCB121C	YCB131C	YCB215				
CCGW060202S01020-2	0.2	0.08-0.50	0.05-0.20		○				○		○				
CCGW060202S01225-2	0.2	0.08-0.50	0.05-0.150.05-0.20		○				○		○				
CCGW060204S01020-2	0.4	0.08-0.50	0.05-0.20		○				○		○				
CCGW060204S01225-2	0.4	0.08-0.50	0.05-0.20		○				○		○				
CCGW060208S01020-2	0.8	0.08-0.50	0.05-0.25								○				
CCGW060208S01525-2	0.8	0.08-0.50	0.05-0.25		○				○						
CCGW060208S02020-2	0.8	0.08-0.50	0.05-0.25			○			○						
CCGW09T302S01020-2	0.2	0.08-0.50	0.05-0.15			○			○		○				
CCGW09T302S01225-2	0.2	0.08-0.50	0.05-0.15			○			○		○				
CCGW09T304E-2	0.4	0.08-0.50	0.05-0.20		○		○								
CCGW09T304S01020-2	0.4	0.08-0.50	0.05-0.20			●			○		○				
CCGW09T304S01225-2	0.4	0.08-0.50	0.05-0.20		●				○						
CCGW09T308E-2	0.8	0.08-0.50	0.05-0.25		○		○								
CCGW09T308S01020-2	0.8	0.08-0.50	0.05-0.25								●				
CCGW09T308S01525-2	0.8	0.08-0.50	0.05-0.25		●	○			○						
CCGW09T308S02020-2	0.8	0.08-0.50	0.05-0.25			●			●						
CCGW09T312E-2	1.2	0.08-0.50	0.05-0.30		○		○								
CCGW120404S01020-2	0.4	0.08-0.50	0.05-0.20			○			○		○				
CCGW120404S01225-2	0.4	0.08-0.50	0.05-0.20			○			○						
CCGW120408S01020-2	0.8	0.08-0.50	0.05-0.25								○				
CCGW120408S01525-2	0.8	0.08-0.50	0.05-0.25			○	○		○						
CCGW120408S02020-2	0.8	0.08-0.50	0.05-0.25				○		○						
CCGW120412S01020-2	1.2	0.08-0.50	0.05-0.30								○				
CCGW120412S01525-2	1.2	0.08-0.50	0.05-0.30			○	○		○						
CCGW120412S02020-2	1.2	0.08-0.50	0.05-0.30				○		○						





● Ex stock   ○ On demand

BL CBN with a low CBN content  
 BC CBN with coating  
 BH CBN with a high CBN content

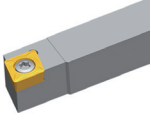
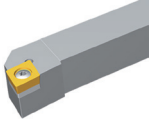
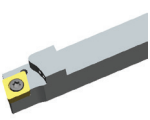
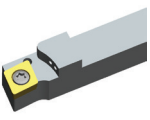

**A**

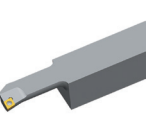
Turning

Tool holder						
SCACR/L	SCLCR/L	SCACR/L-SC	SCLCR/L-SC	A***-SCLCR/L	S***-SCFCR/L	S***-SCLCR
Kr: 90°	Kr: 95°	Kr: 90°	Kr: 95°	Kr: 95°	Kr: 90°	Kr: 95°
						
A269	A270	A306	A307	A334	A352	A353

**B**

Milling

E***-SCLCR/L
Kr: 95°

A355

**C**

Drilling

**D**

Technical Information

**E**

Index

System code > A158

Grade selection > A42

Technical info > A501

Cutting data > A366

- Ideal machining conditions
- ⊗ Normal machining conditions
- ⊗ Unfavourable machining conditions

DCGW	L	I.C	S	d
07 02	7.8	6.35	2.38	2.8
11 T3	11.6	9.525	3.97	4.4

## Turning CBN inserts

DC** positive insert					BL (CBN)				BC (CBN)			BH (CBN)						
					<b>P</b>													
					<b>M</b>													
					<b>K</b>													
					<b>N</b>													
					<b>S</b>	●		⊗										
					<b>H</b>	○	⊗	⊗		○	⊗	⊗						
ISO	r	a <sub>p</sub>	f	YCB112	YCB113	YCB121	YCB131	YCB113C	YCB121C	YCB131C	YCB215							
DCGW070202S01020-2	0.2	0.08-0.50	0.05-0.15	●				○										
DCGW070202S01225-2	0.2	0.08-0.50	0.05-0.15	○				○										
DCGW070204S01020-2	0.4	0.08-0.50	0.05-0.20	●				○			○							
DCGW070204S01225-2	0.4	0.08-0.50	0.05-0.20	●				○										
DCGW070208S01020-2	0.8	0.08-0.50	0.05-0.25								○							
DCGW070208S01525-2	0.8	0.08-0.50	0.05-0.25	●				○										
DCGW070208S02020-2	0.8	0.08-0.50	0.05-0.25	●				○										
DCGW11T302S01020-2	0.2	0.08-0.50	0.05-0.15	○				○			○							
DCGW11T302S01225-2	0.2	0.08-0.50	0.05-0.15	○				○										
DCGW11T304E-2	0.4	0.08-0.50	0.05-0.20	○		○												
DCGW11T304S01020-2	0.4	0.08-0.50	0.05-0.20	●				○			●							
DCGW11T304S01225-2	0.4	0.08-0.50	0.05-0.20	●				○										
DCGW11T308E-2	0.8	0.08-0.50	0.05-0.25	○		○												
DCGW11T308S01020-2	0.8	0.08-0.50	0.05-0.25								●							
DCGW11T308S01525-2	0.8	0.08-0.50	0.05-0.25	●	○			●										
DCGW11T308S02020-2	0.8	0.08-0.50	0.05-0.25	●				●										
DCGW11T312E-2	1.2	0.08-0.50	0.05-0.30	○		○												

● Ex stock ○ On demand

BL CBN with a low CBN content  
 BC CBN with coating  
 BH CBN with a high CBN content

Tool holder						
SDACR/L	SDJCR/L	SDNCN	SDACR/L-SC	SDHCR/L-SC	SDJCR/L-SC	SDNCN-SC
Kr: 90°	Kr: 93°	Kr: 62°30'	Kr: 90°	Kr: 107°30'	Kr: 93°	Kr: 62°30'
A271	A272	A273	A308	A309	A310	A311

S***-SDQCR/L	A***-SDUCR/L	S***-SDZCR/L	E***-SDQCR/L
Kr: 107°30'	Kr: 93°	Kr: 85°	Kr: 107°30'
A336	A337	A338	A357

System code > A158

Grade selection > A42

Technical info > A501

Cutting data > A366



**A**

Turning

- Ideal machining conditions
- ⊗ Normal machining conditions
- ⊗ Unfavourable machining conditions

TCGW	L	I.C	S	d
11 02	11	6.35	2.38	2.5
16 T3	16.5	9.525	3.97	4.4

## Turning CBN inserts

TC** positive insert				BL (CBN)			BC (CBN)			BH (CBN)		
	<b>P</b>											
	<b>M</b>											
	<b>K</b>										●	
	<b>N</b>											
	<b>S</b>	●	⊗									
	<b>H</b>	○	⊗	⊗			○	⊗	⊗			

**B**

Milling

ISO	r	a <sub>p</sub>	f	YCB112	YCB113	YCB121	YCB131	YCB113C	YCB121C	YCB131C	YCB215
					<b>TCGW110204S01020-3</b>	0.4	0.08-0.50	0.05-0.20		○	
	<b>TCGW110204S01225-3</b>	0.4	0.08-0.50	0.05-0.20	○			○			○
	<b>TCGW110208S01020-3</b>	0.8	0.08-0.50	0.05-0.25							○
	<b>TCGW110208S01525-3</b>	0.8	0.08-0.50	0.05-0.25	○			○			○
	<b>TCGW110208S02020-3</b>	0.8	0.08-0.50	0.05-0.25	○			○			○
	<b>TCGW16T304S01020-3</b>	0.4	0.08-0.50	0.05-0.20		●		○			○
	<b>TCGW16T304S01225-3</b>	0.4	0.08-0.50	0.05-0.20	●			○			○
	<b>TCGW16T308S01020-3</b>	0.8	0.08-0.50	0.05-0.25							○
	<b>TCGW16T308S01525-3</b>	0.8	0.08-0.50	0.05-0.25	●			○			○
	<b>TCGW16T308S02020-3</b>	0.8	0.08-0.50	0.05-0.25		●		○			○

● Ex stock    ○ On demand

BL CBN with a low CBN content  
 BC CBN with coating  
 BH CBN with a high CBN content

**C**

Drilling

Tool holder					
STACR/L	STFCR/L	STGCR/L	STTCR/L	S***-STFCR/L	E***-STFCR/L
Kr: 90°	Kr: 91°	Kr: 91°	Kr: 60°	Kr: 91°	Kr: 90°
A283	A284	A285	A286	A341	A361



**D**

Technical Information

**E**











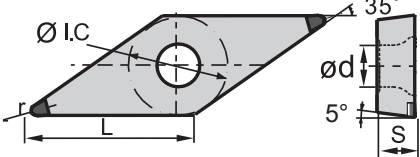







Index



-  Ideal machining conditions
-  Normal machining conditions
-  Unfavourable machining conditions



VBGW	L	I.C	S	d
16 04	16.6	9.525	4.76	4.4

## Turning CBN inserts

VB** positive insert				BL (CBN)				BC (CBN)			BH (CBN)						
				<b>P</b>													
				<b>M</b>													
				<b>K</b>													
				<b>N</b>													
				<b>S</b>													
				<b>H</b>													
ISO	r	a <sub>p</sub>	f	YCB112	YCB113	YCB121	YCB131	YCB113C	YCB121C	YCB131C	YCB215						
	<b>VBGW160404S01020-2</b>	0.4	0.08-0.50	0.05-0.20													
	<b>VBGW160404S01225-2</b>	0.4	0.08-0.50	0.05-0.20													
	<b>VBGW160408S01020-2</b>	0.8	0.08-0.50	0.05-0.25													
	<b>VBGW160408S01525-2</b>	0.8	0.08-0.50	0.05-0.25													
	<b>VBGW160408S02020-2</b>	0.8	0.08-0.50	0.05-0.25													

● Ex stock    ○ On demand

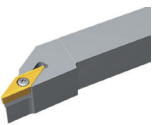
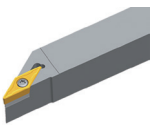
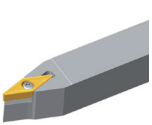
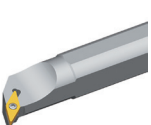
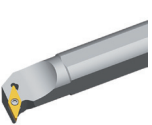
BL CBN with a low CBN content  
 BC CBN with coating  
 BH CBN with a high CBN content

Tool holder					
SVJBR/L	SVABR/L	SVVBN	S***-SVQBR/L	S***-SVUBR/L	S***-SVXBR/L
Kr: 93°	Kr: 90°	Kr: 72°30'	Kr: 107°30'	Kr: 93°	Kr: 93°
					
A274	A275	A276	A345	A346	A347

System code > A158

Grade selection > A42



Technical info > A501

Cutting data > A366











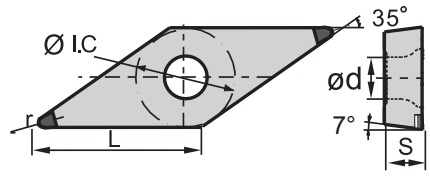

**A**

Turning

-  Ideal machining conditions
-  Normal machining conditions
-  Unfavourable machining conditions





















VCGW	L	I.C	S	d
11 03	11.1	6.35	3.18	2.8
16 04	16.6	9.525	4.76	4.4

## Turning CBN inserts

VC** positive insert		BL (CBN)			BC (CBN)			BH (CBN)		
	<b>P</b>									
	<b>M</b>									
	<b>K</b>									
	<b>N</b>									
	<b>S</b>									
	<b>H</b>									

**B**

Milling





ISO	r	a <sub>p</sub>	f	BL (CBN)			BC (CBN)			BH (CBN)
				YCB112	YCB113	YCB121	YCB131	YCB113C	YCB121C	
<b>VCGW110302E-2</b>	0.2	0.08-0.50	0.05-0.15							
<b>VCGW110304E-2</b>	0.4	0.08-0.50	0.05-0.20							
<b>VCGW160404E-2</b>	0.4	0.08-0.50	0.05-0.20							
<b>VCGW160404S01020-2</b>	0.4	0.08-0.50	0.05-0.20							
<b>VCGW160404S01225-2</b>	0.4	0.08-0.50	0.05-0.20							
<b>VCGW160408E-2</b>	0.8	0.08-0.50	0.05-0.25							
<b>VCGW160408S01020-2</b>	0.8	0.08-0.50	0.05-0.25							
<b>VCGW160408S01525-2</b>	0.8	0.08-0.50	0.05-0.25							
<b>VCGW160408S02020-2</b>	0.8	0.08-0.50	0.05-0.25							
<b>VCGW160412E-2</b>	1.2	0.08-0.50	0.05-0.30							

● Ex stock ○ On demand

BL CBN with a low CBN content  
 BC CBN with coating  
 BH CBN with a high CBN content

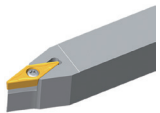
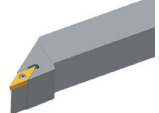
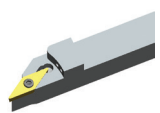
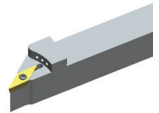
**C**

Drilling

Tool holder						
<b>SVVCN</b> Kr: 72°30'	<b>SVJCR/L</b> Kr: 93°	<b>SVACR/L-SC</b> Kr: 90°	<b>SVJCR/L-SC</b> Kr: 93°	<b>S***-SVQCR/L</b> Kr: 107°30'	<b>S***-SVUCR/L</b> Kr: 93°	<b>C***-SVQCR/L</b> Kr: 107°30'
						
A277	A278	A312	A313	A343	A344	A363

**D**

Technical Information

<b>C***-SVUCR/L</b> Kr: 93°

A364

**E**

Index



- Ideal machining conditions
- ⊗ Normal machining conditions
- ⊗ Unfavourable machining conditions

CNGN	L	I.C	S
09 03	9.7	9.525	3.18
12 04	12.9	12.7	4.76

## Turning CBN inserts

CN** negative insert				BL (CBN)	BC (CBN)	BH (CBN)	
				P			
				M			
				K		⊗	
				N			
				S			
				H	⊗	⊗	
ISO	r	a <sub>p</sub>	f	YZB630	YZB630C	YZB223	
	CNGN090308S01525	0.8	0.5-2.0	0.3-0.5	○	○	○
	CNGN090308T01525	0.8	0.5-2.0	0.3-0.5	○	○	○
	CNGN090312S01525	1.2	0.5-2.0	0.3-0.5	○	○	○
	CNGN090312T01525	1.2	0.5-2.0	0.3-0.5	○	○	○
	CNGN120408S01525	0.8	0.5-2.0	0.3-0.5	○	○	○
	CNGN120408T01525	0.8	0.5-2.0	0.3-0.5	○	○	●
	CNGN120412S01525	1.2	0.5-2.0	0.3-0.5	●	○	○
	CNGN120412T01525	1.2	0.5-2.0	0.3-0.5	○	○	●
	CNGN120416S01525	1.6	0.5-2.0	0.3-0.5	○	○	○
	CNGN120408T01525-M	0.8	0.5-2.0	0.3-0.5	○	○	○
	CNGN120412T01525-M	1.2	0.5-2.0	0.3-0.5	○	○	○
	CNGN120416T01525-M	1.6	0.5-2.0	0.3-0.5	○	○	○

● Ex stock   ○ On demand

BL CBN with a low CBN content  
 BC CBN with coating  
 BH CBN with a high CBN content

Tool holder

CCLNR/L

Kr: 95°

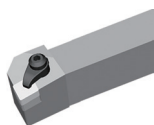

A292

System code > A158

Grade selection > A42

Technical info > A501

Cutting data > A366



**A**

Turning

- Ideal machining conditions
- ⊗ Normal machining conditions
- ⊗ Unfavourable machining conditions

RNGN	I.C	S
<b>09 03</b>	9.525	3.18
<b>12 04</b>	12.7	4.76

## Turning CBN inserts

RN** negative insert		BL (CBN)	BC (CBN)	BH (CBN)
	<b>P</b>			
	<b>M</b>			
	<b>K</b>			⊗
	<b>N</b>			
	<b>S</b>			
	<b>H</b>	⊗	⊗	

**B**

Milling

ISO	a <sub>p</sub>	f	YZB630	YZB630C	YZB223
	<b>RNGN090300S01525</b>	0.5-2.0	0.3-0.5	○	○
	<b>RNGN090300T01525</b>	0.5-2.0	0.3-0.5	○	○
	<b>RNGN120400S01525</b>	0.5-2.0	0.3-0.5	○	○
	<b>RNGN120400T01525</b>	0.5-2.0	0.3-0.5	○	●

● Ex stock    ○ On demand

BL CBN with a low CBN content  
 BC CBN with coating  
 BH CBN with a high CBN content

**C**

Drilling

Tool holder  
**CRDNN**

---



---

A298



**D**

Technical Information

**E**







Index

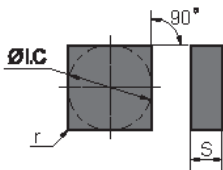

-  Ideal machining conditions
-  Normal machining conditions
-  Unfavourable machining conditions

SNGN	L	I.C	S
12 04	12.7	12.7	4.76

## Turning CBN inserts

SN** negative insert				BL (CBN)	BC (CBN)	BH (CBN)	
				P			
				M			
				K			
				N			
				S			
				H			
ISO	r	a <sub>p</sub>	f	YZB630	YZB630C	YZB223	
	SNGN120408S01525	0.8	0.5-2.0	0.3-0.5	○	○	
	SNGN120408T01525	0.8	0.5-2.0	0.3-0.5			●
	SNGN120412S01525	1.2	0.5-2.0	0.3-0.5	○	○	
	SNGN120412T01525	1.2	0.5-2.0	0.3-0.5			○
	SNGN120416T01525	1.6	0.5-2.0	0.3-0.5			●
	SNGN120412T01525-M	1.2	0.5-2.0	0.3-0.5			○
	SNGN120416T01525-M	1.6	0.5-2.0	0.3-0.5			●

● Ex stock    ○ On demand

BL CBN with a low CBN content  
 BC CBN with coating  
 BH CBN with a high CBN content

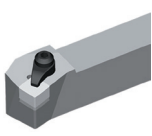
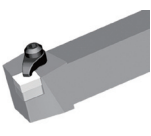
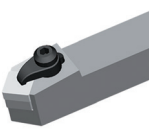
Tool holder		
CSKNR/L Kr: 75°	CSRNR/L Kr: 75°	CSDNN Kr: 45°
		
A296	A297	A299



**A**

Turning

- Ideal machining conditions
- ⊗ Normal machining conditions
- ⊗ Unfavourable machining conditions

WNGN	L	I.C	S
<b>08 04</b>	8.69	12.7	4.76

## Turning CBN inserts

WN** negative insert				BL (CBN)	BC (CBN)	BH (CBN)
	<b>P</b>					
	<b>M</b>					
	<b>K</b>					<span style="color: red;">⊗</span>
	<b>N</b>					
	<b>S</b>					
	<b>H</b>	<span style="color: blue;">⊗</span>			<span style="color: blue;">⊗</span>	

**B**

Milling

ISO		r	a <sub>p</sub>	f	YZB630	YZB630C	YZB223
	<b>WNGN080408T01525</b>	0.8	0.5-2.0	0.3-0.5			○
	<b>WNGN080412T01525</b>	1.2	0.5-2.0	0.3-0.5			○
	<b>WNGN080416T01525</b>	1.6	0.5-2.0	0.3-0.5			○
	<b>WNGN080408T01525-M</b>	0.8	0.5-2.0	0.3-0.5			○
	<b>WNGN080412T01525-M</b>	1.2	0.5-2.0	0.3-0.5			○
	<b>WNGN080416T01525-M</b>	1.6	0.5-2.0	0.3-0.5			○

**C**

Drilling

● Ex stock    ○ On demand

BL CBN with a low CBN content  
 BC CBN with coating  
 BH CBN with a high CBN content



**D**

Technical Information

**E**







Index

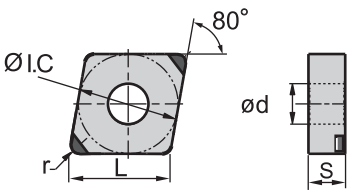

-  Ideal machining conditions
-  Normal machining conditions
-  Unfavourable machining conditions

CNGA	L	I.C	S	d
12 04	12.9	12.7	4.76	5.16

**Turning PCD inserts**

CN** negative insert				DP																							
				P																							
				M																							
				K																							
				N																							
				S																							
				H																							
ISO	r	a <sub>p</sub>	f	YCD421																							
	CNGA120402F-1	0.2	0.08-0.50	0.05-0.15																							
	CNGA120404F-1	0.4	0.08-0.50	0.05-0.20																							
	CNGA120408F-1	0.8	0.08-0.50	0.05-0.25																							
	CNGA120412F-1	1.2	0.08-0.50	0.05-0.30																							

● Ex stock    ○ On demand DP Polycrystalline diamond

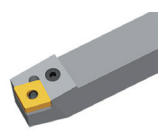
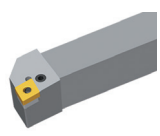
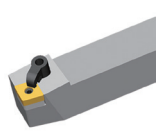
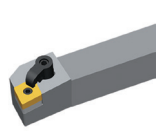
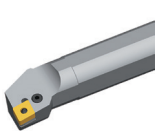
Tool holder					
DCLNR/L	PCBNR/L	PCLNR/L	MCBNR/L	MCLNR/L	S***-PCLNR/L
Kr: 95°	Kr: 75°	Kr: 95°	Kr: 75°	Kr: 95°	Kr: 95°
					
A230	A237	A238	A252	A253	A324

# General turning PCBN & PCD inserts

**A**

Turning

- Ideal machining conditions
- Normal machining conditions
- Unfavourable machining conditions

DNGA	L	I.C	S	d
15 06	15.5	12.7	6.35	5.16

## Turning PCD inserts

DN** negative insert	DP									
	P									
	M									
	K									
	N	●								
	S									
H										

**B**

Milling

ISO	r	a <sub>p</sub>	f	YCD421														
	DNGA150602F-1	0.2	0.08-0.50	0.05-0.15	○													
	DNGA150604F-1	0.4	0.08-0.50	0.05-0.20	○													
	DNGA150608F-1	0.8	0.08-0.50	0.05-0.25	○													

● Ex stock ○ On demand DP Polycrystalline diamond

**C**

Drilling

Tool holder						
DDJNR/L	PDJNR/L	PDNNR/L	MDJNR/L	MDPNN	S***-PDSNR/L	S***-PDUNR/L
Kr: 93°	Kr: 93°	Kr: 63°	Kr: 93°	Kr: 62°30'	Kr: 62°30'	Kr: 93°
A231	A240	A241	A254	A255	A326	A327

**D**

Technical Information

**E**

Index



- Ideal machining conditions
- Normal machining conditions
- Unfavourable machining conditions

VNGA	L	I.C	S	d
16 04	16.6	9.525	4.76	3.81

**Turning PCD inserts**

VN** negative insert				DP																			
				<b>P</b>																			
				<b>M</b>																			
				<b>K</b>																			
				<b>N</b>																			
				<b>S</b>																			
				<b>H</b>																			
ISO	r	a <sub>p</sub>	f	YCD421																			
	VNGA160402F-1	0.2	0.08-0.50	0.05-0.15																			
	VNGA160404F-1	0.4	0.08-0.50	0.05-0.20																			

● Ex stock    ○ On demand

DP Polycrystalline diamond

Tool holder			
DVVNN Kr: 72°30'	DVJNR/L Kr: 93°	MVVNN Kr: 72°30'	MVJNR/L Kr: 93°
A234	A235	A264	A265

- A
- Turning
- B
- Milling
- C
- Drilling
- D
- Technical Information
- E
- Index

**A**

Turning

**B**

Milling

**C**

Drilling

**D**

Technical Information

**E**

Index

CCGT	L	I.C	S	d
<b>06</b> 02	6.4	6.35	2.38	2.8
<b>09</b> T3	9.7	9.525	3.97	4.4
<b>12</b> 04	12.9	12.7	4.76	5.56

- Ideal machining conditions
- Normal machining conditions
- ⊗ Unfavourable machining conditions

## Turning PCD inserts

CC** positive insert		DP									
	<b>P</b>										
	<b>M</b>										
	<b>K</b>										
	<b>N</b>	○									
	<b>S</b>										
	<b>H</b>										

ISO	r	a <sub>p</sub>	f	YCD421	
	<b>CCGT060202F-1</b>	0.2	0.05-0.50	0.05-0.15	○
	<b>CCGT060204F-1</b>	0.4	0.08-0.50	0.05-0.20	●
	<b>CCGT060208F-1</b>	0.8	0.08-0.50	0.05-0.25	○
	<b>CCGT09T302F-1</b>	0.2	0.08-0.50	0.05-0.15	○
	<b>CCGT09T304F-1</b>	0.4	0.08-0.50	0.05-0.20	○
	<b>CCGT09T308F-1</b>	0.8	0.08-0.50	0.05-0.25	○
	<b>CCGT120402F-1</b>	0.2	0.08-0.50	0.05-0.15	○
	<b>CCGT120404F-1</b>	0.4	0.08-0.50	0.05-0.20	○
	<b>CCGT120408F-1</b>	0.8	0.08-0.50	0.05-0.25	○
	<b>CCGT060204F-1MED</b>	0.4	0.08-0.50	0.05-0.20	○
	<b>CCGT060208F-1MED</b>	0.8	0.08-0.50	0.05-0.25	○
	<b>CCGT09T302F-1MED</b>	0.2	0.08-0.50	0.05-0.15	○
	<b>CCGT09T304F-1MED</b>	0.4	0.08-0.50	0.05-0.20	○
	<b>CCGT09T308F-1MED</b>	0.8	0.08-0.50	0.05-0.25	○

● Ex stock   ○ On demand DP Polycrystalline diamond

Tool holder						
SCACR/L	SCLCR/L	SCACR/L-SC	SCLCR/L-SC	A***-SCLCR/L	S***-SCFCR/L	S***-SCLCR
Kr: 90°	Kr: 95°	Kr: 90°	Kr: 95°	Kr: 95°	Kr: 90°	Kr: 95°
A269	A270	A306	A307	A334	A352	A353

**E\*\*\*-SCLCR/L**  
Kr: 95°

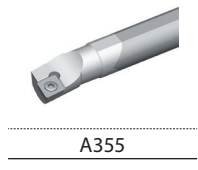

- Ideal machining conditions
- ⊗ Normal machining conditions
- ⊗ Unfavourable machining conditions

CCGT	L	I.C	S	d
09 T3	9.7	9.525	3.97	4.4
12 04	12.9	12.7	4.76	5.56

## Turning PCD inserts

CC** positive insert				DP	
				P	
				M	
				K	
				N	○
				S	
				H	
ISO	r	a <sub>p</sub>	f	YCD421	
<b>CCGT09T308-LL</b>	0.8	0.08-0.50	0.05-0.25	○	
<b>CCGT09T308-LR</b>	0.8	0.08-0.50	0.05-0.25	○	
<b>CCGT120404-LL</b>	0.4	0.08-0.50	0.05-0.20	○	
<b>CCGT120404-LR</b>	0.4	0.08-0.50	0.05-0.20	○	
<b>CCGT120408-LL</b>	0.8	0.08-0.50	0.05-0.25	○	
<b>CCGT120408-LR</b>	0.8	0.08-0.50	0.05-0.25	○	

● Ex stock   ○ On demand

DP Polycrystalline diamond

Tool holder						
SCACR/L	SCLCR/L	SCACR/L-SC	SCLCR/L-SC	A***-SCLCR/L	S***-SCFCR/L	S***-SCLCR
Kr: 90°	Kr: 95°	Kr: 90°	Kr: 95°	Kr: 95°	Kr: 90°	Kr: 95°
A269	A270	A306	A307	A334	A352	A353

E***-SCLCR/L
Kr: 95°
A355

A

Turning

B

Milling

C

Drilling

D

Technical Information

E

Index

**A**

Turning

**B**

Milling

**C**

Drilling

**D**

Technical Information

**E**

Index

- Ideal machining conditions
- ⊗ Normal machining conditions
- ⊗ Unfavourable machining conditions

CCGW	L	I.C	S	d
<b>06</b> 02	6.4	6.35	2.38	2.8
<b>09</b> T3	9.7	9.525	3.97	4.4
<b>12</b> 04	12.9	12.7	4.76	5.56

## Turning PCD inserts

CC** positive insert				DP		
				<b>P</b>		
				<b>M</b>		
				<b>K</b>		
				<b>N</b>	○	
				<b>S</b>		
				<b>H</b>		
ISO	r	a <sub>p</sub>	f	YCD421		
	<b>CCGW060202F-1</b>	0.2	0.08-0.50	0.05-0.15	○	
	<b>CCGW060204F-1</b>	0.4	0.08-0.50	0.05-0.20	○	
	<b>CCGW09T304F-1</b>	0.4	0.08-0.50	0.05-0.20	●	
	<b>CCGW09T308F-1</b>	0.8	0.08-0.50	0.05-0.25	●	
	<b>CCGW120404F-1</b>	0.4	0.08-0.50	0.05-0.20	●	
	<b>CCGW120408F-1</b>	0.8	0.08-0.50	0.05-0.25	●	

● Ex stock    ○ On demand

DP Polycrystalline diamond

**C**

Drilling

Tool holder						
SCACR/L	SCLCR/L	SCACR/L-SC	SCLCR/L-SC	A***-SCLCR/L	S***-SCFCR/L	S***-SCLCR
Kr: 90°	Kr: 95°	Kr: 90°	Kr: 95°	Kr: 95°	Kr: 90°	Kr: 95°
A269	A270	A306	A307	A334	A352	A353

**D**

Technical Information

E***-SCLCR/L
Kr: 95°
A355

System code > A158

Grade selection > A42

Technical info > A501

Cutting data > A366

## Turning PCD inserts

- Ideal machining conditions
- ⊗ Normal machining conditions
- ⊗ Unfavourable machining conditions

CCGW	L	I.C	S	d
<b>06</b> 02	6.4	6.35	2.38	2.8
<b>09</b> T3	9.7	9.525	3.97	4.4
<b>12</b> 04	12.9	12.7	4.76	5.56

CC** positive insert				DP																								
				<b>P</b>																								
				<b>M</b>																								
				<b>K</b>																								
				<b>N</b>	○																							
				<b>S</b>																								
				<b>H</b>																								
ISO	r	a <sub>p</sub>	f	YCD421																								
<b>CCGW060204-LL</b>	0.2	0.08-0.50	0.05-0.20	○																								
<b>CCGW060204-LR</b>	0.4	0.08-0.50	0.05-0.20	○																								
<b>CCGW09T304-LL</b>	0.4	0.08-0.50	0.05-0.20	○																								
<b>CCGW09T304-LR</b>	0.4	0.08-0.50	0.05-0.20	○																								
<b>CCGW09T308-LL</b>	0.8	0.08-0.50	0.05-0.25	○																								
<b>CCGW09T308-LR</b>	0.8	0.08-0.50	0.05-0.25	○																								
<b>CCGW120404-LL</b>	0.4	0.08-0.50	0.05-0.20	○																								
<b>CCGW120404-LR</b>	0.4	0.08-0.50	0.05-0.20	○																								
<b>CCGW120408-LL</b>	0.8	0.08-0.50	0.05-0.25	○																								
<b>CCGW120408-LR</b>	0.8	0.08-0.50	0.05-0.25	○																								

● Ex stock   ○ On demand

DP Polycrystalline diamond

Tool holder						
SCACR/L	SCLCR/L	SCACR/L-SC	SCLCR/L-SC	A***-SCLCR/L	S***-SCFCR/L	S***-SCLCR
Kr: 90°	Kr: 95°	Kr: 90°	Kr: 95°	Kr: 95°	Kr: 90°	Kr: 95°
A269	A270	A306	A307	A334	A352	A353

E***-SCLCR/L
Kr: 95°
A355

System code > A158

Grade selection > A42

Technical info > A501

Cutting data > A366





## A

### Turning

- Ideal machining conditions
- Normal machining conditions
- ☼ Unfavourable machining conditions

DCGT	L	I.C	S	d
<b>07 02</b>	7.8	6.35	2.38	2.8
<b>11 T3</b>	11.6	9.525	3.97	4.4

### Turning PCD inserts

DC** positive insert			DP														
	<b>P</b>	○															
	<b>M</b>	○															
	<b>K</b>	○															
	<b>N</b>	○															
	<b>S</b>	○															
<b>H</b>	○																

## B

### Milling

ISO		r	a <sub>p</sub>	f	YCD421														
	<b>DCGT070202F-1</b>	0.2	0.08-0.50	0.05-0.15	○														
	<b>DCGT070204F-1</b>	0.4	0.08-0.50	0.05-0.20	○														
	<b>DCGT11T302F-1</b>	0.2	0.08-0.50	0.05-0.15	●														
	<b>DCGT11T304F-1</b>	0.4	0.08-0.50	0.05-0.20	●														
	<b>DCGT11T308F-1</b>	0.8	0.08-0.50	0.05-0.25	○														

● Ex stock   ○ On demand

DP Polycrystalline diamond

## C

### Drilling

Tool holder						
SDACR/L	SDJCR/L	SDNCN	SDACR/L-SC	SDHCR/L-SC	SDJCR/L-SC	SDNCN-SC
Kr: 90°	Kr: 93°	Kr: 62°30'	Kr: 90°	Kr: 107°30'	Kr: 93°	Kr: 62°30'
A271	A272	A273	A308	A309	A310	A311

S***-SDQCR/L	A***-SDUCR/L	S***-SDZCR/L	E***-SDQCR/L
Kr: 107°30'	Kr: 93°	Kr: 85°	Kr: 107°30'
A336	A337	A338	A357

## D

### Technical Information

## E

### Index



- Ideal machining conditions
- ⊗ Normal machining conditions
- ⊗ Unfavourable machining conditions

DCGT	L	I.C	S	d
07 02	7.8	6.35	2.38	2.8
11 T3	11.6	9.525	3.97	4.4

## Turning PCD inserts

DC** positive insert		DP				
	<b>P</b>					
	<b>M</b>					
	<b>K</b>					
	<b>N</b>	○				
	<b>S</b>					
	<b>H</b>					

ISO	r	a <sub>p</sub>	f	YCD421
<b>DCGT070202F-1MED</b>	0.2	0.08-0.50	0.05-0.15	○
<b>DCGT070204F-1MED</b>	0.4	0.08-0.50	0.05-0.20	○
<b>DCGT070208F-1MED</b>	0.8	0.08-0.50	0.05-0.25	○
<b>DCGT11T302F-1MED</b>	0.2	0.08-0.50	0.05-0.15	○
<b>DCGT11T304F-1MED</b>	0.4	0.08-0.50	0.05-0.20	○
<b>DCGT11T308F-1MED</b>	0.8	0.08-0.50	0.05-0.25	○

● Ex stock    ○ On demand

DP Polycrystalline diamond

Tool holder						
SDACR/L	SDJCR/L	SDNCN	SDACR/L-SC	SDHCR/L-SC	SDJCR/L-SC	SDNCN-SC
Kr: 90°	Kr: 93°	Kr: 62°30'	Kr: 90°	Kr: 107°30'	Kr: 93°	Kr: 62°30'
A271	A272	A273	A308	A309	A310	A311

S***-SDQCR/L	A***-SDUCR/L	S***-SDZCR/L	E***-SDQCR/L
Kr: 107°30'	Kr: 93°	Kr: 85°	Kr: 107°30'
A336	A337	A338	A357

**A**

Turning

**B**

Milling

**C**

Drilling

**D**

Technical Information

**E**

Index

System code > A158

Grade selection > A42

Technical info > A501

Cutting data > A366



# General turning PCBN & PCD inserts



**A**

Turning

- Ideal machining conditions
- ⊗ Normal machining conditions
- ⊙ Unfavourable machining conditions

DCGW	L	I.C	S	d
07 02	7.8	6.35	2.38	2.8
11 T3	11.6	9.525	3.97	4.4

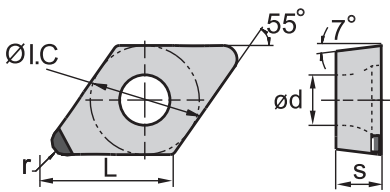
## Turning PCD inserts

DC** positive insert				DP																					
	P																								
	M																								
	K																								
	N	●																							
	S																								
	H																								
ISO	r	a <sub>p</sub>	f	YCD421																					
	<b>DCGW070202F-1</b>	0.2	0.08-0.50	0.05-0.15	●																				
	<b>DCGW070204F-1</b>	0.4	0.08-0.50	0.05-0.20	●																				
	<b>DCGW070208F-1</b>	0.8	0.08-0.50	0.05-0.25	○																				
	<b>DCGW11T302F-1</b>	0.2	0.08-0.50	0.05-0.15	●																				
	<b>DCGW11T304F-1</b>	0.4	0.08-0.50	0.05-0.20	●																				

● Ex stock ○ On demand DP Polycrystalline diamond

**B**

Milling

**C**





Drilling

**D**

Technical Information

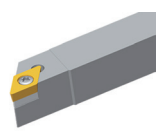
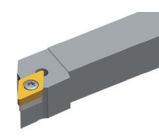
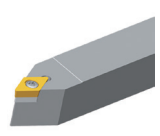
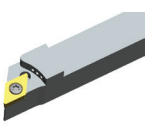
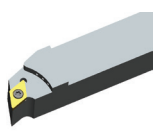
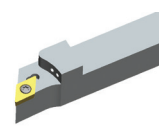
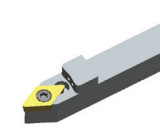
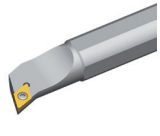
**E**

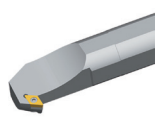

Index

Tool holder						
SDACR/L	SDJCR/L	SDNCN	SDACR/L-SC	SDHCR/L-SC	SDJCR/L-SC	SDNCN-SC
Kr: 90°	Kr: 93°	Kr: 62°30'	Kr: 90°	Kr: 107°30'	Kr: 93°	Kr: 62°30'
						
A271	A272	A273	A308	A309	A310	A311
S***-SDQCR/L	A***-SDUCR/L	S***-SDZCR/L	E***-SDQCR/L			
Kr: 107°30'	Kr: 93°	Kr: 85°	Kr: 107°30'			
						
A336	A337	A338	A357			





System code > A158    Grade selection > A42    Technical info > A501    Cutting data > A366



**Turning PCD inserts**

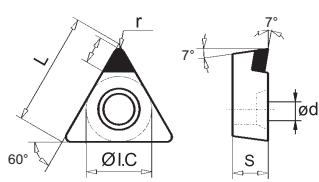

-  Ideal machining conditions
-  Normal machining conditions
-  Unfavourable machining conditions

TCGT	L	I.C	S	d
<b>11</b> 02	11	6.35	2.38	2.8
<b>16</b> T3	16.5	9.525	3.97	4.4

TC** positive insert				DP																					
				<b>P</b>																					
				<b>M</b>																					
				<b>K</b>																					
				<b>N</b>																					
				<b>S</b>																					
				<b>H</b>																					
ISO	r	a <sub>p</sub>	f	YCD421																					
	<b>TCGT110202F-1</b>	0.2	0.08-0.50	0.05-0.15	○																				
	<b>TCGT110204F-1</b>	0.4	0.08-0.50	0.05-0.20	○																				
	<b>TCGT110208F-1</b>	0.8	0.08-0.50	0.05-0.25	○																				
	<b>TCGT16T302F-1</b>	0.2	0.08-0.50	0.05-0.15	○																				
	<b>TCGT16T304F-1</b>	0.4	0.08-0.50	0.05-0.20	○																				
	<b>TCGT16T308F-1</b>	0.8	0.08-0.50	0.05-0.25	○																				
	<b>TCGT110202F-1MED</b>	0.2	0.08-0.50	0.05-0.15	○																				
	<b>TCGT110204F-1MED</b>	0.4	0.08-0.50	0.05-0.20	○																				
	<b>TCGT110208F-1MED</b>	0.8	0.08-0.50	0.05-0.25	○																				
	<b>TCGT16T302F-1MED</b>	0.2	0.08-0.50	0.05-0.15	○																				
	<b>TCGT16T304F-1MED</b>	0.4	0.08-0.50	0.05-0.20	○																				
	<b>TCGT16T308F-1MED</b>	0.8	0.08-0.50	0.05-0.25	○																				

● Ex stock ○ On demand

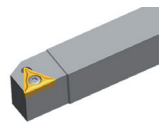
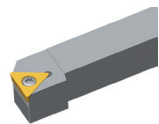
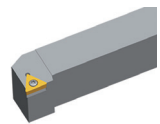
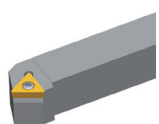
DP Polycrystalline diamond

Tool holder					
STACR/L	STFCR/L	STGCR/L	STTCR/L	S***-STFCR/L	E***-STFCR/L
Kr: 90°	Kr: 91°	Kr: 91°	Kr: 60°	Kr: 91°	Kr: 90°
					
A283	A284	A285	A286	A341	A361

System code > A158

Grade selection > A42

Technical info > A501

Cutting data > A366



**A**

Turning

**B**

Milling

**C**

Drilling

**D**



Technical Information

**E**

Index



A

Turning

-  Ideal machining conditions
-  Normal machining conditions
-  Unfavourable machining conditions



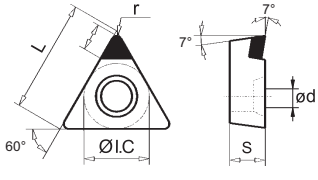



TCGT	L	I.C	S	d
11 02	11	6.35	2.38	2.8
16 T3	16.5	9.525	3.97	4.4

## Turning PCD inserts

TC** positive insert		DP														
		<b>P</b>														
		<b>M</b>														
		<b>K</b>														
		<b>N</b>														
		<b>S</b>														
		<b>H</b>														

B

Milling

ISO	r	a <sub>p</sub>	f	YCD421	DP											
						<b>TCGT110202-L</b>	0.2	0.08-0.50	0.05-0.15							
	<b>TCGT110204-L</b>	0.4	0.08-0.50	0.05-0.20												
	<b>TCGT110208-L</b>	0.8	0.08-0.50	0.05-0.25												
	<b>TCGT16T302-L</b>	0.2	0.08-0.50	0.05-0.15												
	<b>TCGT16T304-L</b>	0.4	0.08-0.50	0.05-0.20												
	<b>TCGT16T308-L</b>	0.8	0.08-0.50	0.05-0.25												

● Ex stock ○ On demand

DP Polycrystalline diamond

C

Drilling

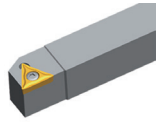
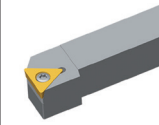
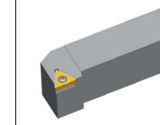
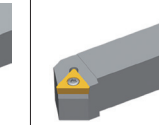
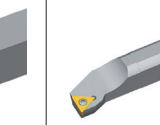
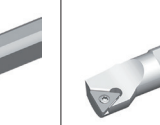
Tool holder					
STACR/L	STFCR/L	STGCR/L	STTCR/L	S***-STFCR/L	E***-STFCR/L
Kr: 90°	Kr: 91°	Kr: 91°	Kr: 60°	Kr: 91°	Kr: 90°
					
A283	A284	A285	A286	A341	A361

D

Technical Information

E

Index



System code > A158

Grade selection > A42







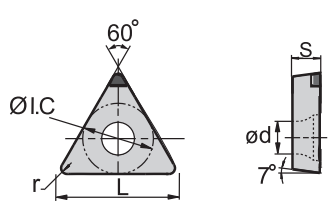

Technical info > A501

Cutting data > A366

## Turning PCD inserts



-  Ideal machining conditions
-  Normal machining conditions
-  Unfavourable machining conditions

TCGW	L	I.C	S	d
11 02	11	6.35	2.38	2.8
16 T3	16.5	9.525	3.97	4.4

TC** positive insert				DP																						
				<b>P</b>																						
				<b>M</b>																						
				<b>K</b>																						
				<b>N</b>																						
				<b>S</b>																						
				<b>H</b>																						
ISO	r	a <sub>p</sub>	f	YCD421																						
	<b>TCGW110202F-1</b>	0.2	0.08-0.50	0.05-0.15																						
	<b>TCGW110204F-1</b>	0.4	0.08-0.50	0.05-0.20																						
	<b>TCGW110208F-1</b>	0.8	0.08-0.50	0.05-0.25																						
	<b>TCGW16T304F-1</b>	0.4	0.08-0.50	0.05-0.20																						
	<b>TCGW16T308F-1</b>	0.8	0.08-0.50	0.05-0.25																						
	<b>TCGW16T312F-1</b>	1.2	0.08-0.50	0.05-0.30																						

● Ex stock    ○ On demand

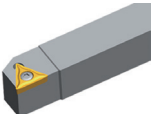
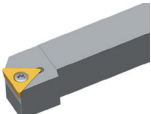
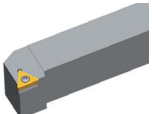
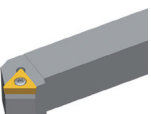
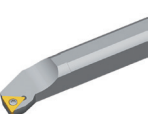
DP Polycrystalline diamond

Tool holder					
STACR/L	STFCR/L	STGCR/L	STTCR/L	S***-STFCR/L	E***-STFCR/L
Kr: 90°	Kr: 91°	Kr: 91°	Kr: 60°	Kr: 91°	Kr: 90°
					
A283	A284	A285	A286	A341	A361

System code > A158

Grade selection > A42

Technical info > A501

Cutting data > A366



A

Turning

B

Milling

C

Drilling

D

Technical Information

E

Index

**A**

Turning

- Ideal machining conditions
- Normal machining conditions
- Unfavourable machining conditions

TCGW	L	I.C	S	d
11 02	11	6.35	2.38	2.8
16 T3	16.5	9.525	3.97	4.4

### Turning PCD inserts

TC** positive insert		DP																
	<b>P</b>																	
	<b>M</b>																	
	<b>K</b>																	
	<b>N</b>	<span style="color: #00aaff;">●</span>																
	<b>S</b>																	
	<b>H</b>																	

**B**

Milling

ISO	r	a <sub>p</sub>	f	YCD421	DP													
						<b>TCGW110202-L</b>	0.2	0.08-0.50	0.05-0.15	<span style="color: #00aaff;">○</span>								
	<b>TCGW110204-L</b>	0.4	0.08-0.50	0.05-0.20	<span style="color: #00aaff;">○</span>													
	<b>TCGW110208-L</b>	0.8	0.08-0.50	0.05-0.25	<span style="color: #00aaff;">○</span>													
	<b>TCGW16T302-L</b>	0.2	0.08-0.50	0.05-0.15	<span style="color: #00aaff;">○</span>													
	<b>TCGW16T304-L</b>	0.4	0.08-0.50	0.05-0.20	<span style="color: #00aaff;">○</span>													
	<b>TCGW16T308-L</b>	0.8	0.08-0.50	0.05-0.25	<span style="color: #00aaff;">○</span>													

● Ex stock    ○ On demand

DP Polycrystalline diamond

**C**

Drilling

Tool holder					
STACR/L	STFCR/L	STGCR/L	STTCR/L	S***-STFCR/L	E***-STFCR/L
Kr: 90°	Kr: 91°	Kr: 91°	Kr: 60°	Kr: 91°	Kr: 90°
A283	A284	A285	A286	A341	A361

**D**

Technical Information

**E**

Index



System code &gt; A158

Grade selection &gt; A42











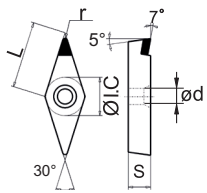

Technical info &gt; A501

Cutting data &gt; A366

## Turning PCD inserts



-  Ideal machining conditions
-  Normal machining conditions
-  Unfavourable machining conditions

VBGT	L	I.C	S	d
11 03	11	6.35	3.18	2.8
16 04	16.6	9.525	4.76	4.4

VB** positive insert				DP																							
				<b>P</b>																							
				<b>M</b>																							
				<b>K</b>																							
				<b>N</b>																							
				<b>S</b>																							
				<b>H</b>																							
ISO	r	a <sub>p</sub>	f	YCD421																							
	<b>VBGT110302F-1</b>	0.2	0.08-0.50	0.05-0.15																							
	<b>VBGT110304F-1</b>	0.4	0.08-0.50	0.05-0.20																							
	<b>VBGT110308F-1</b>	0.8	0.08-0.50	0.05-0.25																							
	<b>VBGT160402F-1</b>	0.2	0.08-0.50	0.05-0.15																							
	<b>VBGT160404F-1</b>	0.4	0.08-0.50	0.05-0.20																							
	<b>VBGT160408F-1</b>	0.8	0.08-0.50	0.05-0.25																							
	<b>VBGT160404F-1MED</b>	0.4	0.08-0.50	0.05-0.20																							
	<b>VBGT160408F-1MED</b>	0.8	0.08-0.50	0.05-0.25																							

● Ex stock    ○ On demand

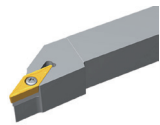
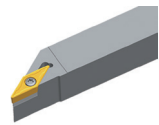
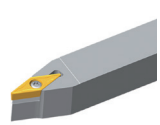
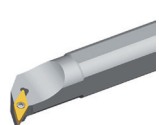
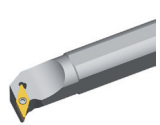
DP Polycrystalline diamond

Tool holder					
<b>SVJBR/L</b>	<b>SVABR/L</b>	<b>SVVBN</b>	<b>S***-SVQBR/L</b>	<b>S***-SVUBR/L</b>	<b>S***-SVXBR/L</b>
Kr: 93°	Kr: 90°	Kr: 72°30'	Kr: 107°30'	Kr: 93°	Kr: 93°
					
A274	A275	A276	A345	A346	A347

System code > A158

Grade selection > A42

Technical info > A501

Cutting data > A366







# General turning PCBN & PCD inserts



## A

Turning

-  Ideal machining conditions
-  Normal machining conditions
-  Unfavourable machining conditions



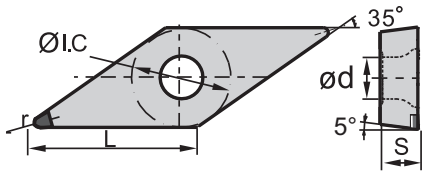



VBGW	L	I.C	S	d
11 03	11	6.35	3.18	2.8
16 04	16.6	9.525	4.76	4.4

### Turning PCD inserts

VB** positive insert		DP																		
	<b>P</b>																			
	<b>M</b>																			
	<b>K</b>																			
	<b>N</b>																			
	<b>S</b>																			
	<b>H</b>																			

## B

Milling



	ISO	r	a <sub>p</sub>	f	YCD421																
	<b>VBGW110302F-1</b>	0.2	0.08-0.50	0.05-0.15																	
	<b>VBGW110304F-1</b>	0.4	0.08-0.50	0.05-0.20																	
	<b>VBGW160402F-1</b>	0.2	0.08-0.50	0.05-0.15																	
	<b>VBGW160404F-1</b>	0.4	0.08-0.50	0.05-0.20																	
	<b>VBGW160408F-1</b>	0.8	0.08-0.50	0.05-0.25																	

● Ex stock ○ On demand

DP Polycrystalline diamond

## C

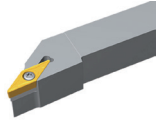
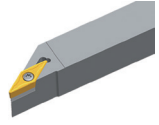
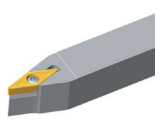
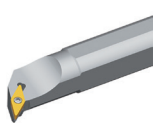
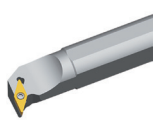
Drilling

Tool holder					
SVJBR/L	SVABR/L	SVVBN	S***-SVQBR/L	S***-SVUBR/L	S***-SVXBR/L
Kr: 93°	Kr: 90°	Kr: 72°30'	Kr: 107°30'	Kr: 93°	Kr: 93°
					
A274	A275	A276	A345	A346	A347

## D

Technical Information

## E

Index

System code > A158

Grade selection > A42

Technical info > A501

Cutting data > A366

- Ideal machining conditions
- Normal machining conditions
- Unfavourable machining conditions

VCGT	L	I.C	S	d
11 02	11	6.35	2.38	2.8
16 04	16.6	9.525	4.76	4.4

**Turning PCD inserts**

VC** positive insert				DP																					
				P																					
				M																					
				K																					
				N	○																				
				S																					
				H																					
ISO	r	a <sub>p</sub>	f	YCD421																					
	<b>VCGT110202F-1</b>	0.2	0.08-0.50	0.05-0.15	○																				
	<b>VCGT110204F-1</b>	0.4	0.08-0.50	0.05-0.20	○																				
	<b>VCGT160402F-1</b>	0.2	0.08-0.50	0.05-0.15	○																				
	<b>VCGT160404F-1</b>	0.4	0.08-0.50	0.05-0.20	○																				
	<b>VCGT160408F-1</b>	0.8	0.08-0.50	0.05-0.25	○																				

● Ex stock    ○ On demand

DP Polycrystalline diamond

Tool holder						
SVVCN	SVJCR/L	SVACR/L-SC	SVJCR/L-SC	S***-SVQCR/L	S***-SVUCR/L	C***-SVQCR/L
Kr: 72°30'	Kr: 93°	Kr: 90°	Kr: 93°	Kr: 107°30'	Kr: 93°	Kr: 107°30'
A277	A278	A312	A313	A343	A344	A363

C***-SVUCR/L
Kr: 93°
A364

A

Turning

## Turning PCD inserts

- Ideal machining conditions
- ⊗ Normal machining conditions
- ⊗ Unfavourable machining conditions

VCGT	L	I.C	S	d
11 03	11	6.35	3.18	2.8
16 04	16.6	9.525	4.76	4.4

VC** positive insert		DP									
	<b>P</b>										
	<b>M</b>										
	<b>K</b>										
	<b>N</b>	○									
	<b>S</b>										
	<b>H</b>										

B

Milling

ISO	r	a <sub>p</sub>	f	YCD421												
						<b>VCGT110302F-1MED</b>	0.2	0.08-0.50	0.05-0.15	○						
	<b>VCGT110304F-1MED</b>	0.4	0.08-0.50	0.05-0.20	○											
	<b>VCGT160404F-1MED</b>	0.4	0.08-0.50	0.05-0.20	○											
	<b>VCGT160408F-1MED</b>	0.8	0.08-0.50	0.05-0.25	○											
	<b>VCGT160412F-1MED</b>	1.2	0.08-0.50	0.05-0.30	○											

● Ex stock    ○ On demand    DP Polycrystalline diamond

C

Drilling

Tool holder						
SVVCN	SVJCR/L	SVACR/L-SC	SVJCR/L-SC	S***-SVQCR/L	S***-SVUCR/L	C***-SVQCR/L
Kr: 72°30'	Kr: 93°	Kr: 90°	Kr: 93°	Kr: 107°30'	Kr: 93°	Kr: 107°30'
A277	A278	A312	A313	A343	A344	A363

C***-SVUCR/L
Kr: 93°
A364

D

Technical Information

E

Index



- Ideal machining conditions
- ⊗ Normal machining conditions
- ⊗ Unfavourable machining conditions

VCGW	L	I.C	S	d
11 03	11	6.35	3.18	2.8
16 04	16.6	9.525	4.76	4.4

## Turning PCD inserts

VC** positive insert				DP																						
				P																						
				M																						
				K																						
				N	○																					
				S																						
				H																						
ISO	r	a <sub>p</sub>	f	YCD421																						
	<b>VCGW110302F-1</b>	0.2	0.08-0.50	0.05-0.15	○																					
	<b>VCGW110304F-1</b>	0.4	0.08-0.50	0.05-0.20	○																					
	<b>VCGW160404F-1</b>	0.4	0.08-0.50	0.05-0.20	○																					
	<b>VCGW160408F-1</b>	0.8	0.08-0.50	0.05-0.25	○																					

● Ex stock   ○ On demand

DP Polycrystalline diamond

Tool holder						
SVVCN	SVJCR/L	SVACR/L-SC	SVJCR/L-SC	S***-SVQCR/L	S***-SVUCR/L	C***-SVQCR/L
Kr: 72°30'	Kr: 93°	Kr: 90°	Kr: 93°	Kr: 107°30'	Kr: 93°	Kr: 107°30'
A277	A278	A312	A313	A343	A344	A363

C***-SVUCR/L
Kr: 93°
A364

A

Turning

B

Milling

C

Drilling

D

Technical Information

E

Index

System code > A158

Grade selection > A42

Technical info > A501

Cutting data > A366



**A**

Turning

- Ideal machining conditions
- ⊗ Normal machining conditions
- ⊗ Unfavourable machining conditions

VCGX	L	I.C	S	d
<b>22 05</b>	22	12.7	5.56	5.5

## Turning PCD inserts

VC** positive insert				DP																			
	P																						
	M																						
	K																						
	N	●																					
	S																						
H																							

**B**

Milling

ISO	r	a <sub>p</sub>	f	YCD421																		
<b>VCGX220530-1</b>	3	0.5-7.0	0.25-1.00	○																		

● Ex stock    ○ On demand

DP Polycrystalline diamond

**C**

Drilling

**D**

Technical Information

**E**

Index





## T N G A 12 04 08 T 020 20

1 2 3 4 5 6 7 8 9 10

A

Turning

B

Milling

C















Drilling









D

Technical Information

E

Index

Insert shape		
A 	B 	C 
D 	E 	H 
K 	L 	M 
P 	S 	T 
V 	W 	Z Special



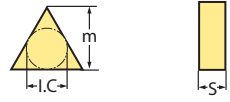



Clearance angle	
A 	B 
C 	D 
E 	F 
G 	N 
P 	O Special







Tolerance class			
			
Code	I.C [mm]	m [mm]	S [mm]
A	±0,025	±0,005	±0,025
C	±0,025	±0,013	±0,025
E	±0,025	±0,025	±0,025
F	±0,013	±0,005	±0,025
G	±0,025	±0,025	±0,130
H	±0,013	±0,013	±0,025
J	±0,05-0,15	±0,005	±0,025
K	±0,05-0,15	±0,013	±0,025
L	±0,05-0,15	±0,025	±0,025
M	±0,05-0,15	±0,08-0,20	±0,130
N	±0,05-0,15	±0,08-0,20	±0,025
U	±0,08-0,25	±0,13-0,38	±0,130

1

2

3

Fastening features (metric)	
Insert shape	
A 	B 
C 	N 
Q 	W 
X	Special

Cutting edge length l [mm]						
I.C [mm]	Insert shape					
						
3,97				06		
5,0				09		
5,56				09		
6,0				09		
6,35	06	07		11	11	
8,0				09		
9,525	09	11	09	16	16	06
10,0				09		
12,0				09		
12,7	12	15	12	22	22	08
15,875	16		15	27		
16,0		19				
19,05	19		19	33		
20,0				09		
25,0	25	25				
25,4			25			
31,75				09		
32				09		

4



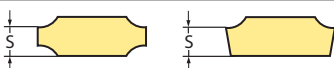

5

Insert thickness S [mm]			
			
Code	S	Code	S
02	2,38	06	6,35
T2	2,58	T6	6,75
03	3,18	07	7,94
T3	3,97	09	9,52
04	4,76	T9	9,72
T4	4,96	11	11,11
05	5,56	12	12,70
T5	5,95		

**6**

Nose radius r [mm]	
	
Code	r
00	–
02	0,2
04	0,4
08	0,8
12	1,2
16	1,6
20	2,0
24	2,4
32	3,2
X	Special
MO	Plaquettes rondes

**7**

Cutting edge profile		
Code	Cutting edge	Insert shape
E	Rounding	
F	Sharp edge	
T	Chamfer	
S	Chamfer + Rounding	

**8**

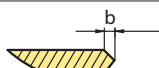
Chamfer width b [mm]	
	
Code	b
010	0,10
015	0,15
020	0,20
025	0,25
030	0,30
035	0,35
040	0,40
045	0,45
050	0,50
100	1,00
200	2,00

**9**

Angle du chanfrein $\alpha$	
	
Code	$\alpha$
05	5°
10	10°
15	15°
20	20°
25	25°
30	30°

**10**

**A**

Turning

**B**

Milling

**C**

Drilling

**D**

Technical Information

**E**

Index



**A**

Turning

**B**

Milling

**C**

Drilling

**D**

Technical Information

**E**

Index

- Ideal machining conditions
- ⊗ Normal machining conditions
- ⊗ Unfavourable machining conditions

CNGA	L	I.C	S	d
12 04	12.9	12.7	4.76	5.16
16 06	16.1	15.875	6.35	6.35

## Turning ceramic inserts

CN** negative insert		CM	CC	CN	CR
	<b>P</b>	●			
	<b>M</b>				
	<b>K</b>	●		⊗	
	<b>N</b>				
	<b>S</b>			●	⊗
	<b>H</b>		○		

ISO	r	a <sub>p</sub>	f	CA1000	CM1000	CN1000 CS1000	CW1400 CW1800
<b>CNGA120404S02020</b>	0.4	0.1-0.3	0.08-0.25		●		
<b>CNGA120404T01020</b>	0.4	0.1-0.3	0.08-0.25		○		
<b>CNGA120404T02020</b>	0.4	0.1-0.3	0.08-0.25	○	●	●	
<b>CNGA120408S01520</b>	0.8	0.1-0.25	0.5-2.5				○
<b>CNGA120408S02020</b>	0.8	0.1-0.4	0.1-0.3		●		
<b>CNGA120408T00520</b>	0.8	0.1-0.25	0.5-2.5				○ ●
<b>CNGA120408T01020</b>	0.8	0.1-0.4	0.1-0.3		○		
<b>CNGA120408T02020</b>	0.8	0.1-0.4	0.1-0.3	○	●	○	
<b>CNGA120412S01520</b>	1.2	0.1-0.3	0.5-2.5				○
<b>CNGA120412S02020</b>	1.2	0.1-0.5	0.1-0.3		●		
<b>CNGA120412T00520</b>	1.2	0.1-0.3	0.5-2.5				○
<b>CNGA120412T02020</b>	1.2	0.1-0.5	0.1-0.3	○	○	●	
<b>CNGA120416S01520</b>	1.6	0.1-0.35	0.5-3.0				○
<b>CNGA120416T00520</b>	1.6	0.1-0.35	0.5-3.0				○ ○
<b>CNGA160612T02020</b>	1.2	0.2-2.0	0.1-0.3			●	

● Ex stock   ○ On demand

CM Mixed ceramic  
 CC Mixed ceramic, coated  
 CN Si3N4 Ceramic  
 CR Al2O3 cutting ceramic, reinforced

**D**

Technical Information

Tool holder					
DCLNR/L	PCBNR/L	PCLNR/L	MCBNR/L	MCLNR/L	S***-PCLNR/L
Kr: 95°	Kr: 75°	Kr: 95°	Kr: 75°	Kr: 95°	Kr: 95°
A230	A237	A238	A252	A253	A324

**E**

Index



CNGN	L	I.C	S
12 07	12.9	12.7	7.94
12 04	12.9	12.7	4.76
16 06	16.1	15.875	6.35
16 07	16.1	15.875	7.94

- Ideal machining conditions
- ⊗ Normal machining conditions
- ⊗ Unfavourable machining conditions

**Turning ceramic inserts**

CN** negative insert				CM	CC	CN	CR
	<b>P</b>	<span style="color: blue;">●</span>					
	<b>M</b>						
	<b>K</b>	<span style="color: red;">●</span>			<span style="color: red;">⊗</span>		
	<b>N</b>						
	<b>S</b>					<span style="color: orange;">●</span>	<span style="color: orange;">⊗</span>
	<b>H</b>				<span style="color: grey;">○</span>		

ISO	r	a <sub>p</sub>	f	CA1000	CM1000	CN1000 CS1000	CW1400 CW1800
CNGN120404T00520	0.4	0.1-0.25	0.5-2.0				○
CNGN120404T02020	0.4	0.1-0.3	0.08-0.25	○			
CNGN120408S01520	0.8	0.1-0.25	0.5-2.5				○
CNGN120408S02020	0.8	0.1-0.4	0.1-0.3		○		
CNGN120408T00520	0.8	0.1-0.25	0.5-2.5				●
CNGN120408T02020	0.8	0.1-0.4	0.1-0.3	●		●	
CNGN120412S01520	1.2	0.1-0.3	0.5-2.5				○
CNGN120412T00520	1.2	0.1-0.3	0.5-2.5				●
CNGN120412T02020	1.2	0.1-0.5	0.1-0.3	○		○	
CNGN120416S01520	1.6	0.1-0.35	0.5-3.0				○
CNGN120416T00520	1.6	0.1-0.35	0.5-3.0				●
CNGN120416T02020	1.6	0.5-2.0	0.1-0.35			○	
CNGN120708S01520	0.8	0.1-0.25	0.5-2.5				○
CNGN120708T00520	0.8	0.1-0.25	0.5-2.5				●
CNGN120708T02020	0.8	0.1-0.4	0.1-0.3	○			
CNGN120712S01520	1.2	0.1-0.3	0.5-2.5				○
CNGN120712S02025	1.2	0.1-0.3	0.5-2.5				○
CNGN120712T00520	1.2	0.1-0.3	0.5-2.5				●
CNGN120712T00525	1.2	0.1-0.3	0.5-2.5			○	○
CNGN120712T02020	1.2	0.1-0.5	0.1-0.3	●		○	
CNGN120716S01520	1.6	0.1-0.35	0.5-3.0				○
CNGN120716T00520	1.6	0.1-0.35	0.5-3.0				○
CNGN120716T01520	1.6	0.1-0.35	0.5-3.0				○
CNGN120716T02020	1.6	0.1-0.6	0.1-0.4	○		○	
CNGN160616T02020	1.6	0.1-0.6	0.1-0.4	○			
CNGN160712T01525	1.2	0.2-2.0	0.1-0.3			○	
CNGN160716T01525	1.6	0.1-0.6	0.1-0.4	○			
CNGN160716T02020	1.6	0.5-2.0	0.1-0.35			○	

● Ex stock    ○ On demand

CM Mixed ceramic  
 CC Mixed ceramic, coated  
 CN Si3N4 Ceramic  
 CR Al2O3 cutting ceramic, reinforced



**A**

Turning

**B**

Milling

**C**

Drilling

**D**

Technical Information

**E**

Index

**A**

Tool holder

CCLNR/L

Kr: 95°



A292

Turning

**B**

Milling

**C**

Drilling

**D**

Technical  
Information

**E**

Index

System code > A198

Grade selection > A42

Technical info > A501

Cutting data > A366

- Ideal machining conditions
- ⊗ Normal machining conditions
- ⊗ Unfavourable machining conditions

CNGX	L	I.C	S
12 07	12.9	12.7	7.94

**Turning ceramic inserts**

CN** negative insert					CM	CC	CN	CR
	<b>P</b>	●						
	<b>M</b>							
	<b>K</b>	●				⊗		
	<b>N</b>							
	<b>S</b>						●	⊗
	<b>H</b>					○		
ISO	r	a <sub>p</sub>	f	CA1000	CM1000	CN1000 CS1000	CW1400 CW1800	
	<b>CNGX120712T02020</b>	1.2	0.2-2.0	0.1-0.3		●		
	<b>CNGX120716T02020</b>	1.6	0.5-2.0	0.1-0.35		○		

● Ex stock   ○ On demand

CM Mixed ceramic  
 CC Mixed ceramic, coated  
 CN Si3N4 Ceramic  
 CR Al2O3 cutting ceramic, reinforced

Tool holder  
**JCLNR/L**  
 Kr: 95°

A300

**A**

Turning

**B**

Milling

**C**

Drilling

**D**

Technical Information

**E**

Index



**A**

Turning

**B**

Milling

**C**

Drilling

**D**

Technical Information

**E**

Index

- Ideal machining conditions
- ⊗ Normal machining conditions
- ⊗ Unfavourable machining conditions

DNGA	L	I.C	S	d
15 06	15.5	12.7	6.35	5.16
15 04	15.5	12.7	4.76	5.16

## Turning ceramic inserts

DN** negative insert				CM	CC	CN	CR
	<b>P</b>	●					
	<b>M</b>						
	<b>K</b>	●			⊗		
	<b>N</b>						
	<b>S</b>					●	⊗
	<b>H</b>				○		
ISO	r	a <sub>p</sub>	f	CA1000	CM1000	CN1000 CS1000	CW1400 CW1800
<b>DNGA150404T02020</b>	0.4	0.1-0.3	0.08-0.25		○		
<b>DNGA150408S01520</b>	0.8	0.1-0.25	0.5-2.5				○
<b>DNGA150408T00520</b>	0.8	0.1-0.25	0.5-2.5				●
<b>DNGA150408T02020</b>	0.8	0.1-0.4	0.1-0.3		○		
<b>DNGA150412S01520</b>	1.2	0.1-0.3	0.5-2.5				○
<b>DNGA150412T00520</b>	1.2	0.1-0.3	0.5-2.5				●
<b>DNGA150412T02020</b>	1.2	0.1-0.5	0.1-0.3		○	○	○
<b>DNGA150416S01520</b>	1.6	0.1-0.35	0.5-3.0				○
<b>DNGA150416T00520</b>	1.6	0.1-0.35	0.5-3.0				○
<b>DNGA150604S02020</b>	0.4	0.1-0.3	0.08-0.25		●		
<b>DNGA150604T01020</b>	0.4	0.1-0.3	0.08-0.25		○		
<b>DNGA150604T02020</b>	0.4	0.1-0.3	0.08-0.25		●	○	
<b>DNGA150608S02020</b>	0.8	0.1-0.4	0.1-0.3		●		
<b>DNGA150608T02020</b>	0.8	0.1-0.4	0.1-0.3		○	●	
<b>DNGA150612S02020</b>	1.2	0.1-0.5	0.1-0.3		●		
<b>DNGA150612T01020</b>	1.2	0.1-0.5	0.1-0.3		○		
<b>DNGA150612T02020</b>	1.2	0.1-0.5	0.1-0.3		●	○	
<b>DNGA150616T02020</b>	1.6	0.5-2.0	0.1-0.35			○	

● Ex stock    ○ On demand

CM Mixed ceramic  
 CC Mixed ceramic, coated  
 CN Si3N4 Ceramic  
 CR Al2O3 cutting ceramic, reinforced

Tool holder						
DDJNR/L	PDJNR/L	PDNNR/L	MDJNR/L	MDPNN	S***-PDSNR/L	S***-PDUNR/L
Kr: 93°	Kr: 93°	Kr: 63°	Kr: 93°	Kr: 62°30'	Kr: 62°30'	Kr: 93°
A231	A240	A241	A254	A255	A326	A327



- Ideal machining conditions
- Normal machining conditions
- Unfavourable machining conditions

DNGN	L	I.C	S
15 04	15.5	12.7	4.76
15 07	15.5	12.7	7.94

**Turning ceramic inserts**

DN** negative insert				CM	CC	CN	CR
	<b>P</b>	●					
	<b>M</b>						
	<b>K</b>	●			●		
	<b>N</b>						
	<b>S</b>					●	●
	<b>H</b>				○		

ISO	r	a <sub>p</sub>	f	CA1000		CM1000	CN1000 CS1000	CW1400 CW1800
				○	○	○	○	○
<b>DNGN150408S01520</b>	0.8	0.1-0.25	0.5-2.5					○
<b>DNGN150408T00520</b>	0.8	0.1-0.25	0.5-2.5					●
<b>DNGN150408T02020</b>	0.8	0.1-0.4	0.1-0.3	○		○		
<b>DNGN150412S01520</b>	1.2	0.1-0.3	0.5-2.5					○
<b>DNGN150412T00520</b>	1.2	0.1-0.3	0.5-2.5					●
<b>DNGN150412T02020</b>	1.2	0.1-0.5	0.1-0.3	○				
<b>DNGN150416S01520</b>	1.6	0.1-0.35	0.5-3.0					○
<b>DNGN150416T00520</b>	1.6	0.1-0.35	0.5-3.0					○
<b>DNGN150704T02020</b>	0.4	0.1-0.3	0.08-0.25	○			○	
<b>DNGN150708T01520</b>	0.8	0.1-0.25	0.5-2.5					○
<b>DNGN150708T02020</b>	0.8	0.1-0.4	0.1-0.3	●			○	
<b>DNGN150712T02020</b>	1.2	0.1-0.5	0.1-0.3	○			○	
<b>DNGN150716T01520</b>	1.6	0.1-0.35	0.5-3.0					○
<b>DNGN150716T02020</b>	1.6	0.1-0.6	0.1-0.4	○				

● Ex stock ○ On demand

CM Mixed ceramic  
 CC Mixed ceramic, coated  
 CN Si3N4 Ceramic  
 CR Al2O3 cutting ceramic, reinforced

Tool holder  
**CDJNR/L**  
 Kr: 93°

A294

**A**

Turning

**B**

Milling

**C**

Drilling

**D**

Technical Information

**E**

Index



**A**

Turning

- Ideal machining conditions
- ⊗ Normal machining conditions
- ⊗ Unfavourable machining conditions

DNGX	L	I.C	S
15 07	15.5	12.7	7.94

## Turning ceramic inserts

DN** negative insert				CM	CC	CN	CR
	<b>P</b>	<span style="color: blue;">●</span>					
	<b>M</b>						
	<b>K</b>	<span style="color: red;">●</span>			<span style="color: red;">⊗</span>		
	<b>N</b>						
	<b>S</b>	<span style="color: orange;">●</span>			<span style="color: orange;">●</span>	<span style="color: orange;">⊗</span>	<span style="color: orange;">⊗</span>
	<b>H</b>				<span style="color: grey;">○</span>		
ISO	r	a <sub>p</sub>	f	CA1000	CM1000	CN1000 CS1000	CW1400 CW1800
	<b>DNGX150708T02020</b>	0.8	0.15-1.5	0.1-0.25		<span style="color: grey;">○</span>	
	<b>DNGX150712T02020</b>	1.2	0.2-2.0	0.1-0.3		<span style="color: grey;">○</span>	
	<b>DNGX150716T02020</b>	1.6	0.5-2.0	0.1-0.35		<span style="color: grey;">○</span>	

● Ex stock    ○ On demand

- CM Mixed ceramic
- CC Mixed ceramic, coated
- CN Si3N4 Ceramic
- CR Al2O3 cutting ceramic, reinforced

**B**

Milling

**C**

Drilling

**D**

Technical Information

**E**

Index

Tool holder

**JDJNR/L**

Kr: 93°

A301



- Ideal machining conditions
- ⊗ Normal machining conditions
- ⊗ Unfavourable machining conditions

RNGA	I.C	S	d
12 04	12.7	4.76	

**Turning ceramic inserts**

RN** negative insert			CM	CC	CN	CR
	<b>P</b>	●				
	<b>M</b>	●				
	<b>K</b>	●			⊗	
	<b>N</b>	●				
	<b>S</b>	●			●	⊗
	<b>H</b>	●		○		
ISO	a <sub>p</sub>	f	CA1000	CM1000	CN1000 CS1000	CW1400 CW1800
	<b>RNGA120400T02020</b>	0.1-0.6	0.1-0.4	○	○	

● Ex stock   ○ On demand

CM Mixed ceramic  
 CC Mixed ceramic, coated  
 CN Si3N4 Ceramic  
 CR Al2O3 cutting ceramic, reinforced

Tool holder	
MRDNN	MRGNR/L
A267	A268

**A**

Turning

**B**

Milling

**C**

Drilling

**D**

Technical Information

**E**



Index



**A**

Turning







RNGN	I.C	S
06 03	6.35	3.18
09 04	9.525	4.76
09 03	9.525	3.18
12 07	12.7	7.94
12 04	12.7	4.76
15 07	15.875	7.94
19 07	19.05	7.94
25 07	25.4	7.94
25 10	25.4	10.05

-  Ideal machining conditions
-  Normal machining conditions
-  Unfavourable machining conditions

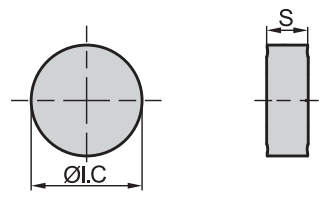
## Turning ceramic inserts

**B**

Milling

RN** negative insert		CM	CC	CN	CR
	<b>P</b>				
	<b>M</b>				
	<b>K</b>				
	<b>N</b>				
	<b>S</b>				
	<b>H</b>				

**C**

Drilling

ISO	a <sub>p</sub>	f	CA1000		CM1000		CN1000 CS1000		CW1400 CW1800	
			○	●	○	●	○	●	○	●
RNGN060300T01020	0.1-0.3	0.08-0.25	○		○					
RNGN090300S01520	0.1-0.3	0.5-2.5							○	
RNGN090300T00520	0.1-0.3	0.5-2.5							○	○
RNGN090300T02020	0.1-0.3	0.1-0.3	○							
RNGN090400S01520	0.1-0.3	0.5-2.5							○	
RNGN090400T00520	0.1-0.3	0.5-2.5							○	
RNGN090400T02020	0.1-0.3	0.1-0.3	○							
RNGN120400S01520	0.1-0.35	0.5-3.0							○	
RNGN120400S02020	0.1-0.6	0.1-0.4			●					
RNGN120400T00520	0.1-0.35	0.5-3.0							●	
RNGN120400T01020	0.5-2.0	0.1-0.2					○			
RNGN120400T01525	0.1-0.6	0.1-0.4			○					
RNGN120400T02020	0.1-0.6	0.1-0.4	○				○			○
RNGN120700S01520	0.1-0.35	0.5-3.0							○	
RNGN120700S02020	0.1-0.6	0.1-0.4			●					
RNGN120700T00520	0.1-0.35	0.5-3.0							●	●
RNGN120700T00525	0.1-0.35	0.5-3.0					○		○	○
RNGN120700T01520	0.1-0.35	0.5-3.0							○	
RNGN120700T01525	0.2-2.0	0.1-0.3					○			
RNGN120700T02020	0.2-2.0	0.1-0.3	●				●			
RNGN150700T02020	0.1-0.6	0.1-0.5	○							
RNGN190700S01520	0.1-0.4	0.5-3.0							○	
RNGN190700T00520	0.1-0.4	0.5-3.0							○	
RNGN190700T03020	0.1-0.7	0.1-0.5	○							
RNGN250700T19015	0.1-0.7	0.1-0.8	○							
RNGN251000T05020	0.1-0.7	0.1-0.5	○							

● Ex stock    ○ On demand

CM Mixed ceramic  
 CC Mixed ceramic, coated  
 CN Si3N4 Ceramic  
 CR Al2O3 cutting ceramic, reinforced

**D**

Technical Information

**E**

Index



Tool holder

CRDNN



A298

**A**

Turning

**B**

Milling

**C**

Drilling

**D**

Technical  
Information

**E**

Index

System code > A198

Grade selection > A42

Technical info > A501

Cutting data > A366



**A**

Turning

- Ideal machining conditions
- ⊗ Normal machining conditions
- ⊗ Unfavourable machining conditions

SNGA	L	I.C	S	d
12 04	12.7	12.7	4.76	5.16

## Turning ceramic inserts

SN** negative insert					CM	CC	CN	CR
	<b>P</b>	<span style="color: blue;">●</span>						
	<b>M</b>							
	<b>K</b>	<span style="color: red;">⊗</span>						
	<b>N</b>							
	<b>S</b>						<span style="color: orange;">●</span>	<span style="color: orange;">⊗</span>
	<b>H</b>					<span style="color: blue;">○</span>		
ISO	r	a <sub>p</sub>	f					
				CA1000		CM1000	CN1000 CS1000	CW1400 CW1800
	<b>SNGA120404T02020</b>	0.4	0.1-1.0	0.1-0.2			<span style="color: blue;">○</span>	
	<b>SNGA120408S02020</b>	0.8	0.1-0.4	0.1-0.3		<span style="color: blue;">○</span>		
	<b>SNGA120408T02020</b>	0.8	0.1-0.4	0.1-0.3	<span style="color: blue;">○</span>	<span style="color: blue;">○</span>	<span style="color: blue;">○</span>	
	<b>SNGA120412T02020</b>	1.2	0.2-2.0	0.1-0.3			<span style="color: blue;">○</span>	

● Ex stock    ○ On demand

CM Mixed ceramic  
 CC Mixed ceramic, coated  
 CN Si3N4 Ceramic  
 CR Al2O3 cutting ceramic, reinforced

**B**

Milling

**C**

Drilling

**D**

Technical Information

**E**

Index

Tool holder						
DSBNR/L	PSBNR/L	PSDNN	PSKNR/L	PSSNR/L	MSBNR/L	MSRNR/L
Kr: 75°	Kr: 75°	Kr: 45°	Kr: 75°	Kr: 45°	Kr: 75°	Kr: 75°
A232	A242	A244	A245	A246	A256	A257
MSKNR/L	MSDNN	S***-PSKNR/L				
Kr: 75°	Kr: 45°	Kr: 75°				
A258	A259	A329				

System code > A198

Grade selection > A42

Technical info > A501

Cutting data > A366

SNGN	L	I.C	S
12 04	12.7	12.7	4.76
12 07	12.7	12.7	7.94
15 07	15.875	15.875	7.94
19 07	19.05	19.05	7.94

- Ideal machining conditions
- Normal machining conditions
- Unfavourable machining conditions

**Turning ceramic inserts**

SN** negative insert				CM	CC	CN	CR
	<b>P</b>	●					
	<b>M</b>						
	<b>K</b>	●			●		
	<b>N</b>						
	<b>S</b>					●	●
	<b>H</b>				○		
ISO	r	a <sub>p</sub>	f	CA1000	CM1000	CN1000 CS1000	CW1400 CW1800
<b>SNGN120404T02020</b>	0.4	0.1-0.3	0.08-0.25	○			
<b>SNGN120408S01520</b>	0.8	0.1-0.25	0.5-2.5				○
<b>SNGN120408S02020</b>	0.8	0.1-0.4	0.1-0.3		○		
<b>SNGN120408T00520</b>	0.8	0.15-1.5	0.1-0.25			○	●
<b>SNGN120408T02020</b>	0.8	0.1-0.4	0.1-0.3	○		●	
<b>SNGN120412S01520</b>	1.2	0.1-0.3	0.5-2.5				○
<b>SNGN120412T00520</b>	1.2	0.1-0.3	0.5-2.5				●
<b>SNGN120412T02020</b>	1.2	0.1-0.5	0.1-0.3	○		○	
<b>SNGN120416S01520</b>	1.6	0.1-0.35	0.5-3.0				○
<b>SNGN120416T00520</b>	1.6	0.1-0.35	0.5-3.0				○
<b>SNGN120416T02020</b>	1.6	0.1-0.6	0.1-0.4	○		○	
<b>SNGN120704T02020</b>	0.4	0.1-0.3	0.08-0.25	●			
<b>SNGN120708S01520</b>	0.8	0.1-0.25	0.5-2.5				○
<b>SNGN120708T00520</b>	0.8	0.1-0.25	0.5-2.5				●
<b>SNGN120708T02020</b>	0.8	0.1-0.4	0.1-0.3	○	○	○	
<b>SNGN120712S01520</b>	1.2	0.1-0.3	0.5-2.5				○
<b>SNGN120712T00520</b>	1.2	0.1-0.3	0.5-2.5				●
<b>SNGN120712T02020</b>	1.2	0.1-0.5	0.1-0.3	○	○	●	
<b>SNGN120716S01520</b>	1.6	0.1-0.35	0.5-3.0				○
<b>SNGN120716T00520</b>	1.6	0.1-0.35	0.5-3.0				○
<b>SNGN120716T01520</b>	1.6	0.1-0.35	0.5-3.0				○
<b>SNGN120716T02020</b>	1.6	0.1-0.6	0.1-0.4	○			
<b>SNGN150708T02020</b>	0.8	0.1-0.4	0.1-0.3	○			
<b>SNGN150712T02020</b>	1.2	0.1-0.5	0.1-0.3	●		○	
<b>SNGN150716T02020</b>	1.6	0.1-0.6	0.1-0.4	●		○	
<b>SNGN190716S02030</b>	1.6	0.5-2.0	0.1-0.35			○	
<b>SNGN190716T03020</b>	1.6	0.1-0.6	0.1-0.4	○			

● Ex stock ○ On demand

CM Mixed ceramic  
 CC Mixed ceramic, coated  
 CN Si3N4 Ceramic  
 CR Al2O3 cutting ceramic, reinforced

**A**

Turning

**B**

Milling

**C**

Drilling

**D**

Technical Information

**E**

Index



**A**

Turning

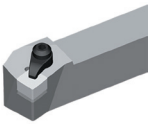
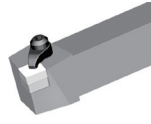
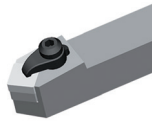
Tool holder		
CSKNR/L	CSRNR/L	CSDNN
Kr: 75°	Kr: 75°	Kr: 45°
		
A296	A297	A299

**B**

Milling

**C**

Drilling

**D**

Technical Information

**E**

Index

System code > A198

Grade selection > A42

Technical info > A501

Cutting data > A366

- Ideal machining conditions
- ⊗ Normal machining conditions
- ⊗ Unfavourable machining conditions

SNGX	L	I.C	S
12 07	12.7	12.7	7.94

**Turning ceramic inserts**

SN** negative insert					CM	CC	CN	CR
	<b>P</b>	●						
	<b>M</b>	●						
	<b>K</b>	●				⊗		
	<b>N</b>	●						
	<b>S</b>	●					●	⊗ ⊗
	<b>H</b>	●				○		
ISO	r	a <sub>p</sub>	f	CA1000	CM1000	CN1000 CS1000	CW1400 CW1800	
<b>SNGX120712T02020</b>	1.2	0.2-2.0	0.1-0.3			○		
<b>SNGX120716T02020</b>	1.6	0.5-2.0	0.1-0.35			○		

● Ex stock   ○ On demand

CM Mixed ceramic  
 CC Mixed ceramic, coated  
 CN Si3N4 Ceramic  
 CR Al2O3 cutting ceramic, reinforced

Tool holder

**JSDNN**

Kr: 45°

A302

**A**

Turning

**B**

Milling

**C**

Drilling

**D**

Technical Information

**E**

Index



**A**

Turning

**B**

Milling

**C**

Drilling

**D**

Technical Information

**E**

Index

- Ideal machining conditions
- ⊗ Normal machining conditions
- ⊗ Unfavourable machining conditions

TNGA	L	I.C	S	d
16 04	16.5	9.525	4.76	3.86
22 04	22	12.7	4.76	5.16

## Turning ceramic inserts

TN** negative insert				CM	CC	CN	CR
	<b>P</b>	<span style="color: blue;">●</span>					
	<b>M</b>						
	<b>K</b>	<span style="color: red;">●</span>				<span style="color: red;">⊗</span>	
	<b>N</b>						
	<b>S</b>					<span style="color: orange;">●</span>	<span style="color: orange;">⊗</span>
	<b>H</b>				<span style="color: grey;">○</span>		
ISO	r	a <sub>p</sub>	f	CA1000	CM1000	CN1000 CS1000	CW1400 CW1800
<b>TNGA160404S02020</b>	0.4	0.1-0.3	0.08-0.25		<span style="color: black;">●</span>		
<b>TNGA160404T01020</b>	0.4	0.1-0.3	0.08-0.25		<span style="color: grey;">○</span>	<span style="color: black;">●</span>	
<b>TNGA160404T02020</b>	0.4	0.1-0.3	0.08-0.25		<span style="color: grey;">○</span>		
<b>TNGA160408S02020</b>	0.8	0.1-0.4	0.1-0.3		<span style="color: black;">●</span>		
<b>TNGA160408T02020</b>	0.8	0.1-0.4	0.1-0.3		<span style="color: grey;">○</span>	<span style="color: black;">●</span>	
<b>TNGA160412T02020</b>	1.2	0.1-0.5	0.1-0.3		<span style="color: grey;">○</span>	<span style="color: black;">●</span>	
<b>TNGA220408T02020</b>	0.8	0.15-1.5	0.1-0.25			<span style="color: grey;">○</span>	
<b>TNGA220412T02020</b>	1.2	0.2-2.0	0.1-0.3			<span style="color: grey;">○</span>	
<b>TNGA220416T02020</b>	1.6	0.5-2.0	0.1-0.35			<span style="color: grey;">○</span>	

● Ex stock    ○ On demand

CM Mixed ceramic  
 CC Mixed ceramic, coated  
 CN Si3N4 Ceramic  
 CR Al2O3 cutting ceramic, reinforced

Tool holder						
DTGNR/L	PTFNR/L	PTTNR/L	PTGNR/L	MTGNR/L	MTJNR/L	MTJNR/L-Z
Kr: 91°	Kr: 91°	Kr: 60°	Kr: 90°	Kr: 90°	Kr: 93°	Kr: 93°
A233	A247	A248	A249	A260	A261	A262
MTFNR/L	S***-PTFNR/L					
Kr: 91°	Kr: 90°					
A263	A330					



TNGN	L	I.C	S
16 04	16.5	9.525	4.76
16 07	16.5	9.525	7.94
22 04	22	12.7	4.76

- Ideal machining conditions
- ⊗ Normal machining conditions
- ⊗ Unfavourable machining conditions

**Turning ceramic inserts**

TN** negative insert				CM	CC	CN	CR
	<b>P</b>	<span style="color: blue;">●</span>					
	<b>M</b>						
	<b>K</b>	<span style="color: red;">●</span>			<span style="color: red;">⊗</span>		
	<b>N</b>						
	<b>S</b>					<span style="color: orange;">●</span>	<span style="color: orange;">⊗</span> <span style="color: orange;">⊗</span>
	<b>H</b>				<span style="color: blue;">○</span>		
ISO	r	a <sub>p</sub>	f	CA1000	CM1000	CN1000 CS1000	CW1400 CW1800
	<b>TNGN160404T02020</b>	0.4	0.1-0.3	0.08-0.25	<span style="color: blue;">○</span>		
	<b>TNGN160408S02020</b>	0.8	0.1-0.4	0.1-0.3		<span style="color: blue;">○</span>	
	<b>TNGN160408T02020</b>	0.8	0.1-0.4	0.1-0.3	<span style="color: blue;">○</span>		<span style="color: blue;">○</span>
	<b>TNGN160412T02020</b>	1.2	0.1-0.5	0.1-0.3	<span style="color: blue;">○</span>		<span style="color: blue;">○</span>
	<b>TNGN160416T02020</b>	1.6	0.5-2.0	0.1-0.35	<span style="color: blue;">○</span>		<span style="color: blue;">○</span>
	<b>TNGN160708T02020</b>	0.8	0.15-1.5	0.1-0.25	<span style="color: blue;">○</span>		<span style="color: blue;">○</span>
	<b>TNGN160712T02020</b>	1.2	0.1-0.5	0.1-0.3	<span style="color: blue;">○</span>		<span style="color: blue;">○</span>
	<b>TNGN220408T02020</b>	0.8	0.1-0.4	0.1-0.3	<span style="color: blue;">○</span>		<span style="color: blue;">○</span>
	<b>TNGN220412T02020</b>	1.2	0.1-0.5	0.1-0.3	<span style="color: blue;">○</span>		<span style="color: blue;">○</span>
	<b>TNGN220416T02020</b>	1.6	0.1-0.6	0.1-0.4	<span style="color: blue;">○</span>		<span style="color: blue;">○</span>

● Ex stock    ○ On demand

CM Mixed ceramic  
 CC Mixed ceramic, coated  
 CN Si3N4 Ceramic  
 CR Al2O3 cutting ceramic, reinforced

Tool holder	
<b>CTJNR/L</b>	<b>CTUNR/L</b>
Kr: 93°	Kr: 93°
A293	A295



**A**

Turning

- Ideal machining conditions
- ⊗ Normal machining conditions
- ⊗ Unfavourable machining conditions

VNGA	L	I.C	S	d
16 07	16.6	9.525	7.94	3.81
16 04	16.6	9.525	4.76	3.81

## Turning ceramic inserts

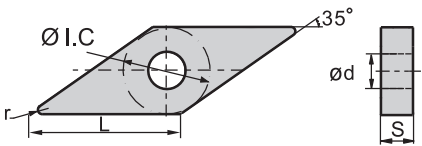
VN** negative insert		CM	CC	CN	CR
	<b>P</b>	●			
	<b>M</b>				
	<b>K</b>	●		⊗	
	<b>N</b>				
	<b>S</b>			●	⊗
	<b>H</b>		○		

**B**

Milling



ISO	r	a <sub>p</sub>	f	CA1000		CM1000		CN1000 CS1000		CW1400 CW1800	
				●	○	●	○	●	○		
<b>VNGA160404S02020</b>	0.4	0.1-0.3	0.08-0.25			●					
<b>VNGA160404T01020</b>	0.4	0.1-0.3	0.08-0.25			○					
<b>VNGA160408S02020</b>	0.4	0.1-0.4	0.1-0.3			●					
<b>VNGA160408T01020</b>	0.8	0.1-0.4	0.1-0.3			○					
<b>VNGA160408T02020</b>	0.8	0.1-0.4	0.1-0.3			●					
<b>VNGA160708S02020</b>	0.8	0.1-0.4	0.1-0.3			●					

● Ex stock    ○ On demand

CM Mixed ceramic  
 CC Mixed ceramic, coated  
 CN Si3N4 Ceramic  
 CR Al2O3 cutting ceramic, reinforced

**C**

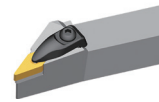
Drilling

Tool holder			
DVVNN	DVJNR/L	MVVNN	MVJNR/L
Kr: 72°30'	Kr: 93°	Kr: 72°30'	Kr: 93°
			
A234	A235	A264	A265

**D**

Technical Information

**E**

Index

System code > A198

Grade selection > A42

Technical info > A501

Cutting data > A366

- Ideal machining conditions
- ⊗ Normal machining conditions
- ⊗ Unfavourable machining conditions

WNGA	L	I.C	S	d
08 04	8.69	12.7	4.76	5.16

**Turning ceramic inserts**

WN** negative insert					CM	CC	CN	CR
	<b>P</b>	●						
	<b>M</b>							
	<b>K</b>	●				⊗		
	<b>N</b>							
	<b>S</b>						●	⊗
	<b>H</b>					○		
ISO	r	a <sub>p</sub>	f	CA1000	CM1000	CN1000 CS1000	CW1400 CW1800	
	<b>WNGA080404T01020</b>	0.4	0.1-0.3	0.08-0.25		○		
	<b>WNGA080404T02020</b>	0.4	0.1-0.3	0.08-0.25		○		
	<b>WNGA080408S02020</b>	0.8	0.1-0.4	0.1-0.3		○		
	<b>WNGA080408T02020</b>	0.8	0.1-0.4	0.1-0.3		○	●	
	<b>WNGA080412S02020</b>	1.2	0.1-0.5	0.1-0.3		○		
	<b>WNGA080412T02020</b>	1.2	0.1-0.5	0.1-0.3		○	●	
	<b>WNGA080416T01525</b>	1.6	0.5-2.0	0.1-0.35			○	
	<b>WNGA080416T02020</b>	1.6	0.5-2.0	0.1-0.35			●	

● Ex stock ○ On demand

CM Mixed ceramic  
 CC Mixed ceramic, coated  
 CN Si3N4 Ceramic  
 CR Al2O3 cutting ceramic, reinforced

Tool holder			
DWLNR/L	PWLNR/L	MWLNR/L	S***-PWLNR/L
Kr: 95°	Kr: 95°	Kr: 95°	Kr: 95°
A236	A251	A266	A332

System code > A198

Grade selection > A42

Technical info > A501

Cutting data > A366



A

Turning

B

Milling

C

Drilling

D

Technical Information

E

Index

**A**

Turning

**B**

Milling

**C**

Drilling

**D**

Technical Information

**E**

Index

RCGX	I.C	S	d
06 07	6	7.94	
06 04	6	4.76	
06 06	6	6.35	
09 07	9	7.94	
12 07	12	7.94	
19 10	19	10	

- Ideal machining conditions
- ⊗ Normal machining conditions
- ⊗ Unfavourable machining conditions

## Turning ceramic inserts

RC** positive insert				CM	CC	CN	CR
	<b>P</b>	<span style="color: blue;">●</span>					
	<b>M</b>						
	<b>K</b>	<span style="color: red;">●</span>			<span style="color: red;">⊗</span>		
	<b>N</b>	<span style="color: green;">●</span>					
	<b>S</b>	<span style="color: orange;">●</span>			<span style="color: orange;">●</span>	<span style="color: orange;">⊗</span> <span style="color: orange;">⊗</span>	
	<b>H</b>			<span style="color: grey;">○</span>			
ISO	a <sub>p</sub>	f	CA1000	CM1000	CN1000 CS1000	CW1400 CW1800	
<b>RCGX060400S01520</b>	0.1-0.25	0.5-2.5				<span style="color: grey;">○</span>	
<b>RCGX060400T00520</b>	0.1-0.25	0.5-2.5				<span style="color: grey;">○</span>	
<b>RCGX060600S02020</b>	0.1-0.3	0.08-0.25	<span style="color: grey;">○</span>				
<b>RCGX060600T01020</b>	0.1-0.25	0.5-2.5				<span style="color: grey;">○</span>	
<b>RCGX060700T00525</b>	0.1-0.25	0.5-2.5			<span style="color: grey;">○</span>	<span style="color: grey;">○</span> <span style="color: grey;">○</span>	
<b>RCGX090700S01520</b>	0.1-0.3	0.5-2.5				<span style="color: grey;">○</span>	
<b>RCGX090700T00520</b>	0.1-0.3	0.5-2.5				<span style="color: grey;">○</span>	
<b>RCGX090700T00525</b>	0.1-0.3	0.5-2.5			<span style="color: grey;">○</span>	<span style="color: grey;">○</span> <span style="color: grey;">○</span>	
<b>RCGX090700T20015</b>	0.1-0.3	0.1-0.3	<span style="color: grey;">○</span>				
<b>RCGX120700E</b>	0.5-2.0	0.1-0.2			<span style="color: grey;">○</span>		
<b>RCGX120700S01020</b>	0.5-2.0	0.1-0.2			<span style="color: grey;">○</span>		
<b>RCGX120700S01520</b>	0.1-0.35	0.5-3.0				<span style="color: grey;">○</span>	
<b>RCGX120700T00520</b>	0.1-0.35	0.5-3.0				<span style="color: grey;">○</span>	
<b>RCGX120700T00525</b>	0.1-0.35	0.5-3.0			<span style="color: grey;">○</span>	<span style="color: grey;">○</span> <span style="color: grey;">○</span>	
<b>RCGX120700T01020</b>	0.1-0.35	0.5-3.0		<span style="color: grey;">○</span>		<span style="color: grey;">○</span>	
<b>RCGX191000T02020</b>	0.1-0.6	0.1-0.5		<span style="color: grey;">○</span>			

● Ex stock    ○ On demand

CM Mixed ceramic  
 CC Mixed ceramic, coated  
 CN Si3N4 Ceramic  
 CR Al2O3 cutting ceramic, reinforced

RPGN	I.C	S
12 04	12.7	4.76

- Ideal machining conditions
- ⊗ Normal machining conditions
- ⊗ Unfavourable machining conditions

**Turning ceramic inserts**

RP** positive insert			CM	CC	CN	CR
	<b>P</b>	●				
	<b>M</b>	●				
	<b>K</b>	●			⊗	
	<b>N</b>					
	<b>S</b>				●	⊗ ⊗
	<b>H</b>			○		
ISO	a <sub>p</sub>	f	CA1000	CM1000	CN1000 CS1000	CW1400 CW1800
	<b>RPGN120400S01520</b>	0.1-0.35	0.5-3.0			○
	<b>RPGN120400T00520</b>	0.1-0.35	0.5-3.0			○

● Ex stock   ○ On demand

CM Mixed ceramic  
 CC Mixed ceramic, coated  
 CN Si3N4 Ceramic  
 CR Al2O3 cutting ceramic, reinforced

**A**

Turning

**B**

Milling

**C**

Drilling

**D**

Technical Information

**E**

Index

System code > A198

Grade selection > A42

Technical info > A501

Cutting data > A366



**A**

Turning

- Ideal machining conditions
- ⊗ Normal machining conditions
- ⊗ Unfavourable machining conditions

RPGX	I.C	S
09 07	9.525	7.94

## Turning ceramic inserts

RP** positive insert				CM	CC	CN	CR
	<b>P</b>	<span style="color: blue;">●</span>					
	<b>M</b>						
	<b>K</b>	<span style="color: red;">●</span>			<span style="color: red;">⊗</span>		
	<b>N</b>						
	<b>S</b>				<span style="color: orange;">●</span>	<span style="color: orange;">⊗</span>	<span style="color: orange;">⊗</span>
	<b>H</b>			<span style="color: grey;">○</span>			
ISO	a <sub>p</sub>	f	CA1000	CM1000	CN1000 CS1000	CW1400 CW1800	
<b>RPGX090700T00525</b>	0.1-0.3	0.5-2.5				<span style="color: grey;">○</span> <span style="color: grey;">○</span>	

● Ex stock    ○ On demand

CM Mixed ceramic  
 CC Mixed ceramic, coated  
 CN Si3N4 Ceramic  
 CR Al2O3 cutting ceramic, reinforced

**B**

Milling

**C**

Drilling

**D**

Technical Information

**E**

Index

System code > A198

Grade selection > A42

Technical info > A501

Cutting data > A366

- Ideal machining conditions
- ⊗ Normal machining conditions
- ⊗ Unfavourable machining conditions

TPGN	L	I.C	S
11 03	11	6.35	3.18
16 03	16.5	9.525	3.18

**Turning ceramic inserts**

TP** positive insert				CM	CC	CN	CR
	<b>P</b>	●					
	<b>M</b>						
	<b>K</b>	●			⊗		
	<b>N</b>						
	<b>S</b>					●	⊗ ⊗
	<b>H</b>				○		
ISO	r	a <sub>p</sub>	f	CA1000	CM1000	CN1000 CS1000	CW1400 CW1800
	<b>TPGN110304T02020</b>	0.4	0.1-0.3	0.08-0.25		○	
	<b>TPGN160304T01020</b>	0.4	0.1-0.3	0.08-0.25		○	
	<b>TPGN160308T01020</b>	0.8	0.1-0.4	0.1-0.3		○	

● Ex stock   ○ On demand

CM Mixed ceramic  
 CC Mixed ceramic, coated  
 CN Si3N4 Ceramic  
 CR Al2O3 cutting ceramic, reinforced

**A**

Turning

**B**

Milling

**C**

Drilling

**D**











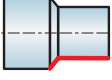

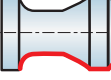
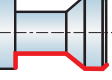



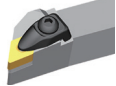











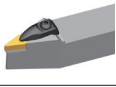

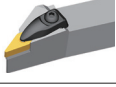



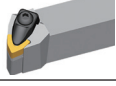



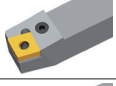

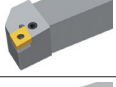







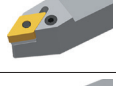

Technical Information

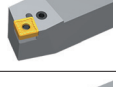
**E**

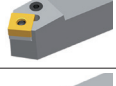
Index











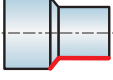

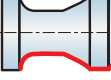
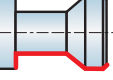



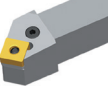

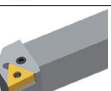
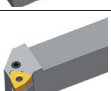
### External turning tool holders

Tool holder	Application					Workpiece		Page
	External machining	Facing	Profiling	Profiling	Profiling	Stable	Unstable	
<b>A</b> Turning DCLNR/L 95° 								A230
<b>B</b> Milling DDJNR/L 93° 								A231
<b>D</b> Milling DSBNR/L 75° 								A232
<b>D</b> Milling DTGNR/L 91° 								A233
<b>D</b> Milling DVVNN 72.5° 								A234
<b>C</b> Drilling DVJNR/L 93° 								A235
<b>D</b> Drilling DWLNR/L 95° 								A236
<b>P</b> Milling PCBNR/L 75° 								A237
<b>D</b> Milling PCLNR/L 95° 								A238
<b>P</b> Milling PDJNR/L 93° 								A240
<b>P</b> Milling PDNNR/L 63° 								A241
<b>P</b> Milling PSBNR/L 75° 								A242
<b>E</b> Index PSDNN 45° 								A244
<b>E</b> Index PSKNR/L 75° 								A245

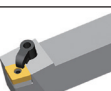
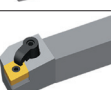
 Recommended

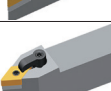
## External turning tool holders

Tool holder	Application					Workpiece		Page	
	External machining	Facing	Profiling	Profiling	Profiling	Stable	Unstable		
									
<b>P</b>	PSSNR/L 45° 	<input checked="" type="checkbox"/>	<input checked="" type="checkbox"/>				<input checked="" type="checkbox"/>	<input type="checkbox"/>	A246
	PTFNR/L 91° 		<input checked="" type="checkbox"/>				<input checked="" type="checkbox"/>	<input type="checkbox"/>	A247
	PTTNR/L 60° 	<input checked="" type="checkbox"/>					<input checked="" type="checkbox"/>	<input type="checkbox"/>	A248
	PTGNR/L 90° 	<input checked="" type="checkbox"/>					<input checked="" type="checkbox"/>	<input type="checkbox"/>	A249
	PWLNRL/L 95° 	<input checked="" type="checkbox"/>	<input checked="" type="checkbox"/>				<input checked="" type="checkbox"/>	<input type="checkbox"/>	A251
	PLANR/L 90° 	<input checked="" type="checkbox"/>	<input checked="" type="checkbox"/>			<input checked="" type="checkbox"/>	<input checked="" type="checkbox"/>	<input type="checkbox"/>	A316
	PLFNR/L 90° 	<input checked="" type="checkbox"/>					<input checked="" type="checkbox"/>	<input type="checkbox"/>	A317
	PCLNR/L 95° 	<input checked="" type="checkbox"/>	<input checked="" type="checkbox"/>				<input checked="" type="checkbox"/>	<input type="checkbox"/>	A318
<b>M</b>	MCBNR/L 75° 	<input checked="" type="checkbox"/>					<input checked="" type="checkbox"/>	<input type="checkbox"/>	A252
	MCLNR/L 95° 	<input checked="" type="checkbox"/>	<input checked="" type="checkbox"/>				<input checked="" type="checkbox"/>	<input type="checkbox"/>	A253
	MDJNR/L 93° 			<input checked="" type="checkbox"/>	<input checked="" type="checkbox"/>	<input checked="" type="checkbox"/>	<input checked="" type="checkbox"/>	<input checked="" type="checkbox"/>	A254
	MDPNN 62.5° 					<input checked="" type="checkbox"/>	<input checked="" type="checkbox"/>	<input type="checkbox"/>	A255
	MSBNR/L 75° 	<input checked="" type="checkbox"/>					<input checked="" type="checkbox"/>	<input type="checkbox"/>	A256
	MSRNR/L 75° 	<input checked="" type="checkbox"/>					<input checked="" type="checkbox"/>	<input type="checkbox"/>	A257

 Recommended

**A**

Turning

**B**

Milling

**C**

Drilling

**D**













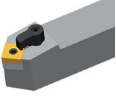

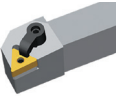

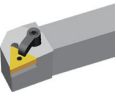

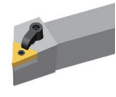













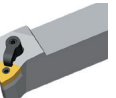



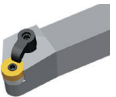

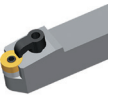

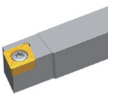

Technical Information

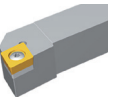
**E**

Index

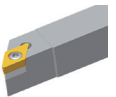

## External turning tool holders

Tool holder	Application					Workpiece		Page
	External machining	Facing	Profiling	Profiling	Profiling	Stable	Unstable	
<b>M</b>	MSKNR/L 75° 							A258
	MSDNN 45° 							A259
	MTGNR/L 90° 							A260
	MTJNR/L 93° 							A261
	MTJNR/L-Z 93° 							A262
	MTFNR/L 91° 							A263
	MVVNN 72,5° 							A264
	MVJNR/L 93° 							A265
	MWLNRL 95° 							A266
	MRGNR/L - 							A268
	MRDNN - 							A267
<b>S</b>	SCACR/L 90° 							A269
	SCLCR/L 95° 							A270
	SDACR/L 90° 							A271

 Recommended

**A**

Turning

**B**

Milling

**C**

Drilling





**D**

Technical Information

**E**

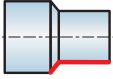
Index

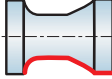
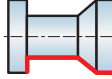
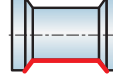
## External turning tool holders

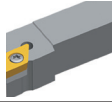
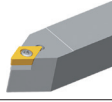
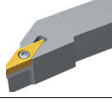
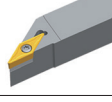
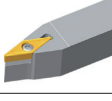
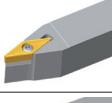
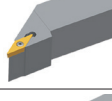
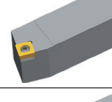
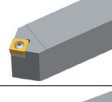
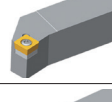
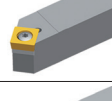
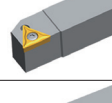
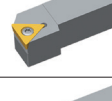
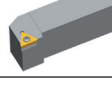
Tool holder	Application					Workpiece		Page
	External machining	Facing	Profiling	Profiling	Profiling	Stable	Unstable	
								
<b>SDJCR/L</b> 93° 	<input checked="" type="checkbox"/>			<input checked="" type="checkbox"/>		<input checked="" type="checkbox"/>	<input checked="" type="checkbox"/>	A272
<b>SDNCN</b> 63° 					<input checked="" type="checkbox"/>	<input checked="" type="checkbox"/>	<input checked="" type="checkbox"/>	A273
<b>SVJBR/L</b> 93° 	<input checked="" type="checkbox"/>			<input checked="" type="checkbox"/>		<input checked="" type="checkbox"/>	<input checked="" type="checkbox"/>	A274
<b>SVABR/L</b> 90° 	<input checked="" type="checkbox"/>			<input checked="" type="checkbox"/>		<input checked="" type="checkbox"/>	<input checked="" type="checkbox"/>	A275
<b>SVVBN</b> 72,5° 					<input checked="" type="checkbox"/>	<input checked="" type="checkbox"/>	<input checked="" type="checkbox"/>	A276
<b>SVVCN</b> 72,5° 					<input checked="" type="checkbox"/>	<input checked="" type="checkbox"/>	<input checked="" type="checkbox"/>	A277
<b>SVJCR/L</b> 93° 	<input checked="" type="checkbox"/>			<input checked="" type="checkbox"/>		<input checked="" type="checkbox"/>	<input checked="" type="checkbox"/>	A278
<b>SSBCR/L</b> 75° 	<input checked="" type="checkbox"/>					<input checked="" type="checkbox"/>		A279
<b>SSDCN</b> 45° 					<input checked="" type="checkbox"/>	<input checked="" type="checkbox"/>		A280
<b>SSKCR/L</b> 75° 		<input checked="" type="checkbox"/>				<input checked="" type="checkbox"/>		A281
<b>SSSCR/L</b> 45° 	<input checked="" type="checkbox"/>					<input checked="" type="checkbox"/>		A282
<b>STACR/L</b> 90° 	<input checked="" type="checkbox"/>					<input checked="" type="checkbox"/>	<input checked="" type="checkbox"/>	A283
<b>STFCR/L</b> 91° 		<input checked="" type="checkbox"/>				<input checked="" type="checkbox"/>		A284
<b>STGCR/L</b> 91° 	<input checked="" type="checkbox"/>					<input checked="" type="checkbox"/>	<input checked="" type="checkbox"/>	A285

 Recommended

**A**

Turning

**B**

Milling

**C**

Drilling











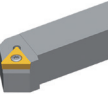
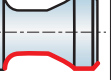
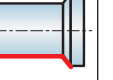



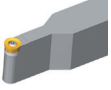

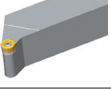

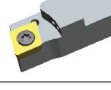















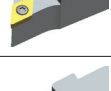





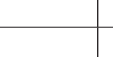
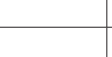
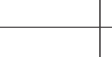



**D**

Technical Information

**E**

Index

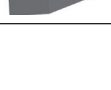
## External turning tool holders

Tool holder	Application					Workpiece		Page
	External machining	Facing	Profiling	Profiling	Profiling	Stable	Unstable	
<b>A</b> Turning STTCR/L 60° 								A286
<b>B</b> Milling SWACR/L 90° 								A287
SRDCN – 								A288
SRGCR/L – 								A289
<b>S</b> SCACR/L-SC 90° 								A306
SCLCR/L-SC 95° 								A307
SDACR/L-SC 90° 								A308
SDHCR/L-SC 107°30' 								A309
SDJCR/L-SC 93° 								A310
SDNCN-SC 62°30' 								A311
SVACR/L-SC 90° 								A312
SVJCR/L-SC 93° 								A313
<b>C</b> CKJNR/L 93° 								A290
CKNNR/L 63° 								A291

 Recommended



**P C L N L 25 25 M 12**

**1 2 3 4 5 6 7 8 9**

**A**

Turning

**B**

Milling

**C**

Drilling

**D**

Technical Information

**E**

Index

Clamping system			Insert shape	
Code	Description			
P	Lever lock clamping		C	
M	Wedge/pin lock clamping		D	
S	Screw-on clamping		R	
C/J	Wedge clamping		S	
D	Duel wedge clamping		T	
			V	
			W	

**1**



**2**

Tool holder type and entering angle				
<b>A</b>	<b>B</b>	<b>C</b>	<b>D</b>	<b>E</b>
<b>F</b>	<b>G</b>	<b>H</b>	<b>J</b>	<b>K</b>
<b>L</b>	<b>M</b>	<b>N</b>	<b>O</b>	<b>P</b>
<b>Q</b>	<b>R</b>	<b>S</b>	<b>T</b>	<b>U</b>
<b>V</b>	<b>W</b>	<b>X</b>		

**3**

Clearance angle	
<b>B</b>	<b>C</b>
<b>D</b>	<b>E</b>
<b>N</b>	<b>P</b>





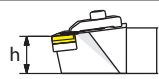

**4**

Cutting direction	
	
	
	
<b>5</b>	

Shank height h [mm]	
	
Code	h
12	12
16	16
20	20
25	25
32	32
40	40
50	50
<b>6</b>	

Shank width b [mm]	
	
Code	b
12	12
16	16
20	20
25	25
32	32
40	40
50	50
<b>7</b>	

Holder length L [mm]	
	
Code	L
H	100
K	125
M	150
P	170
Q	180
R	200
S	250
T	300
<b>8</b>	

Cutting edge length l [mm]								
I.C [mm]	Insert shape							
								
	C	D	R	S	T	V	W	
5,56	09							
6,35	06	07					11	
9,525	09	11	09	09	16	16	06	
12,7	12	15	12	12	22	22	08	
15,875	16	19	15	15	27			
19,05	19		19	19	33			
25,4	25		25	25	44			
32	32							
<b>9</b>								

**A**

Turning

**B**

Milling

**C**

Drilling

**D**

Technical Information

**E**

Index

A

## CN\*\* holder (external) D-Clamping

DCLNR/L Kr: 95°

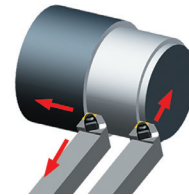
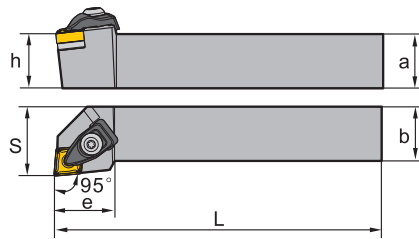
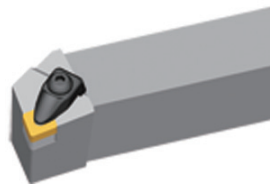

Turning

B







Article	*	Stock		Dimensions [mm]						Inserts
		R	L	a	b	L	h	s	e	
DCLNR/L1616H09	● ○	●	○	16	16	100	16	20	24	CN**0903**
DCLNR/L2020K09	● ●	●	●	20	20	125	20	25	24	CN**0903**
DCLNR/L2525M09	● ●	●	●	25	25	150	25	32	24	CN**0903**
DCLNR/L2020K12	● ●	●	●	20	20	125	20	25	28	CN**1204**
DCLNR/L2525M12	● ●	●	●	25	25	150	25	32	28	CN**1204**
DCLNR/L3225P12	● ●	●	●	32	25	170	32	32	28	CN**1204**

Milling

C

- Ex stock ○ On demand
- \* With internal cooling

Drilling

Spare parts			
	Insert	CN**0903**	CN**1204**
	h	16-25	20-32
	Clamp	C1RA	C2RA
	Screw (clamp)	CM5×22C (4.0 Nm)	CM6×25C (7.0 Nm)
	Screw (shim)	SM5×8.65XA1	SM6×10XA1
	Shim	C09BM	C12BM
	Spring	SPR6	SPR4
	Wrench (shim)	WH30L	WH40L
	Wrench (clamp)	WH30L	WH40L

D

Technical Information

Insert					
					
Wiper	Finishing	Medium Cut	Roughing	Cast Iron	PCBN/PCD
A51	A52	A53	A57	A61	A177

E

Index

System code > A228

Grade selection > A42

Technical info > A501

Cutting data > A366

**DN\*\* holder (external) D-Clamping**

DDJNR/L Kr: 93°

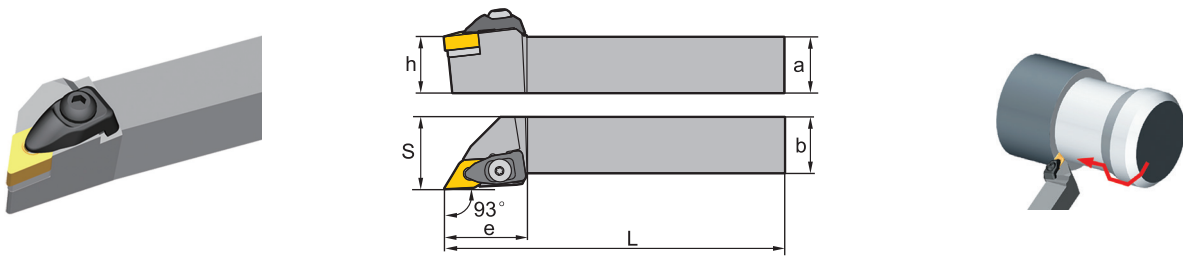







Article	*	Stock		Dimensions [mm]						Inserts
		R	L	a	b	L	h	s	e	
DDJNR/L1616H11	●	●	16	16	100	16	20	30	DN**1104**	
DDJNR/L2020K11	●	●	20	20	125	20	25	30	DN**1104**	
DDJNR/L2525M11	●	●	25	25	150	25	32	30	DN**1104**	
DDJNR/L3225P11	○	○	32	25	170	32	32	30	DN**1104**	
DDJNR/L2020K15	●	●	20	20	125	20	25	35	DN**1506**	
DDJNR/L2525M15	●	●	25	25	150	25	32	35	DN**1506**	
DDJNR/L3232P15	●	●	32	32	170	32	40	35	DN**1506**	

● Ex stock ○ On demand

\* With internal cooling

Spare parts

	Insert	DN**1104**	DN**1506**
	h	16-32	20-32
	Clamp	C1RA	C2RA
	Screw (clamp)	CM5×22C (4.0 Nm)	CM6×25C (7.0 Nm)
	Screw (shim)	SM5×8.65XA1	SM6×10XA1
	Shim	D11BM	D15BM
	Spring	SPR6	SPR4
	Wrench (shim)	WH30L	WH40L
	Wrench (clamp)	WH30L	WH40L

Insert

					
Wiper A62	Finishing A63	Medium Cut A63	Roughing A68	Cast Iron A69	PCBN/PCD A178

System code > A228

Grade selection > A42

Technical info > A501

Cutting data > A366



## SN\*\* holder (external) D-Clamping



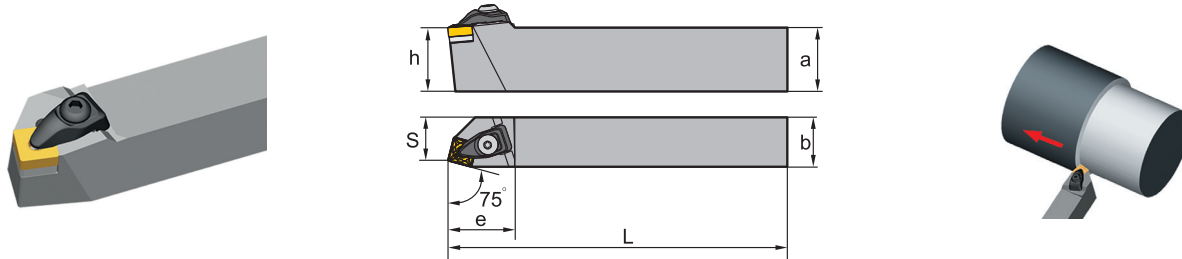



DSBNR/L Kr: 75°







Article	*	Stock		Dimensions [mm]						Inserts
		R	L	a	b	L	h	s	e	
DSBNR/L1616H09	○			16	16	100	16	13	26	SN**0903**
DSBNR/L2020K12	●	●		20	20	125	20	17	34	SN**1204**
DSBNR/L2525M12	●	●		25	25	150	25	22	34	SN**1204**
DSBNR/L3225P12	●	●		32	25	170	32	22	34	SN**1204**
DSBNR/L3232P15	●	●		32	32	170	32	27	41	SN**1506**

● Ex stock   ○ On demand

\* With internal cooling

Spare parts				
	Insert	SN**0903**	SN**1204**	SN**1506**
	h	16	20-32	32
	Clamp	C1RA	C2RA	C3RA
	Screw (clamp)	CM5×22C (4.0 Nm)	CM6×25C (7.0 Nm)	CM6×25C (7.0 Nm)
	Screw (shim)	SM5×8.65XA1	SM6×10XA1	SM6×10XA2
	Shim	S09BM	S12BM	S15BM
	Spring	SPR6	SPR4	SPR4
	Wrench (shim)	WH30L	WH40L	WH40L
	Wrench (clamp)	WH30L	WH40L	WH40L

Insert				
				
<b>Finishing</b>	<b>Medium Cut</b>	<b>Roughing</b>	<b>Cast Iron</b>	<b>PCBN/PCD</b>
A73	A73	A78	A84	A162

System code > A228

Grade selection > A42

Technical info > A501

Cutting data > A366

**TN\*\* holder (external) D-Clamping**

DTGNR/L Kr: 91°

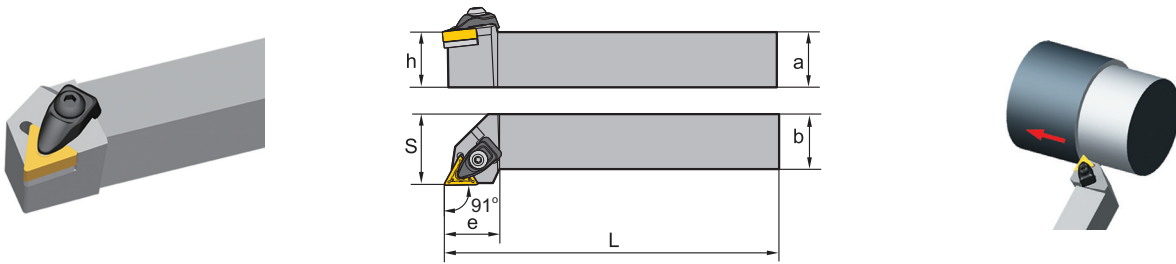







Article	*	Stock		Dimensions [mm]						Inserts
		R	L	a	b	L	h	s	e	
DTGNR/L1616H16		●	●	16	16	100	16	20	25	TN**1604**
DTGNR/L2020K16		●	●	20	20	125	20	25	25	TN**1604**
DTGNR/L2525M16		●	●	25	25	150	25	32	25	TN**1604**





● Ex stock ○ On demand

\* With internal cooling

Spare parts

	Insert h	TN**1604** 16-25
	Clamp	C1RA
	Screw (clamp)	CM5×22C (4.0 Nm)
	Screw (shim)	SM5×8.65XA1
	Shim	T16BM
	Spring	SPR6
	Wrench (shim)	WH30L
	Wrench (clamp)	WH30L

Insert

					
<b>Wiper</b> A87	<b>Finishing</b> A88	<b>Medium Cut</b> A90	<b>Roughing</b> A92	<b>Cast Iron</b> A99	<b>PCBN/PCD</b> A163

System code > A228

Grade selection > A42

Technical info > A501

Cutting data > A366

**A**

## VN\*\* holder (external) D-Clamping

DVVNN Kr: 72°30'

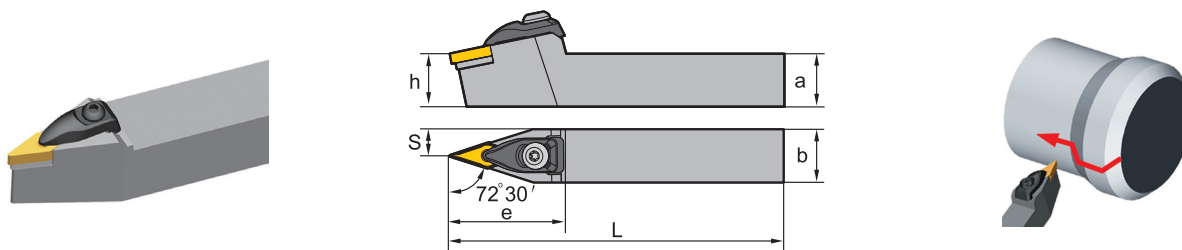

Turning

**B**

Article	*	Stock	Dimensions [mm]						Inserts
			a	b	L	h	s	e	
DVVNN2020K16	●		20	20	125	20	10	44	VN**1604**
DVVNN2525M16	●		25	25	150	25	12.5	44	VN**1604**

Milling

● Ex stock    ○ On demand

\* With internal cooling

**C**

Spare parts		
	Insert	VN**1604**
	h	20-25
	Clamp	C6RA
	Screw (clamp)	CM5×22C (4.0 Nm)
	Screw (shim)	SM5×8.65XA1
	Shim	V16BM
	Spring	SPR6
	Wrench (shim)	WH30L
	Wrench (clamp)	WH30L

Drilling

**D**

Insert				
<b>Finishing</b>	<b>Medium Cut</b>	<b>Roughing</b>	<b>Cast Iron</b>	<b>PCBN/PCD</b>
A102	A102	A104	A103	A179

Technical Information

**E**

Index

System code > A228

Grade selection > A42

Technical info > A501

Cutting data > A366

**VN\*\* holder (external) D-Clamping**

DVJNR/L Kr: 93°

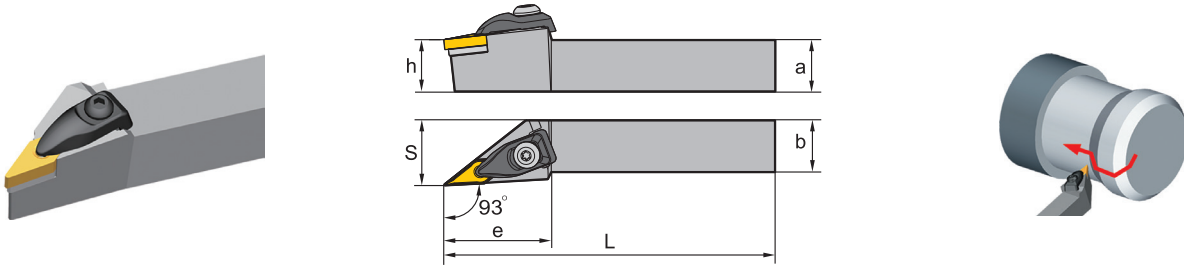







Article	*	Stock		Dimensions [mm]						Inserts
		R	L	a	b	L	h	s	e	
DVJNR/L2020K16	•	•		20	20	125	20	25	41	VN**1604**
DVJNR/L2525M16	•	•		25	25	150	25	32	41	VN**1604**

• Ex stock    ○ On demand

\* With internal cooling

Spare parts

	Insert h	VN**1604** 20-25
	Clamp	C6RA
	Screw (clamp)	CM5×22C (4.0 Nm)
	Screw (shim)	SM5×8.65XA1
	Shim	V16BM
	Spring	SPR6
	Wrench (clamp)	WH30L
	Wrench (shim)	WH30L

Insert

				
<b>Finishing</b> A102	<b>Medium Cut</b> A102	<b>Roughing</b> A104	<b>Cast Iron</b> A103	<b>PCBN/PCD</b> A179

System code > A228

Grade selection > A42

Technical info > A501

Cutting data > A366

A

Turning

B

Milling

C

Drilling

D

Technical  
Information

E

Index

**A**

## WN\*\* holder (external) D-Clamping

DWLNLR/L Kr: 95°

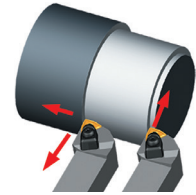
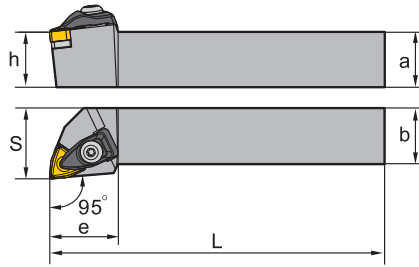
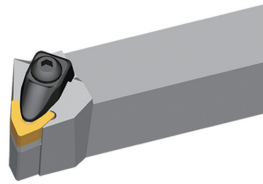

Turning

**B**

Article	*	Stock		Dimensions [mm]						Inserts
		R	L	a	b	L	h	s	e	
DWLNLR/L1616H06	●	●		16	16	100	16	25	24	WN**0604**
DWLNLR/L2020K06	●	●		20	20	125	20	25	24	WN**0604**
DWLNLR/L2525M06	●	●		25	25	150	25	32	24	WN**0604**
DWLNLR/L2020K08	●	●		20	20	125	20	25	31	WN**0804**
DWLNLR/L2525M08	●	●		25	25	150	25	32	31	WN**0804**
DWLNLR/L3225P08	●	●		32	25	170	32	32	31	WN**0804**

Milling

**C**

● Ex stock ○ On demand

\* With internal cooling

Drilling

Spare parts			
	Insert	WN**0604**	WN**0804**
		h	16-25
	Clamp	C1RA	C2RA
	Screw (clamp)	CM5×22C (4.0 Nm)	CM6×25C (7.0 Nm)
	Screw (shim)	SM5×8.65XA1	SM6×10XA1
	Shim	W06BM	W08BM
	Spring	SPR6	SPR4
	Wrench (shim)	WH30L	WH40L
	Wrench (clamp)	WH30L	WH40L

**D**

Technical Information

Insert					
Wiper	Finishing	Medium Cut	Roughing	Cast Iron	PCBN/PCD
A106	A107	A107	A109	A111	A165

**E**

Index

System code > A228

Grade selection > A42

Technical info > A501

Cutting data > A366

**CN\*\* holder (external) P-Clamping**

PCBNR/L Kr: 75°

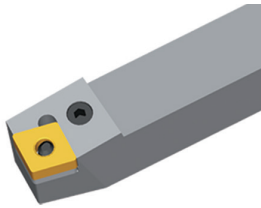



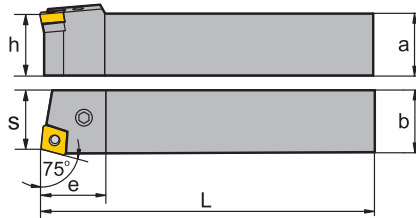



Right hand style









Article	*	Stock		Dimensions [mm]						Inserts
		R	L	a	b	L	h	s	e	
PCBNR/L2020K12		●	●	20	20	125	20	17	27	CN**1204**
PCBNR/L2525M12		●	●	25	25	150	25	22	27	CN**1204**
PCBNR/L3232P12		●	●	32	32	170	32	27	27	CN**1204**
PCBNR/L2525M16		●	●	25	25	150	25	22	33	CN**1606**
PCBNR/L3232P16		●	●	32	32	170	32	27	33	CN**1606**
PCBNR/L3232P19		●	●	32	32	170	32	27	38	CN**1906**
PCBNR/L4040S19		●	●	40	40	250	40	35	38	CN**1906**
PCBNR/L4040S2507		●	●	40	40	250	40	35	50	CN**2507**
PCBNR/L4040S2509		●	●	40	40	250	40	35	50	CN**2509**

● Ex stock ○ On demand

\* With internal cooling

Spare parts						
	Insert	CN**1204**	CN**1606**	CN**1906**	CN**2507**	CN**2509**
	h	20-32	25-32	32-40	40	40
	Knee lever	L4	L5	L6	L8	L8
	Screw	LEM8×21 (10.2 Nm)	LEM8×25 (10.2 Nm)	LEM10×27 (16.6 Nm)		
	Screw				LEM12×36A (25.2 Nm)	LEM12×36A (25.2 Nm)
	Shim	C12AP	C16AP	C19AP	C25AP-07	C25AP
	Shim pin (shim)	SP4	SP5	SP6	SP8	SP8
	Wrench	WH30L	WH30L	WH40L	WH50L	WH50L

Insert					
					
<b>Wiper</b>	<b>Finishing</b>	<b>Medium Cut</b>	<b>Roughing</b>	<b>Cast Iron</b>	<b>PCBN/PCD</b>
A51	A52	A53	A57	A61	A177

## CN\*\* holder (external) P-Clamping

PCLNR/L Kr: 95°

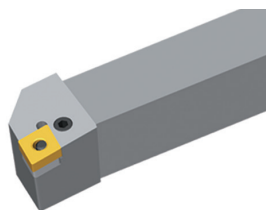

Right hand style

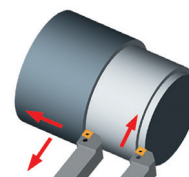
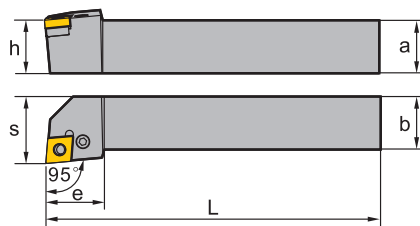

Article	*	Stock		Dimensions [mm]						Inserts
		R	L	a	b	L	h	s	e	
PCLNR/L1616H09	● ●	16	16	100	16	20	20	CN**0903**		
PCLNR/L2020K09	● ●	20	20	125	20	25	22	CN**0903**		
PCLNR/L2525M09	○ ●	25	25	150	25	32	22	CN**0903**		
PCLNR/L1616H12	○ ○	16	16	100	16	20	20	CN**1204**		
PCLNR/L2020K12	● ●	20	20	125	20	25	28	CN**1204**		
PCLNR/L2525M12	● ●	25	25	150	25	32	28	CN**1204**		
PCLNR/L3232P12	● ●	32	32	170	32	40	28	CN**1204**		
PCLNR/L2525M16	● ●	25	25	150	25	32	33	CN**1606**		
PCLNR/L3232P16	● ●	32	32	170	32	40	33	CN**1606**		
PCLNR/L3232P19	● ●	32	32	170	32	40	38	CN**1906**		
PCLNR/L4040S19	● ●	40	40	250	40	50	38	CN**1906**		
PCLNR/L4040S2507	● ●	40	40	250	40	50	49	CN**2507**		
PCLNR/L4040S2509	● ●	40	40	250	40	50	49	CN**2509**		







● Ex stock ○ On demand

\* With internal cooling

### Spare parts

	Insert	CN**0903**	CN**1204**	CN**1606**	CN**1906**	CN**2507**	CN**2509**
	h	16-25	16-32	25-32	32-40	40	40
	Knee lever	L3	L4	L5	L6	L8	L8
	Screw		LEM8×21 (10.2 Nm)	LEM8×25 (10.2 Nm)	LEM10×27 (16.6 Nm)		
	Screw	LEM6×13.4A (7.0 Nm)				LEM12×36A (25.2 Nm)	LEM12×36A (25.2 Nm)
	Shim	C09AP	C12AP	C16AP	C19AP	C25AP-07	C25AP
	Shim pin (shim)	SP10	SP4	SP5	SP6	SP8	SP8
	Wrench	WH25L	WH30L	WH30L	WH40L	WH50L	WH50L

**CN\*\* holder (external)**

Insert					
					
<b>Wiper</b>	<b>Finishing</b>	<b>Medium Cut</b>	<b>Roughing</b>	<b>Cast Iron</b>	<b>PCBN/PCD</b>
A51	A52	A53	A57	A61	A177

**A**

Turning

**B**

Milling

**C**

Drilling

**D**

Technical Information

**E**

Index

System code > A228

Grade selection > A42

Technical info > A501

Cutting data > A366



## DN\*\* holder (external) P-Clamping

PDJNR/L Kr: 93°

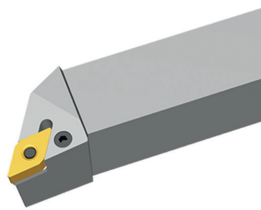

Right hand style

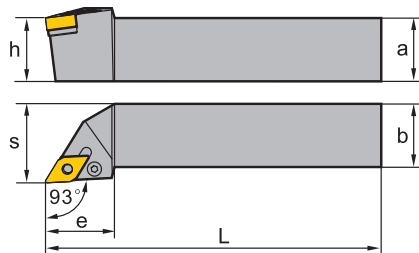

Article	*	Stock		Dimensions [mm]						Inserts
		R	L	a	b	L	h	s	e	
PDJNR/L1616H11	●	●		16	16	100	16	20	25	DN**1104**
PDJNR/L2020K11	●	●		20	20	125	20	25	25	DN**1104**
PDJNR/L2525M11	●	●		25	25	150	25	32	30	DN**1104**
PDJNR/L2020K15-3	●	○		20	20	125	20	25	35	DN**1504**
PDJNR/L2525M15-3	●	●		25	25	150	25	32	35	DN**1504**
PDJNR/L3232P15-3	●	●		32	32	170	32	40	35	DN**1504**
PDJNR/L2020K15	●	○		20	20	125	20	25	35	DN**1506**
PDJNR/L2525M15	●	●		25	25	150	25	32	35	DN**1506**
PDJNR/L3232P15	●	●		32	32	170	32	40	35	DN**1506**

● Ex stock ○ On demand

\* With internal cooling

### Spare parts

	Insert	DN**1104**	DN**1504**	DN**1506**
	h	16-32	20-32	20-32
	Knee lever	L3	L4	L4B
	Screw		LEM8×21 (10.2 Nm)	LEM8×21 (10.2 Nm)
	Screw	LEM6×13.4A (7.0 Nm)		
	Shim	D11AP	D15AP	D15AP
	Shim pin (shim)	SP3	SP4	SP4
	Wrench	WH25L	WH30L	WH30L

### Insert

Wiper	Finishing	Medium Cut	Roughing	Cast Iron	PCBN/PCD
A62	A63	A63	A68	A69	A178

System code > A228

Grade selection > A42

Technical info > A501

Cutting data > A366

**DN\*\* holder (external)** P-Clamping

PDNNR/L Kr: 63°

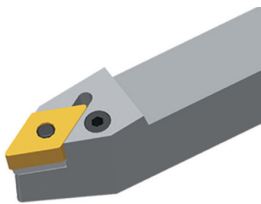



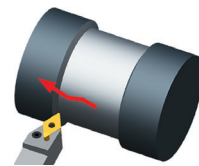
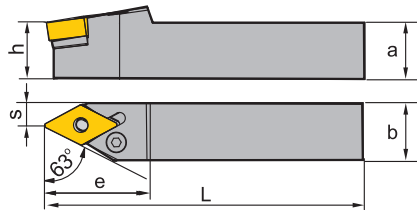

Left hand style









Article	*	Stock		Dimensions [mm]						Inserts
		R	L	a	b	L	h	s	e	
PDNNR/L2020K15-3	●	○		20	20	125	20	8	37	DN**1504**
PDNNR/L2525M15-3	●	○		25	25	150	25	12.5	37	DN**1504**
PDNNR/L3232P15-3	●	●		32	32	170	32	16	37	DN**1504**
PDNNR/L2020K15	●	●		20	20	125	20	8	37	DN**1506**
PDNNR/L2525M15	●	●		25	25	150	25	12.5	37	DN**1506**
PDNNR/L3232P15	●	●		32	32	170	32	16	37	DN**1506**

● Ex stock ○ On demand

\* With internal cooling

Spare parts			
	Insert	DN**1504**	DN**1506**
	hh	20-32	20-32
	Knee lever	L4	L4B
	Screw	LEM8×21 (10.2 Nm)	LEM8×21 (10.2 Nm)
	Shim	D15AP	D15AP
	Shim pin (shim)	SP4	SP4
	Wrench	WH30L	WH30L

Insert					
					
Wiper	Finishing	Medium Cut	Roughing	Cast Iron	PCBN/PCD
A62	A63	A63	A68	A69	A178

A

Turning

B

Milling

C

Drilling

D

Technical Information

E

Index

## SN\*\* holder (external) P-Clamping

PSBNR/L Kr: 75°

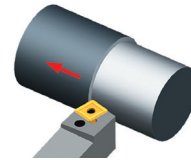
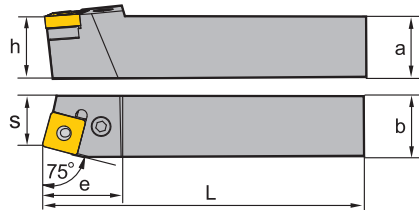
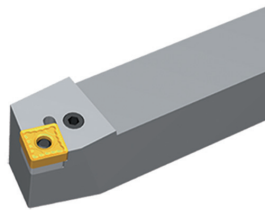

Right hand style

Article	*	Stock		Dimensions [mm]						Inserts
		R	L	a	b	L	h	s	e	
PSBNR/L1616H09	● ○	●	○	16	16	100	16	13	21	SN**0903**
PSBNR/L2020K09	● ○	●	○	20	20	125	20	17	23	SN**0903**
PSBNR/L2020K12	● ●	●	●	20	20	125	20	17	28	SN**1204**
PSBNR/L2525M12	● ●	●	●	25	25	125	25	22	28	SN**1204**
PSBNR/L3225P12	● ○	●	○	32	25	170	32	22	28	SN**1204**
PSBNR/L3232P12	● ○	●	○	32	32	170	32	27	28	SN**1204**
PSBNR/L2525M15	● ○	●	○	25	25	150	25	22	35	SN**1506**
PSBNR/L3232P15	● ●	●	●	32	32	170	32	27	35	SN**1506**
PSBNR/L3232P19	● ●	●	●	32	32	170	32	27	40	SN**1906**
PSBNR/L4040S19	● ●	●	●	40	40	250	40	35	40	SN**1906**
PSBNR/L4040S2507	○ ○	○	○	40	40	250	40	35	48	SN**2507**
PSBNR/L4040S2509	○ ○	○	○	40	40	250	40	35	48	SN**2509**





● Ex stock ○ On demand

\* With internal cooling

### Spare parts

	Insert	SN**0903**	SN**1204**	SN**1506**	SN**1906**	SN**2507**	SN**2509**
		h	16-20	20-32	25-32	32-40	40
	Knee lever	L3	L4	L5	L6	L8	L8
	Screw		LEM8×21 (10.2 Nm)	LEM8×25 (10.2 Nm)	LEM10×27 (16.6 Nm)		
	Screw	LEM6×13.4A (7.0 Nm)				LEM12×36A (25.2 Nm)	LEM12×36A (25.2 Nm)
	Shim	S09AP	S12AP	S15AP	S19AP	S25AP	
	Shim						S25AP-09
	Shim pin (shim)	SP10	SP4	SP5	SP6	SP8	SP8
	Wrench	WH25L	WH30L	WH30L	WH40L	WH50L	WH50L

**SN\*\* holder (external)**

Insert				
				
<b>Finishing</b>	<b>Medium Cut</b>	<b>Roughing</b>	<b>Cast Iron</b>	<b>PCBN/PCD</b>
A73	A73	A78	A84	A162

**A**

Turning

**B**

Milling

**C**

Drilling

**D**

Technical Information

**E**

Index

System code > A228

Grade selection > A42

Technical info > A501

Cutting data > A366

## SN\*\* holder (external) P-Clamping

PSDNN Kr: 45°

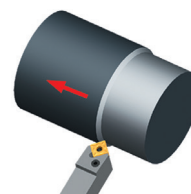
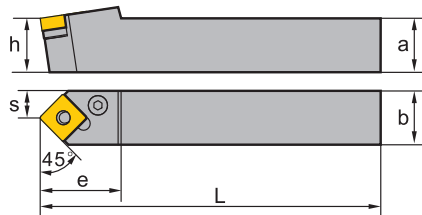
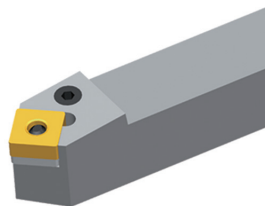

Article	*	Stock	Dimensions [mm]						Inserts
			a	b	L	h	s	e	
PSDNN1212F09		○	12	12	80	12	6	21	SN**0903**
PSDNN1616H09		●	16	16	100	16	8	23	SN**0903**
PSDNN2020K12		●	20	20	125	20	10	30	SN**1204**
PSDNN2525M12		●	20	20	150	20	12.5	30	SN**1204**
PSDNN3232P12		●	32	32	170	32	16	40	SN**1204**
PSDNN2525M15		●	25	25	150	25	12.5	40	SN**1506**
PSDNN3232P15		●	32	32	170	32	16	40	SN**1506**
PSDNN3232P19		●	32	32	170	32	16	40	SN**1906**
PSDNN4040S19		●	40	40	250	40	20	40	SN**1906**

● Ex stock ○ On demand

\* With internal cooling

Spare parts						
	Insert	SN**0903**	SN**0903**	SN**1204**	SN**1506**	SN**1906**
	h	12	16	20-32	25-32	32-40
	Knee lever	L3B	L3	L3	L5	L6
	Screw	LEM5×12B (4.0 Nm)				
	Screw				LEM8×25 (10.2 Nm)	LEM10×27 (16.6 Nm)
	Screw		LEM6×13.4A (7.0 Nm)	LEM6×13.4A (7.0 Nm)		
	Shim		S09AP	S12AP	S15AP	S19AP
	Shim pin (shim)		SP10	SP10	SP5	SP6
	Wrench		WH25L	WH25L	WH30L	WH40L
	Wrench	WT09IP				

Insert				
<b>Finishing</b>	<b>Medium Cut</b>	<b>Roughing</b>	<b>Cast Iron</b>	<b>PCBN/PCD</b>
A73	A73	A78	A84	A162

System code > A228

Grade selection > A42

Technical info > A501

Cutting data > A366

**SN\*\* holder (external) P-Clamping**

PSKNR/L Kr: 75°

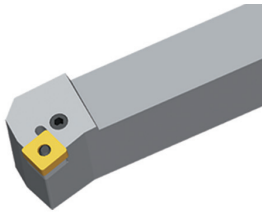



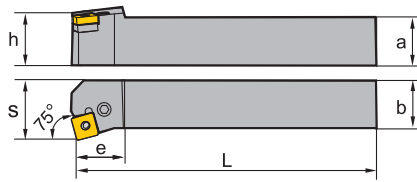



Right hand style







Article	*	Stock		Dimensions [mm]						Inserts
		R	L	a	b	L	h	s	e	
PSKNR/L1616H09		○	○	16	16	100	16	20	17	SN**0903**
PSKNR/L2020K09		●	○	20	20	125	20	25	20	SN**0903**
PSKNR/L2020K12		●	●	20	20	125	20	25	26	SN**1204**
PSKNR/L2525M12		●	●	25	25	150	25	32	26	SN**1204**
PSKNR/L3232P12		●	●	32	32	170	32	40	26	SN**1204**
PSKNR/L2525M15		●	○	25	25	150	25	32	32	SN**1506**
PSKNR/L3232P15		●	●	32	32	170	32	40	32	SN**1506**
PSKNR/L3232P19		●	●	32	32	170	32	40	36	SN**1906**
PSKNR/L4040S19		○	○	40	40	250	40	50	40	SN**1906**

● Ex stock ○ On demand

\* With internal cooling

Spare parts		SN**0903**	SN**1204**	SN**1506**	SN**1906**
		16-20	20-32	25-32	32-40
	Knee lever	L3	L4	L5	L6
	Screw		LEM8×21 (10.2 Nm)	LEM8×25 (10.2 Nm)	LEM10×27 (16.6 Nm)
	Screw	LEM6×13.4A (7.0 Nm)			
	Shim	S09AP	S12AP	S15AP	S19AP
	Shim pin (shim)	SP10	SP4	SP5	SP6
	Wrench	WH25L	WH30L	WH30L	WH40L

Insert				
				
Finishing	Medium Cut	Roughing	Cast Iron	PCBN/PCD
A73	A73	A78	A84	A162

## SN\*\* holder (external) P-Clamping

PSSNR/L Kr: 45°

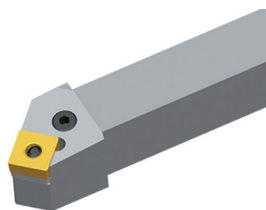

Right hand style

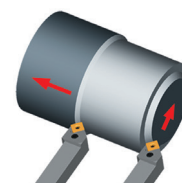
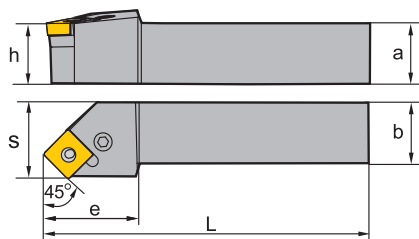

Article	*	Stock		Dimensions [mm]						Inserts
		R	L	a	b	L	h	s	e	
PSSNR/L1616H09	●	●		16	16	100	16	20	25	SN**0903**
PSSNR/L2020K12	●	●		20	20	125	20	25	30	SN**1204**
PSSNR/L2525M12	●	●		25	25	150	25	32	30	SN**1204**
PSSNR/L3232P12	●	●		32	32	170	32	40	40	SN**1204**
PSSNR/L2525M15	●	●		25	25	150	25	32	30	SN**1506**
PSSNR/L3232P15	●	●		32	32	170	32	40	40	SN**1506**
PSSNR/L3232P19	●	●		32	32	170	32	40	40	SN**1906**
PSSNR/L4040S19	●	●		40	40	250	40	50	50	SN**1906**
PSSNR/L4040S2507	●	●		40	40	250	40	50	50	SN**2507**
PSSNR/L4040S2509	●	●		40	40	250	40	50	50	SN**2509**

● Ex stock ○ On demand

\* With internal cooling

Spare parts							
	Insert	SN**0903**	SN**1204**	SN**1506**	SN**1906**	SN**2507**	SN**2509**
	<b>h</b>	<b>16</b>	<b>20-32</b>	<b>25-32</b>	<b>32-40</b>	<b>40</b>	<b>40</b>
	Knee lever	L3	L4	L5	L6	L8	L8
	Screw		LEM8×21 (10.2 Nm)	LEM8×25 (10.2 Nm)	LEM10×27 (16.6 Nm)		
	Screw	LEM6×13.4A (7.0 Nm)				LEM12×36A (25.2 Nm)	LEM12×36A (25.2 Nm)
	Shim	S09AP	S12AP	S15AP	S19AP	S25AP	
	Shim						S25AP-09
	Shim pin (shim)	SP10	SP4	SP5	SP6	SP8	SP8
	Wrench	WH25L	WH30L	WH30L	WH40L	WH50L	WH50L

Insert				
<b>Finishing</b>	<b>Medium Cut</b>	<b>Roughing</b>	<b>Cast Iron</b>	<b>PCBN/PCD</b>
A73	A73	A78	A84	A162

System code > A228

Grade selection > A42

Technical info > A501

Cutting data > A366

**TN\*\* holder (external)** P-Clamping

PTFNR/L Kr: 91°

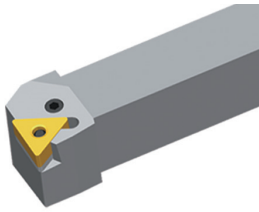

Right hand style

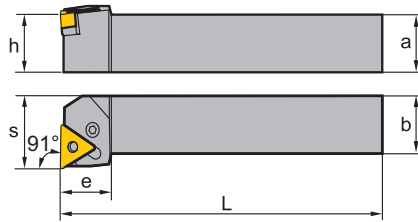

Article	*	Stock		Dimensions [mm]						Inserts
		R	L	a	b	L	h	s	e	
PTFNR/L1616H16	●	●	16	16	100	16	20	20	TN**1604**	
PTFNR/L2020K16	●	●	20	20	125	20	25	20	TN**1604**	
PTFNR/L2525M16	●	●	25	25	150	25	32	20	TN**1604**	
PTFNR/L2525M22	●	●	25	25	150	25	32	25	TN**2204**	
PTFNR/L3232P22	●	●	32	32	170	32	40	25	TN**2204**	
PTFNR/L3232P27	●	○	32	32	170	32	40	34	TN**2706**	
PTFNR/L4040S27	○	○	40	40	250	40	50	34	TN**2706**	

● Ex stock ○ On demand

\* With internal cooling

Spare parts				
	Insert	TN**1604**	TN**2204**	TN**2706**
	h	16-25	25-32	32-40
	Knee lever	L3	L4	L5
	Screw		LEM8×21 (10.2 Nm)	LEM8×25 (10.2 Nm)
	Screw	LEM6×13.4A (7.0 Nm)		
	Shim	T16AP	T22AP	T27AP
	Shim pin (shim)	SP3	SP4	SP5
	Wrench	WH25L	WH30L	WH30L

Insert						
Wiper A87	Finishing A88	Medium Cut A90	Roughing A92	Heavy Turning A97	Cast Iron A99	PCBN/PCD A163

A

Turning

B

Milling

C

Drilling

D

Technical Information

E

Index



**A**

Turning

## TN\*\* holder (external) P-Clamping

PTTNR/L Kr: 60°

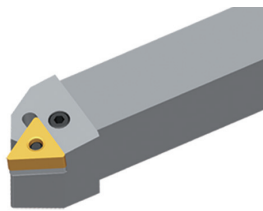

Right hand style

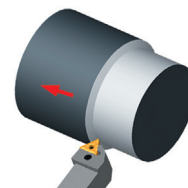
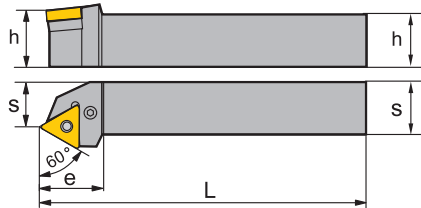

**B**

Milling

Article	*	Stock		Dimensions [mm]						Inserts
		R	L	a	b	L	h	s	e	
PTTNR/L1616H16	●			16	16	100	16	13	25	TN**1604**
PTTNR/L2020K16	●	○		20	20	125	20	17	25	TN**1604**
PTTNR/L2525M22	●	●		25	25	150	20	22	32	TN**2204**

● Ex stock ○ On demand

\* With internal cooling

**C**

Drilling

### Spare parts

	Insert	TN**1604**	TN**2204**
	h	16-25	20
	Knee lever	L3	L4
	Screw		LEM8×21 (10.2 Nm)
	Screw	LEM6×13.4A (7.0 Nm)	
	Shim	T16AP	T22AP
	Shim pin (shim)	SP3	SP4
	Wrench	WH25L	WH30L

**D**

Technical Information

### Insert

<b>Wiper</b> A87	<b>Finishing</b> A88	<b>Medium Cut</b> A90	<b>Roughing</b> A92	<b>Heavy Turning</b> A97	<b>Cast Iron</b> A99	<b>PCBN/PCD</b> A163

**E**

Index

System code > A228

Grade selection > A42

Technical info > A501

Cutting data > A366

**TN\*\* holder (external)** P-Clamping

PTGNR/L Kr: 90°

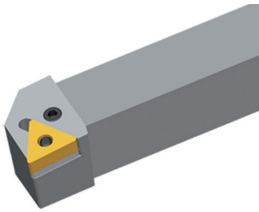

Right hand style

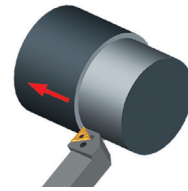
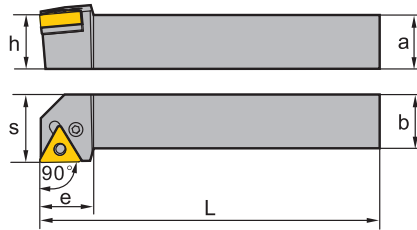









Article	*	Stock		Dimensions [mm]						Inserts
		R	L	a	b	L	h	s	e	
PTGNR/L1010E11	●			10	10	70	10	14	16	TN**1103**
PTGNR/L1212F11	●	●		12	12	80	12	16	14	TN**1103**
PTGNR/L1616H11	●			16	16	100	16	20	18	TN**1103**
PTGNR/L2020K11	●	○		20	20	125	20	25	19	TN**1103**
PTGNR/L2525M11	○	○		25	25	150	25	32	20	TN**1103**
PTGNR/L1616H16	●	●		16	16	100	16	20	20	TN**1604**
PTGNR/L2020K16	●	●		20	20	125	20	25	20	TN**1604**
PTGNR/L2525M16	●	●		25	25	150	25	32	20	TN**1604**
PTGNR/L3232P16	●	○		32	32	170	32	40	20	TN**1604**
PTGNR/L2525M22	●	●		25	25	150	25	32	28	TN**2204**
PTGNR/L3232P22	●	●		32	32	170	32	40	28	TN**2204**
PTGNR/L3232P27	●	○		32	32	170	32	40	33	TN**2706**
PTGNR/L4040S27	○	○		40	40	250	40	50	33	TN**2706**

● Ex stock ○ On demand

\* With internal cooling







Spare parts

	Insert h	TN**1103**	TN**1604**	TN**2204**	TN**2706**
		10-25	16-32	25-32	32-40
	Knee lever	L2	L3	L4	L5
	Screw	LEM5×9B (4.0 Nm)			
	Screw			LEM8×21 (10.2 Nm)	LEM8×25 (10.2 Nm)
	Screw		LEM6×13.4A (7.0 Nm)		
	Shim		T16AP	T22AP	T27AP
	Shim pin (shim)		SP3	SP4	SP5
	Wrench		WH25L	WH30L	WH30L
	Wrench	WT09IP			

**A**

Turning

## TN\*\* holder (external)

Insert						
						
<b>Wiper</b>	<b>Finishing</b>	<b>Medium Cut</b>	<b>Roughing</b>	<b>Heavy Turning</b>	<b>Cast Iron</b>	<b>PCBN/PCD</b>
A87	A88	A90	A92	A97	A99	A163

**B**

Milling

**C**

Drilling

**D**

Technical Information

**E**

Index

System code > A228

Grade selection > A42

Technical info > A501

Cutting data > A366

**WN\*\* holder (external) P-Clamping**

PWLNLR/L Kr: 95°

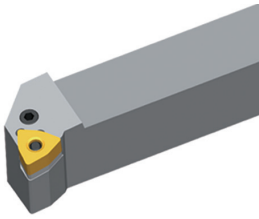

Right hand style

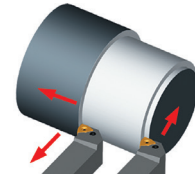
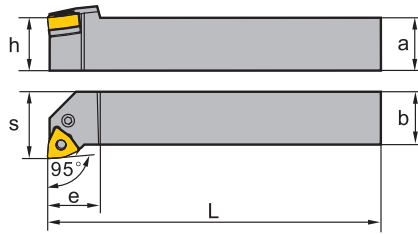

Article	*	Stock		Dimensions [mm]						Inserts
		R	L	a	b	L	h	s	e	
PWLNLR/L1616H06	●	●	16	16	100	16	20	20	WN**0604**	
PWLNLR/L2020K06	●	●	20	20	125	20	25	20	WN**0604**	
PWLNLR/L2525M06	●	●	25	25	150	25	32	20	WN**0604**	
PWLNLR/L2020K08	●	●	20	20	125	20	25	26	WN**0804**	
PWLNLR/L2525M08	●	●	25	25	150	25	32	26	WN**0804**	

● Ex stock ○ On demand

\* With internal cooling

Spare parts

	Insert h	WN**0604**	WN**0804**
		16-25	20-25
Knee lever		L3	L4
Screw			LEM8x21 (10.2 Nm)
Screw		LEM6x13.4A (7.0 Nm)	
Shim		W06AP	W08AP
Shim pin (shim)		SP3	SP4
Wrench		WH25L	WH30L

Insert

<b>Wiper</b> A106	<b>Finishing</b> A107	<b>Medium Cut</b> A107	<b>Roughing</b> A109	<b>Cast Iron</b> A111	<b>PCBN/PCD</b> A165

## CN\*\* holder (external) M-Clamping

MCBNR/L Kr: 75°

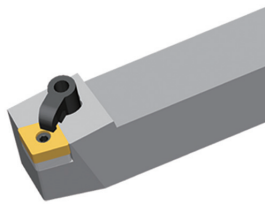

Right hand style

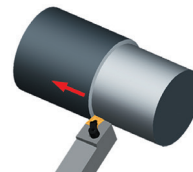
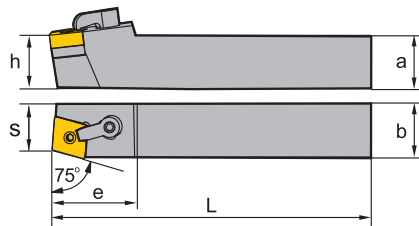

Article	*	Stock		Dimensions [mm]						Inserts
		R	L	a	b	L	h	s	e	
MCBNR/L2020K12	● ○	●	○	20	20	125	20	17	32	CN**1204**
MCBNR/L2525M12	● ●	●	●	25	25	150	20	22	32	CN**1204**
MCBNR/L3225P12	● ●	●	●	32	25	170	32	22	32	CN**1204**
MCBNR/L2525M16	○ ○	○	○	25	25	150	25	22	40	CN**1606**
MCBNR/L3232P16	● ●	●	●	32	32	170	32	27	40	CN**1606**
MCBNR/L3232P19	○ ○	○	○	32	32	170	32	27	45	CN**1906**
MCBNR/L4040R19	○ ●	○	●	40	40	200	40	35	45	CN**1906**

● Ex stock ○ On demand

\* With internal cooling

Spare parts		Insert	CN**1204**	CN**1204**	CN**1606**	CN**1906**
		h	20	25-32	25-32	32-40
	Clamp		C1RD	C1RD	C2RD	C5RD
	Dowel pin		TM6×17	TM6×17	TM8×21	TM10×21
	Screw (clamp)		DM6×25 (7.0 Nm)	DM6×30 (7.0 Nm)	DM6×30 (7.0 Nm)	
	Screw (clamp)					DM8×30X (10.2 Nm)
	Shim		C12BM	C12BM	C16BM	C19BM
	Wrench (dowel pin)		WH30L	WH30L	WH30L	WH40L
	Wrench (clamp)		WH30L	WH30L	WH30L	WH40L

Insert					
Wiper	Finishing	Medium Cut	Roughing	Cast Iron	PCBN/PCD
A51	A52	A53	A57	A61	A177

System code > A228

Grade selection > A42

Technical info > A501

Cutting data > A366

**CN\*\* holder (external)** **M-Clamping**

MCLNR/L Kr: 95°

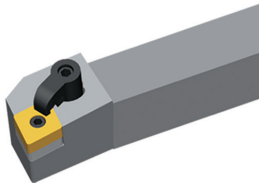



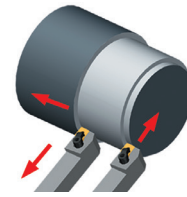
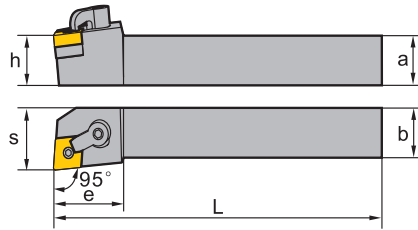





Right hand style









Article	*	Stock		Dimensions [mm]						Inserts
		R	L	a	b	L	h	s	e	
MCLNR/L2020K12	●	●	20	20	125	20	25	32	CN**1204**	
MCLNR/L2525M12	●	●	25	25	150	25	32	32	CN**1204**	
MCLNR/L3225P12	●	●	32	25	170	32	32	32	CN**1204**	
MCLNR/L2525M16	●	●	25	25	150	25	32	38	CN**1606**	
MCLNR/L3232P16	●	●	32	32	170	32	40	38	CN**1606**	
MCLNR/L3232P19	●	●	32	32	170	32	40	45	CN**1906**	
MCLNR/L4040R19	●	○	40	40	200	40	50	45	CN**1906**	
MCLNR/L4040S25	○	○	40	40	250	40	50	38	CN**2509**	

● Ex stock ○ On demand

\* With internal cooling

Spare parts						
	Insert	CN**1204**	CN**1204**	CN**1606**	CN**1906**	CN**2509**
	h	20	25-32	25-32	32-40	40
	Clamp	C1RD	C1RD	C2RD	C5RD	C6RD
	Dowel pin	TM6×17	TM6×17	TM8×21	TM10×21	TM12×29 (25.2 Nm)
	Screw (clamp)	DM6×25 (7.0 Nm)	DM6×30 (7.0 Nm)	DM6×30 (7.0 Nm)		
	Screw (clamp)				DM8×30X (10.2 Nm)	DM10×35X (16.6 Nm)
	Shim	C12BM	C12BM	C16BM	C19BM	
	Shim					C25BM-09
	Wrench (clamp)	WH30L	WH30L	WH30L	WH40L	WH50L
	Wrench (dowel pin)	WH30L	WH30L	WH30L	WH40L	WH40L

Insert					
					
Wiper	Finishing	Medium Cut	Roughing	Cast Iron	PCBN/PCD
A51	A52	A53	A57	A61	A177

A

Turning

B

Milling

C

Drilling

D

Technical Information

E

Index

## DN\*\* holder (external) M-Clamping

MDJNR/L Kr: 93°

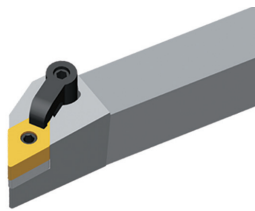

Right hand style

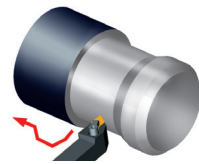
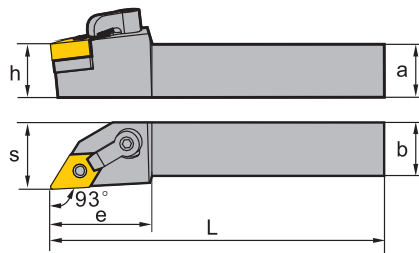

Article	*	Stock		Dimensions [mm]						Inserts
		R	L	a	b	L	h	s	e	
MDJNR/L2020K11	●	●		20	20	125	20	25	32	DN**1104**
MDJNR/L2525M11	●	●		25	25	150	25	32	32	DN**1104**
MDJNR/L3225P11	●	○		32	25	170	32	32	32	DN**1104**
MDJNR/L2020K15	●	●		20	20	125	20	25	38	DN**1506**
MDJNR/L2525M15	●	●		25	25	150	25	32	38	DN**1506**
MDJNR/L3225P15	●	●		32	25	170	32	32	38	DN**1506**

● Ex stock ○ On demand

\* With internal cooling

### Spare parts

	Insert h	DN**1104**	DN**1104**	DN**1506**	DN**1506**
		20	25-32	20	25-32
Clamp		C1RD	C1RD	C2RD	C2RD
Dowel pin		TM5×13	TM5×13	TM6×19	TM6×19
Screw (clamp)		DM6×25 (7.0 Nm)	DM6×30 (7.0 Nm)	DM6×25 (7.0 Nm)	DM6×30 (7.0 Nm)
Shim		D11BM	D11BM	D15BM	D15BM
Wrench (clamp)		WH30L	WH30L	WH30L	WH30L
Wrench (dowel pin)		WH20L	WH20L	WH30L	WH30L

### Insert

Wiper A62	Finishing A63	Medium Cut A63	Roughing A68	Cast Iron A69	PCBN/PCD A178

System code > A228

Grade selection > A42

Technical info > A501

Cutting data > A366

**DN\*\* holder (external) M-Clamping**

MDPNN Kr: 62°30'

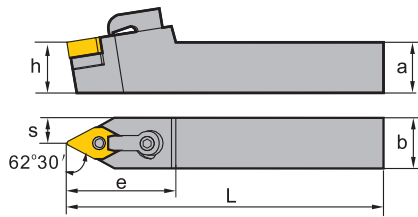
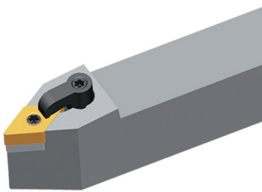

Article	*	Stock	Dimensions [mm]						Inserts
			a	b	L	h	s	e	
MDPNN2020K11	●		20	20	125	20	10	35	DN**1104**
MDPNN2525M11	●		25	25	150	25	12.5	35	DN**1104**
MDPNN2020K15	●		20	20	125	20	10	40	DN**1506**
MDPNN2525M15	●		25	25	150	25	12.5	40	DN**1506**
MDPNN3225P15	●		32	25	170	32	12.5	40	DN**1506**

● Ex stock ○ On demand

\* With internal cooling

Spare parts		DN**1104**	DN**1104**	DN**1506**	DN**1506**
Insert		20	25-32	20	25-32
h		20	25-32	20	25-32
	Clamp	C1RD	C1RD	C2RD	C2RD
	Dowel pin	TM5×13	TM5×13	TM6×19	TM6×19
	Screw (clamp)	DM6×25 (7.0 Nm)	DM6×30 (7.0 Nm)	DM6×25 (7.0 Nm)	DM6×30 (7.0 Nm)
	Shim	D11BM	D11BM	D15BM	D15BM
	Wrench (clamp)	WH30L	WH30L	WH30L	WH30L
	Wrench (dowel pin)	WH20L	WH20L	WH30L	WH30L

Insert					
Wiper	Finishing	Medium Cut	Roughing	Cast Iron	PCBN/PCD
A62	A63	A63	A68	A69	A178

System code > A228

Grade selection > A42

Technical info > A501

Cutting data > A366



A

Turning

B

Milling

C

Drilling

D

Technical Information

E

Index



## SN\*\* holder (external) M-Clamping

MSBNR/L Kr: 75°

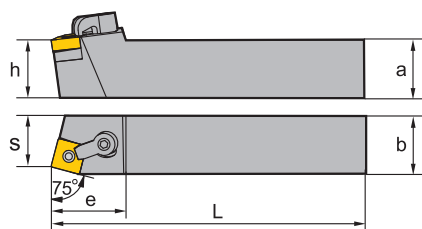
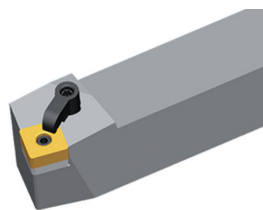

Right hand style

Article	*	Stock		Dimensions [mm]						Inserts
		R	L	a	b	L	h	s	e	
MSBNR/L2020K12	●	●		20	20	125	20	17	32	SN**1204**
MSBNR/L2525M12	●	○		25	25	150	25	22	32	SN**1204**
MSBNR/L3225P12		●		32	25	170	32	22	32	SN**1204**
MSBNR/L2525M15	●	○		25	25	150	25	22	38	SN**1506**
MSBNR/L3232P15	●	●		32	32	170	32	29	38	SN**1506**
MSBNR/L4032R15	○			40	32	200	40	27	38	SN**1506**
MSBNR/L3232P19	●	●		32	32	170	32	27	45	SN**1906**
MSBNR/L4040R19	○	●		40	40	200	40	35	45	SN**1906**
MSBNR/L4040R25	●	○		40	40	200	40	35	50	SN**2507**
MSBNR/L4040S2509	○	○		40	40	250	40	35	50	SN**2509**

● Ex stock ○ On demand

\* With internal cooling

### Spare parts

	Insert	SN**1204**	SN**1204**	SN**1506**	SN**1906**	SN**2507**	SN**2509**
	h	20	25-32	25-40	32-40	40	40
	Clamp	C1RD	C1RD	C2RD	C5RD	C6RD	C6RD
	Dowel pin	TM6×17	TM6×17	TM8×21	TM10×21	TM12×29	TM12×29
	Screw (clamp)	DM6×25 (7.0 Nm)	DM6×30 (7.0 Nm)	DM6×30 (7.0 Nm)			
	Screw (clamp)				DM8×30X (10.2 Nm)	DM10×35X (16.6 Nm)	DM10×35X (16.6 Nm)
	Shim	S12BM	S12BM	S15BM	S19BM	S25BM	S25BM
	Wrench (clamp)	WH30L	WH30L	WH30L	WH40L	WH40L	WH40L
	Wrench (dowel pin)	WH31L	WH31L	WH30L	WH40L	WH50L	WH50L

### Insert

<b>Finishing</b>	<b>Medium Cut</b>	<b>Roughing</b>	<b>Cast Iron</b>	<b>PCBN/PCD</b>
A73	A73	A78	A84	A162

System code > A228

Grade selection > A42

Technical info > A501

Cutting data > A366

**SN\*\* holder (external)** **M-Clamping**

MSRNR/L Kr: 75°

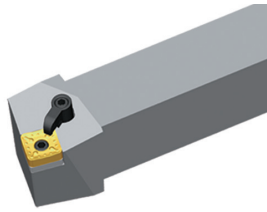

Right hand style

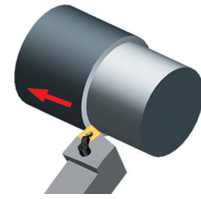
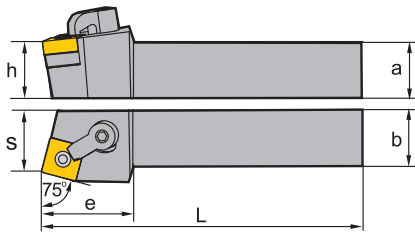

Article	*	Stock		Dimensions [mm]						Inserts
		R	L	a	b	L	h	s	e	
MSRNR/L2020K12	●	●		20	20	125	20	22	36	SN**1204**
MSRNR/L2525M12	●	●		25	25	150	25	27	36	SN**1204**
MSRNR/L3225P12		○		32	25	170	32	27	36	SN**1204**
MSRNR/L2525M15	●	○		25	25	150	25	27	40	SN**1506**
MSRNR/L3232P15	●	●		32	32	170	32	35	40	SN**1506**
MSRNR/L4032R15		○		40	32	200	40	35	40	SN**1506**
MSRNR/L3232P19		○	○	32	32	170	32	35	45	SN**1906**
MSRNR/L4040R19		○		40	40	200	40	43	45	SN**1906**
MSRNR/L4040R2509		○	○	40	40	200	40	43	50	SN**2509**
MSRNR/L4040S2509		○	○	40	40	250	40	43	50	SN**2509**

● Ex stock ○ On demand

\* With internal cooling

Spare parts		SN**1204**	SN**1204**	SN**1506**	SN**1906**	SN**2509**
Insert	h	20	25-32	25-40	32-40	40
	Clamp	C1RD	C1RD	C2RD	C5RD	C6RD
	Dowel pin	TM6×17	TM6×17	TM8×21	TM10×21	TM12×29
	Screw (clamp)	DM6×25 (7.0 Nm)	DM6×30 (7.0 Nm)	DM6×30 (7.0 Nm)		
	Screw (clamp)				DM8×30X (10.2 Nm)	DM10×35X (16.6 Nm)
	Shim	S12BM	S12BM	S15BM	S19BM	S25BM
	Wrench (clamp)	WH30L	WH30L	WH30L	WH40L	WH40L
	Wrench (dowel pin)	WH31L	WH31L	WH30L	WH40L	WH50L

Insert				
<b>Finishing</b>	<b>Medium Cut</b>	<b>Roughing</b>	<b>Cast Iron</b>	<b>PCBN/PCD</b>
A73	A73	A78	A84	A162

System code > A228

Grade selection > A42

Technical info > A501

Cutting data > A366



A

Turning

B

Milling

C

Drilling

D

Technical Information

E

Index

## SN\*\* holder (external) M-Clamping

MSKNR/L Kr: 75°

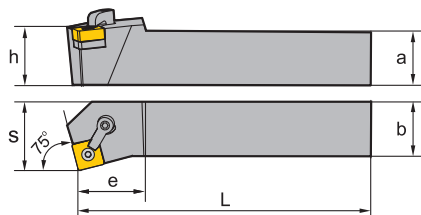
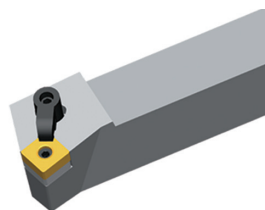

Right hand style

Article	*	Stock		Dimensions [mm]						Inserts
		R	L	a	b	L	h	s	e	
MSKNR/L2020K12	●	●		20	20	125	20	25	32	SN**1204**
MSKNR/L2525M12	●	●		25	25	150	25	32	32	SN**1204**
MSKNR/L3225P12	●	○		32	25	170	32	32	32	SN**1204**
MSKNR/L2525M15	●	○		25	25	150	25	32	28	SN**1506**
MSKNR/L3232P15	●	○		32	32	170	32	40	38	SN**1506**
MSKNR/L4032R15		○		40	32	200	40	40	38	SN**1506**
MSKNR/L3232P19	●	●		32	32	170	32	40	45	SN**1906**
MSKNR/L4040R19		○		40	40	200	40	50	45	SN**1906**
MSKNR/L4040S2509		○	●	40	40	250	40	50	50	SN**2509**

● Ex stock ○ On demand

\* With internal cooling

### Spare parts

	Insert	SN**1204**	SN**1204**	SN**1506**	SN**1906**	SN**2509**
	h	20	25-32	25-40	32-40	40
	Clamp	C1RD	C1RD	C2RD	C5RD	C6RD
	Dowel pin	TM6×17	TM6×17	TM8×21	TM10×21	TM12×29
	Screw (clamp)	DM6×25 (7.0 Nm)	DM6×30 (7.0 Nm)	DM6×30 (7.0 Nm)		
	Screw (clamp)				DM8×30X (10.2 Nm)	DM10×35X (16.6 Nm)
	Shim	S12BM	S12BM	S15BM	S19BM	S25BM
	Wrench (clamp)	WH30L	WH30L	WH30L	WH40L	WH40L
	Wrench (dowel pin)	WH30L	WH30L	WH30L	WH40L	WH50L

### Insert

Finishing	Medium Cut	Roughing	Cast Iron	PCBN/PCD
A73	A73	A78	A84	A162

System code > A228

Grade selection > A42

Technical info > A501

Cutting data > A366

SN\*\* holder (external) **M-Clamping**

MSDNN Kr: 45°

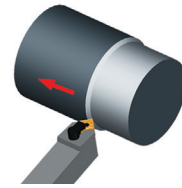
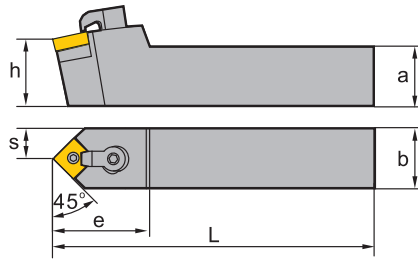
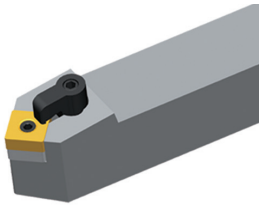

Article	*	Stock	Dimensions [mm]						Inserts
			a	b	L	h	s	e	
MSDNN2020K12	●	●	20	20	125	20	10	35	SN**1204**
MSDNN2525M12	●	●	25	25	150	25	12.5	35	SN**1204**
MSDNN3225P12	●	●	32	25	170	32	12.5	35	SN**1204**
MSDNN2525M15	●	●	25	25	150	25	12.5	42	SN**1506**
MSDNN3232P15	○	○	32	32	170	32	16	42	SN**1506**
MSDNN4032R15	○	○	40	32	200	40	16	42	SN**1506**

● Ex stock ○ On demand

\* With internal cooling

Spare parts				
	Insert	SN**1204**	SN**1204**	SN**1506**
	h	20	25-32	25-40
	Clamp	C1RD	C1RD	C2RD
	Dowel pin	TM6×17	TM6×17	TM8×21
	Screw (clamp)	DM6×25 (7.0 Nm)	DM6×30 (7.0 Nm)	DM6×30 (7.0 Nm)
	Shim	S12BM	S12BM	S15BM
	Wrench (clamp)	WH30L	WH30L	WH30L
	Wrench (dowel pin)	WH30L	WH30L	WH30L

Insert				
Finishing	Medium Cut	Roughing	Cast Iron	PCBN/PCD
A73	A73	A78	A84	A162

A

Turning

B

Milling

C

Drilling

D

Technical Information

E

Index

**A**

Turning

## TN\*\* holder (external) M-Clamping

MTGNR/L Kr: 90°

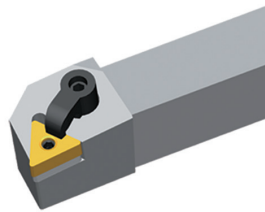

Right hand style

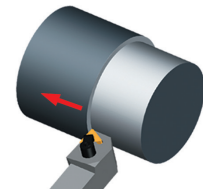
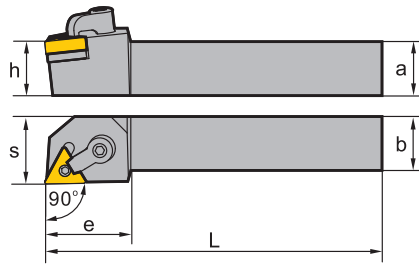

**B**

Milling

Article	*	Stock		Dimensions [mm]						Inserts
		R	L	a	b	L	h	s	e	
MTGNR/L2020K16	● ○	○	○	20	20	125	20	25	33	TN**1604**
MTGNR/L2525M16	● ●	●	●	25	25	150	25	32	33	TN**1604**
MTGNR/L3225P16	● ○	○	○	32	25	170	32	32	33	TN**1604**
MTGNR/L2525M22	● ○	○	○	25	25	150	25	32	35	TN**2204**
MTGNR/L3225P22	○ ○	○	○	32	25	170	32	32	35	TN**2204**

● Ex stock ○ On demand

\* With internal cooling

**C**

Drilling

Spare parts		TN**1604**	TN**1604**	TN**2204**
	Insert h	20	25-32	25-32
	Clamp	C1RD	C1RD	C2RD
	Dowel pin	TM5x13	TM5x13	TM6x17
	Screw (clamp)	DM6x25 (7.0 Nm)	DM6x30 (7.0 Nm)	DM6x30 (7.0 Nm)
	Shim	T16BM	T16BM	T22BM
	Wrench (clamp)	WH30L	WH30L	WH30L
	Wrench (dowel pin)	WH20L	WH20L	WH30L

**D**

Technical Information

Insert						
<b>Wiper</b>	<b>Finishing</b>	<b>Medium Cut</b>	<b>Roughing</b>	<b>Heavy Turning</b>	<b>Cast Iron</b>	<b>PCBN/PCD</b>
A87	A88	A90	A92	A97	A99	A163

**E**

Index

System code > A228

Grade selection > A42

Technical info > A501

Cutting data > A366

**TN\*\* holder (external)** M-Clamping

MTJNR/L Kr: 93°

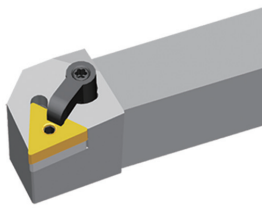

Right hand style

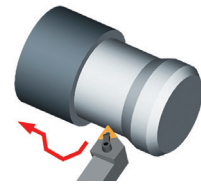
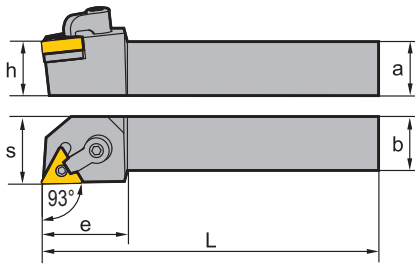

Article	*	Stock		Dimensions [mm]						Inserts
		R	L	a	b	L	h	s	e	
MTJNR/L2020K16	●			20	20	125	20	25	32	TN**1604**
MTJNR/L2525M16	○	○		25	25	150	25	32	32	TN**1604**
MTJNR/L3225P16	○			32	25	170	32	32	32	TN**1604**
MTJNR/L2525M22	○			25	25	150	25	32	36	TN**2204**
MTJNR/L3225P22	○	●		32	25	170	32	32	36	TN**2204**

● Ex stock ○ On demand

\* With internal cooling

Spare parts

	Insert h	TN**1604** 20	TN**1604** 25-32	TN**2204** 25-32
Clamp		C1RD	C1RD	C2RD
Dowel pin		TM5×13	TM5×13	TM6×17
Screw (clamp)		DM6×25 (7.0 Nm)	DM6×30 (7.0 Nm)	DM6×30 (7.0 Nm)
Shim		T16BM	T16BM	T22BM
Wrench (clamp)		WH30L	WH30L	WH30L
Wrench (dowel pin)		WH20L	WH20L	WH30L

Insert

Wiper A87	Finishing A88	Medium Cut A90	Roughing A92	Heavy Turning A97	Cast Iron A99	PCBN/PCD A163

System code > A228

Grade selection > A42

Technical info > A501

Cutting data > A366



A

Turning

B

Milling

C

Drilling

D

Technical Information

E

Index

## TN\*\* holder (external) M-Clamping

MTJNR/L-Z Kr: 93°

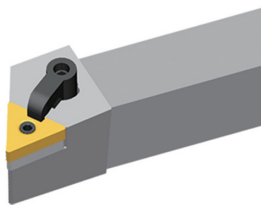

Right hand style

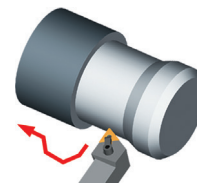
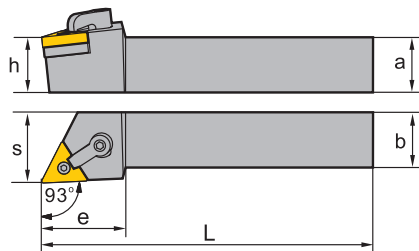

Article	*	Stock		Dimensions [mm]						Inserts
		R	L	a	b	L	h	s	e	
MTJNR/L2020K16-Z	●	●		20	20	125	20	25	32	TN**1604**
MTJNR/L2525M16-Z	●	●		25	25	150	25	32	32	TN**1604**
MTJNR/L3225P16-Z	●	○		32	25	170	32	32	32	TN**1604**
MTJNR/L2525M22-Z	●	●		25	25	150	25	32	36	TN**2204**
MTJNR/L3225P22-Z	●	○		32	25	170	32	32	36	TN**2204**

● Ex stock ○ On demand

\* With internal cooling

Spare parts		TN**1604**	TN**1604**	TN**2204**
Insert h		20	25-32	25-32
	Clamp	C1RD	C1RD	C2RD
	Dowel pin	TM5×13	TM5×13	TM6×17
	Screw (clamp)	DM6×25 (7.0 Nm)	DM6×30 (7.0 Nm)	DM6×30 (7.0 Nm)
	Shim	T16BM	T16BM	T22BM
	Wrench (clamp)	WH30L	WH30L	WH30L
	Wrench (dowel pin)	WH20L	WH20L	WH30L

Insert						
<b>Wiper</b>	<b>Finishing</b>	<b>Medium Cut</b>	<b>Roughing</b>	<b>Heavy Turning</b>	<b>Cast Iron</b>	<b>PCBN/PCD</b>
A87	A88	A90	A92	A97	A99	A163

System code > A228

Grade selection > A42

Technical info > A501

Cutting data > A366

**TN\*\* holder (external)** **M-Clamping**

MTFNR/L Kr: 91°

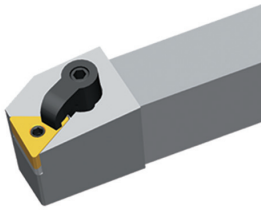

Right hand style

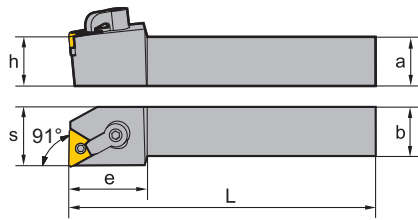

Article	*	Stock		Dimensions [mm]						Inserts
		R	L	a	b	L	h	s	e	
MTFNR/L2020K16	● ○	20	20	125	20	25	32	TN**1604**		
MTFNR/L2525M16	● ●	25	25	150	25	32	32	TN**1604**		
MTFNR/L3225P16	●	32	25	170	32	32	32	TN**1604**		
MTFNR/L2525M22	● ○	25	25	150	25	32	36	TN**2204**		
MTFNR/L3225P22	● ○	32	25	170	32	32	36	TN**2204**		

● Ex stock ○ On demand

\* With internal cooling

Spare parts

	Insert h	TN**1604** 20	TN**1604** 25-32	TN**2204** 25-32
Clamp		C1RD	C1RD	C2RD
Dowel pin		TM5×13	TM5×13	TM6×17
Screw (clamp)		DM6×25 (7.0 Nm)	DM6×30 (7.0 Nm)	DM6×30 (7.0 Nm)
Shim		T16BM	T16BM	T22BM
Wrench (clamp)		WH30L	WH30L	WH30L
Wrench (dowel pin)		WH20L	WH20L	WH30L

Insert

Wiper A87	Finishing A88	Medium Cut A90	Roughing A92	Heavy Turning A97	Cast Iron A99	PCBN/PCD A163



**A**

## VN\*\* holder (external) **M-Clamping**

MVVNN Kr: 72°30'

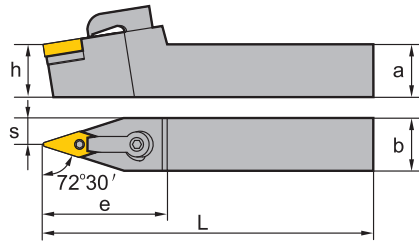
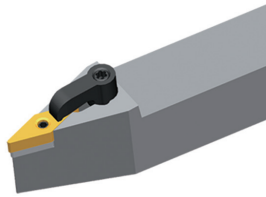

Turning

**B**

Article	*	Stock	Dimensions [mm]						Inserts
			a	b	L	h	s	e	
MVVNN2020K16	●	●	20	20	125	20	10	45	VN**1604**
MVVNN2525M16	●	●	25	25	150	25	12.5	45	VN**1604**
MVVNN3225P16	○	○	32	25	170	32	12.5	45	VN**1604**
MVVNN3232P16	●	●	32	32	170	32	16	45	VN**1604**

● Ex stock ○ On demand

\* With internal cooling

Milling

**C**

Spare parts			
	Insert	VN**1604**	VN**1604**
	h	20	25-32
	Clamp	C3RD	C3RD
	Dowel pin	TM5×13	TM5×13
	Screw (clamp)	DM6×25 (7.0 Nm)	DM6×30 (7.0 Nm)
	Shim	V16BM	V16BM
	Wrench (clamp)	WH30L	WH30L
	Wrench (dowel pin)	WH20L	WH20L

Drilling

**D**

Insert				
<b>Finishing</b>	<b>Medium Cut</b>	<b>Roughing</b>	<b>Cast Iron</b>	<b>PCBN/PCD</b>
A102	A102	A104	A103	A179

Technical Information

**E**

Index

System code > A228

Grade selection > A42

Technical info > A501

Cutting data > A366

## VN\*\* holder (external) M-Clamping

MVJNR/L Kr: 93°

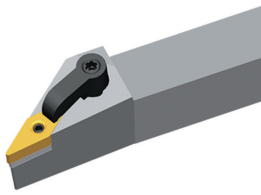

Right hand style

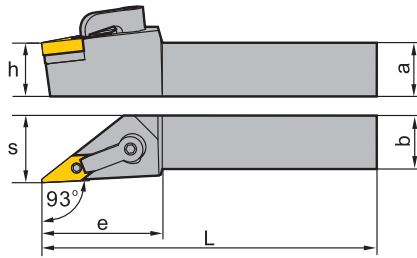

Article	*	Stock		Dimensions [mm]						Inserts
		R	L	a	b	L	h	s	e	
MVJNR/L2020K16	●	●		20	20	125	20	25	45	VN**1604**
MVJNR/L2525M16	●	●		25	25	150	25	32	45	VN**1604**
MVJNR/L3225P16	●	●		32	25	170	32	32	45	VN**1604**
MVJNR/L3232P16	●	●		32	32	170	32	40	45	VN**1604**

● Ex stock ○ On demand

\* With internal cooling

### Spare parts

	Insert	VN**1604**	VN**1604**
	h	20	25-32
	Clamp	C3RD	C3RD
	Dowel pin	TM5×13	TM5×13
	Screw (clamp)	DM6×25 (7.0 Nm)	DM6×30 (7.0 Nm)
	Shim	V16BM	V16BM
	Wrench (clamp)	WH30L	WH30L
	Wrench (dowel pin)	WH20L	WH20L

### Insert

Finishing A102	Medium Cut A102	Roughing A104	Cast Iron A103	PCBN/PCD A179

System code > A228

Grade selection > A42

Technical info > A501

Cutting data > A366

## WN\*\* holder (external) M-Clamping

MWLNLR/L Kr: 95°

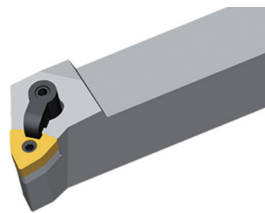

Right hand style

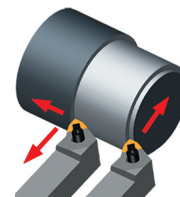
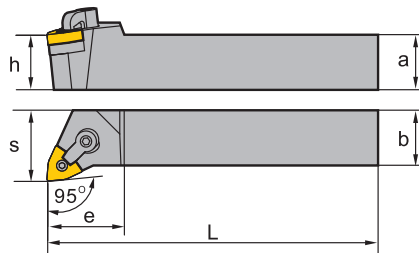

Article	*	Stock		Dimensions [mm]						Inserts
		R	L	a	b	L	h	s	e	
MWLNLR/L2020K06	●	●		20	20	125	20	25	30	WN**0604**
MWLNLR/L2525M06	●	●		25	25	150	25	32	30	WN**0604**
MWLNLR/L2020K08	●	●		20	20	125	20	25	30	WN**0804**
MWLNLR/L2525M08	●	●		25	25	150	25	32	35	WN**0804**
	○			25	25	170	25	32	35	WN**0804**
MWLNLR/L3232P08	●	●		32	32	170	32	40	35	WN**0804**

● Ex stock ○ On demand

\* With internal cooling

### Spare parts

	Insert h	WN**0604**	WN**0604**	WN**0804**	WN**0804**
		20	25	20	25-32
Clamp		C1RD	C1RD	C1RD	C1RD
Dowel pin		TM5×13	TM5×13	TM6×17	TM6×17
Screw (clamp)		DM6×25 (7.0 Nm)	DM6×30 (7.0 Nm)	DM6×25 (7.0 Nm)	DM6×30 (7.0 Nm)
Shim		W06BM	W06BM	W08BM	W08BM
Wrench (clamp)		WH30L	WH30L	WH30L	WH30L
Wrench (dowel pin)		WH20L	WH20L	WH30L	WH30L

### Insert

Wiper A106	Finishing A107	Medium Cut A107	Roughing A109	Cast Iron A111	PCBN/PCD A165

System code > A228

Grade selection > A42

Technical info > A501

Cutting data > A366

**RN\*\* holder (external)** **M-Clamping**

MRDNN

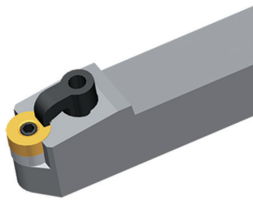

Right hand style

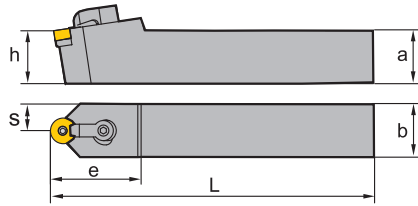

Article	*	Stock	Dimensions [mm]						Inserts
			a	b	L	h	s	e	
MRDNN2020K12		○	20	20	125	20	10	35	RN**1204**
MRDNN2525M12		○	25	25	150	25	12.5	35	RN**1204**
MRDNN3225P12		○	32	25	170	32	12.5	35	RN**1204**
MRDNN3232P12		○	32	32	170	32	16	35	RN**1204**

● Ex stock ○ On demand

\* With internal cooling

Spare parts			
	Insert	RN**1204**	RN**1204**
	h	20	25-32
	Clamp	C1RD	C1RD
	Dowel pin	TM6x17	TM6x17
	Screw (clamp)	DM6x25 (7.0 Nm)	DM6x30 (7.0 Nm)
	Shim	R12BM	R12BM
	Wrench (clamp)	WH30L	WH30L
	Wrench (dowel pin)	WH30L	WH30L

Insert
<b>Cast Iron</b>
A112

System code > A228

Grade selection > A42

Technical info > A501

Cutting data > A366



A

Turning

B

Milling

C

Drilling

D

Technical Information

E

Index

## RN\*\* holder (external) M-Clamping

MRGNR/L

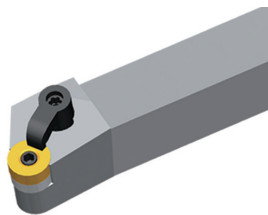

Right hand style

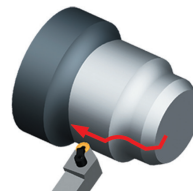
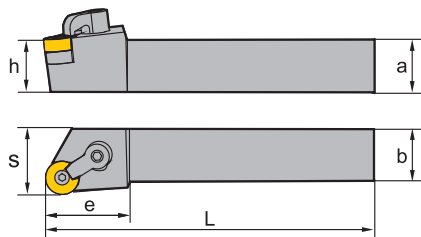







Article	*	Stock		Dimensions [mm]						Inserts
		R	L	a	b	L	h	s	e	
MRGNR/L2020K12		○	○	20	20	125	20	25	32	RN**1204**
MRGNR/L2525M12		○	●	25	25	150	25	32	32	RN**1204**
MRGNR/L3225P12		○	○	32	25	170	32	32	32	RN**1204**
MRGNR/L3232P12		○	○	32	32	170	32	40	32	RN**1204**

● Ex stock ○ On demand

\* With internal cooling

### Spare parts

	Insert	RN**1204**	RN**1204**
	h	20	25-32
	Clamp	C1RD	C1RD
	Dowel pin	TM6×17	TM6×17
	Screw (clamp)	DM6×25 (7.0 Nm)	DM6×30 (7.0 Nm)
	Shim	R12BM	R12BM
	Wrench (clamp)	WH30L	WH30L
	Wrench (dowel pin)	WH30L	WH30L

Insert



Cast Iron

A112

System code > A228

Grade selection > A42

Technical info > A501

Cutting data > A366

**CC\*\* holder (external)** S-Clamping

SCACR/L Kr: 90°

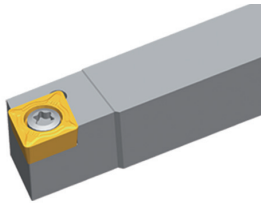

Right hand style

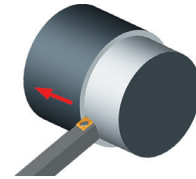
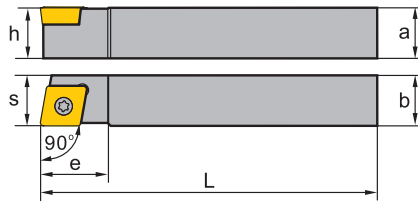



Article	*	Stock		Dimensions [mm]						Inserts
		R	L	a	b	L	h	s	e	
SCACR/L1010E06	•	•		10	10	70	10	10.5	10	CC**0602**
SCACR/L1212F09	•	•		12	12	80	12	12.7	16	CC**09T3**







● Ex stock ○ On demand

\* With internal cooling

Spare parts

	Insert	CC**0602**	CC**09T3**
	h	10	12
	Screw	I60M2.5x6.5 (1.0 Nm)	I60M3.5x8 (2.7 Nm)
	Wrench (screw)	WT07IP	WT15IP

Insert

					
<b>Finishing</b>	<b>Medium Cut</b>	<b>Roughing</b>	<b>Alum Machining</b>	<b>Cast Iron</b>	<b>PCBN/PCD</b>
A116	A119	A121	A122	A121	A180

System code > A228

Grade selection > A42

Technical info > A501

Cutting data > A366



A

Turning

B

Milling

C

Drilling

D

Technical Information

E

Index

## CC\*\* holder (external) S-Clamping

SCLCR/L Kr: 95°

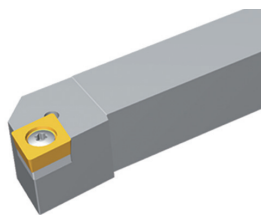

Right hand style

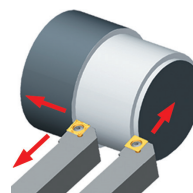
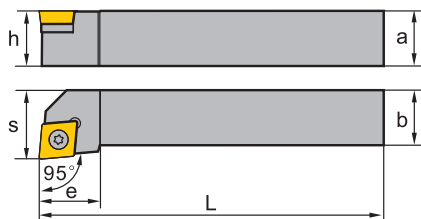

Article	*	Stock		Dimensions [mm]							Inserts
		R	L	a	b	L	h	s	L <sub>2</sub>	e	
SCLCR/L0808D06	●	●	8	8	60	8	10	10	10	CC**0602**	
SCLCR/L1010E06	●	●	10	10	70	10	12	10	10	CC**0602**	
SCLCR/L1212F09	●	●	12	12	80	12	16	16	16	CC**09T3**	
SCLCR/L1616H09	●	●	16	16	100	16	20	16	16	CC**09T3**	
SCLCR/L2020K09	●	●	20	20	125	20	25	25	25	CC**09T3**	
SCLCR/L1616H12	●	●	16	16	100	16	20	18	18	CC**1204**	
SCLCR/L2020K12	●	●	20	20	125	20	25	25	25	CC**1204**	
SCLCR/L2525M12	●	●	25	25	150	25	32	26	26	CC**1204**	
SCLCR/L3225P12	○	○	32	25	170	32	32	26	26	CC**1204**	
SCLCR/L3232P12	●	●	32	32	170	32	40	28	28	CC**1204**	

● Ex stock ○ On demand

\* With internal cooling

### Spare parts

	Insert	CC**0602**	CC**09T3**	CC**1204**
		h	8-10	12-20
	Screw	I60M2.5×6.5 (1.0 Nm)	I60M3.5×8 (2.7 Nm)	
	Screw			I60M4×11X (3.4 Nm)
	Screw (shim)			SM6×10XA
	Shim			C12BS
	Wrench (screw)	WT07IP	WT15IP	WT15IP
	Wrench (shim)			WH40L

### Insert

<b>Finishing</b>	<b>Medium Cut</b>	<b>Roughing</b>	<b>Alum Machining</b>	<b>Cast Iron</b>	<b>PCBN/PCD</b>
A116	A119	A121	A122	A121	A180

System code > A228

Grade selection > A42

Technical info > A501

Cutting data > A366

**DC\*\* holder (external)** S-Clamping

SDACR/L Kr: 90°

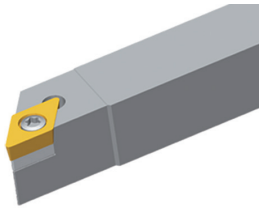

Right hand style

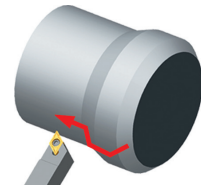
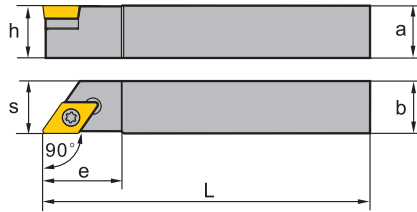

Article	*	Stock		Dimensions [mm]						Inserts
		R	L	a	b	L	h	s	e	
SDACR/L1010E07		●	●	10	10	70	10	10.5	15	DC**0702**
SDACR/L1212F11		●	●	12	12	80	12	12.5	15	DC**11T3**
SDACR/L1616H11		●	●	16	16	100	16	16.7	24	DC**11T3**

● Ex stock ○ On demand

\* With internal cooling

Spare parts

	Insert	DC**0702**	DC**11T3**	DC**11T3**
	h	10	12	16
	Screw	I60M2.5x6.5 (1.0 Nm)	I60M3.5x8 (2.7 Nm)	I60M3.5x12 (2.7 Nm)
	Screw (shim)			SM5x8.65XA
	Shim			D11BS
	Wrench (screw)	WT07IP	WT15IP	WT15IP
	Wrench (shim)			WH35L

Insert

<b>Finishing</b> A126	<b>Medium Cut</b> A127	<b>Roughing</b> A129	<b>Alum Machining</b> A129	<b>Cast Iron</b> A129	<b>PCBN/PCD</b> A184

System code > A228

Grade selection > A42

Technical info > A501

Cutting data > A366



A

Turning

B

Milling

C

Drilling

D

Technical Information

E

Index



## DC\*\* holder (external) S-Clamping

SDJCR/L Kr: 93°

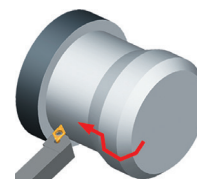
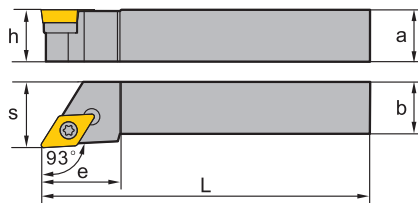
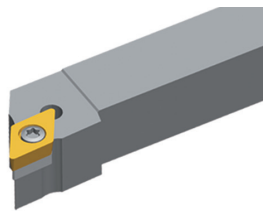





Right hand style

Article	*	Stock		Dimensions [mm]						Inserts
		R	L	a	b	L	h	s	e	
SDJCR/L1010E07	•	•		10	10	70	10	12	15	DC**0702**
SDJCR/L1212F07	•	•		12	12	80	12	16	15	DC**0702**
SDJCR/L1616H07	•	•		16	16	100	16	20	18	DC**0702**
SDJCR/L1616H11	•	•		16	16	100	16	20	24	DC**11T3**
SDJCR/L2020K11	•	•		20	20	125	20	25	24	DC**11T3**
SDJCR/L2525M11	•	•		25	25	150	25	32	29	DC**11T3**
SDJCR/L3225P11	•	•		32	25	170	32	32	29	DC**11T3**







● Ex stock ○ On demand

\* With internal cooling

### Spare parts

	Insert	DC**0702**	DC**11T3**
	h	10-16	16-32
 Screw		I60M2.5×6.5 (1.0 Nm)	I60M3.5×12 (2.7 Nm)
 Screw (shim)			SM5×8.65XA
 Shim			D11BS
 Wrench (screw)		WT07IP	WT15IP
 Wrench (shim)			WH35L

### Insert

					
Finishing A126	Medium Cut A127	Roughing A129	Alum Machining A129	Cast Iron A129	PCBN/PCD A184

System code > A228

Grade selection > A42

Technical info > A501

Cutting data > A366

**DC\*\* holder (external)** S-Clamping

SDNCN Kr: 62°30'

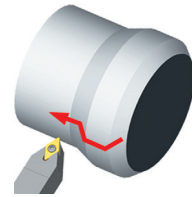
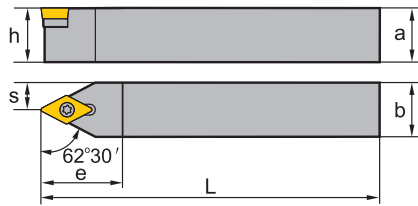
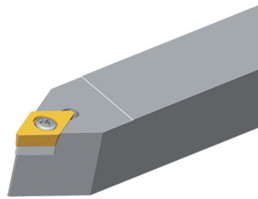

Article	*	Stock	Dimensions [mm]						Inserts
			a	b	L	h	s	e	
SDNCN1010E07	●		10	10	70	10	5	20	DC**0702**
SDNCN1212F07	●		12	12	80	12	6	20	DC**0702**
SDNCN1212H11	●		12	12	100	12	6	30	DC**11T3**
SDNCN1616H11	●		16	16	100	16	8	30	DC**11T3**
SDNCN2020K11	●		20	20	125	20	10	30	DC**11T3**
SDNCN2525M11	●		25	25	150	25	12.5	30	DC**11T3**

● Ex stock ○ On demand

\* With internal cooling

Spare parts				
	Insert	DC**0702**	DC**11T3**	DC**11T3**
	h	10-12	12	16-25
	Screw	I60M2.5x6.5 (1.0 Nm)	I60M3.5x8 (2.7 Nm)	I60M3.5x12 (2.7 Nm)
	Screw (shim)			SM5x8.65XA
	Shim			D11BS
	Wrench (screw)	WT07IP	WT15IP	WT15IP
	Wrench (shim)			WH35L

Insert					
Finishing	Medium Cut	Roughing	Alum Machining	Cast Iron	PCBN/PCD
A126	A127	A129	A129	A129	A184

System code > A228

Grade selection > A42

Technical info > A501

Cutting data > A366

## VB\*\* holder (external) S-Clamping

SVJBR/L Kr: 93°

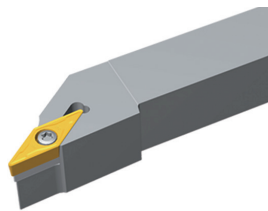

Right hand style

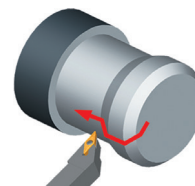
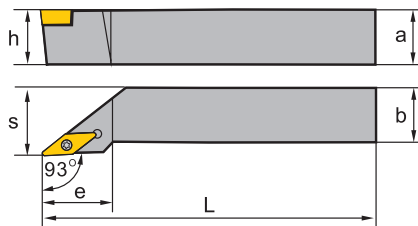





Article	*	Stock		Dimensions [mm]						Inserts
		R	L	a	b	L	h	s	e	
SVJBR/L1212F11		●		12	12	80	12	16	27	VB**1103**
SVJBR/L1616H11		●	●	16	16	100	16	20	27	VB**1103**
SVJBR/L2525M11		●	●	25	25	150	25	32	27	VB**1103**
SVJBR/L1616H16		●	●	16	16	100	16	20	36	VB**1604**
SVJBR/L2020K16		●	●	20	20	125	20	25	41	VB**1604**
SVJBR/L2525M16		●	●	25	25	150	25	32	41	VB**1604**
SVJBR/L3225P16		●	●	32	25	170	32	32	41	VB**1604**





● Ex stock ○ On demand

\* With internal cooling

### Spare parts

	Insert	VB**1103**	VB**1604**
	h	12-25	16-32
	Screw	I60M2.5×6.5 (1.0 Nm)	I60M3.5×12 (2.7 Nm)
	Screw (shim)		SM5×8.65XA
	Shim		V16BS
	Wrench (screw)	WT07IP	WT15IP
	Wrench (shim)		WH35L

### Insert

			
Finishing	Medium Cut	Roughing	PCBN/PCD
A148	A151	A152	A191

System code > A228

Grade selection > A42

Technical info > A501

Cutting data > A366

**VB\*\* holder (external) S-Clamping**

SVABR/L Kr: 90°

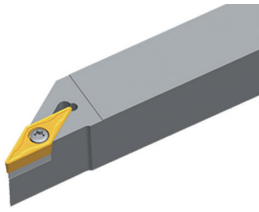

Right hand style

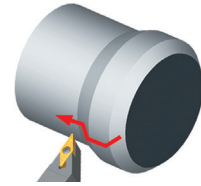
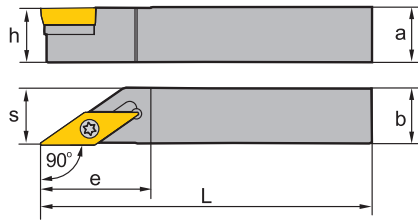





Article	*	Stock		Dimensions [mm]						Inserts
		R	L	a	b	L	h	s	e	
SVABR/L1010F11	●	●	10	10	80	10	10.5	28	VB**1103**	
SVABR/L1616H16	●	○	16	16	100	16	16.5	28	VB**1604**	
SVABR/L2020K16	●	○	20	20	125	20	20.5	28	VB**1604**	
SVABR/L2525M16	●	●	25	25	150	25	25.5	28	VB**1604**	





● Ex stock ○ On demand

\* With internal cooling

Spare parts

	Insert	VB**1103**	VB**1604**
	h	10	16-32
	Screw	I60M2.5×6.5 (1.0 Nm)	I60M3.5×12 (2.7 Nm)
	Screw (shim)		SM5×8.65XA
	Shim		V16BS
	Wrench (screw)	WT07IP	WT15IP
	Wrench (shim)		WH35L

Insert

			
<b>Finishing</b>	<b>Medium Cut</b>	<b>Roughing</b>	<b>PCBN/PCD</b>
A148	A151	A152	A191

**A**

## VB\*\* holder (external) S-Clamping

SVVBN Kr: 72°30'

Turning

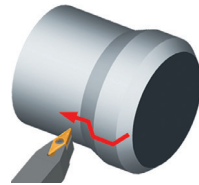
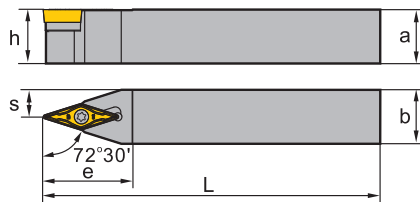
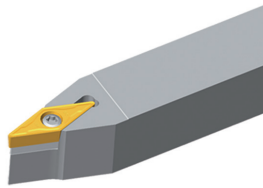

**B**

Milling





Article	*	Stock	Dimensions [mm]						Inserts
			a	b	L	h	s	e	
SVVBN1616H11	●		16	16	100	16	8	27	VB**1103**
SVVBN2020K11	●		20	20	125	20	10	30	VB**1103**
SVVBN1616H16	●		16	16	100	16	8	33	VB**1604**
SVVBN2020K16	●		20	20	125	20	10	33	VB**1604**
SVVBN2525M16	●		25	25	150	25	12.5	38	VB**1604**

● Ex stock ○ On demand

\* With internal cooling





**C**

Drilling

Spare parts			
	Insert	VB**1103**	VB**1604**
	h	12-25	16-32
	Screw	I60M2.5×6.5 (1.0 Nm)	I60M3.5×12 (2.7 Nm)
	Screw (shim)		SM5×8.65XA
	Shim		V16BS
	Wrench (screw)	WT07IP	WT15IP
	Wrench (shim)		WH35L

**D**

Technical Information

Insert			
			
Finishing A148	Medium Cut A151	Roughing A152	PCBN/PCD A191

**E**

Index

System code > A228

Grade selection > A42

Technical info > A501

Cutting data > A366

**VC\*\* holder (external)** S-Clamping

SVVCN Kr: 72°30'

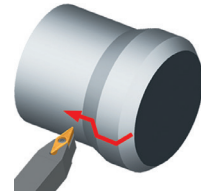
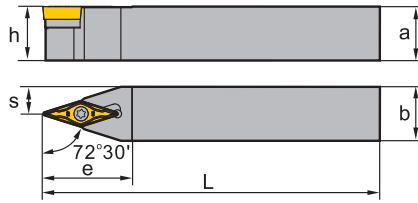
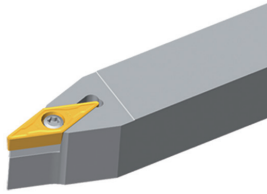

Article	*	Stock	Dimensions [mm]						Inserts
			a	b	L	h	s	e	
SVVCN1212F11		●	12	12	80	12	6	27	VC**1103**
SVVCN1616H11		●	16	16	100	16	8	27	VC**1103**
SVVCN2020K11		●	20	20	125	20	10	30	VC**1103**
SVVCN1212M11		●	12	12	150	12	6	27	VC**1103**
SVVCN2525M11		●	25	25	150	25	12.5	38	VC**1103**
SVVCN1616H16		●	16	16	100	16	8	33	VC**1604**
SVVCN2020K16		●	20	20	125	20	10	33	VC**1604**
SVVCN2525M16		●	25	25	150	25	12.5	38	VC**1604**

● Ex stock ○ On demand

\* With internal cooling

Spare parts			
	Insert	VC**1103**	VC**1604**
		12-25	16-32
	Screw	I60M2.5×6.5 (1.0 Nm)	I60M3.5×12 (2.7 Nm)
	Screw (shim)		SM5×8.65XA
	Shim		V16BSC
	Wrench (screw)	WT07IP	WT15IP
	Wrench (shim)		WH35L

Insert			
Finishing	Medium Cut	Alum Machining	PCBN/PCD
A156	A156	A154	A193

## VC\*\* holder (external) S-Clamping

SVJCR/L Kr: 93°

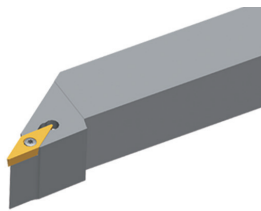

Right hand style

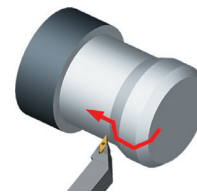
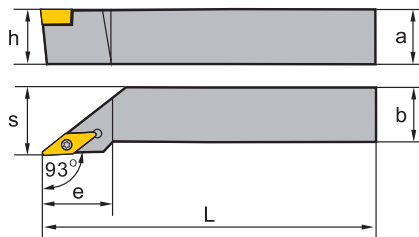

Article	*	Stock		Dimensions [mm]						Inserts
		R	L	a	b	L	h	s	e	
SVJCR/L1010E11	●			10	10	70	10	12	22	VC**1103**
SVJCR/L1212F11	●	●		12	12	80	12	16	27	VC**1103**
SVJCR/L1616H11	●	●		16	16	100	16	20	27	VC**1103**
SVJCR/L2020K11	●	●		20	20	125	20	25	27	VC**1103**
SVJCR/L2525M11	●	●		25	25	150	25	32	27	VC**1103**
SVJCR/L1616H16	●	●		16	16	100	16	20	36	VC**1604**
SVJCR/L2020K16	●	●		20	20	125	20	25	41	VC**1604**
SVJCR/L2020M16	●	●		20	20	150	20	25	41	VC**1604**
SVJCR/L2525M16	●	●		25	25	150	20	32	41	VC**1604**
SVJCR/L3225P16	○	○		32	25	170	32	32	41	VC**1604**

● Ex stock ○ On demand

\* With internal cooling

### Spare parts

	Insert	VC**1103**	VC**1604**
		10-25	16-32
	Screw	I60M2.5×6.5 (1.0 Nm)	I60M3.5×12 (2.7 Nm)
	Screw (shim)		SM5×8.65XA
	Shim		V16BSC
	Wrench (screw)	WT07IP	WT15IP
	Wrench (shim)		WH35L

### Insert

Finishing	Medium Cut	Alum Machining	PCBN/PCD
A156	A156	A154	A193

System code > A228

Grade selection > A42

Technical info > A501

Cutting data > A366

**SC\*\* steel boring bar S-Clamping**

SSBCR/L Kr: 75°

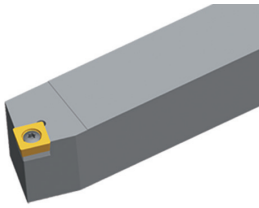

Right hand style

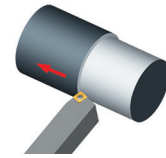
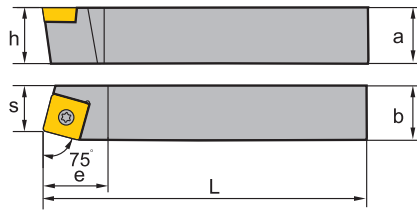







Article	*	Stock		Dimensions [mm]						Inserts
		R	L	a	b	L	h	s	e	
SSBCR/L1212F09	•	•	12	12	80	12	11	16	SC**09T3**	
SSBCR/L1616H09	•	•	16	16	100	16	13	16	SC**09T3**	
SSBCR/L2020K12	•	•	20	20	125	20	17	25	SC**1204**	





• Ex stock    ○ On demand

\* With internal cooling

Spare parts

	Insert	SC**09T3**	SC**09T3**	SC**1204**
	h	12	16	20
	Screw	I60M3.5x8 (2.7 Nm)	I60M3.5x8 (2.7 Nm)	
	Screw			I60M4x11X (3.4 Nm)
	Screw (shim)		SM5x8.65XA	SM6x10XA
	Shim		S09BS	S12BS
	Wrench (screw)	WT15IP	WT15IP	WT15IP
	Wrench (shim)		WH35L	WH40L

Insert

			
<b>Finishing</b> A134	<b>Medium Cut</b> A135	<b>Roughing</b> A136	<b>Alum Machining</b> A136

System code > A228

Grade selection > A42

Technical info > A501

Cutting data > A366



**A**

## SC\*\* steel boring bar S-Clamping

SSDCN Kr: 45°

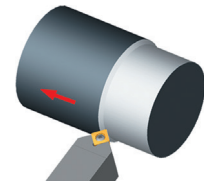
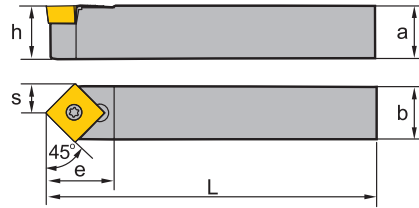
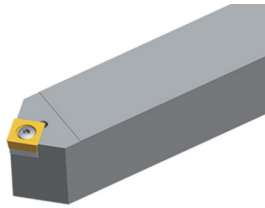

Right hand style

Turning

**B**

Article	*	Stock	Dimensions [mm]						Inserts
			a	b	L	h	s	e	
SSDCN1212F09	●		12	12	80	12	6	15.5	SC**09T3**
SSDCN1616H09	●		16	16	100	16	8	15.5	SC**09T3**





Milling

● Ex stock ○ On demand

\* With internal cooling

**C**





### Spare parts

	Insert	SC**09T3**	SC**09T3**
	h	12	16
	Screw	I60M3.5×8 (2.7 Nm)	I60M3.5×8 (2.7 Nm)
	Screw (shim)		SM5×8.65XA
	Shim		S09BS
	Wrench (screw)	WT15IP	WT15IP
	Wrench (shim)		WH35L

Drilling

**D**

### Insert

			
Finishing	Medium Cut	Roughing	Alum Machining
A134	A135	A136	A136

Technical Information

**E**

Index

System code > A228

Grade selection > A42

Technical info > A501

Cutting data > A366

**SC\*\* steel boring bar S-Clamping**

SSKCR/L Kr: 75°

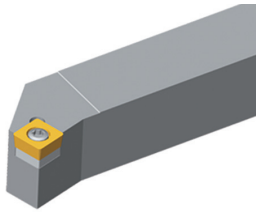

Right hand style

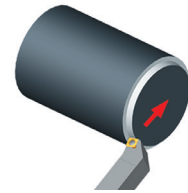
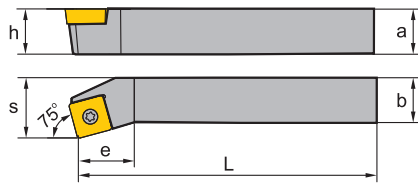





Article	*	Stock		Dimensions [mm]						Inserts
		R	L	a	b	L	h	s	e	
<b>SSKCR/L1616H09</b>		●	●	16	16	100	16	20	13	SC**09T3**





● Ex stock ○ On demand

\* With internal cooling

Spare parts

	Insert	SC**09T3**
	<b>h</b>	<b>16</b>
	Screw	I60M3.5×8 (2.7 Nm)
	Screw (shim)	SM5×8.65XA
	Shim	S09BS
	Wrench (screw)	WT15IP
	Wrench (shim)	WH35L

Insert

			
<b>Finishing</b>	<b>Medium Cut</b>	<b>Roughing</b>	<b>Alum Machining</b>
A134	A135	A136	A136

System code > A228

Grade selection > A42

Technical info > A501

Cutting data > A366

## SC\*\* steel boring bar S-Clamping

SSSCR/L Kr: 45°

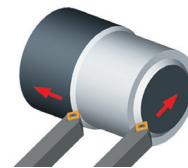
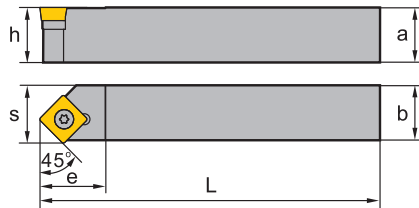
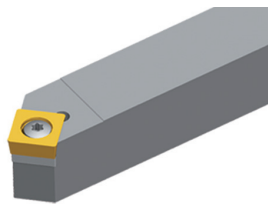

Right hand style

Article	*	Stock		Dimensions [mm]						Inserts
		R	L	a	b	L	h	s	e	
SSSCR/L1616H09	●	●		16	16	100	16	17	17	SC**09T3**
SSSCR/L2020K12	●	●		20	20	125	20	21	21	SC**1204**

● Ex stock ○ On demand

\* With internal cooling

### Spare parts

	Insert	SC**09T3**	SC**1204**
	h	16	20
	Screw	I60M3.5×12 (2.7 Nm)	
	Screw		I60M4×11X (3.4 Nm)
	Screw (shim)		SM6×10XA
	Shim		S12BS
	Wrench (screw)	WT15IP	WT15IP
	Wrench (shim)		WH40L

### Insert

<b>Finishing</b>	<b>Medium Cut</b>	<b>Roughing</b>	<b>Alum Machining</b>
A134	A135	A136	A136

System code > A228

Grade selection > A42

Technical info > A501

Cutting data > A366

**TC\*\* holder (external) S-Clamping**

STACR/L Kr: 90°

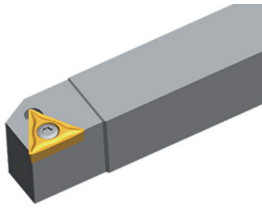

Right hand style

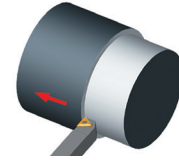
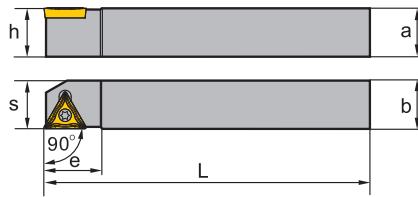



Article	*	Stock		Dimensions [mm]						Inserts
		R	L	a	b	L	h	s	e	
STACR/L1212F11		●	●	12	12	80	12	12.5	14	TC**1102**

● Ex stock ○ On demand

\* With internal cooling

Spare parts

	Insert	TC**1102**
	h	12
	Screw	I60M2.5x6.5 (1.0 Nm)
	Wrench (screw)	WT07IP

Insert

				
Finishing A141	Medium Cut A142	Roughing A143	Alum Machining A145	PCBN/PCD A187

A

Turning

B

Milling

C

Drilling

D

Technical Information

E

Index

System code > A228

Grade selection > A42

Technical info > A501

Cutting data > A366

**A**

## TC\*\* holder (external) S-Clamping

STFCR/L Kr: 91°

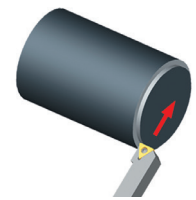
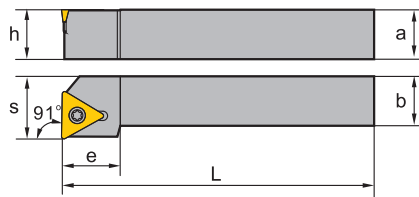
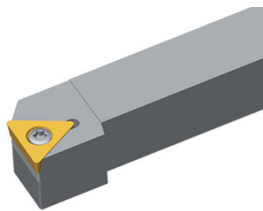

Right hand style

Turning

**B**

Article	*	Stock		Dimensions [mm]						Inserts
		R	L	a	b	L	h	s	e	
STFCR/L1212F11	● ○			12	12	80	12	16	14	TC**1102**
STFCR/L1616H11	● ○			16	16	100	16	20	14	TC**1102**
STFCR/L1616H16	● ○			16	16	100	16	20	19	TC**16T3**
STFCR/L2020K16	● ●			20	20	125	20	25	19	TC**16T3**

● Ex stock ○ On demand

\* With internal cooling

Milling

**C**

### Spare parts

	Insert	TC**1102**	TC**16T3**
	h	12-16	16-20
	Screw	I60M2.5×6.5 (1.0 Nm)	I60M3.5×12 (2.7 Nm)
	Screw (shim)		SM5×8.65XA
	Shim		T16BS
	Wrench (screw)	WT07IP	WT15IP
	Wrench (shim)		WH35L

Drilling

**D**

### Insert

<b>Finishing</b>	<b>Medium Cut</b>	<b>Roughing</b>	<b>Alum Machining</b>	<b>Cast Iron</b>	<b>PCBN/PCD</b>
A141	A142	A143	A145	A143	A187

Technical Information

**E**

Index

System code > A228

Grade selection > A42

Technical info > A501

Cutting data > A366

TC\*\* holder (external) **S-Clamping**

STGCR/L Kr: 91°

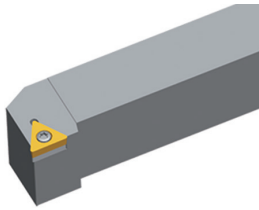

Right hand style

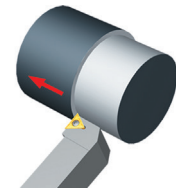

Article	*	Stock		Dimensions [mm]						Inserts
		R	L	a	b	L	h	s	e	
STGCR/L0808D09	○			8	8	60	8	10	11	TC**0902**
STGCR/L1010E09	●	○		10	10	70	10	12	11	TC**0902**
STGCR/L1212F11	●	●		12	12	80	12	16	14	TC**1102**
STGCR/L1616H11	●	●		16	16	100	16	20	16	TC**1102**
STGCR/L2020K16	●	●		20	20	125	20	25	21	TC**16T3**
STGCR/L2525M16	●	●		25	25	150	25	25	21	TC**16T3**

● Ex stock ○ On demand

\* With internal cooling

Spare parts		TC**0902**	TC**1102**	TC**16T3**
Insert h		8-10	12-16	20-25
	Screw	I60M2.2x5.5 (0.8 Nm)	I60M2.5x6.5 (1.0 Nm)	I60M3.5x12 (2.7 Nm)
	Screw (shim)			SM5x8.65XA
	Shim			T16BS
	Wrench (screw)	WT06IP	WT07IP	WT15IP
	Wrench (shim)			WH35L

Insert					
Finishing A141	Medium Cut A142	Roughing A143	Alum Machining A145	Cast Iron A143	PCBN/PCD A187

System code > A228

Grade selection > A42

Technical info > A501

Cutting data > A366



A

Turning

B

Milling

C

Drilling

D

Technical Information

E

Index

**A**

Turning

## TC\*\* holder (external) **S-Clamping**

STTCR/L Kr: 60°

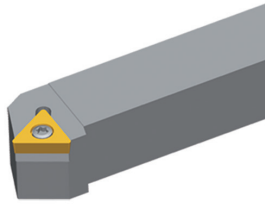

Right hand style

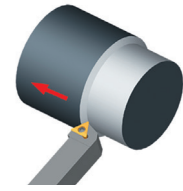

**B**

Milling

Article	*	Stock		Dimensions [mm]						Inserts
		R	L	a	b	L	h	s	e	
STTCR/L1616H11	● ○	●	○	16	16	100	16	13	14	TC**1102**
STTCR/L1616H16	● ●	●	●	16	16	100	16	13	19	TC**16T3**
STTCR/L2020K16	● ●	●	●	20	20	125	20	17	19	TC**16T3**

● Ex stock ○ On demand

\* With internal cooling

**C**

Drilling

### Spare parts

	Insert	TC**1102**	TC**16T3**
	<b>h</b>	<b>16</b>	<b>16-20</b>
	Screw	I60M2.5×6.5 (1.0 Nm)	I60M3.5×12 (2.7 Nm)
	Screw (shim)		SM5×8.65XA
	Shim		T16BS
	Wrench (screw)	WT07IP	WT15IP
	Wrench (shim)		WH35L

**D**

Technical Information

### Insert

<b>Finishing</b>	<b>Medium Cut</b>	<b>Roughing</b>	<b>Alum Machining</b>	<b>Cast Iron</b>	<b>PCBN/PCD</b>
A141	A142	A143	A145	A143	A187

**E**

Index

System code > A228

Grade selection > A42

Technical info > A501

Cutting data > A366

**WC\*\* holder (external) S-Clamping**

SWACR/L Kr: 90°

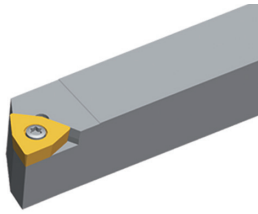

Right hand style

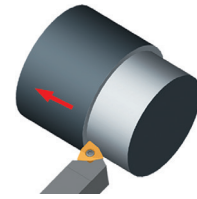
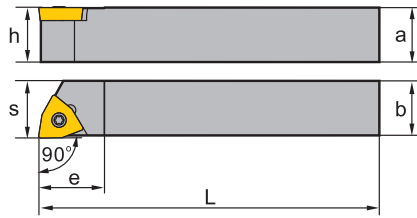

Article	*	Stock		Dimensions [mm]						Inserts
		R	L	a	b	L	h	s	e	
SWACR/L1010E04		●	○	10	10	70	10	10.5	10	WC**0402**
SWACR/L1212F04		●	○	12	12	80	12	12	14	WC**0402**
SWACR/L1616H06		●	●	16	16	100	16	16.5	20	WC**06T3**
SWACR/L2020K08		●	●	20	20	125	20	20.5	24	WC**0804**

● Ex stock ○ On demand

\* With internal cooling

Spare parts

	Insert	WC**0402**	WC**06T3**	WC**0804**
	<b>h</b>	<b>10-12</b>	<b>16</b>	<b>20</b>
	Screw	I60M2.5×6.5 (1.0 Nm)	I60M3×7 (1.8 Nm)	I60M3.5×12 (2.7 Nm)
	Wrench (screw)	WT07IP	WT10IP	WT15IP

Insert



Medium Cut

C35



## RC\*\* holder (external) S-Clamping

SRDCN

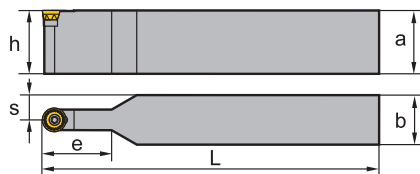
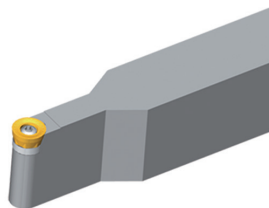

Article	*	Stock	Dimensions [mm]						Inserts	
			a	b	L	h	s	e		
SRDCN1616H08		○	16	16	100	16	8	16	RCGX0803MO	RCMT0803MO
SRDCN2020K08		●	20	20	125	20	10	16	RCGX0803MO	RCMT0803MO
SRDCN2020K12		●	20	20	125	20	10	35	RCGX1204MO	RCMT1204MO
SRDCN2525M12		●	25	25	150	25	12.5	35	RCGX1204MO	RCMT1204MO
SRDCN3225P12		●	32	25	170	32	12.5	35	RCGX1204MO	RCMT1204MO
SRDCN2020K10		●	20	20	125	20	10	25	RCMT10T3MO	
SRDCN2525M10		●	25	25	150	25	12.5	25	RCMT10T3MO	
SRDCN3225P16		●	32	25	170	32	12.5	35	RCMT1606MO	
SRDCN3232P16		●	32	32	170	32	16	40	RCMT1606MO	
SRDCN4040S16		●	40	40	250	40	20	50	RCMT1606MO	
SRDCN4040S20		●	40	40	250	40	20	50	RCMT2006MO	

● Ex stock ○ On demand

\* With internal cooling

### Spare parts

	Insert	RCGX0803MO	RCGX1204MO	RCMT10T3MO	RCMT1606MO	RCMT2006MO
	h	16-20	20-32	20-25	32-40	40
	Screw	I60M3×7 (1.8 Nm)	I60M3.5×12 (2.7 Nm)	I60M3.5×10 (2.7 Nm)		I43M6×16 (9.1 Nm)
	Screw				I60M4×15X (3.4 Nm)	
	Screw (shim)		SM5×8.65XA		SM6×10XA	
	Shim		R12BS		R16BS	
	Wrench (screw)	WT10IP	WT15IP	WT15IP	WT15IP	
	Wrench (screw)					WT25IT
	Wrench (shim)		WH35L		WH40L	

### Insert



**Alum Machining**  
A132



**Cast Iron**  
A132

System code > A228

Grade selection > A42

Technical info > A501

Cutting data > A366

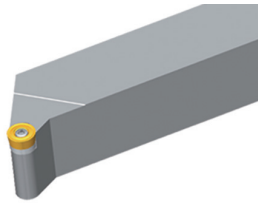

**RC\*\* holder (external) S-Clamping**

SRGCR/L



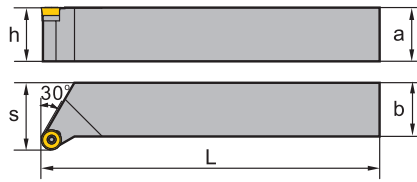



Right hand style





Article	*	Stock		Dimensions [mm]					Inserts	
		R	L	a	b	L	h	s		
SRGCR/L1616H08		●	●	16	16	100	16	20	RCGX0803MO-LH	RCMT0803MO
SRGCR/L2020K12		●	○	20	20	125	20	27	RCGX1204MO	RCMT1204MO
SRGCR/L2525M12		●	○	25	25	150	25	32	RCGX1204MO	RCMT1204MO
SRGCR/L2525M10		●	○	25	25	100	25	32	RCMT10T3MO	
SRGCR/L2020K10		●	○	20	20	125	20	25	RCMT10T3MO	

● Ex stock ○ On demand

\* With internal cooling

Spare parts		RCGX0803MO-LH	RCGX1204MO	RCMT10T3MO
Insert h		16	20-25	16-25
	Screw	I60M3.5×10 (2.7 Nm)	I60M3.5×12 (2.7 Nm)	I60M3.5×10 (2.7 Nm)
	Screw (shim)		SM5×8.65XA	
	Shim		R12BS	
	Wrench (screw)	WT15IP	WT15IP	WT15IP
	Wrench (shim)		WH35L	

Insert	
	
<b>Alum Machining</b>	<b>Cast Iron</b>
A132	A132

System code > A228

Grade selection > A42

Technical info > A501

Cutting data > A366



A

Turning

B

Milling

C

Drilling

D

Technical Information

E

Index

## KNUX\*\* holder C-Clamping

CKJNR/L Kr: 93°

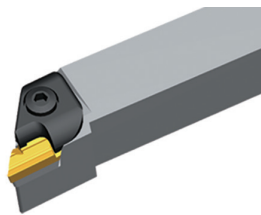

Right hand style

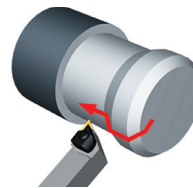
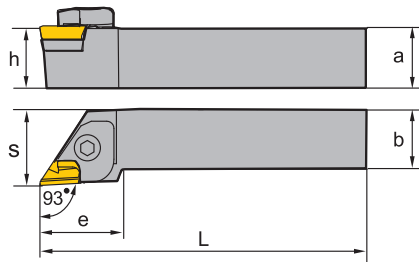

Article	*	Stock		Dimensions [mm]						Inserts
		R	L	a	b	L	h	s	e	
CKJNL2525M16	●			25	25	150	25	32	32	KNUX1604**L
CKJNL3232P16	●			32	32	170	32	40	32	KNUX1604**L
CKJNL4040R16	●			40	40	200	40	50	32	KNUX1604**L
CKJNR2525M16	●			25	25	150	25	32	32	KNUX1604**R
CKJNR3232P16	●			32	32	170	32	40	32	KNUX1604**R
CKJNR4040R16	○			40	40	200	40	50	32	KNUX1604**R

● Ex stock ○ On demand

\* With internal cooling

Spare parts			
	Insert	KNUX1604**L	KNUX1604**R
	h	25-40	25-40
	Clamp	C6L1T	C6R1T
	Dowel pin	P0515	P0515
	Screw (clamp)	CM6×25A (7.0 Nm)	CM6×25A (7.0 Nm)
	Screw (shim)	SM3×10B	SM3×10B
	Shim		K16CC
	Shim	K16CCL	
	Spring (clamp)	SPR1	SPR1
	Spring (dowel pin)	SPR2	SPR2
	Wrench (clamp)	WH40L	WH40L
	Wrench (shim)	WH20L	WH20L

Insert



Finishing

A113

System code > A228

Grade selection > A42

Technical info > A501

Cutting data > A366

**KNUX\*\* holder** **C-Clamping**

CKNNR/L Kr: 63°

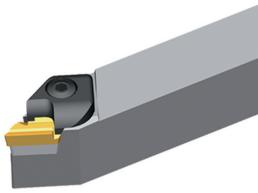

Right hand style

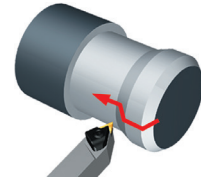
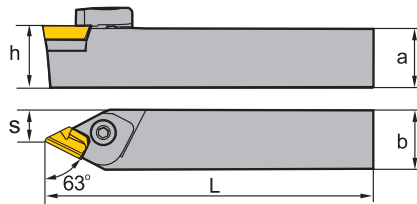

Article	*	Stock		Dimensions [mm]					Inserts
		R	L	a	b	L	h	s	
CKNNL2525M16	●			25	25	150	25	14.3	KNUX1604**L
CKNNL3232P16	○			32	32	170	32	16.8	KNUX1604**L
CKNNR2525M16	●			25	25	150	25	14.3	KNUX1604**R

● Ex stock ○ On demand

\* With internal cooling

Spare parts

	Insert	KNUX1604**L		KNUX1604**R	
		h	25-32	25-32	25-32
	Clamp		C6L1T		C6R1T
	Dowel pin		P0515		P0515
	Screw (clamp)		CM6×25A (7.0 Nm)		CM6×25A (7.0 Nm)
	Screw (shim)		SM3×10B		SM3×10B
	Shim				K16CC
	Shim		K16CCL		
	Spring (clamp)		SPR1		SPR1
	Spring (dowel pin)		SPR2		SPR2
	Wrench (clamp)		WH40L		WH40L
	Wrench (shim)		WH20L		WH20L

Insert



Finishing

A113

System code > A228

Grade selection > A42

Technical info > A501

Cutting data > A366



A

Turning

B

Milling

C

Drilling

D

Technical Information

E

Index

## CN\*\* holder (external) C-Clamping

CCLNR/L Kr: 95°

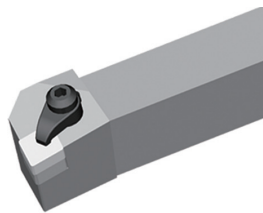

Right hand style

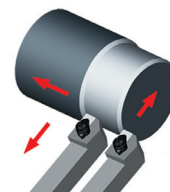
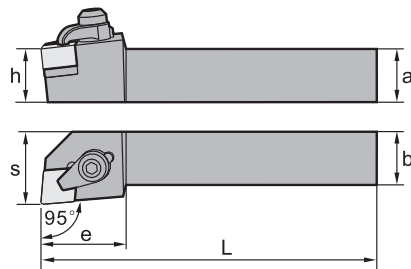

Article	*	Stock		Dimensions [mm]						Inserts	
		R	L	a	b	L	h	s	e		
CCLNR/L2020K12		○	○	20	20	125	20	27	32	CNGN1204**	CNGN1207**
CCLNR/L2525M12		○	●	25	20	100	25	27	36	CNGN1204**	CNGN1207**
CCLNR/L2525M16			○	25	25	150	25	32	36	CNGN1604**	CNGN1606**
CCLNR/L3225P16		○	○	32	25	170	32	32	36	CNGN1604**	CNGN1606**

● Ex stock ○ On demand

\* With internal cooling

### Spare parts

	Insert	CNGN1204**	CNGN1207**	CNGN1604**	CNGN1606**
	h	20-25	20-25	25-32	25-32
	Clamp	C1RC	C1RC	C2RC	C2RC
	Screw (clamp)	CM6×30B (7.0 Nm)	CM6×30B (7.0 Nm)	CM8×30B (10.2 Nm)	CM8×30B (10.2 Nm)
	Screw (shim)	SM3×10B	SM3×10B	SM4×12B	SM4×12B
	Shim	C12CC-04	C12CC-07	C16CC-04	C16CC-06
	Spring	SPR1	SPR1	SPR3	SPR3
	Wrench (clamp)	WH40L	WH40L	WH50L	WH50L
	Wrench (shim)	WH20L	WH20L	WH30L	WH30L

Insert



PCBN/PCD

A173

**TN\*\* holder (external) C-Clamping**

CTJNR/L Kr: 93°

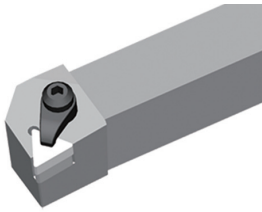

Right hand style

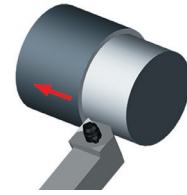
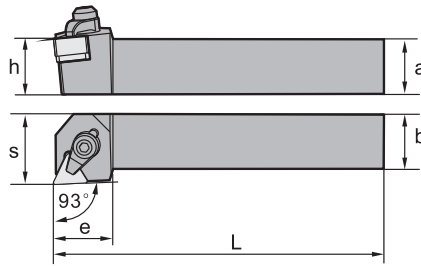

Article	*	Stock		Dimensions [mm]						Inserts	
		R	L	a	b	L	h	s	e		
CTJNR/L2020K16		○	○	20	20	125	20	25	30	TNGN1604**	TNGN1607**
CTJNR/L2525M16		○	○	25	25	150	25	32	30	TNGN1604**	TNGN1607**

● Ex stock ○ On demand

\* With internal cooling

Spare parts

	Insert	TNGN1604**	TNGN1607**
	h	20-25	20-25
	Clamp	C1RC	C1RC
	Screw (clamp)	CM6×30B (7.0 Nm)	CM6×30B (7.0 Nm)
	Screw (shim)	SM3×10B	SM3×10B
	Shim	T16CC-04	T16CC-07
	Spring	SPR1	SPR1
	Wrench (clamp)	WH40L	WH40L
	Wrench (shim)	WH20L	WH20L

Insert



Medium Cut

A218

System code > A228

Grade selection > A42

Technical info > A501

Cutting data > A366



A

Turning

B

Milling

C

Drilling

D

Technical Information

E

Index

## DN\*\* holder (external) C-Clamping

CDJNR/L Kr: 93°

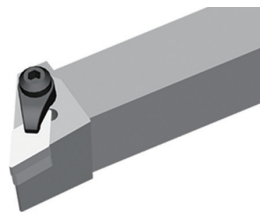

Right hand style

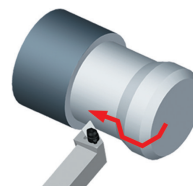
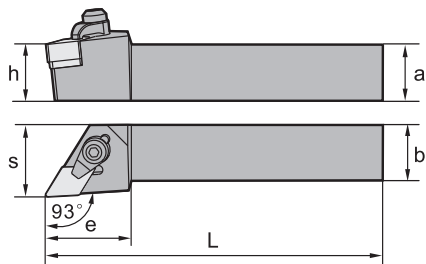

Article	*	Stock		Dimensions [mm]						Inserts	
		R	L	a	b	L	h	s	e		
CDJNR/L2525M15	●	●		25	25	150	25	32	32	DNGN1504**	DNGN1507**
CDJNR/L3225P15	○	○		32	25	170	32	32	32	DNGN1504**	DNGN1507**

● Ex stock ○ On demand

\* With internal cooling

### Spare parts

	Insert	DNGN1504**	DNGN1507**
	h	25-32	25-32
	Clamp	C1RC	C1RC
	Screw (clamp)	CM6×30B (7.0 Nm)	CM6×30B (7.0 Nm)
	Screw (shim)	SM3×10B	SM3×10B
	Shim	D15CC-04	D15CC-07
	Spring	SPR1	SPR1
	Wrench (clamp)	WH40L	WH40L
	Wrench (shim)	WH20L	WH20L

Insert



Medium Cut

A205

System code > A228

Grade selection > A42

Technical info > A501

Cutting data > A366

**TN\*\* holder (external) C-Clamping**

CTUNR/L Kr: 93°

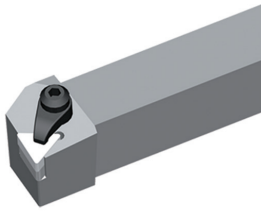

Right hand style

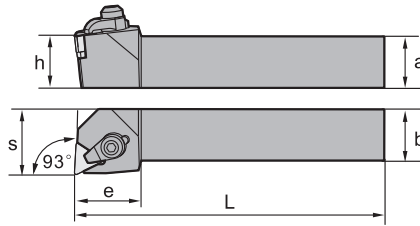

Article	*	Stock		Dimensions [mm]						Inserts	
		R	L	a	b	L	h	s	e		
CTUNR/L2525M16		○	○	25	25	150	25	32	27	TNGN1604**	TNGN1607**

● Ex stock ○ On demand

\* With internal cooling

Spare parts

	Insert h	TNGN1604**	TNGN1607**
		20-25	20-25
	Clamp	C1RC	C1RC
	Screw (clamp)	CM6×30B (7.0 Nm)	CM6×30B (7.0 Nm)
	Screw (shim)	SM3×10B	SM3×10B
	Shim	T16CC-04	T16CC-07
	Spring	SPR1	SPR1
	Wrench (clamp)	WH40L	WH40L
	Wrench (shim)	WH20L	WH20L

Insert



Medium Cut

A218

System code > A228

Grade selection > A42

Technical info > A501

Cutting data > A366



A

Turning

B

Milling

C

Drilling

D

Technical Information

E

Index



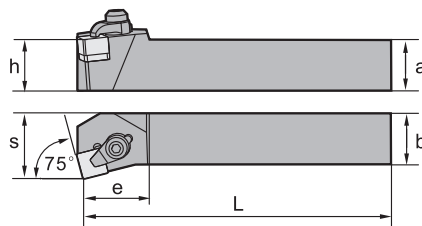
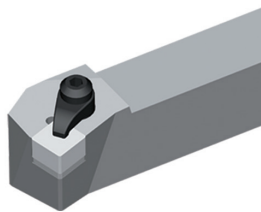

## SN\*\* holder (external) C-Clamping

CSKNR/L Kr: 75°









Right hand style

Article	*	Stock		Dimensions [mm]						Inserts	
		R	L	a	b	L	h	s	e		
CSKNR/L2020K12		○	○	20	20	125	20	25	25	SNGN1204**	SNGN1207**
CSKNR/L2525M12		○	○	25	25	170	25	32	25	SNGN1204**	SNGN1207**
CSKNR/L3225P12		○	○	32	25	170	32	32	25	SNGN1204**	SNGN1207**
CSKNR/L3225P15		○	○	32	25	170	32	32	32	SNGN1507**	

● Ex stock ○ On demand

\* With internal cooling

### Spare parts

	Insert	SNGN1204**	SNGN1207**	SNGN1507**
	h	20-32	20-32	32
	Clamp	C1RC	C1RC	C2RC
	Screw (clamp)	CM6×30B (7.0 Nm)	CM6×30B (7.0 Nm)	CM8×30B (10.2 Nm)
	Screw (shim)	SM3×10B	SM3×10B	SM4×12B
	Shim	S12CC-04	S12CC-07	S15CC-07
	Spring	SPR1	SPR1	SPR3
	Wrench (clamp)	WH40L	WH40L	WH50L
	Wrench (shim)	WH20L	WH20L	WH30L

### Insert

	
Cast Iron	PCBN/PCD
A86	A175

System code > A228

Grade selection > A42

Technical info > A501

Cutting data > A366

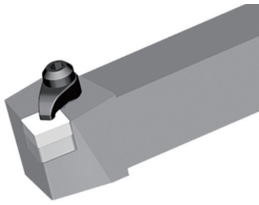

**SN\*\* holder (external) C-Clamping**

CSRRN/L Kr: 75°

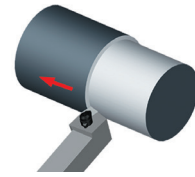
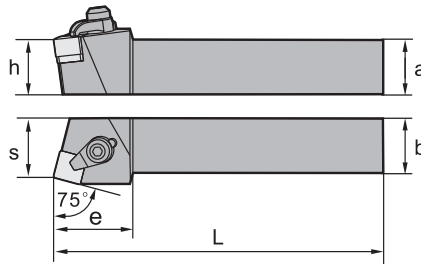

Right hand style









Article	*	Stock		Dimensions [mm]						Inserts	
		R	L	a	b	L	h	s	e		
CSRRN/L2020K12		○	○	20	20	125	20	22	32	SNGN1204**	SNGN1207**
CSRRN/L2525M12		○	○	25	20	100	25	27	32	SNGN1204**	SNGN1207**
CSRRN/L3225P12		○	○	32	25	170	32	27	32	SNGN1204**	SNGN1207**
CSRRN/L3225P15		○		32	25	170	32	32	40	SNGN1507**	
CSRRN/L4040R15		○	○	40	40	200	40	43	40	SNGN1507**	



● Ex stock ○ On demand

\* With internal cooling

Spare parts

	Insert h	SNGN1204** 20-32	SNGN1207** 20-32	SNGN1507** 32-40
 Clamp		C1RC	C1RC	C2RC
 Screw (clamp)		CM6×30B (7.0 Nm)	CM6×30B (7.0 Nm)	CM8×30B (10.2 Nm)
 Screw (shim)		SM3×10B	SM3×10B	SM4×12B
 Shim		S12CC-04	S12CC-07	S15CC-07
 Spring		SPR1	SPR1	SPR3
 Wrench (clamp)		WH40L	WH40L	WH50L
 Wrench (shim)		WH20L	WH20L	WH30L

Insert

	
Cast Iron A86	PCBN/PCD A175

System code > A228

Grade selection > A42



Technical info > A501

Cutting data > A366

## RN\*\* holder (external) C-Clamping

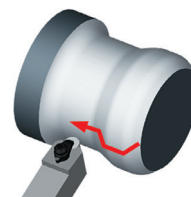
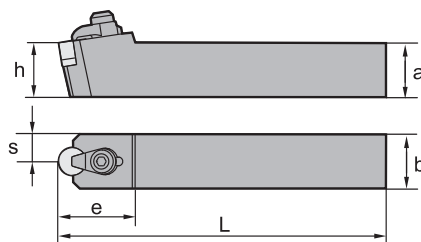
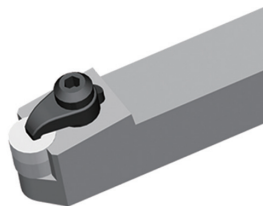
CRDNN









Article	*	Stock	Dimensions [mm]						Inserts	
			a	b	L	h	s	e		
CRDNN2020K12		○	20	20	125	20	10	32	RNGN1204**	RNGN1207**
CRDNN2525M12		○	25	25	150	25	12.5	32	RNGN1204**	RNGN1207**
CRDNN3225P12		○	32	25	170	32	12.5	32	RNGN1204**	RNGN1207**
CRDNN3232P15		○	32	32	170	32	17.5	40	RNGN1507**	
CRDNN4040R15		○	40	40	200	40	20	40	RNGN1507**	

● Ex stock ○ On demand

\* With internal cooling

### Spare parts

	Insert h	RNGN1204**	RNGN1207**	RNGN1507**
		20-32	20-32	32-40
	Clamp	C1RC	C1RC	C2RC
	Screw (clamp)	CM6×30B (7.0 Nm)	CM6×30B (7.0 Nm)	CM8×30B (10.2 Nm)
	Screw (shim)	SM3×10B	SM3×10B	SM4×12B
	Shim	R12CC-04	R12CC-07	R15CC-07
	Spring	SPR1	SPR1	SPR3
	Wrench (clamp)	WH40L	WH40L	WH50L
	Wrench (shim)	WH20L	WH20L	WH30L

### Insert



PCBN/PCD

A174

System code > A228

Grade selection > A42



Technical info > A501

Cutting data > A366

**SN\*\* holder (external) C-Clamping**

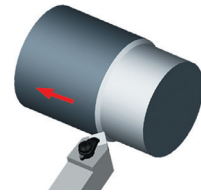
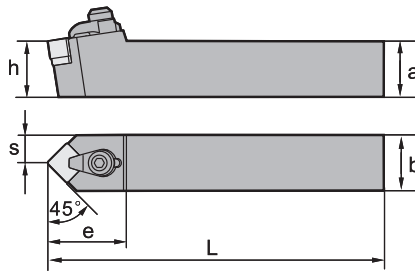
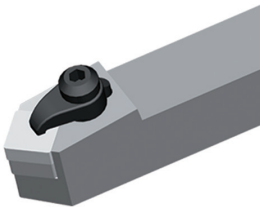
CSDNN Kr: 45°









Article	*	Stock	Dimensions [mm]						Inserts	
			a	b	L	h	s	e		
CSDNN2020K12		○	20	20	125	20	10	35	SNGN1204**	SNGN1207**
CSDNN2525M12		●	25	25	150	25	12.5	30	SNGN1204**	SNGN1207**
CSDNN3225P12		○	32	25	170	32	12.5	35	SNGN1204**	SNGN1207**



● Ex stock ○ On demand

\* With internal cooling

Spare parts

	Insert h	SNGN1204** 20-32	SNGN1207** 20-32
	Clamp	C1RC	C1RC
	Screw (clamp)	CM6×30B (7.0 Nm)	CM6×30B (7.0 Nm)
	Screw (shim)	SM3×10B	SM3×10B
	Shim	S12CC-04	S12CC-07
	Spring	SPR1	SPR1
	Wrench (clamp)	WH40L	WH40L
	Wrench (shim)	WH20L	WH20L

Insert

	
Cast Iron A86	PCBN/PCD A175

System code > A228

Grade selection > A42

Technical info > A501

Cutting data > A366

## CN\*\* holder (external) J-Clamping

JCLNR/L Kr: 95°

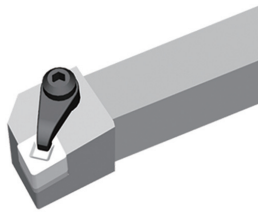

Right hand style

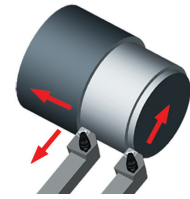
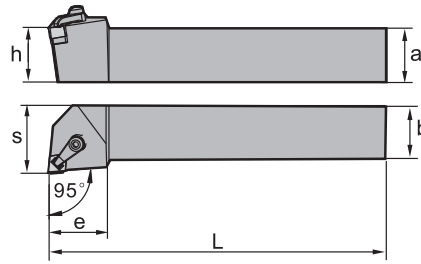

Article	*	Stock		Dimensions [mm]						Inserts
		R	L	a	b	L	h	s	e	
JCLNR/L2020K12	○	○		20	20	125	20	29	32	CNGX1207**
JCLNR/L2525M12	○	○		25	25	150	25	32	32	CNGX1207**

● Ex stock   ○ On demand

\* With internal cooling

### Spare parts

	Insert	CNGX1207**
	<b>h</b>	<b>20-25</b>
	Clamp	C1RJ
	Screw (clamp)	CM6×30B (7.0 Nm)
	Screw (shim)	SM3×10B
	Shim	C12CC-07
	Spring	SPR1
	Wrench (clamp)	WH40L
	Wrench (shim)	WH20L

Insert



Medium Cut

A203

A

Turning

B

Milling

C

Drilling

D

Technical Information

E

Index

System code > A228

Grade selection > A42

Technical info > A501

Cutting data > A366

**DN\*\* holder (external) J-Clamping**

JDJNR/L Kr: 93°

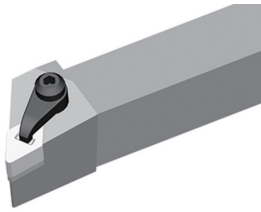

Right hand style

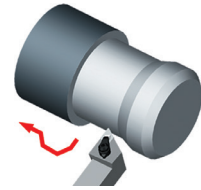
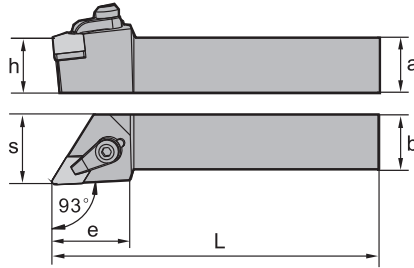







Article	*	Stock		Dimensions [mm]						Inserts
		R	L	a	b	L	h	s	e	
JDJNR/L2525M15	●	○		25	25	150	25	32	38	DNGX1507**
JDJNR/L3225P15	○	○		32	25	170	32	32	38	DNGX1507**

● Ex stock ○ On demand

\* With internal cooling

Spare parts

	Insert	DNGX1507**
	<b>h</b>	<b>25-32</b>
	Clamp	C1RJ
	Screw (clamp)	CM6×30B (7.0 Nm)
	Screw (shim)	SM3×10B
	Shim	D15CC-07
	Spring	SPR1
	Wrench (clamp)	WH40L
	Wrench (shim)	WH20L

Insert



Medium Cut

A206

System code > A228

Grade selection > A42

Technical info > A501

Cutting data > A366

**A**

## SN\*\* holder (external) J-Clamping

JSDNN Kr: 45°

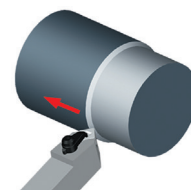
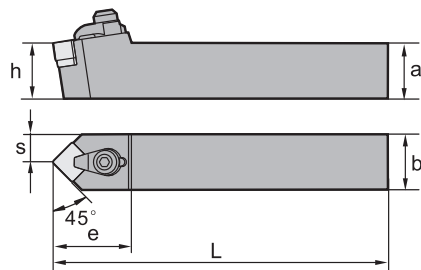
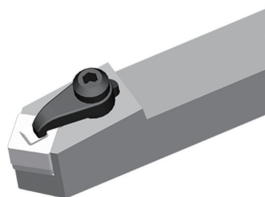

Turning

**B**

Article	*	Stock	Dimensions [mm]						Inserts
			a	b	L	h	s	e	
JSDNN2525M12	○	○	25	25	150	25	12.5	40	SNGX1207**
JSDNN3225P12	○	○	32	25	170	32	12.5	40	SNGX1207**

Milling

● Ex stock ○ On demand

\* With internal cooling

**C**

Spare parts		
	Insert	SNGX1207**
	h	20-32
	Clamp	C1RJ
	Screw (clamp)	CM6×30B (7.0 Nm)
	Screw (shim)	SM3×10B
	Shim	S12CC-07
	Spring	SPR1
	Wrench (clamp)	WH40L
	Wrench (shim)	WH20L

Drilling

**D**

Insert
<b>Medium Cut</b>
A216

Technical Information

**E**

Index

System code > A228

Grade selection > A42

Technical info > A501

Cutting data > A366





**S C L N L 25 25 M 12 – S C**

1 2 3 4 5 6 7 8 9 10 11

**A**

Turning

**B**

Milling

**C**

Drilling

**D**







Technical Information

**E**























Index

Clamping system	
Code	Description
S	Knee lever clamping 







1

Insert shape	
C	
D	
R	
S	
T	
V	
W	

2

Tool holder type and entering angle				
 A	 B	 C	 D	 E
 F	 G	 H	 J	 K
 L	 M	 N	 O	 P
 Q	 R	 S	 T	 U
 V	 W	 X		

3

Clearance angle	
 B	 C
 D	 E
 N	 P

4

Cutting direction	
<b>5</b>	

Shank height h [mm]	
Code	h
12	12
16	16
20	20
25	25
32	32
40	40
50	50
<b>6</b>	

Shank width b [mm]	
Code	b
12	12
16	16
20	20
25	25
32	32
40	40
50	50
<b>7</b>	

Holder length L [mm]	
Code	L
H	100
K	125
M	150
P	170
Q	180
R	200
S	250
T	300
<b>8</b>	

Cutting edge length l [mm]								
I.C [mm]	Insert shape							
	C	D	R	S	T	V	W	
5,56	09							
6,35	06	07					11	
9,525	09	11	09	09	16	16	06	
12,7	12	15	12	12	22	22	08	
15,875	16	19	15	15	27			
19,05	19		19	19	33			
25,4	25		25	25	44			
32	32							
<b>9</b>								

<b>Swissturning</b>
<b>10</b>

<b>With inner cooling</b>
<b>11</b>

**A**

Turning

**B**

Milling

**C**

Drilling

**D**

Technical Information

**E**

Index

## CC\*\* holder S-Clamping

SCACR/L-SC Kr: 90°

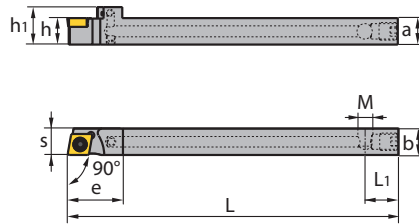
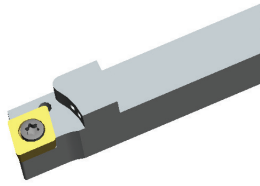

Article	*	Stock		Dimensions [mm]									kg	Inserts
		R	L	a	b	L	h	h <sub>1</sub>	s	L <sub>1</sub>	e	M		
SCACR/L1212M09-SC	*	●	●	12	12	150	12	17	12	15	25	M8X1	0.14	CC**09T3**
SCACR/L1616H09-SC	*	●	●	16	16	100	16	21	16	15	28	M8X1	0.21	CC**09T3**

● Ex stock ○ On demand

\* With internal cooling

### Spare parts

	Insert	CC**09T3**
	<b>h</b>	<b>12-16</b>
	Screw	I60M3.5x8 (2.7 Nm)
	Wrench	WT15IP

### Insert

<b>Finishing</b>	<b>Medium Cut</b>	<b>Roughing</b>	<b>Alum Machining</b>	<b>Cast Iron</b>	<b>PCBN/PCD</b>
A117	A119	A121	A122	A121	A180

System code > A304

Grade selection > A42

Technical info > A501

Cutting data > A366

A

Turning

B

Milling

C

Drilling

D

Technical Information

E

Index

## CC\*\* holder S-Clamping

SCLCR/L-SC Kr: 95°

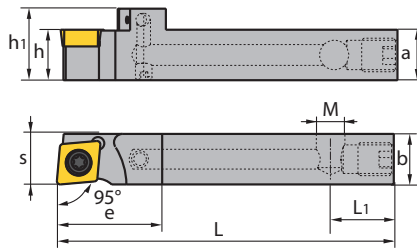
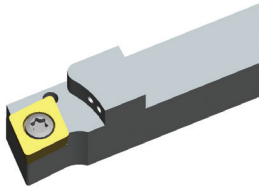

Article	*	Stock		Dimensions [mm]								kg	Inserts
		R	L	a	b	L	h	h <sub>1</sub>	s	L <sub>1</sub>	e		
SCLCR/L1010F06-S	•	•	10	10	80	10	15	10	15	10		0.06	CC**0602**
SCLCR/L1212F09-SC	*	•	12	12	80	12	17	12	15	25	M8X1	0.07	CC**09T3**

• Ex stock    ○ On demand

\* With internal cooling

### Spare parts

	Insert	CC**0602**	CC**09T3**
	<b>h</b>	<b>10</b>	<b>12</b>
	Screw	I60M2.5×6.5 (1.0 Nm)	I60M3.5×8 (2.7 Nm)
	Wrench	WT07IP	WT15IP

### Insert

<b>Finishing</b>	<b>Medium Cut</b>	<b>Roughing</b>	<b>Alum Machining</b>	<b>Cast Iron</b>	<b>PCBN/PCD</b>
A116	A119	A121	A122	A121	A180

### DC\*\* holder S-Clamping

SDACR/L-SC Kr: 90°

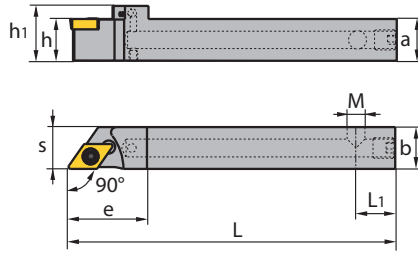
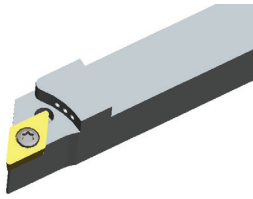

Article	*	Stock		Dimensions [mm]									kg	Inserts
		R	L	a	b	L	h	h <sub>1</sub>	s	L <sub>1</sub>	e	M		
SDACR/L1212M07-SC	*	●	●	12	12	150	12	17	12	15	25	M8X1	0.15	DC**0702**
SDACR/L1212H11-SC	*	○		12	12	100	12	17	12	15	30	M8X1	0.1	DC**11T3**
SDACR/L1616K11-SC	*	●	●	16	16	125	16	21	16	15	30	M8X1	0.21	DC**11T3**
SDACR/L1212M11-SC	*	●	●	12	12	150	12	17	12	15	30	M8X1	0.14	DC**11T3**

● Ex stock ○ On demand

\* With internal cooling

#### Spare parts

	Insert	DC**0702**	DC**11T3**	DC**11T3**
		h	12-16	12
	Screw	I60M2.5×6.5 (1.0 Nm)	I60M3.5×8 (2.7 Nm)	I60M3.5×8 (2.7 Nm)
	Wrench	WT07IP	WT15IP	WT15IP

#### Insert

Finishing	Medium Cut	Roughing	Alum Machining	Cast Iron	PCBN/PCD
A126	A127	A129	A129	A129	A184

System code > A304

Grade selection > A42

Technical info > A501

Cutting data > A366

DC\*\* holder S-Clamping

SDHCR/L-SC Kr: 107°30'

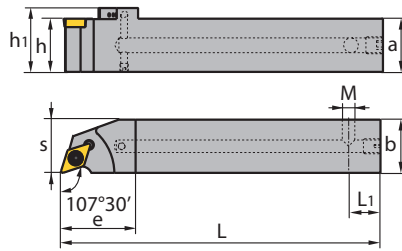
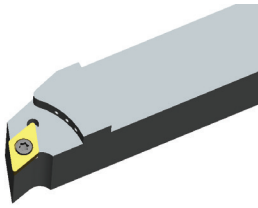

Article	*	Stock	Dimensions [mm]										kg	Inserts
			a	b	L	h	h <sub>1</sub>	s	L <sub>1</sub>	e	M			
SDHCR/L2020K11-SC	*	○	20	20	125	20	25	20	15	30	M8X1	0.35	DC**11T3**	
SDHCR/L2525M11-SC	*	●	25	25	150	25	30	25	15	35	M8X1	0.66	DC**11T3**	

● Ex stock ○ On demand

\* With internal cooling

Spare parts

	Insert	DC**11T3**
	h	20-25
	Screw	I60M3.5x8 (2.7 Nm)
	Wrench	WT15IP

Insert

Finishing	Medium Cut	Roughing	Alum Machining	Cast Iron	PCBN/PCD
A126	A127	A129	A129	A129	A184

### DC\*\* holder S-Clamping

SDJCR/L-SC Kr: 93°

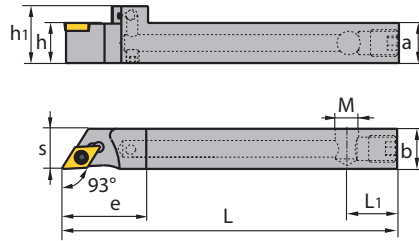
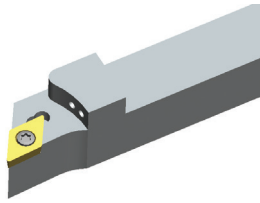

Article	*	Stock		Dimensions [mm]									kg	Inserts
		R	L	a	b	L	h	h <sub>1</sub>	s	L <sub>1</sub>	e	M		
SDJCR/L1212H07-SC	*	●	●	12	12	100	12	17	12	15	25	M8X1	0.1	DC**0702**
SDJCR/L1212H11-SC	*	●	●	12	12	100	12	17	12	15	30	M8X1	0.1	DC**11T3**
SDJCR/L1616K11-SC	*	●	●	16	16	125	16	21	16	15	30	M8X1	0.21	DC**11T3**

● Ex stock ○ On demand

\* With internal cooling

#### Spare parts

	Insert	DC**0702**	DC**11T3**
	<b>h</b>	<b>12</b>	<b>12-16</b>
	Screw	I60M2.5×6.5 (1.0 Nm)	I60M3.5×8 (2.7 Nm)
	Wrench	WT07IP	WT15IP

#### Insert

<b>Finishing</b>	<b>Medium Cut</b>	<b>Roughing</b>	<b>Alum Machining</b>	<b>Cast Iron</b>	<b>PCBN/PCD</b>
A126	A127	A129	A129	A129	A184

System code > A304

Grade selection > A42

Technical info > A501

Cutting data > A366

DC\*\* holder S-Clamping

SDNCN-SC Kr: 62°30'

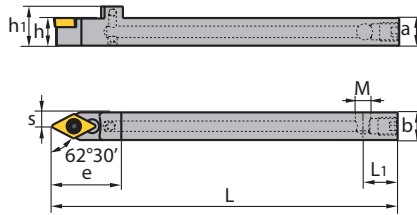
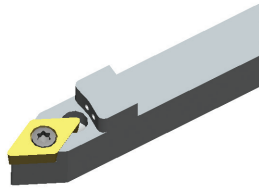

Article	*	Stock	Dimensions [mm]										kg	Inserts
			a	b	L	h	h <sub>1</sub>	s	L <sub>1</sub>	e	M			
SDNCN1212H11-SC	*	○	12	12	100	12	17	6	15	30	M8X1	0.09	DC**11T3**	
SDNCN1212M11-SC	*	●	12	12	150	12	17	6	15	30	M8X1	0.1	DC**11T3**	

● Ex stock ○ On demand

\* With internal cooling

Spare parts

	Insert	DC**11T3**
	h	12
	Screw	I60M3.5x8 (2.7 Nm)
	Wrench	WT15IP

Insert

Finishing	Medium Cut	Roughing	Alum Machining	Cast Iron	PCBN/PCD
A126	A127	A129	A129	A129	A184



A

VC\*\* holder **S-Clamping**

SVACR/L-SC Kr: 90°

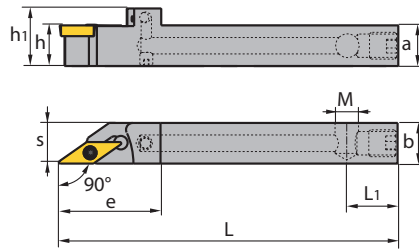
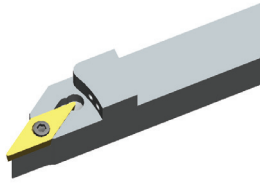

Turning

B

Article	*	Stock		Dimensions [mm]									kg	Inserts
		R	L	a	b	L	h	h <sub>1</sub>	s	L <sub>1</sub>	e	M		
SVACR/L1212H11-SC	*	●	●	12	12	100	12	17	12	15	30	M8X1	0.1	VC**1103**

Milling

- Ex stock ○ On demand
- \* With internal cooling

C

Spare parts		
	<b>Insert</b>	<b>VC**1103**</b>
	<b>h</b>	<b>12</b>
	Screw	I60M2.5×6.5 (1.0 Nm)
	Wrench	WT07IP

Drilling

Insert		
<b>Finishing</b>	<b>Alum Machining</b>	<b>PCBN/PCD</b>
A156	A154	A193

D

Technical Information

E

Index

System code > A304

Grade selection > A42

Technical info > A501

Cutting data > A366

## VC\*\* holder S-Clamping

SVJCR/L-SC Kr: 93°

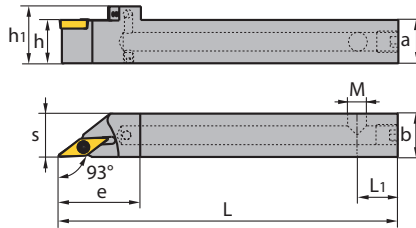
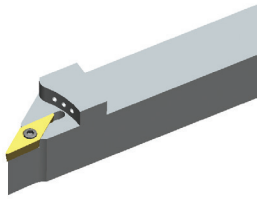

Article	*	Stock		Dimensions [mm]									kg	Inserts
		R	L	a	b	L	h	h <sub>1</sub>	s	L <sub>1</sub>	e	M		
SVJCR/L0808H11-S	●	●	8	8	100	8	13	8	15	22	M8X1	0.044	VC**1103**	
SVJCR/L1212H11-SC	*	●	12	12	100	12	17	12	15	30	M8X1	0.095	VC**1103**	
SVJCR/L1616K11-SC	*	●	16	16	125	16	21	16	15	30	M8X1	0.2	VC**1103**	

● Ex stock ○ On demand

\* With internal cooling

### Spare parts

Insert	VC**1103**
<b>h</b>	<b>8-16</b>
Screw	I60M2.5x6.5 (1.0 Nm)
Wrench	WT07IP

### Insert

Finishing	Alum Machining	PCBN/PCD
A156	A154	A193

**RW P L F N L/R 19**

**1 2 3 4 5 6 7**

**A**

Turning

**B**

Milling

**C**







Drilling















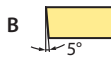
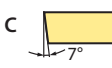

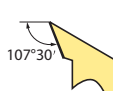

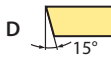





**D**

Technical Information

**E**

Index

<p>(RW = Rail Way)</p> <p><b>Tool holders for rail applications</b></p>	Clamping system		Insert shape
	Code	Description	
	P	Lever lock clamping	
	M	Wedge/pin lock clamping	
	S	Screw-on clamping	
	C/J	Wedge clamping	
	D	Duel wedge clamping	
			
<b>1</b>	<b>2</b>		<b>3</b>

Tool holder type and entering angle					Clearance angle	
						
<b>A</b>	<b>B</b>	<b>C</b>	<b>D</b>	<b>E</b>	<b>B</b>	<b>C</b>
						
<b>F</b>	<b>G</b>	<b>H</b>	<b>J</b>	<b>K</b>	<b>D</b>	<b>E</b>
						
<b>L</b>	<b>M</b>	<b>N</b>	<b>O</b>	<b>P</b>	<b>N</b>	<b>P</b>
						
<b>Q</b>	<b>R</b>	<b>S</b>	<b>T</b>	<b>U</b>		
						
<b>V</b>	<b>W</b>	<b>X</b>				
<b>4</b>					<b>5</b>	

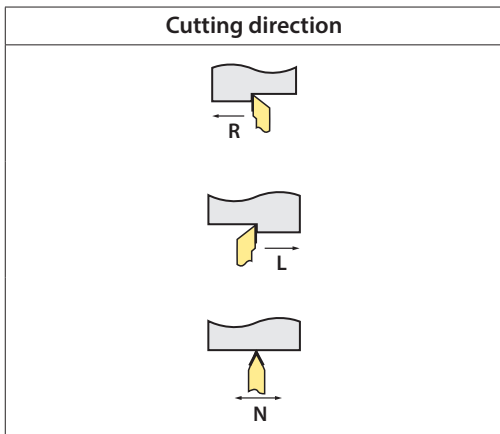

**6**

**Cutting edge length l [mm]**

I.C [mm]	Insert shape						
	C	D	R	S	T	V	W
5,56					<b>09</b>		
6,35	<b>06</b>	<b>07</b>			<b>11</b>		
9,525	<b>09</b>	<b>11</b>	<b>09</b>	<b>09</b>	<b>16</b>	<b>16</b>	<b>06</b>
12,7	<b>12</b>	<b>15</b>	<b>12</b>	<b>12</b>	<b>22</b>	<b>22</b>	<b>08</b>
15,875	<b>16</b>	<b>19</b>	<b>15</b>	<b>15</b>	<b>27</b>		
19,05	<b>19</b>		<b>19</b>	<b>19</b>	<b>33</b>		
25,4	<b>25</b>		<b>25</b>	<b>25</b>	<b>44</b>		
32			<b>32</b>				

**7**

**A**

Turning

**B**

Milling

**C**

Drilling

**D**

Technical Information

**E**

Index

A

## LN\*\* holder (external) P-Clamping

RW-PLANR/L Kr: 90°

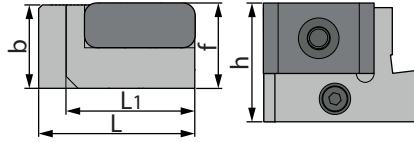

Right hand style

Turning

B

Article	*	Stock		Dimensions [mm]					Inserts
		R	L	b	L	h	L <sub>1</sub>	f	
RW-PLANR/L-19	*	○	○	22.5	43	32	35	23	LNUX1919**
RW-PLANR/L-30	*	○	○	22.5	43	32	35	23	LNUX3019**

Milling

● Ex stock ○ On demand

\* With internal cooling

C

### Spare parts

	Insert	LNUX1919**	LNUX3019**
	<b>h</b>	<b>25-32</b>	<b>25-32</b>
	Knee lever	L5 RWL	L5 RWL
	Screw	LEM8×25 RWL (10.2 Nm)	LEM8×25 RWL (10.2 Nm)
	Wrench	WH30L	WH30L

Drilling

D

### Insert



Heavy Turning

A115

Technical Information

E

Index

System code > A314

Grade selection > A42

Technical info > A501

Cutting data > A366

## LN\*\* holder (external) P-Clamping

RW-PLFNR/L Kr: 90°



Right hand style

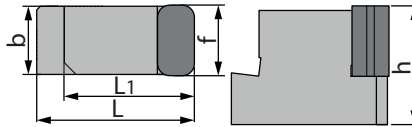



Article	*	Stock		Dimensions [mm]					Inserts
		R	L	b	L	h	L <sub>1</sub>	f	
RW-PLFNR/L-19	*	○	○	18.6	43	32	35	19.1	LNUX1919**

● Ex stock ○ On demand

\* With internal cooling

### Spare parts

	Insert	LNUX1919**
	h	25-32
	Knee lever	L5 RWL
	Screw	LEM8×25 RWL (10.2 Nm)
	Wrench	WH30L

### Insert



**Heavy Turning**  
A115

**A**

Turning

## CN\*\* holder (external) P-Clamping

RW-PCLNR/L Kr: 95°

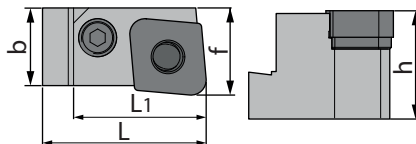

Right hand style

**B**

Milling

Article	*	Stock		Dimensions [mm]					Inserts
		R	L	b	L	h	L <sub>1</sub>	f	
RW-PCLNR/L-1907	*	○	○	24.8	43	32	35	19.1	CNMM1907**
RW-PCLNR/L-1911	*	○	○	24.8	43	32	35	19.1	CNMM1911**

● Ex stock ○ On demand

\* With internal cooling

**C**

Drilling

Spare parts			
	Insert	CNMM1907**	CNMM1911**
	h	25-32	25-32
	Knee lever	L5 RWC	L5 RWC
	Screw	LEM8×25 RWC (10.2 Nm)	LEM8×25 RWC (10.2 Nm)
	Shim pin (shim)	SP5 RWC	SP5 RWC
	Shim	C19 RWC	C19 RWC
	Wrench	WH30L	WH30L

**D**

Technical Information

Insert	
<b>Finishing</b>	<b>Roughing</b>
A114	A114

**E**

Index

System code > A314

Grade selection > A42

Technical info > A501

Cutting data > A366

## Notes

A series of horizontal dotted lines for taking notes.

**A**  
Turning

**B**  
Milling











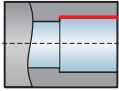
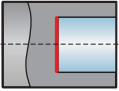
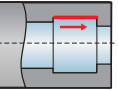
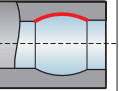
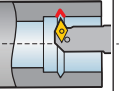
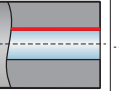
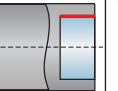









































**C**  
Drilling

**D**  
Technical Information

**E**  
Index











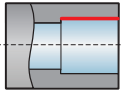
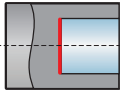
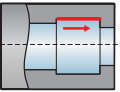
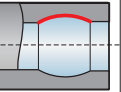
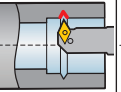
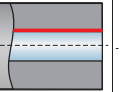
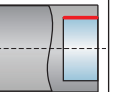



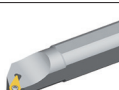

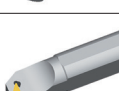
### Boring bars

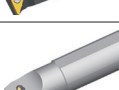
Boring bar	Application					Workpiece		Page	
	Longitudinal turning	Facing	Undercut	Contouring	Profiling	Stable	Unstable		
									
<b>P</b>	PDSNR/L 62°30'							A326	
	PCLNR/L 95°								A324
	PDUNR/L 93°								A327
	PSKNR/L 75°								A329
	PTFNR/L 91°								A330
	PWLNR/L 95°								A332
<b>S</b>	SCFCR/L 90°								A352
	SCLCR/L 95°								A352
	SCLPR/L 95°								A354
	SDQCR/L 107°30'								A357
	SDQPR/L 107°30'								A356
	SDUCR/L 93°								A359
	SDUPR/L 93°								A358
	SDZCR/L 95°								A338

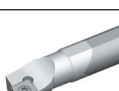
 Recommended

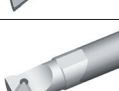
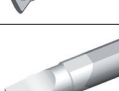
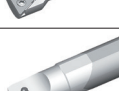
## Boring bars

Boring bar	Application					Workpiece		Page
	Longitudinal turning	Facing	Undercut	Contouring	Profiling	Stable	Unstable	
								
<b>S</b>	SSKCR/L 75° 	<input checked="" type="checkbox"/>					<input checked="" type="checkbox"/>	A339
	STFCR/L 91° 	<input checked="" type="checkbox"/>						A361
	STUPR/L 93° 	<input checked="" type="checkbox"/>						A360
	SVQBR/L 107°30' 	<input checked="" type="checkbox"/>			<input checked="" type="checkbox"/>	<input checked="" type="checkbox"/>		A345
	SVXBR/L 93° 			<input checked="" type="checkbox"/>			<input checked="" type="checkbox"/>	A347
	SVQCR/L 107°30' 	<input checked="" type="checkbox"/>						A363
	SVUBR/L 93° 	<input checked="" type="checkbox"/>			<input checked="" type="checkbox"/>	<input checked="" type="checkbox"/>		A346
	SVUCR/L 93° 	<input checked="" type="checkbox"/>			<input checked="" type="checkbox"/>	<input checked="" type="checkbox"/>		A364
	SZLNR/L 95° 	<input checked="" type="checkbox"/>	<input checked="" type="checkbox"/>				<input checked="" type="checkbox"/>	A365
<b>Antivibration</b>	SCLPR/L 95° 	<input checked="" type="checkbox"/>	<input checked="" type="checkbox"/>					A348
	SDQPR/L 107°30' 	<input checked="" type="checkbox"/>			<input checked="" type="checkbox"/>	<input checked="" type="checkbox"/>		A349
	SDUPR/L 93° 	<input checked="" type="checkbox"/>						A350
	STUPR/L 93° 	<input checked="" type="checkbox"/>						A351
	SVQCR/L 107°30' 	<input checked="" type="checkbox"/>			<input checked="" type="checkbox"/>	<input checked="" type="checkbox"/>		A343
	SVUCR/L 93° 	<input checked="" type="checkbox"/>			<input checked="" type="checkbox"/>	<input checked="" type="checkbox"/>		A344

 Recommended

## S 16 R – S D U C R 07 – KR93

1

2

3

4

5

6

7

8

9

10

A

Turning

B

Milling

C

Drilling

D

Technical Information

E

Index

### Shank type

Code	Description
A	Steel shank (IC)
C	Solid carbide shank
E	Solid carbide shank (IC)
S	Steel shank
X	Special application

1

### Shank diameter d [mm]

Code	d
16	16
20	20
25	25
32	32
40	40
50	50



2

### Clamping system

Code	L
H	100
K	125
M	150
N	160
P	170
Q	180
R	200
S	250
T	300
U	350
V	400







3

### Clamping system

Code	Description
P	Knee lever clamping 
S	Screw clamping 

4

### Insert shape

C		D	
R		S	
T		V	
W			

5

**Tool holder type and entering angle**

**6**

**Clearance angle**

**7**

**Cutting direction**

**8**

**Cutting edge length l [mm]**

I.C [mm]	Insert shape						
	C	D	R	S	T	V	W
5,56	09						
6,35	06	07			11		
9,525	09	11	09	09	16	16	06
12,7	12	15	12	12	22	22	08
15,875	16	19	15	15	27		
19,05	19		19	19	33		
25,4	25		25	25	44		
32			32				

**9**

**Entering angle**

**10**

**A**

Turning

**B**

Milling

**C**

Drilling

**D**

Technical Information

**E**

Index

## CN\*\* steel boring bar P-Clamping

PCLNR/L Kr: 95°

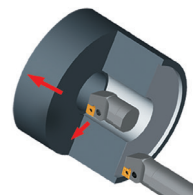
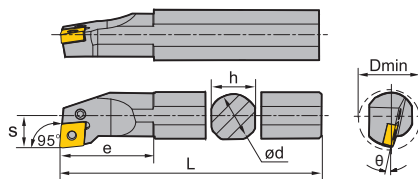
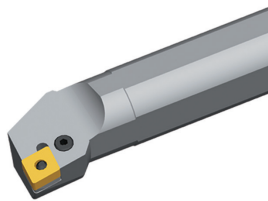

Right hand style









Article	*	Stock		Dimensions [mm]							Inserts
		R	L	ød	L	h	S	e	D <sub>min</sub>	θ	
S16M-PCLNR/L09		●	●	16	150	15	11	28	20	-12	CN**0903**
S16R-PCLNR/L09		●	●	16	200	15	11	28	20	-12	CN**0903**
S20Q-PCLNR/L09		●	●	20	180	18	13	31	25	-11	CN**0903**
S20S-PCLNR/L09		●	●	20	250	18	13	31	25	-11	CN**0903**
S25Q-PCLNR/L09		○	○	25	180	23	17	35	32	-10	CN**0903**
S25T-PCLNR/L09		●	○	25	300	23	17	35	32	-10	CN**0903**
A16M-PCLNR/L09	*	○	○	16	150	14	11		20	-12	CN**0903**
S25Q-PCLNR/L12		○	○	25	180	23	17	40	32	-12	CN**1204**
S25T-PCLNR/L12		●	●	25	300	23	17	40	32	-12	CN**1204**
S32R-PCLNR/L12		●	●	32	200	30	22	50	44	-10	CN**1204**
S32U-PCLNR/L12		●	●	32	350	30	22	50	44	-10	CN**1204**
S40S-PCLNR/L12		○	●	40	250	37	27	55	54	-10	CN**1204**
S40V-PCLNR/L12		●	●	40	400	37	27	55	54	-10	CN**1204**
S50S-PCLNR/L12		○	○	50	250	47	35	56	63	-10	CN**1204**
S50W-PCLNR/L12		●	●	50	450	47	35	56	63	-10	CN**1204**
A25R-PCLNR/L12	*	●	●	25	200	24	17	40	32	-12	CN**1204**
A32S-PCLNR/L12	*	●	●	32	250	31	22	50	44	-10	CN**1204**
S50S-PCLNR/L19		○	○	50	250	47	35	63	63	-10	CN**1906**
S50W-PCLNR/L19		●	○	50	450	47	35	63	63	-10	CN**1906**

● Ex stock ○ On demand

\* With internal cooling

**CN\*\* steel boring bar**

Spare parts

	Insert ød	CN**0903** 16-25	CN**1204** 25	CN**1204** 32-50	CN**1906** 50
	Knee lever	L3C	L4A	L4A	L6
	Screw	LEM5×9B (4.0 Nm)			
	Screw				LEM10×27 (16.6 Nm)
	Screw		LEM6×13.4A (7.0 Nm)	LEM6×13.4A (7.0 Nm)	
	Shim pin (shim)			SP4	SP6
	Shim				C19AP
	Shim			C12APB	
	Wrench		WH25L	WH25L	WH40L
	Wrench	WT09IP			

Insert

					
<b>Wiper</b> A51	<b>Finishing</b> A52	<b>Medium Cut</b> A53	<b>Roughing</b> A57	<b>Cast Iron</b> A61	<b>PCBN/PCD</b> A177

System code > A322

Grade selection > A42

Technical info > A501

Cutting data > A366

## DN\*\* steel boring bar P-Clamping

PDSNR/L Kr: 62°30'

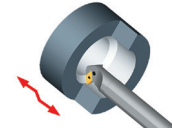
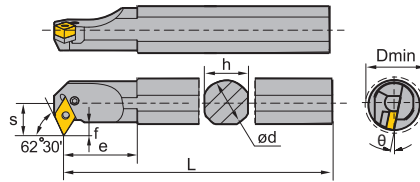
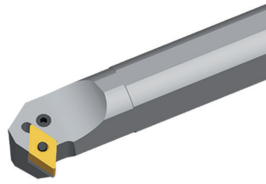

Right hand style

Article	*	Stock		Dimensions [mm]								Inserts
		R	L	ød	L	h	s	e	f	D <sub>min</sub>	θ	
S32R-PDSNR/L15-3		○	○	32	200	30	22	45	8.5	40	-11	DN**1504**
S40V-PDSNR/L15-3		●		40	400	37	27	43	9.4	50	-11	DN**1504**
A32S-PDSNR/L15-3	*	○	○	32	250	31	22	45	8.5	40	-11	DN**1504**
S32R-PDSNR/L15		●	●	32	200	30	22	45	8.5	40	-11	DN**1506**
S32U-PDSNR/L15		●	●	32	350	30	22	45	8.5	40	-11	DN**1506**
S40S-PDSNR/L15		○	○	40	250	37	27	43	9.4	50	-11	DN**1506**
S40V-PDSNR/L15		○	○	40	400	37	27	43	9.4	50	-11	DN**1506**
A32S-PDSNR/L15	*	●	●	32	250	31	22	45	8.5	40	-11	DN**1506**

● Ex stock ○ On demand

\* With internal cooling

### Spare parts

	Insert ød	DN**1504**	DN**1506**
		32-40	32-40
	Knee lever	L4	L4B
	Screw	LEM8×21 (10.2 Nm)	LEM8×21 (10.2 Nm)
	Shim pin (shim)	SP4	SP4
	Shim	D15AP	D15AP
	Wrench	WH30L	WH30L

### Insert

Wiper A62	Finishing A63	Medium Cut A63	Roughing A68	Cast Iron A69	PCBN/PCD A178

System code > A322

Grade selection > A42

Technical info > A501

Cutting data > A366

**DN\*\* steel boring bar P-Clamping**

PDUNR/L Kr: 93°

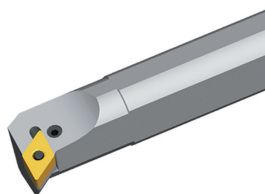

Right hand style

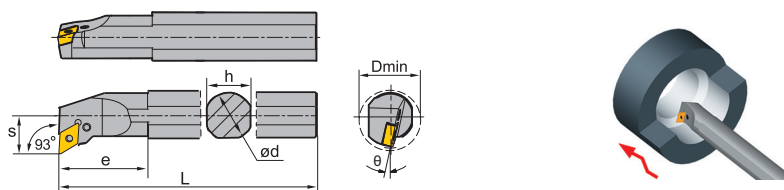

Article	*	Stock		Dimensions [mm]							Inserts
		R	L	ød	L	h	s	e	D <sub>min</sub>	θ	
S20Q-PDUNR/L11	● ○	20	180	18	13	30	25	-16	DN**1104**		
S20S-PDUNR/L11	● ●	20	250	18	13	30	25	-16	DN**1104**		
S25Q-PDUNR/L11	● ●	25	180	23	17	35	32	-13	DN**1104**		
S25T-PDUNR/L11	● ●	25	300	23	17	35	32	-13	DN**1104**		
S32R-PDUNR/L11	○ ○	32	200	30	22	40	40	-16	DN**1104**		
S32U-PDUNR/L11	● ●	32	350	30	22	40	40	-16	DN**1104**		
A25R-PDUNR/L11	* ●	25	200	24	17	35	32	-13	DN**1104**		
S32R-PDUNR/L15-3	○ ○	32	200	30	22	50	40	-16	DN**1504**		
S32U-PDUNR/L15-3	● ●	32	350	30	22	50	40	-16	DN**1504**		
S40S-PDUNR/L15-3	○ ○	40	250	37	27	50	50	-11	DN**1504**		
S40V-PDUNR/L15-3	● ●	40	400	37	27	50	50	-11	DN**1504**		
A32S-PDUNR/L15-3	* ● ●	32	250	31	22	50	40	-16	DN**1504**		
S32R-PDUNR/L15	○ ○	32	200	30	22	50	40	-16	DN**1506**		
S32U-PDUNR/L15	● ●	32	350	30	22	50	40	-16	DN**1506**		
S40S-PDUNR/L15	○ ○	40	250	37	27	50	50	-11	DN**1506**		
S40V-PDUNR/L15	● ●	40	400	37	27	50	50	-11	DN**1506**		
A32S-PDUNR/L15	* ● ●	32	250	31	22	50	40	-16	DN**1506**		

● Ex stock ○ On demand

\* With internal cooling

Spare parts

	Insert ød	DN**1104** 20-25	DN**1104** 32	DN**1504** 32-40	DN**1506** 32-40
	Knee lever	L3D	L3	L4	L4B
	Screw	LEM5×12B (4.0 Nm)	LEM6×17 (7.0 Nm)	LEM8×21 (10.2 Nm)	LEM8×21 (10.2 Nm)
	Screw			LEM8×21 (10.2 Nm)	LEM8×21 (10.2 Nm)
	Shim pin (shim)		SP3	SP4	SP4
	Shim		D11AP	D15AP	D15AP
	Wrench		WH25L	WH30L	WH30L
	Wrench	WT09IP			

System code > A322

Grade selection > A42

Technical info > A501

Cutting data > A366



A

Turning

B

Milling

C

Drilling

D

Technical Information

E

Index



**A**

## DN\*\* steel boring bar

Insert



Wiper

A62



Finishing

A63



Medium Cut

A63



Roughing

A68



Cast Iron

A69



PCBN/PCD

A178

Turning

**B**

Milling

**C**

Drilling

**D**

Technical  
Information

**E**

Index

System code > A322

Grade selection > A42

Technical info > A501

Cutting data > A366

SN\*\* steel boring bar **P-Clamping**

PSKNR/L Kr: 75°

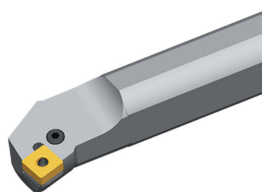

Right hand style

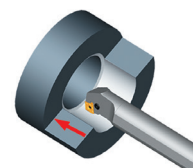
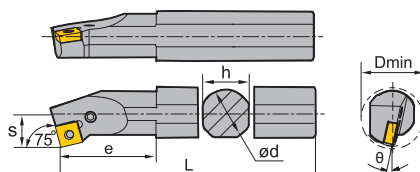

Article	*	Stock		Dimensions [mm]							Inserts
		R	L	ød	L	h	s	e	D <sub>min</sub>	θ	
S25Q-PSKNR/L12		○	●	25	180	23	17	42	32	-12	SN**1204**
S25T-PSKNR/L12		●	○	25	300	23	17	42	32	-12	SN**1204**
S32R-PSKNR/L12		○	○	32	200	30	22	45	44	-10	SN**1204**
S32U-PSKNR/L12		●	●	32	350	30	22	45	44	-10	SN**1204**
S40S-PSKNR/L12		○	○	40	250	37	27	50	54	-10	SN**1204**
S40V-PSKNR/L12		●	○	40	400	37	27	50	54	-10	SN**1204**
A25R-PSKNR/L12	*	●	●	25	200	24	17	42	32	-12	SN**1204**
A32S-PSKNR/L12	*	●	●	32	250	31	22	50	44	-12	SN**1204**

● Ex stock ○ On demand

\* With internal cooling

Spare parts			
	Insert ød	SN**1204**	SN**1204**
		25	32-40
	Knee lever	L4A	L4
	Screw		LEM8×21 (10.2 Nm)
	Screw	LEM6×13.4A (7.0 Nm)	
	Shim pin (shim)		SP4
	Shim		S12APB
	Wrench	WH25L	WH30L

Insert				
Finishing A73	Medium Cut A73	Roughing A78	Cast Iron A84	PCBN/PCD A162

System code > A322

Grade selection > A42

Technical info > A501

Cutting data > A366

## TN\*\* steel boring bar P-Clamping

PTFNR/L Kr: 90°

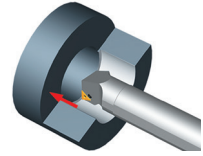
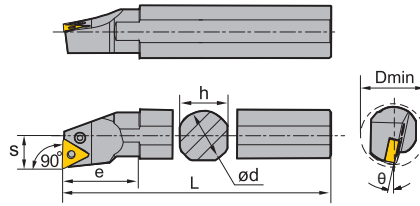
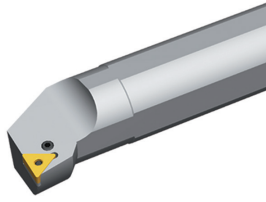

Right hand style

Article	*	Stock		Dimensions [mm]							Inserts
		R	L	ød	L	h	s	e	D <sub>min</sub>	θ	
S16M-PTFNR/L11	○	○	16	150	15	11	28	20	-14	TN**1103**	
S16R-PTFNR/L11	●	●	16	200	15	11	28	20	-14	TN**1103**	
S20Q-PTFNR/L11	●	●	20	180	18	13	31	25	-12	TN**1103**	
S20S-PTFNR/L11	●	●	20	250	18	13	31	25	-12	TN**1103**	
S25Q-PTFNR/L11	○	○	25	180	23	17	35	32	-10	TN**1103**	
S25T-PTFNR/L11	○	○	25	300	23	17	35	32	-10	TN**1103**	
S25Q-PTFNR/L16	○	○	25	180	23	17	42	32	-12	TN**1604**	
S25T-PTFNR/L16	●	●	25	300	23	17	42	32	-12	TN**1604**	
S32R-PTFNR/L16	○	○	32	200	30	22	50	44	-10	TN**1604**	
S32U-PTFNR/L16	●	●	32	350	30	22	50	44	-10	TN**1604**	
S40S-PTFNR/L16	○	○	40	250	37	27	55	54	-10	TN**1604**	
S40V-PTFNR/L16	●	●	40	400	37	27	55	54	-10	TN**1604**	
A25R-PTFNR/L16	*	○	25	200	24	17	40	32	-12	TN**1604**	
A32S-PTFNR/L16	*	●	32	250	31	22	50	44	-10	TN**1604**	

● Ex stock ○ On demand

\* With internal cooling

### Spare parts

Insert	ød	TN**1103**	TN**1604**	TN**1604**
		16-25	25	32-40
Knee lever		L2	L3B	L3
Screw		LEM5×9B (4.0 Nm)	LEM5×12B (4.0 Nm)	LEM6×17 (7.0 Nm)
Shim pin (shim)				SP3
Shim				T16APB
Wrench			WH20L	WH25L
Wrench		WT09IP		







System code > A322

Grade selection > A42

Technical info > A501

Cutting data > A366

**TN\*\* steel boring bar**

Insert					
					
<b>Wiper</b>	<b>Finishing</b>	<b>Medium Cut</b>	<b>Roughing</b>	<b>Cast Iron</b>	<b>PCBN/PCD</b>
A87	A88	A90	A92	A99	A163

**A**

Turning

**B**

Milling

**C**

Drilling

**D**

Technical Information

**E**

Index

System code > A322

Grade selection > A42

Technical info > A501

Cutting data > A366



## WN\*\* steel boring bar P-Clamping

PWLNR/L Kr: 95°

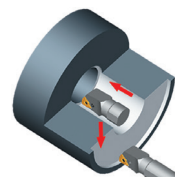
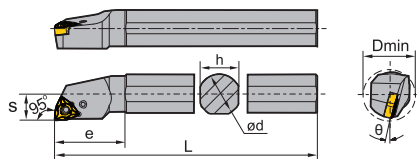
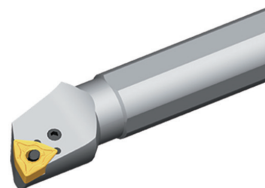

Right hand style

Article	*	Stock		Dimensions [mm]							Inserts
		R	L	ød	L	h	s	e	D <sub>min</sub>	θ	
S16M-PWLNR/L06		●	16	150	15	11	25	20	-13	WN**0604**	
S16M-PWLNR/L06		●	16	150	15	11	25	20	-13	WN**0604**	
S16R-PWLNR/L06		○	16	200	15	11	25	20	-13	WN**0604**	
S20Q-PWLNR/L06		●	20	180	18	13	35	25	-13	WN**0604**	
S20S-PWLNR/L06		●	20	250	18	13	35	25	-13	WN**0604**	
S25Q-PWLNR/L06		○	25	180	23	17	35	32	-13	WN**0604**	
S25T-PWLNR/L06		○	25	300	23	17	35	32	-13	WN**0604**	
S20Q-PWLNR/L08		●	20	180	18	13	32	25	-13	WN**0804**	
S20S-PWLNR/L08		●	20	250	18	13	32	25	-13	WN**0804**	
S25Q-PWLNR/L08		●	25	180	23	17	45	32	-13	WN**0804**	
S25T-PWLNR/L08		●	25	300	23	17	45	32	-13	WN**0804**	
S32R-PWLNR/L08		●	32	200	30	22	50	40	-15	WN**0804**	
S32U-PWLNR/L08		●	32	350	30	22	50	40	-15	WN**0804**	
S50W-PWLNR/L08		○	50	450	47	35	50	63	-15	WN**0804**	

● Ex stock ○ On demand

\* With internal cooling

### Spare parts

	Insert	WN**0604**	WN**0804**	WN**0804**	WN**0804**
		16-25	20-25	32	50
Knee lever		L3B	L4A	L4	L4
Screw		LEM5×12B (4.0 Nm)		LEM8×21 (10.2 Nm)	LEM8×21 (10.2 Nm)
Screw			LEM6×13.4A (7.0 Nm)		
Screw				SP4	SP4
Shim pin (shim)				W08AP	W08AP
Shim				WH30L	WH30L
Wrench			WH25L		
Wrench		WT09IP			

System code > A322

Grade selection > A42

Technical info > A501

Cutting data > A366

**WN\*\* steel boring bar**

Insert					
					
<b>Wiper</b>	<b>Finishing</b>	<b>Medium Cut</b>	<b>Roughing</b>	<b>Cast Iron</b>	<b>PCBN/PCD</b>
A106	A107	A107	A109	A111	A165

**A**

Turning

**B**

Milling

**C**

Drilling

**D**

Technical Information

**E**

Index

System code > A322

Grade selection > A42

Technical info > A501

Cutting data > A366

## CC\*\* steel boring bar S-Clamping

SCLCR/L Kr: 95°

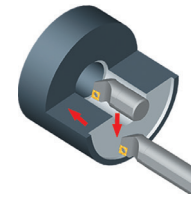
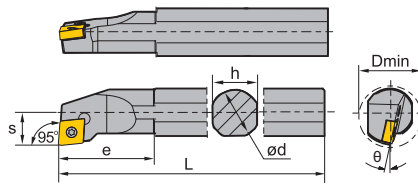
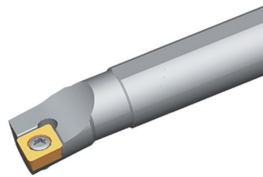

Right hand style

Article	*	Stock		Dimensions [mm]								Inserts
		R	L	ød	L	h	s	L <sub>2</sub>	e	D <sub>min</sub>	θ	
S08K-SCLCR/L06		●	●	8	125	7	5	14	14	10	-15	CC**0602**
S10K-SCLCR/L06		●	●	10	125	7	5	14	14	10	-15	CC**0602**
S10M-SCLCR/L06		●	●	10	150	9	6	14	14	12	-13	CC**0602**
S12M-SCLCR/L06		●	●	12	150	11	9	25	25	16	-10	CC**0602**
A08F-SCLCR/L06	*	●	●	8	80	7.5	5	14	14	10	-15	CC**0602**
A10H-SCLCR/L06	*	●	●	10	100	9.5	6	14	14	12	-13	CC**0602**
A12K-SCLCR/L06	*	●	●	12	125	11.5	9	25	25	16	-10	CC**0602**
S12M-SCLCR/L09		●	●	12	150	11	9	25	25	16	-10	CC**09T3**
S16M-SCLCR/L09		●	○	16	150	15	11	32.5	32.5	20	-12	CC**09T3**
S16R-SCLCR/L09		●	●	16	200	15	11	32.5	32.5	20	-12	CC**09T3**
S20Q-SCLCR/L09		●	●	20	180	18	13	38	38	25	-8	CC**09T3**
S20S-SCLCR/L09		●	●	20	250	18	13	38	38	25	-8	CC**09T3**
S25Q-SCLCR/L09		●	○	25	180	23	17	45	45	32	-6	CC**09T3**
S25T-SCLCR/L09		●	●	25	300	23	17	45	45	32	-6	CC**09T3**
A12K-SCLCR/L09	*	●	●	12	125	11.5	9	25	25	16	-10	CC**09T3**
A16M-SCLCR/L09	*	●	●	16	150	15.5	11	32.5	32.5	20	-12	CC**09T3**
A20Q-SCLCR/L09	*	●	●	20	180	19	13	38	38	25	-8	CC**09T3**
A25R-SCLCR/L09	*	●	●	25	200	24	17	45	45	32	-6	CC**09T3**
S25Q-SCLCR/L12		●	○	25	180	23	17	45	45	32	-6	CC**1204**
S25T-SCLCR/L12		●	●	25	300	23	17	45	45	32	-6	CC**1204**
S32R-SCLCR/L12		●	●	32	200	30	22	50	50	40	-10	CC**1204**
S32U-SCLCR/L12		●	●	32	350	30	22	50	50	40	-10	CC**1204**
S40S-SCLCR/L12		○		40	250	37	27	60	60	50	-8	CC**1204**
S40V-SCLCR/L12		●	●	40	400	37	27	60	60	50	-8	CC**1204**
A25R-SCLCR/L12	*	●	●	25	200	24	17	45	45	32	-6	CC**1204**
A32T-SCLCR/L12	*	○		32	300	30	22			40	-10	CC**1204**
A32S-SCLCR/L12	*	●	●	32	250	31	22	50	50	40	-10	CC**1204**

● Ex stock ○ On demand

\* With internal cooling

System code > A322







Grade selection > A42

Technical info > A501



Cutting data > A366

### CC\*\* steel boring bar

Spare parts

	Insert ød	CC**0602** 8-12	CC**09T3** 12-20	CC**09T3** 25	CC**1204** 25	CC**1204** 32-40
	Screw	I60M2.5×5.5 (1.0 Nm)	I60M3.5×8 (2.7 Nm)	I60M3.5×10 (2.7 Nm)		
	Screw				I60M4×11X (3.4 Nm)	I60M4×11X (3.4 Nm)
	Screw (shim)					SM6×10XA
	Shim					C12B5
	Wrench (screw)	WT07IP	WT15IP	WT15IP	WT15IP	WT15IP
	Wrench (shim)					WH40L

Insert

					
<b>Finishing</b>	<b>Medium Cut</b>	<b>Roughing</b>	<b>Alum Machining</b>	<b>Cast Iron</b>	<b>PCBN/PCD</b>
A116	A119	A121	A122	A121	A180

A

Turning

B

Milling

C

Drilling

D

Technical  
Information

E

Index

System code > A322

Grade selection > A42

Technical info > A501

Cutting data > A366



# General turning Boring bars

DC\*\* steel boring bar **S-Clamping**

SDQCR/L Kr: 107°30'

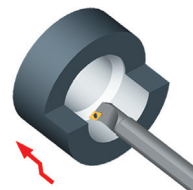
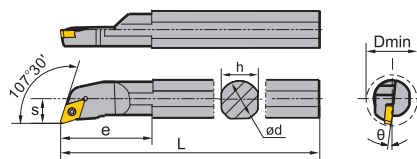
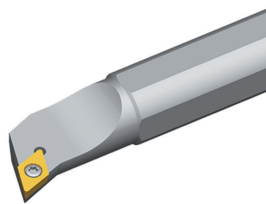

Right hand style

Article	*	Stock		Dimensions [mm]								Inserts
		R	L	ød	L	h	s	L <sub>2</sub>	e	D <sub>min</sub>	θ	
S10M-SDQCR/L07		●	●	10	150	9	7	20	20	13	-8	DC**0702**
S12M-SDQCR/L07		●	●	12	150	11	9	22	22	16	-8	DC**0702**
S16M-SDQCR/L07		○	●	16	150	15	11	27	27	20	-6	DC**0702**
S16Q-SDQCR/L07		●	●	16	180	15	11	27	27	20	-6	DC**0702**
S16R-SDQCR/L07		●	●	16	200	15	11	27	27	20	-6	DC**0702**
A10H-SDQCR/L07	*	●	●	10	100	9.5	7	20	20	13	-8	DC**0702**
A12K-SDQCR/L07	*	●	●	12	125	11.5	9	22	22	16	-8	DC**0702**
S20Q-SDQCR/L11		●	○	20	180	18	13	32	32	25	-6	DC**11T3**
S20S-SDQCR/L11		●	●	20	250	18	13	32	32	25	-6	DC**11T3**
S25Q-SDQCR/L11		●	○	25	180	23	17	32	32	32	-6	DC**11T3**
S25T-SDQCR/L11		●	●	25	300	23	17	32	32	32	-6	DC**11T3**
A16M-SDQCR/L11	*	●	●	16	150	15.5	11	27	27	20	-6	DC**11T3**
A20Q-SDQCR/L11	*	●	●	20	180	19	13	32	32	25	-6	DC**11T3**
A25R-SDQCR/L11	*	●	●	25	200	24	17	32	32	32	-6	DC**11T3**

● Ex stock ○ On demand

\* With internal cooling

### Spare parts

	Insert	DC**0702**	DC**0702**	DC**11T3**	DC**11T3**	DC**11T3**
	ød	10	12-16	16-20	20	25
Screw		I60M2.5x5.5 (1.0 Nm)	I60M2.5x6.5 (1.0 Nm)	I60M3.5x8 (2.7 Nm)	I60M3.5x8 (2.7 Nm)	I60M3.5x10 (2.7 Nm)
Wrench (screw)		WT07IP	WT07IP	WT15IP	WT15IP	WT15IP

### Insert

<b>Finishing</b> A126	<b>Medium Cut</b> A127	<b>Roughing</b> A129	<b>Alum Machining</b> A129	<b>Cast Iron</b> A129	<b>PCBN/PCD</b> A184

System code > A322

Grade selection > A42

Technical info > A501

Cutting data > A366

**DC\*\* steel boring bar S-Clamping**

SDUCR/L Kr: 93°

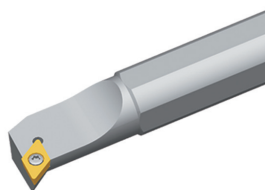

Right hand style

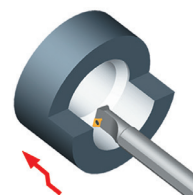
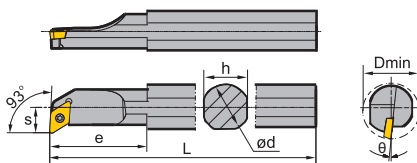

Article	*	Stock		Dimensions [mm]								Inserts
		R	L	ød	L	h	s	L <sub>2</sub>	e	D <sub>min</sub>	θ	
S10M-SDUCR/L07	●	●	10	150	9	7	-	0	13	-8	DC**0702**	
S12M-SDUCR/L07	●	●	12	150	11	9	22	22	16	-8	DC**0702**	
S16M-SDUCR/L07	●	●	16	150	15	11	27	27	20	-6	DC**0702**	
S16R-SDUCR/L07	●	●	16	200	15	11	27	27	20	-6	DC**0702**	
A10H-SDUCR/L07	*	●	10	100	9.5	7	-	0	13	-8	DC**0702**	
A12K-SDUCR/L07	*	●	12	125	11.5	9	22	22	16	-8	DC**0702**	
A16M-SDUCR/L07	*	●	16	150	15.5	11	27	27	20	-6	DC**0702**	
S20Q-SDUCR/L11	●	●	20	180	18	13	40	40	25	-6	DC**11T3**	
S20S-SDUCR/L11	●	●	20	250	18	13	40	40	25	-6	DC**11T3**	
S25Q-SDUCR/L11	●	○	25	180	23	17	46	46	32	-6	DC**11T3**	
S25T-SDUCR/L11	●	●	25	300	23	17	46	46	32	-6	DC**11T3**	
A16R-SDUCR/L11	*	○	16	200	15	14.5	27	27	23	-6	DC**11T3**	
A20Q-SDUCR/L11	*	●	20	180	19	13	40	40	25	-6	DC**11T3**	
A25R-SDUCR/L11	*	●	25	200	24	17	46	46	32	-6	DC**11T3**	

● Ex stock ○ On demand

\* With internal cooling

Spare parts			
Insert	DC**0702**	DC**11T3**	
ød	10-16	16-25	
Screw	I60M2.5×5.5 (1.0 Nm)	I60M3.5×8 (2.7 Nm)	
Wrench	WT07IP	WT15IP	

Insert					
Finishing A126	Medium Cut A127	Roughing A129	Alum Machining A129	Cast Iron A129	PCBN/PCD A184

## DC\*\* steel boring bar S-Clamping

SDZCR/L Kr: 85°

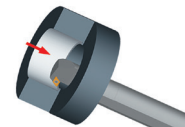
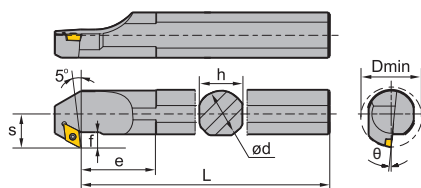
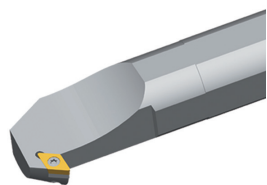

Right hand style

Article	*	Stock		Dimensions [mm]								Inserts
		R	L	ød	L	h	s	e	f	D <sub>min</sub>	θ	
S25Q-SDZCR/L11	•	•	25	180	23	17	30	6.9	32	-6	DC**11T3**	
S25T-SDZCR/L11	•	•	25	300	23	17	30	6.9	32	-6	DC**11T3**	
S32R-SDZCR/L11	○		32	200	30	22	39	8.4	40	-6	DC**11T3**	
S32U-SDZCR/L11	•	•	32	350	30	22	39	8.4	40	-6	DC**11T3**	
S40S-SDZCR/L11	○	•	40	250	37	27	47	9.4	50	-4	DC**11T3**	
S40V-SDZCR/L11	•	•	40	400	37	27	47	9.4	50	-4	DC**11T3**	
A25R-SDZCR/L11	*	•	25	200	24	17	30	4.5	32	-6	DC**11T3**	
A32S-SDZCR/L11	*	•	32	250	31	22	39	6	40	-6	DC**11T3**	

• Ex stock ○ On demand

\* With internal cooling

### Spare parts

	Insert	DC**11T3**	DC**11T3**
	ød	25	32-40
	Screw	I60M3.5x10 (2.7 Nm)	I60M3.5x12 (2.7 Nm)
	Screw (shim)		SM5x8.65XA
	Shim		D11BS
	Wrench (screw)	WT15IP	WT15IP
	Wrench (shim)		WH35L

### Insert

Finishing A126	Medium Cut A127	Roughing A129	Alum Machining A129	Cast Iron A129	PCBN/PCD A184

**SC\*\* steel boring bar S-Clamping**

SSKCR/L Kr: 75°

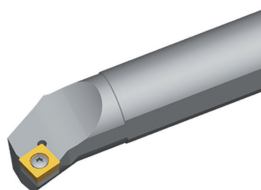

Right hand style

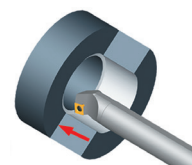
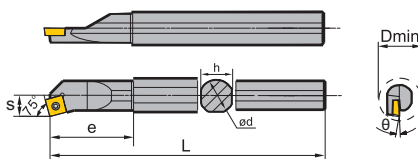

Article	*	Stock		Dimensions [mm]							Inserts
		R	L	ød	L	h	s	e	D <sub>min</sub>	θ	
S12M-SSKCR/L09	●	●	12	150	11	9	26	16	-10	SC**09T3**	
S16M-SSKCR/L09	○	○	16	150	15	11	32.5	20	-11	SC**09T3**	
S16R-SSKCR/L09	○	○	16	200	15	11	32.5	20	-11	SC**09T3**	
S20Q-SSKCR/L09	○	○	20	180	18	13	34.5	25	-6	SC**09T3**	
S20S-SSKCR/L09	●	○	20	250	18	13	34.5	25	-6	SC**09T3**	
A12K-SSKCR/L09	*	●	○	12	125	11	9	26	-10	SC**09T3**	
A16M-SSKCR/L09	*	●	○	16	150	15	11	32.5	-11	SC**09T3**	
A20Q-SSKCR/L09	*	●	○	20	180	19	13	34.5	-6	SC**09T3**	
S25Q-SSKCR/L12	○	○	25	180	23	17	36.3	32	-8	SC**1204**	
S25T-SSKCR/L12	●	○	25	300	23	17	36.3	32	-8	SC**1204**	
S32R-SSKCR/L12	○	○	32	200	30	22	43.5	40	-10	SC**1204**	
S32U-SSKCR/L12	●	○	32	350	30	22	43.5	40	-10	SC**1204**	
A25R-SSKCR/L12	*	●	○	25	200	24	17	41.3	-8	SC**1204**	
A32S-SSKCR/L12	*	●	○	32	250	31	22	42.8	-10	SC**1204**	

● Ex stock ○ On demand

\* With internal cooling

Spare parts

	Insert ød	SC**09T3**	SC**1204**	SC**1204**
		12-20	25	32
	Screw	I60M3.5x8 (2.7 Nm)		
	Screw		I60M4x11X (3.4 Nm)	I60M4x11X (3.4 Nm)
	Screw (shim)			SM6x10XA
	Shim			S12BS
	Wrench (screw)	WT15IP	WT15IP	WT15IP
	Wrench (shim)			WH40L

System code > A322

Grade selection > A42

Technical info > A501

Cutting data > A366



A

Turning

B

Milling

C

Drilling

D

Technical Information





E

Index

**A**

Turning

## SC\*\* steel boring bar

Insert			
			
<b>Finishing</b>	<b>Medium Cut</b>	<b>Roughing</b>	<b>Alum Machining</b>
A134	A135	A136	A136

**B**

Milling

**C**

Drilling

**D**

Technical Information

**E**

Index

System code > A322

Grade selection > A42

Technical info > A501

Cutting data > A366

**TC\*\* steel boring bar S-Clamping**

STFCR/L Kr: 91°

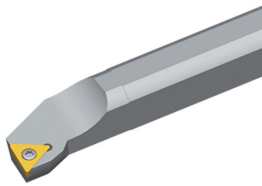

Right hand style

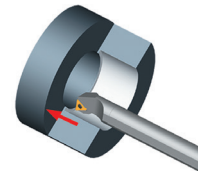
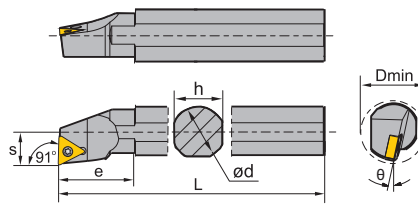

Article	*	Stock		Dimensions [mm]							Inserts
		R	L	ød	L	h	s	e	D <sub>min</sub>	θ	
S12M-STFCR/L11	●	●	12	150	11	9	30	16	-10	TC**1102**	
S16M-STFCR/L11	○	●	16	150	15	11	35	20	-6	TC**1102**	
S16R-STFCR/L11	●	●	16	200	15	11	35	20	-6	TC**1102**	
S20Q-STFCR/L11	○	○	20	180	18	13	36	25	-3	TC**1102**	
S20S-STFCR/L11	●	●	20	250	18	13	36	25	-3	TC**1102**	
A12K-STFCR/L11	*	●	12	125	11.5	9	26	16	-10	TC**1102**	
A16M-STFCR/L11	*	●	16	150	15.5	11	30	20	-6	TC**1102**	
A20Q-STFCR/L11	*	●	20	180	19	13	36	25	-3	TC**1102**	
S25Q-STFCR/L16	●	○	25	180	23	17	49	32	-6	TC**16T3**	
S25T-STFCR/L16	●	●	25	300	23	17	49	32	-6	TC**16T3**	
S32R-STFCR/L16	●	●	32	200	30	22	50	40	-10	TC**16T3**	
S32U-STFCR/L16	●	●	32	350	30	22	50	40	-10	TC**16T3**	
S40S-STFCR/L16	○	○	40	250	37	27	60	50	-8	TC**16T3**	
S40V-STFCR/L16	●	●	40	400	37	27	60	50	-8	TC**16T3**	
A25R-STFCR/L16	*	●	25	200	24	17	45	32	-6	TC**16T3**	
A32S-STFCR/L16	*	●	32	250	31	22	49	40	-10	TC**16T3**	

● Ex stock ○ On demand

\* With internal cooling







Spare parts

Insert ød	TC**1102**	TC**16T3**	TC**16T3**
	12-20	25	32-40
Screw	I60M2.5×6.5 (1.0 Nm)	I60M3.5×10 (2.7 Nm)	I60M3.5×12 (2.7 Nm)
Screw (shim)			SM5×8.65XA
Shim			T16BS
Wrench (screw)	WT07IP	WT15IP	WT15IP
Wrench (shim)			WH35L

**A**

Turning

## TC\*\* steel boring bar

Insert					
					
Finishing	Medium Cut	Roughing	Alum Machining	Cast Iron	PCBN/PCD
A141	A142	A143	A145	A143	A187

**B**

Milling

**C**

Drilling

**D**

Technical Information

**E**

Index

System code > A322

Grade selection > A42

Technical info > A501

Cutting data > A366

**VC\*\* steel boring bar S-Clamping**

SVQCR/L Kr: 107°30'

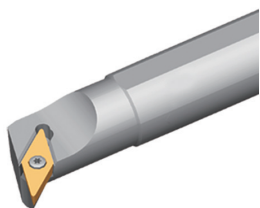

Right hand style

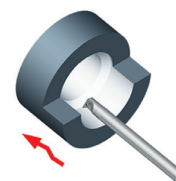
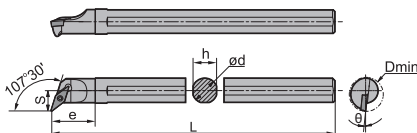

Article	*	Stock		Dimensions [mm]						Inserts
		R	L	ød	L	h	s	e	D <sub>min</sub>	
S16Q-SVQCR/L11	●	●	16	180	15	13	28	22	-6	VC**1103**
S20R-SVQCR/L11	●	○	20	200	18	15	32	26	-4	VC**1103**

● Ex stock ○ On demand

\* With internal cooling

Spare parts

	Insert	VC**1103**
	ød	16-20
	Screw	I60M2.5×6.5 (1.0 Nm)
	Wrench (screw)	WT07IP

Insert

Finishing	Alum Machining	PCBN/PCD
A156	A154	A193

**A**

Turning

**B**

Milling

**C**

Drilling

**D**

Technical Information

**E**

Index



## VC\*\* steel boring bar S-Clamping

SVUCR/L Kr: 93°

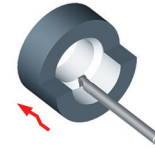
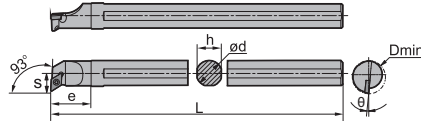
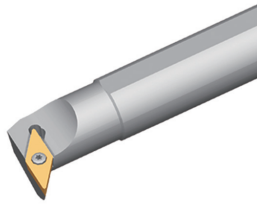

Right hand style

Article	*	Stock		Dimensions [mm]								Inserts
		R	L	ød	L	h	s	L <sub>2</sub>	e	D <sub>min</sub>	θ	
S16Q-SVUCR/L11	● ○	16	180	15	15	25	25	24	-6	VC**1103**		
S20R-SVUCR/L11	● ●	20	200	18	17	30	30	28	-4	VC**1103**		
S40U-SVUCR/L16	○	40	350	37	27	56	56	50	-8	VC**1604**		

● Ex stock ○ On demand

\* With internal cooling

### Spare parts

	Insert	VC**1103**	VC**1604**
	ød	16-20	40
	Screw	I60M2.5×6.5 (1.0 Nm)	I60M3.5×12 (2.7 Nm)
	Screw (shim)		SM5×8.65XA (4.0 Nm)
	Shim		V16BSC
	Wrench (screw)	WT07IP	WT15IP
	Wrench (shim)		WH35L

### Insert

<b>Finishing</b>	<b>Medium Cut</b>	<b>Alum Machining</b>	<b>PCBN/PCD</b>
A156	A156	A154	A193

**VB\*\* steel boring bar S-Clamping**

SVQBR/L Kr: 107°30'

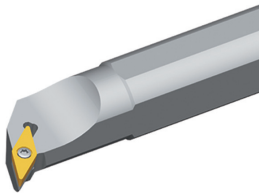

Right hand style

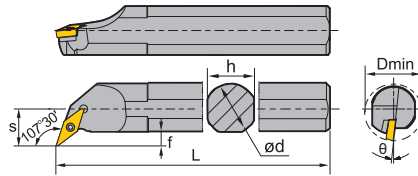





Article	*	Stock		Dimensions [mm]								Inserts
		R	L	ød	L	h	s	e	f	D <sub>min</sub>	θ	
S32R-SVQBR/L16	●	●	32	200	30	22	56	8.4	40	-8	VB**1604**	
S32U-SVQBR/L16	●	●	32	350	30	22	56	8.4	40	-8	VB**1604**	
S40V-SVQBR/L16	●	●	40	400	37	27	64	9.4	50	-8	VB**1604**	
A32S-SVQBR/L16	* ○	○	32	250	31	22	56	8.4	40	-8	VB**1604**	





● Ex stock ○ On demand

\* With internal cooling

Spare parts

	Insert ød	VB**1604** 32-40
	Screw	I60M3.5×12 (2.7 Nm)
	Screw (shim)	SM5×8.65XA
	Shim	V16BS
	Wrench (screw)	WT15IP
	Wrench (shim)	WH35L

Insert

			
<b>Finishing</b> A148	<b>Medium Cut</b> A151	<b>Roughing</b> A152	<b>PCBN/PCD</b> A191

## VB\*\* steel boring bar S-Clamping

SVUBR/L Kr: 93°

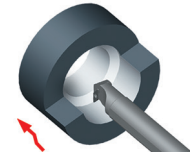
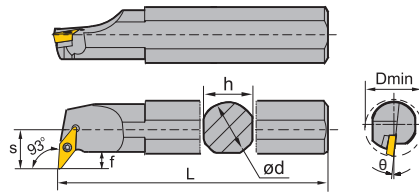
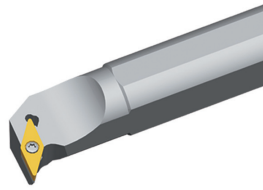

Right hand style

Article	*	Stock		Dimensions [mm]								Inserts
		R	L	ød	L	h	s	e	f	D <sub>min</sub>	θ	
S32R-SVUBR/L16		●	○	32	200	30	22	49	8.4	40	-8	VB**1604**
S32U-SVUBR/L16		●	●	32	350	30	22	49	8.4	40	-8	VB**1604**
S40S-SVUBR/L16		●	○	40	250	37	27	56.5	9.4	50	-8	VB**1604**
S40V-SVUBR/L16		●	●	40	400	37	27	56.5	9.4	50	-8	VB**1604**
A32S-SVUBR/L16	*	●	●	32	250	31	22	49	8.4	40	-8	VB**1604**

● Ex stock ○ On demand

\* With internal cooling

### Spare parts

	Insert ød	VB**1604** 32-40
	Screw	I60M3.5×12 (2.7 Nm)
	Screw (shim)	SM5×8.65XA
	Shim	V16BS
	Wrench (screw)	WT15IP
	Wrench (shim)	WH35L

### Insert

<b>Finishing</b> A148	<b>Medium Cut</b> A151	<b>Roughing</b> A152	<b>PCBN/PCD</b> A191

System code > A322

Grade selection > A42

Technical info > A501

Cutting data > A366

**VB\*\* steel boring bar S-Clamping**

SVXBR/L Kr: 93°

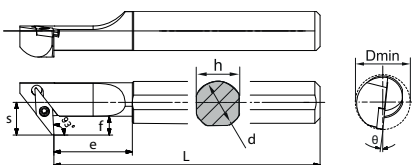
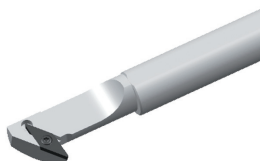

Right hand style

Article	Stock		Dimensions [mm]								Inserts
	R	L	ød	L	h	s	e	f	D <sub>min</sub>	θ	
S16P-SVXBR/L1102-KR93	○	○	16	170	15	12.5	30	72	21	-8	VB**1102**
S16P-SVXBR/L11-KR93	○	○	16	170	15	12.5	30	72	21	-8	VB**1103**
S20R-SVXBR/L11-KR93	○	○	20	187	20	13	22	5.7	25	-8	VB**1103**
S25S-SVXBR/L16-KR93	○	○	25	235	25	19	26	10.2	32	-8	VB**1604**
S32T-SVXBR/L16-KR93	○	○	32	280	32	22	80	11.7	40	-8	VB**1604**
S40M-SVXBR/L16-KR93	○	○	40	130	40	27	40	14.3	50	-8	VB**1604**
S40U-SVXBR/L16-KR93	○	○	40	330	40	27	90	14.3	50	-8	VB**1604**

- Ex stock    ○ On demand
- \* With internal cooling

Spare parts

	Insert ød	VB**1102**	VB**1103**	VB**1604**
		16-20	16-20	25-40
	Screw	I60M2.5x6.5 (1.0 Nm)	I60M2.5x6.5 (1.0 Nm)	I60M3.5x12 (2.7 Nm)
	Screw (shim)			SM5x8.65XA (4.0 Nm)
	Shim			V16BS
	Wrench (screw)			WT15IP
	Wrench (shim)			WH35L
	Wrench	WT07IP	WT07IP	WT15IP

Insert

<b>Finishing</b> A148	<b>Medium Cut</b> A151	<b>Roughing</b> A152	<b>PCBN/PCD</b> A191

System code > A322

Grade selection > A42

Technical info > A501

Cutting data > A366



A

Turning

B

Milling

C

Drilling

D

Technical Information

E

Index

## CP\*\* steel boring bar S-Clamping

SCLPR/L Kr: 95°

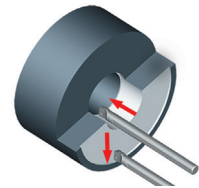
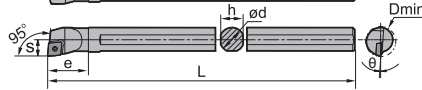
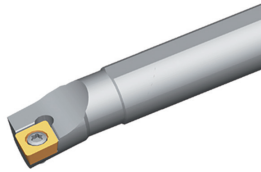



Right hand style

Article	Stock		Dimensions [mm]								Inserts
	R	L	ød	L	h	s	e	D <sub>min</sub>	θ		
S10K-SCLPR/L06	●	●	10	125	9	6	17	12	-7	CP**0602**	
S12M-SCLPR/L06	●	●	12	150	11	8	20	16	-4	CP**0602**	
S16Q-SCLPR/L09	●	●	16	180	15	10	29	20	-4	CP**09T3**	
S20R-SCLPR/L09	○	○	20	200	18	13	35	25	-4	CP**09T3**	

● Ex stock ○ On demand

\* With internal cooling

### Spare parts

	Insert	CP**0602**	CP**09T3**
	ød	10-12	20-25
	Screw	I60M2.5×5.5 (1.0 Nm)	I60M3.5×8 (2.7 Nm)
	Wrench (screw)	WT07IP	WT15IP

### Insert

Insert	Medium Cut	Cast Iron
		
Finishing	Medium Cut	Cast Iron
A124	A124	A124

System code > A322

Grade selection > A42

Technical info > A501

Cutting data > A366

**DP\*\* steel boring bar** **S-Clamping**

SDQPR/L Kr: 107°30'

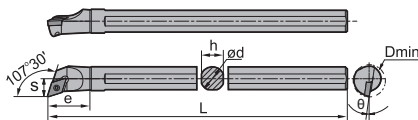
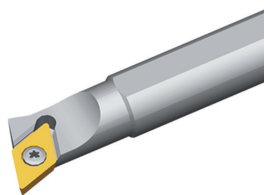



Right hand style

Article	*	Stock		Dimensions [mm]							Inserts
		R	L	ød	L	h	s	e	D <sub>min</sub>	θ	
S10K-SDQPR/L07	●	●	10	125	9	7	20	13	-8	DP**0702**	
S12M-SDQPR/L07	●	●	12	150	11	9	22	16	-8	DP**0702**	
S16Q-SDQPR/L07	●	●	16	180	15	11	27	20	-6	DP**0702**	
S16Q-SDQPR/L11	●	●	16	180	15	11	32	20	-6	DP**11T3**	
S20R-SDQPR/L11	○	○	20	200	18	13	33	25	-6	DP**11T3**	

● Ex stock ○ On demand

\* With internal cooling

Spare parts

	Insert	DP**0702**	DP**0702**	DP**11T3**
	ød	10-12	16	16-20
	Screw	I60M2.5×5.5 (1.0 Nm)	I60M2.5×6.5 (1.0 Nm)	I60M3.5×8 (2.7 Nm)
	Wrench (screw)	WT07IP	WT07IP	WT15IP

Insert



Finishing

A131

## DP\*\* steel boring bar S-Clamping

SDUPR/L Kr: 93°

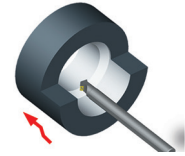
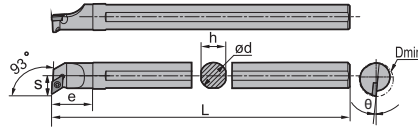
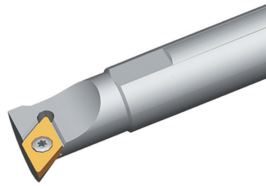



Right hand style

Article	Stock		Dimensions [mm]							Inserts
	R	L	ød	L	h	s	e	D <sub>min</sub>	θ	
S10K-SDUPR/L07	●	●	10	125	9	9	18	15	-8	DP**0702**
S12M-SDUPR/L07	●	●	12	150	11	9	19	16	-8	DP**0702**
S16Q-SDUPR/L07	●	●	16	180	15	11	25	20	-6	DP**0702**

● Ex stock    ○ On demand

\* With internal cooling

### Spare parts

	Insert	DP**0702**	DP**0702**
	ød	10-12	16
	Screw	I60M2.5×5.5 (1.0 Nm)	I60M2.5×6.5 (1.0 Nm)
	Wrench (screw)	WT07IP	WT07IP

### Insert



### Finishing

A131

A

Turning

B

Milling

C

Drilling

D

Technical Information

E

Index

TP\*\* steel boring bar **S-Clamping**

STUPR/L Kr: 93°

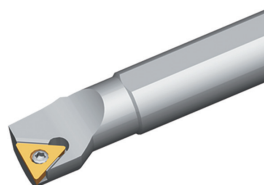

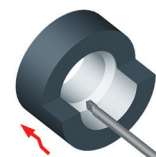
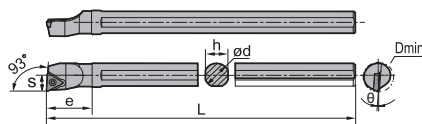

Right hand style



Article	*	Stock		Dimensions [mm]							Inserts
		R	L	ød	L	h	s	e	D <sub>min</sub>	θ	
S10K-STUPR/L09	●	●	10	125	9	6	20	12	-6	TP**0902**	
S12M-STUPR/L09	●	●	12	150	11	8	22	16	-4	TP**0902**	
S12M-STUPR/L11	●	●	12	150	11	8	25	16	-4	TP**1103**	
S16Q-STUPR/L11	●	●	16	180	15	10	27	20	-3	TP**1103**	

● Ex stock ○ On demand

\* With internal cooling

Spare parts			
	Insert	TP**0902**	TP**1103**
	ød	10-12	12-16
	Screw	I60M2.2×5.5 (0.8 Nm)	I60M2.5×6.5 (1.0 Nm)
	Wrench	WT07IP	WT07IP

Insert



Finishing

A147



## CC\*\* steel boring bar S-Clamping

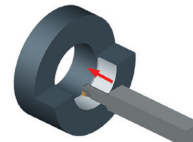
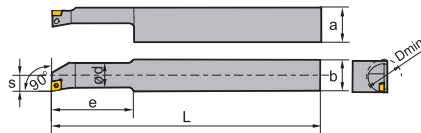
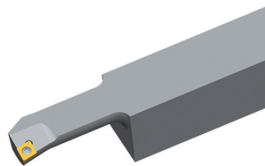

SCFCR/L Kr: 90°









Article	*	Stock		Dimensions [mm]							Inserts
		R	L	ød	a	b	L	s	e	D <sub>min</sub>	
S10M-SCFCR/L06S25	• ○	10	27	25	150	7	30	13	CC**0602**		
S12P-SCFCR/L06S25	•	12	27	25	170	9	35	16	CC**0602**		
S16Q-SCFCR/L09S25	• ○	16	27	25	180	11	40	20	CC**09T3**		
S20R-SCFCR/L09S25	•	20	27	25	200	13	45	25	CC**09T3**		
S25R-SCFCR/L12S25	• •	25	27	25	200	17	50	32	CC**1204**		

• Ex stock ○ On demand

\* With internal cooling

Spare parts				
	Insert	CC**0602**	CC**09T3**	CC**1204**
	ød	10-12	16-20	25
	Screw	I60M2.5×5.5 (1.0 Nm)	I60M3.5×8 (2.7 Nm)	I60M4×12 (3.4 Nm)
	Wrench	WT07IP	WT15IP	WT20IP

Insert					
					
<b>Finishing</b>	<b>Medium Cut</b>	<b>Roughing</b>	<b>Alum Machining</b>	<b>Cast Iron</b>	<b>PCBN/PCD</b>
A116	A119	A121	A122	A121	A180

System code > A322

Grade selection > A42

Technical info > A501

Cutting data > A366

**CC\*\* steel boring bar S-Clamping**

SCLCR Kr: 95°

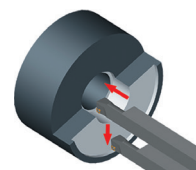
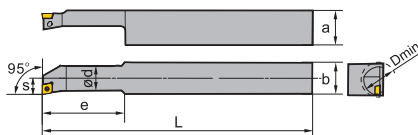
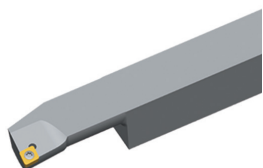

Article	*	Stock	Dimensions [mm]							Inserts
			ød	a	b	L	s	e	D <sub>min</sub>	
S10M-SCLCR06S20		○	10	22	20	150	7	30	13	CC**0602**
S12P-SCLCR06S20		○	12	22	20	170	9	35	16	CC**0602**
S16Q-SCLCR09S20		●	16	22	20	180	11	40	20	CC**09T3**
S20R-SCLCR09S20		●	20	22	20	200	13	60	25	CC**09T3**

● Ex stock ○ On demand

\* With internal cooling

Spare parts			
	Insert	CC**0602**	CC**09T3**
	ød	10-12	16-20
	Screw	I60M2.5x5.5 (1.0 Nm)	I60M3.5x8 (2.7 Nm)
	Wrench	WT07IP	WT15IP

Insert					
Finishing	Medium Cut	Roughing	Alum Machining	Cast Iron	PCBN/PCD
A116	A119	A121	A122	A121	A180

## CP\*\* solid carbide boring bar S-Clamping

SCLPR/L Kr: 95°

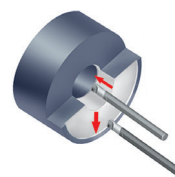
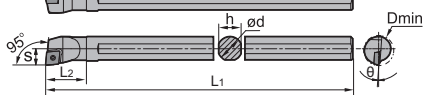
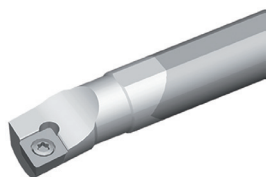



Right hand style

Article	*	Stock		Dimensions [mm]							Inserts
		R	L	∅D	∅d	h	s	L <sub>1</sub>	L <sub>2</sub>	θ	
C10M-SCLPR/L06	•	•	12	10	9	6	150	17	7	CP**0602**	
C12Q-SCLPR/L06	•	○	16	12	11	8	180	20	4	CP**0602**	
C16R-SCLPR/L09	•	•	20	16	15	10	200	29	4	CP**09T3**	
E16R-SCLPR/L09	*	○	19	16	15.5	10	200	-	-2	CP**09T3**	
C20S-SCLPR/L09	•	○	25	20	18	13	250	35	4	CP**09T3**	
E20S-SCLPR/L09	*	○	24	20	19.5	13	250	-	-2	CP**09T3**	

● Ex stock    ○ On demand

\* With internal cooling

### Spare parts

	Insert	CP**0602**	CP**09T3**
	∅d	10-12	16-20
	Screw	I60M2.5×5.5 (1.0 Nm)	I60M3.5×10 (2.7 Nm)
	Wrench (screw)	WT07IP	WT15IP

### Insert

		
<b>Finishing</b>	<b>Medium Cut</b>	<b>Cast Iron</b>
A124	A124	A124

System code > A322

Grade selection > A42

Technical info > A501

Cutting data > A366

**CC\*\* solid carbide boring bar** S-Clamping

SCLCR/L Kr: 95°

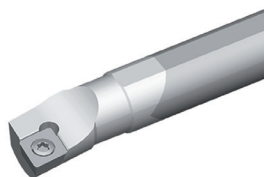

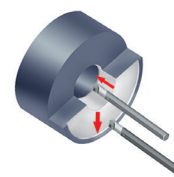
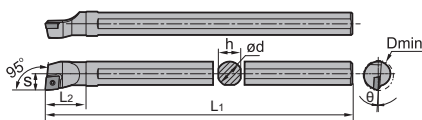

Right hand style









Article	*	Stock		Dimensions [mm]							Inserts
		R	L	ØD	ød	h	s	L <sub>1</sub>	L <sub>2</sub>	θ	
E08K-SCLCR/L06-09	*	●	●	9	8	7.5	5	125	-	-12	CC**0602**
E08K-SCLCR/L06-10	*	●	●	10	8	7.5	6	125	-	-12	CC**0602**
E10M-SCLCR/L06	*	●	●	12	10	9.5	7	150	-	-10	CC**0602**
E12Q-SCLCR/L06	*	●	●	15	12	11.5	9	180	-	-10	CC**0602**
E16R-SCLCR/L06	*	●	●	18	16	15.5	10	200	-	-8	CC**0602**
E12Q-SCLCR/L09	*	●	●	15	12	11.5	9	180	-	-9	CC**09T3**
E16R-SCLCR/L09	*	●	●	18	16	15.5	10	200	-	-10	CC**09T3**
E20S-SCLCR/L09	*	●	●	24	20	19.5	13	250	-	-8	CC**09T3**
E25T-SCLCR/L09	*	●	●	31	25	24	17	300	-	-6	CC**09T3**

● Ex stock ○ On demand

\* With internal cooling

Spare parts			
	Insert	CC**0602**	CC**09T3**
	ød	<b>8-16</b>	<b>12</b>
	Screw	I60M2.5x5.5 (1.0 Nm)	I60M3.5x8 (2.7 Nm)
	Wrench (screw)	WT07IP	WT15IP

Insert					
					
<b>Finishing</b>	<b>Medium Cut</b>	<b>Roughing</b>	<b>Alum Machining</b>	<b>Cast Iron</b>	<b>PCBN/PCD</b>
A116	A119	A121	A122	A121	A180

## DP\*\* solid carbide boring bar S-Clamping

SDQPR/L Kr: 107°30'

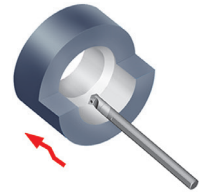
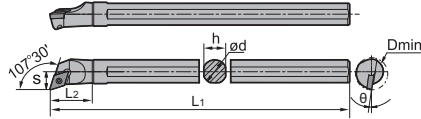
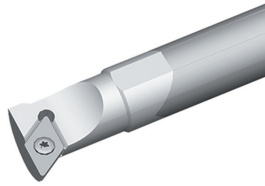



Right hand style

Article	*	Stock		Dimensions [mm]							Inserts
		R	L	ØD	ød	h	s	L <sub>1</sub>	L <sub>2</sub>	θ	
C10M-SDQPR/L07	●	●	13	10	9	7	150	20	8	DP**0702	
C12Q-SDQPR/L07	○	●	16	12	11	9	180	22	8	DP**0702	
C16R-SDQPR/L07	○	○	20	16	15	11	200	27	6	DP**0702	
C16R-SDQPR/L11	○	○	20	16	15	11	200	32	6	DP**11T3**	
C20S-SDQPR/L11	●	○	25	20	18	13	250	33	6	DP**11T3**	

● Ex stock ○ On demand

\* With internal cooling

### Spare parts

	Insert ød	DP**0702 10-12	DP**0702 16	DP**11T3** 16-20
 Screw		I60M2.5×5.5 (1.0 Nm)	I60M2.5×6.5 (1.0 Nm)	I60M3.5×8 (2.7 Nm)
 Wrench (screw)		WT07IP	WT07IP	WT15IP

### Insert



### Finishing

A131

A

Turning

B

Milling

C

Drilling

D

Technical Information

E

Index

System code > A322

Grade selection > A42

Technical info > A501

Cutting data > A366

**DC\*\* solid carbide boring bar** S-Clamping

SDQCR/L Kr: 107°30'

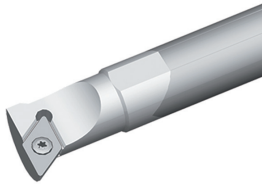

Right hand style

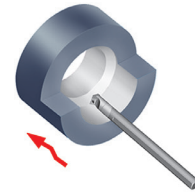
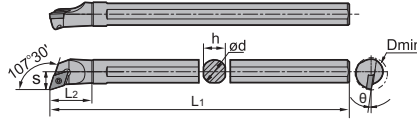

Article	*	Stock		Dimensions [mm]							Inserts
		R	L	ØD	ød	h	s	L <sub>1</sub>	L <sub>2</sub>	θ	
E08K-SDQCR/L07	*	●	●	11	8	7.5	6.5	125	-	-12	DC**0702**
E10M-SDQCR/L07	*	●	●	12	10	9.5	7	150	-	-10	DC**0702**
E12Q-SDQCR/L07	*	●	●	15	12	11.5	9	180	-	-10	DC**0702**
E16R-SDQCR/L07	*	●	○	18	16	15.5	10	200	27-	-6	DC**0702**
E20S-SDQCR/L07	*	●	○	24	20	19.5	13	250	33-	-4	DC**0702**
E16R-SDQCR/L11	*	●	●	18	16	15.5	10	200	-	-8	DC**11T3**
E20S-SDQCR/L11	*	●	○	24	20	19.5	13	250	-	-8	DC**11T3**
E25T-SDQCR/L11	*	●	○	31	25	24	17	300	-	-6	DC**11T3**

● Ex stock ○ On demand

\* With internal cooling

Spare parts

	Insert	DC**0702**	DC**11T3**
	ød	8-20	16-25
	Screw	I60M2.5x5.5 (1.0 Nm)	I60M3.5x10 (2.7 Nm)
	Wrench (screw)	WT07IP	WT15IP

Insert

Finishing A126	Medium Cut A127	Roughing A129	Alum Machining A129	Cast Iron A129	PCBN/PCD A184

System code > A322

Grade selection > A42

Technical info > A501

Cutting data > A366

## DP\*\* solid carbide boring bar S-Clamping

SDUPR/L Kr: 93°

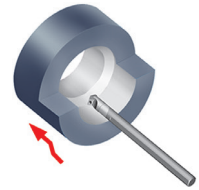
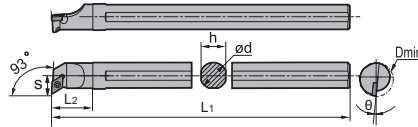
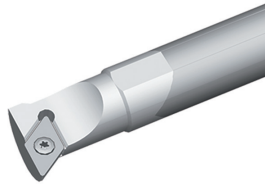



Right hand style

Article	Stock		Dimensions [mm]							Inserts
	R	L	ØD	ød	h	s	L <sub>1</sub>	L <sub>2</sub>	θ	
C10M-SDUPR/L07	●	●	15	10	9	9	150	18	8	DP**0702**
C12Q-SDUPR/L07	●	○	16	12	11	9	180	19	8	DP**0702**
C16R-SDUPR/L07	○	○	20	16	15	11	200	25	6	DP**0702**

● Ex stock ○ On demand

\* With internal cooling

### Spare parts

	<b>Insert</b>	<b>DP**0702**</b>
	<b>ød</b>	<b>15-20</b>
	Screw	I60M2.5×5.5 (1.0 Nm)
	Wrench	WT07IP

### Insert



### Finishing

A131

System code > A322

Grade selection > A42

Technical info > A501

Cutting data > A366

**DC\*\* solid carbide boring bar** S-Clamping

SDUCR/L Kr: 93°

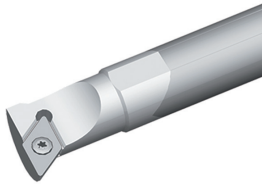

Right hand style

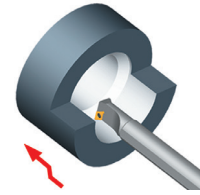
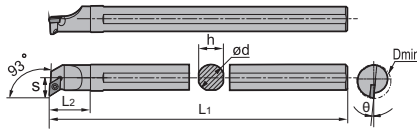

Article	*	Stock		Dimensions [mm]							Inserts
		R	L	∅D	ød	h	s	L <sub>1</sub>	L <sub>2</sub>	θ	
E10M-SDUCR/L07	*	●	○	12	10	9.5	7	150	-	-10	DC**0702**
E12Q-SDUCR/L07	*	●	●	15	12	11.5	9	180	-	-10	DC**0702**
E16R-SDUCR/L07	*	●	○	18	16	15.5	10	200	-	-6	DC**0702**
E20S-SDUCR/L07	*	○	○	24	20	19.5	13	250	-	-4	DC**0702**
E16R-SDUCR/L11	*	●	○	18	16	15.5	10	200	-	-8	DC**11T3**
E20S-SDUCR/L11	*	●	●	24	20	19.5	13	250	-	-8	DC**11T3**
E25T-SDUCR/L11	*	○	○	31	25	24	17	300	-	-6	DC**11T3**

● Ex stock ○ On demand

\* With internal cooling

Spare parts

	Insert	DC**0702**	DC**11T3**
	ød	10-20	16-25
	Screw	I60M2.5x5.5 (1.0 Nm)	I60M3.5x10 (2.7 Nm)
	Wrench (screw)	WT07IP	WT15IP

Insert

Finishing A126	Medium Cut A127	Roughing A129	Alum Machining A129	Cast Iron A129	PCBN/PCD A184

System code > A322

Grade selection > A42

Technical info > A501

Cutting data > A366



A

Turning

B

Milling

C

Drilling

D

Technical Information

E

Index



## TP\*\* solid carbide boring bar S-Clamping

STUPR/L Kr: 93°

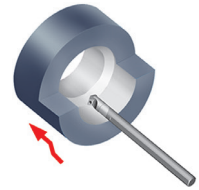
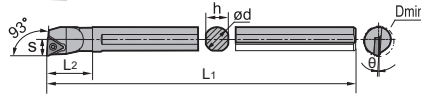
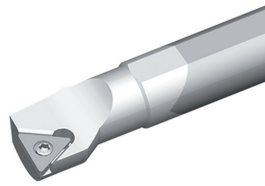



Right hand style

Article	Stock		Dimensions [mm]							Inserts
	R	L	ØD	ød	h	s	L <sub>1</sub>	L <sub>2</sub>	θ	
C10M-STUPR/L09	○	○	12	10	9	6	150	20	6	TP**0902**
C12Q-STUPR/L09	●		16	12	11	8	180	22	4	TP**0902**
C12Q-STUPR/L11	●		16	12	11	8	180	25	4	TP**1103
C16R-STUPR/L11	○	○	20	16	15	10	200	27	3	TP**1103

● Ex stock ○ On demand

\* With internal cooling

### Spare parts

	Insert	TP**0902**	TP**1103
		<b>10-12</b>	<b>12-16</b>
	Screw	I60M2.2×5.5 (0.8 Nm)	I60M2.5×6.5 (1.0 Nm)
	Wrench (screw)	WT07IP	WT07IP

### Insert



### Finishing

A147

A

Turning

B

Milling

C

Drilling

D

Technical Information

E

Index

System code > A322

Grade selection > A42

Technical info > A501

Cutting data > A366

**TC\*\* solid carbide boring bar** S-Clamping

STFCR/L Kr: 90°

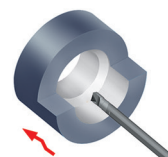
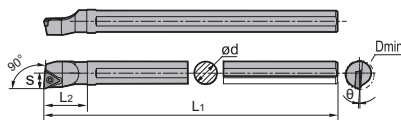
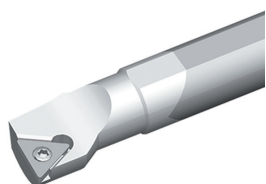

Right hand style

Article	*	Stock		Dimensions [mm]							Inserts
		R	L	ØD	ød	h	s	L <sub>1</sub>	L <sub>2</sub>	θ	
E08K-STFCR/L09	*	○	●	11	8	7.5	6	125	-	-12	TC**0902**
E10M-STFCR/L09	*	○	○	12	10	9.5	7	150	-	-10	TC**0902**
E12Q-STFCR/L11	*	○	○	15	12	11.5	9	180	-	-10	TC**1102**
E16R-STFCR/L11	*	○	○	18	16	15.5	10	200	-	-8	TC**1102**
E20S-STFCR/L11	*	○	○	24	20	19.5	13	250	-	-8	TC**1102**
E20S-STFCR/L16	*	○	○	24	20	19.5	13	250	-	-8	TC**16T3**
E25T-STFCR/L16	*	○	○	31	25	24	17	300	-	-6	TC**16T3**

- Ex stock    ○ On demand
- \* With internal cooling

Spare parts

	Insert	TC**0902**	TC**1102**	TC**16T3**
		8-10	12-20	20-25
	Screw	I60M2.2x5.5 (0.8 Nm)	I60M2.5x5.5 (1.0 Nm)	I60M3.5x10 (2.7 Nm)
	Wrench (screw)	WT07IP	WT07IP	WT15IP

Insert

Finishing A141	Medium Cut A142	Roughing A143	Alum Machining A145	Cast Iron A143	PCBN/PCD A187

System code > A322

Grade selection > A42

Technical info > A501

Cutting data > A366



A

Turning

B

Milling

C

Drilling

D

Technical Information

E

Index

## TC\*\* solid carbide boring bar S-Clamping

STFPR/L Kr: 90°

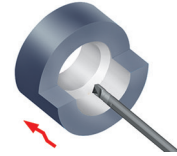
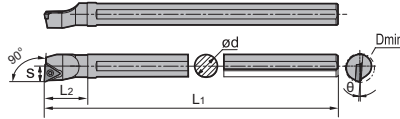
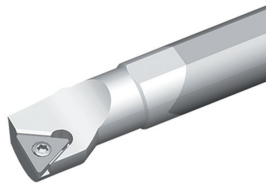



Right hand style

Article	*	Stock		Dimensions [mm]							Inserts
		R	L	ØD	ød	h	s	L <sub>1</sub>	L <sub>2</sub>	θ	
E10M-STFPR/L11	*	○	○	12	10	9.5	6	150	-	-5	TP**1103**
E12Q-STFPR/L11	*	○	○	15	12	11.5	8	180	-	-4	TP**1103**
E16R-STFPR/L11	*	○	○	19	16	15.5	10	200	-	-2	TP**1103**
E20S-STFPR/L11	*	○	○	24	20	19	13	250	-	-2	TP**1103**

● Ex stock    ○ On demand

\* With internal cooling

### Spare parts

	<b>Insert</b>	<b>TP**1103**</b>
		<b>10-20</b>
	Screw	I60M3.0×7.0 (1.8 Nm)
	Wrench (screw)	WT08IP

### Insert



### Finishing

A147

A

Turning

B

Milling

C

Drilling

D

Technical Information

E

Index

System code > A322

Grade selection > A42

Technical info > A501

Cutting data > A366

**VC\*\* solid carbide boring bar** S-Clamping

SVQCR/L Kr: 107°30'

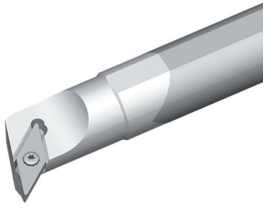

Right hand style

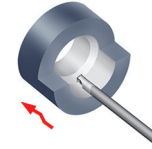
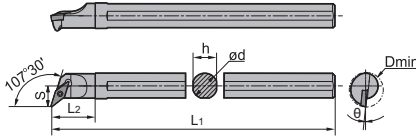

Article	*	Stock		Dimensions [mm]						Inserts
		R	L	ØD	ød	h	s	L <sub>1</sub>	L <sub>2</sub>	
C16R-SVQCR/L11	○	○	22	16	15	13	200	28	-6	VC**1103**
C20S-SVQCR/L11	○	○	26	20	18	15	250	32	-4	VC**1103**

● Ex stock ○ On demand

\* With internal cooling

Spare parts

	Insert	VC**1103** 16-20
	Screw	I60M2.5×6.5 (1.0 Nm)
	Wrench (screw)	WT07IP

Insert

Finishing	Alum Machining	PCBN/PCD
A156	A154	A193

System code > A322

Grade selection > A42

Technical info > A501

Cutting data > A366

## VC\*\* solid carbide boring bar S-Clamping

SVUCR/L Kr: 93°

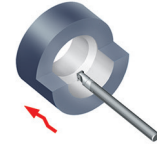
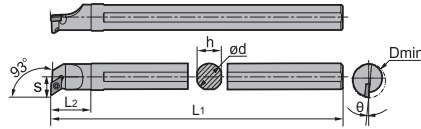
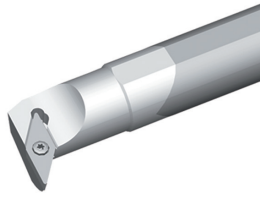

Right hand style

Article	*	Stock		Dimensions [mm]							Inserts
		R	L	ØD	ød	h	s	L <sub>1</sub>	L <sub>2</sub>	θ	
C16R-SVUCR/L11		○		24	16	15	15	200	25	6	VC**1103**
E16R-SVUCR/L11	*	○	○	22	16	15	13	200	-	-6.5	VC**1103**
C20S-SVUCR/L11		●	●	28	20	18	17	250	30	4	VC**1103**
E20S-SVUCR/L11	*	○	○	27	20	18	13	250	-	-6.5	VC**1103**
E25T-SVUCR/L16	*	○	○	35	25	23	20.5	300	-	-6.5	VC**1604**

● Ex stock ○ On demand

\* With internal cooling

### Spare parts

	Insert	VC**1103** 16-20	VC**1604** 25
	Screw	I60M2.5×6.5 (1.0 Nm)	I60M3.5×10 (2.7 Nm)
	Wrench (screw)	WT07IP	WT15IP

### Insert

Finishing	Medium Cut	Alum Machining	PCBN/PCD
A156	A156	A154	A193

System code > A322

Grade selection > A42

Technical info > A501

Cutting data > A366

**ZNEX solid carbide boring bar** **S clamping**

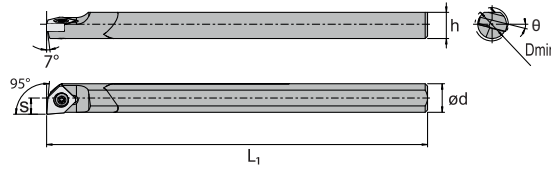

SZLNR Kr: 95°



Article	*	Stock		Dimensions [mm]						Insert	
		R	L	D <sub>min</sub>	ød	h	s	L <sub>1</sub>	L <sub>2</sub>	θ	
<b>C06X-SZLNR04</b>	●			7	6	5,5	3,4	80	-	-14	ZNEX0401**

● Ex stock ○ On demand

\* With internal cooling

Spare parts		
	<b>Insert</b>	<b>ZNEX0401**</b>
	<b>ød</b>	<b>6</b>
	Screw	I60M2x3,7 (0,5 Nm)
	Wrench (Screw)	WT06IP

**C06X\*\* holder**

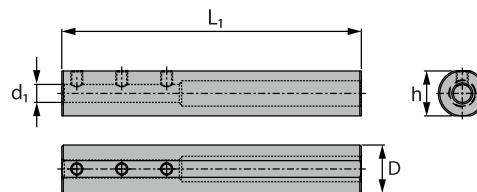
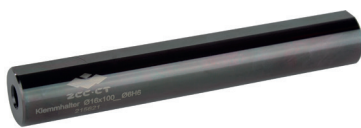

SZLNR Kr: 95°



Article	Stock	Dimensions [mm]			
		D	d <sub>1</sub>	L <sub>1</sub>	h
<b>SHSZ1600.06.100</b>	●	16	6	100	15

● Ex stock ○ On demand

\* With internal cooling

Spare parts		
	Screw	M4x5SH
	Wrench (Screw)	WH20L

Register on our website and order online now.



www.zcct-europe.com

## Turning insert, negative

	Material group	Composition / structure / heat treatment		Brinell hardness HB	Machining group	Starting values for cutting speed $v_c$ [m/min]									
						HC (CVD)									
						YBC103			YB6315			YBC152			
						Feed rate [mm]			Feed rate [mm]			Feed rate [mm]			
						0,1	0,2	0,6	0,1	0,2	0,6	0,1	0,2	0,6	
<b>P</b>	Unalloyed steel	approx. 0,15 % C	annealed	125	1	520	420	280	500	400	270	500	400	270	
		approx. 0,45 % C	annealed	190	2	440	360	250	420	340	230	420	340	230	
		approx. 0,45 % C	tempered	250	3	350	300	220	330	280	200	330	280	200	
		approx. 0,75 % C	annealed	270	4	340	290	210	320	270	190	320	270	190	
		approx. 0,75 % C	tempered	300	5	300	260	190	280	240	170	280	240	170	
	Low-alloyed steel			annealed	180	6	420	320	200	400	300	180	400	300	180
				tempered	275	7	300	250	170	280	230	150	280	230	150
				tempered	300	8	280	240	170	260	220	150	260	220	150
				tempered	350	9	250	210	140	230	190	120	230	190	120
		High-alloyed steel and high-alloyed tool steel			annealed	200	10	380	310	210	360	290	190	360	290
			hardened and tempered	325	11	210	180	150	190	160	130	190	160	130	
<b>M</b>	Stainless steel	ferritic/martensitic	annealed	200	12										
			martensitic	tempered	240	13									
			austenitic	quench hardened	180	14									
			austenitic-ferritic		230	15									
<b>K</b>	Grey cast iron	perlitic/ferritic		180	16										
		perlitic (martensitic)		260	17										
	Cast iron with spheroidal graphite	ferritic		160	18										
		perlitic		250	19										
	Malleable cast iron	ferritic		130	20										
		perlitic		230	21										
<b>N</b>	Aluminium wrought alloys	cannot be hardened		60	22										
		hardenable	hardened	100	23										
	Cast aluminium alloys	$\leq 12\%$ Si, cannot be hardened		75	24										
		$\leq 12\%$ Si, hardenable	hardened	90	25										
		$> 12\%$ Si, cannot be hardened		130	26										
	Copper and copper alloys (bronze/brass)	machining steel, PB > 1%		110	27										
		CuZn, CuSnZn		90	28										
	CuSn, Pb-free copper, electrolytic copper		100	29											
<b>S</b>	Heat-resistant alloys	Fe-based alloys	annealed	200	30										
			hardened	280	31										
		Ni or Co base	annealed	250	32										
			hardened	350	33										
		cast	320	34											
Titanium alloys	pure titanium		R <sub>m</sub> 400	35											
	$\alpha$ and $\beta$ alloys	hardened	R <sub>m</sub> 1050	36											
<b>H</b>	Hardened steel		hardened and tempered	55 HRC	37										
			hardened and tempered	60 HRC	38										
	Hard cast iron		cast	400	39										
	Hardened cast iron		hardened and tempered	55 HRC	40										
<b>X</b>	Non-metallic materials	Thermoplastics			41										
		Thermosetting plastics			42										
		Plastic, glass-fibre reinforced GFRP			43										
		Plastic, carbon fibre reinforced CFRP			44										
		Graphite			45										
		Wood			46										

Note: The given cutting values are guide values, which were determined under ideal conditions.  
 The values have to be adapted in individual cases.  
 For examples of material for cutting tool groups view page D11.

**A** Turning  
**B** Milling  
**C** Drilling  
**D** Technical Information  
**E** Index

Starting values for cutting speed $v_c$ [m/min]																							
HC (CVD)																							
YBC203			YBC252			YBC352			YBM153			YBM253			YBD102			YB7315			YBD152		
Feed rate [mm]			Feed rate [mm]			Feed rate [mm]			Feed rate [mm]			Feed rate [mm]			Feed rate [mm]			Feed rate [mm]			Feed rate [mm]		
0,1	0,4	0,8	0,1	0,4	0,8	0,2	0,5	1,0	0,2	0,4	0,6	0,2	0,4	0,6	0,1	0,3	0,4	0,1	0,3	0,5	0,1	0,3	0,5
480	370	230	480	370	230	430	330	220															
400	310	190	400	310	190	350	270	180															
310	250	160	310	250	160	260	210	150															
300	240	150	300	240	150	250	200	140															
260	210	130	260	210	130	210	170	120															
380	290	170	380	290	170	320	240	150															
260	210	140	260	210	140	200	170	120															
240	200	140	240	200	140	180	160	120															
220	180	110	220	180	110	150	130	90															
310	250	170	310	250	170	220	180	130															
150	130	100	150	130	100	-	-	-															
									380	295	210	350	265	180									
									190	155	120	150	110	65									
									250	200	150	200	140	80									
									200	160	130	160	115	70									
															530	380	220	600	410	220	540	375	210
															240	200	150	330	240	150	280	210	140
															300	210	145	340	250	160	290	215	140
															220	150	105	260	190	120	210	155	100
															330	265	220	370	300	230	320	265	210
															230	155	100	280	200	120	230	165	100

- HC Coated carbide
- HT Uncoated carbide, primary component (TiC) or (TiN), cermet
- HW Uncoated carbide, primary component (WC)
- BL Cubic boron nitride with low BN content
- BH Cubic boron nitride with high BN content
- CN Si3N4 ceramic
- CM Mixed ceramic
- HC1 Coated cermet
- BC CBN with coating
- CC Coated cutting ceramic
- CR Cutting ceramic, primary component aluminium oxide (Al2O3), reinforced
- DP Polycrystalline diamond



A

Turning

B

Milling

C

Drilling

D

Technical Information

E

Index



## Turning insert, negative

	Material group	Composition / structure / heat treatment		Brinell hardness HB	Machining group	Starting values for cutting speed $v_c$ [m/min]									
						HC (CVD)			HC (PVD)						
						YBD152C			YBG101			YBG102			
						Feed rate [mm]			Feed rate [mm]			Feed rate [mm]			
					0,1	0,3	0,5	0,1	0,3	0,6	0,1	0,3	0,6		
<b>P</b>	Unalloyed steel	approx. 0,15 % C	annealed	125	1										
		approx. 0,45 % C	annealed	190	2										
		approx. 0,45 % C	tempered	250	3										
		approx. 0,75 % C	annealed	270	4										
		approx. 0,75 % C	tempered	300	5										
	Low-alloyed steel		annealed	180	6										
			tempered	275	7										
			tempered	300	8										
			tempered	350	9										
	High-alloyed steel and high-alloyed tool steel		annealed	200	10										
			hardened and tempered	325	11										
<b>M</b>	Stainless steel	ferritic/martensitic	annealed	200	12							360	290	200	
		martensitic	tempered	240	13							180	150	110	
		austenitic	quench hardened	180	14							240	190	140	
		austenitic-ferritic		230	15							190	150	110	
<b>K</b>	Grey cast iron	perlitic/ferritic		180	16	570	395	220							
		perlitic (martensitic)		260	17	310	230	150							
	Cast iron with spheroidal graphite	ferritic		160	18	310	230	150							
		perlitic		250	19	230	170	110							
	Malleable cast iron	ferritic		130	20	340	280	220							
		perlitic		230	21	250	180	110							
<b>N</b>	Aluminium wrought alloys	cannot be hardened		60	22				2000	1200	-	2000	1200	-	
		hardenable	hardened	100	23				610	420	-	610	420	-	
	Cast aluminium alloys	$\leq 12\%$ Si, cannot be hardened		75	24				550	300	-	550	300	-	
		$\leq 12\%$ Si, hardenable	hardened	90	25				360	190	-	360	190	-	
		$> 12\%$ Si, cannot be hardened		130	26				320	170	-	320	170	-	
	Copper and copper alloys (bronze/brass)	machining steel, PB > 1%			110	27				730	350	-	730	350	-
		CuZn, CuSnZn			90	28				370	330	-	370	330	-
		CuSn, Pb-free copper, electrolytic copper			100	29				270	200	-	270	200	-
<b>S</b>	Heat-resistant alloys	Fe-based alloys	annealed	200	30							65	45	-	
			hardened	280	31							60	40	-	
		Ni or Co base	annealed	250	32							60	40	-	
			hardened	350	33							55	35	-	
	cast	320	34							55	35	-			
Titanium alloys	pure titanium		R <sub>m</sub> 400	35							100	60	-		
$\alpha$ and $\beta$ alloys	hardened		R <sub>m</sub> 1050	36							80	40	-		
<b>H</b>	Hardened steel		hardened and tempered	55 HRC	37										
			hardened and tempered	60 HRC	38										
	Hard cast iron		cast	400	39										
	Hardened cast iron		hardened and tempered	55 HRC	40										
<b>X</b>	Non-metallic materials	Thermoplastics			41										
		Thermosetting plastics			42										
		Plastic, glass-fibre reinforced GFRP			43										
		Plastic, carbon fibre reinforced CFRP			44										
		Graphite			45										
		Wood			46										

Note: The given cutting values are guide values, which were determined under ideal conditions. The values have to be adapted in individual cases. For examples of material for cutting tool groups view page D11.



## Turning insert, negative

Material group	Composition / structure / heat treatment		Brinell hardness HB	Machining group	Starting values for cutting speed $v_c$ [m/min]									
					HW						BL			
					YD101			YD201			YCB112			
					Feed rate [mm]			Feed rate [mm]			Feed rate [mm]			
	0,05	0,2	0,35	0,1	0,2	0,3	0,1	0,2	0,3					
<b>P</b> Unalloyed steel	approx. 0,15 % C	annealed	125	1										
	approx. 0,45 % C	annealed	190	2										
	approx. 0,45 % C	tempered	250	3										
	approx. 0,75 % C	annealed	270	4										
	approx. 0,75 % C	tempered	300	5										
<b>P</b> Low-alloyed steel		annealed	180	6										
		tempered	275	7										
		tempered	300	8										
		tempered	350	9										
High-alloyed steel and high-alloyed tool steel		annealed	200	10										
		hardened and tempered	325	11										
<b>M</b> Stainless steel	ferritic/martensitic	annealed	200	12										
	martensitic	tempered	240	13										
	austenitic	quench hardened	180	14										
	austenitic-ferritic		230	15										
Grey cast iron	perlitic/ferritic		180	16										
	perlitic (martensitic)		260	17										
Cast iron with spheroidal graphite	ferritic		160	18										
	perlitic		250	19										
Malleable cast iron	ferritic		130	20										
	perlitic		230	21										
<b>N</b> Aluminium wrought alloys	cannot be hardened		60	22	1750	1200	800	1750	1200	800				
	hardenable	hardened	100	23	510	380	250	510	380	250				
	≤ 12% Si, cannot be hardened		75	24	460	320	175	460	320	175				
	≤ 12% Si, hardenable	hardened	90	25	300	205	110	300	205	110				
Cast aluminium alloys	> 12% Si, cannot be hardened		130	26	270	185	100	270	185	100				
	machining steel, PB> 1%		110	27	610	410	205	610	410	205				
Copper and copper alloys (bronze/brass)	CuZn, CuSnZn		90	28	310	250	195	310	250	195				
	CuSn, Pb-free copper, electrolytic copper		100	29	225	170	115	225	170	115				
<b>S</b> Heat-resistant alloys	Fe-based alloys	annealed	200	30										
		hardened	280	31										
	Ni or Co bass	annealed	250	32							180	160	140	
		hardened	350	33							160	140	120	
Titanium alloys	cast	320	34							120	100	80		
	pure titanium		R <sub>m</sub> 400	35										
	α and β alloys	hardened	R <sub>m</sub> 1050	36										
<b>H</b> Hardened steel		hardened and tempered	55 HRC	37							220	170	130	
		hardened and tempered	60 HRC	38							200	160	120	
Hard cast iron		cast	400	39							200	150	100	
Hardened cast iron		hardened and tempered	55 HRC	40							200	150	100	
<b>X</b> Non-metallic materials	Thermoplastics			41										
	Thermosetting plastics			42										
	Plastic, glass-fibre reinforced GFRP			43										
	Plastic, carbon fibre reinforced CFRP			44										
	Graphite			45										
	Wood			46										

Note: The given cutting values are guide values, which were determined under ideal conditions. The values have to be adapted in individual cases. For examples of material for cutting tool groups view page D11.



## Turning insert, negative

	Material group	Composition / structure / heat treatment		Brinell hardness HB	Machining group	Starting values for cutting speed $v_c$ [m/min]									
						BC			BH			CM			
						YZB630C			YZB233			CA1000			
						Feed rate [mm]			Feed rate [mm]			Feed rate [mm]			
		0,1	0,3	0,5	0,3	0,9	1,5	0,1	0,6	1,5					
<b>P</b>	Unalloyed steel	approx. 0,15 % C	annealed	125	1										
		approx. 0,45 % C	annealed	190	2										
		approx. 0,45 % C	tempered	250	3										
		approx. 0,75 % C	annealed	270	4										
		approx. 0,75 % C	tempered	300	5										
	Low-alloyed steel		annealed	180	6										
			tempered	275	7										
			tempered	300	8										
			tempered	350	9										
	High-alloyed steel and high-alloyed tool steel		annealed	200	10										
			hardened and tempered	325	11										
<b>M</b>	Stainless steel	ferritic/martensitic	annealed	200	12										
		martensitic	tempered	240	13										
		austenitic	quench hardened	180	14										
		austenitic-ferritic		230	15										
<b>K</b>	Grey cast iron	perlitic/ferritic		180	16				1500	950	400				
		perlitic (martensitic)		260	17				1250	780	320				
	Cast iron with spheroidal graphite	ferritic		160	18				-	-	-				
		perlitic		250	19				500	300	100				
	Malleable cast iron	ferritic		130	20				-	-	-				
		perlitic		230	21				500	300	100				
<b>N</b>	Aluminium wrought alloys	cannot be hardened		60	22										
		hardenable	hardened	100	23										
	Cast aluminium alloys	$\leq 12\%$ Si, cannot be hardened		75	24										
		$\leq 12\%$ Si, hardenable	hardened	90	25										
		$> 12\%$ Si, cannot be hardened		130	26										
	Copper and copper alloys (bronze/brass)	machining steel, PB > 1%			110	27									
		CuZn, CuSnZn			90	28									
		CuSn, Pb-free copper, electrolytic copper			100	29									
<b>S</b>	Heat-resistant alloys	Fe-based alloys	annealed	200	30										
			hardened	280	31										
		Ni or Co base	annealed	250	32										
			hardened	350	33										
	Titanium alloys			$R_m$ 400	35										
				$R_m$ 1050	36										
<b>H</b>	Hardened steel		hardened and tempered	55 HRC	37	220	170	130				180	150	120	
			hardened and tempered	60 HRC	38	200	160	120				140	120	80	
	Hard cast iron		cast	400	39	200	150	100				80	60	40	
	Hardened cast iron		hardened and tempered	55 HRC	40	200	150	100				-	-	-	
<b>X</b>	Non-metallic materials	Thermoplastics			41										
		Thermosetting plastics			42										
		Plastic, glass-fibre reinforced GFRP			43										
		Plastic, carbon fibre reinforced CFRP			44										
		Graphite			45										
		Wood			46										

Note: The given cutting values are guide values, which were determined under ideal conditions.  
 The values have to be adapted in individual cases.  
 For examples of material for cutting tool groups view page D11.

**A**

Turning

**B**

Milling

**C**

Drilling

**D**

Technical Information

**E**

Index



## Turning insert, positive

	Material group	Composition / structure / heat treatment		Brinell hardness HB	Machining group	Starting values for cutting speed $v_c$ [m/min]									
						HC (CVD)									
						YBC103			YB6315			YBC152			
						Feed rate [mm]			Feed rate [mm]			Feed rate [mm]			
					0,1	0,2	0,4	0,1	0,2	0,4	0,1	0,2	0,4		
<b>P</b>	Unalloyed steel	approx. 0,15 % C	annealed	125	1	460	400	280	450	390	270	450	390	270	
		approx. 0,45 % C	annealed	190	2	390	340	240	380	330	230	380	330	230	
		approx. 0,45 % C	tempered	250	3	310	275	210	300	265	200	300	265	200	
		approx. 0,75 % C	annealed	270	4	300	265	200	290	255	190	290	255	190	
		approx. 0,75 % C	tempered	300	5	260	235	180	250	225	170	250	225	170	
	Low-alloyed steel			annealed	180	6	370	310	190	360	300	180	360	300	180
				tempered	275	7	260	220	160	250	210	150	250	210	150
				tempered	300	8	240	210	160	230	200	150	230	200	150
				tempered	350	9	210	180	130	200	170	120	200	170	120
		High-alloyed steel and high-alloyed tool steel			annealed	200	10	330	285	200	320	275	190	320	275
			hardened and tempered	325	11	170	160	140	160	150	130	160	150	130	
<b>M</b>	Stainless steel	ferritic/martensitic	annealed	200	12										
			martensitic	tempered	240	13									
			austenitic	quench hardened	180	14									
			austenitic-ferritic		230	15									
<b>K</b>	Grey cast iron	perlitic/ferritic		180	16										
		perlitic (martensitic)		260	17										
	Cast iron with spheroidal graphite	ferritic		160	18										
		perlitic		250	19										
	Malleable cast iron	ferritic		130	20										
		perlitic		230	21										
<b>N</b>	Aluminium wrought alloys	cannot be hardened		60	22										
		hardenable	hardened	100	23										
	Cast aluminium alloys	$\leq 12\%$ Si, cannot be hardened		75	24										
		$\leq 12\%$ Si, hardenable	hardened	90	25										
		$> 12\%$ Si, cannot be hardened		130	26										
	Copper and copper alloys (bronze/brass)	machining steel, PB > 1%		110	27										
		CuZn, CuSnZn		90	28										
	CuSn, Pb-free copper, electrolytic copper		100	29											
<b>S</b>	Heat-resistant alloys	Fe-based alloys	annealed	200	30										
			hardened	280	31										
		Ni or Co bass	annealed	250	32										
			hardened	350	33										
		cast	320	34											
Titanium alloys	pure titanium		R <sub>m</sub> 400	35											
	$\alpha$ and $\beta$ alloys	hardened	R <sub>m</sub> 1050	36											
<b>H</b>	Hardened steel		hardened and tempered	55 HRC	37										
			hardened and tempered	60 HRC	38										
	Hard cast iron		cast	400	39										
	Hardened cast iron		hardened and tempered	55 HRC	40										
<b>X</b>	Non-metallic materials	Thermoplastics			41										
		Thermosetting plastics			42										
		Plastic, glass-fibre reinforced GFRP			43										
		Plastic, carbon fibre reinforced CFRP			44										
		Graphite			45										
		Wood			46										

Note: The given cutting values are guide values, which were determined under ideal conditions.  
 The values have to be adapted in individual cases.  
 For examples of material for cutting tool groups view page D11.

**A**  
 Turning  
**B**  
 Milling  
**C**  
 Drilling  
**D**  
 Technical Information  
**E**  
 Index

Starting values for cutting speed $v_c$ [m/min]																							
HC (CVD)																							
YBC203			YBC252			YBC352			YBM153			YBM253			YBD102			YB7315			YBD152		
Feed rate [mm]			Feed rate [mm]			Feed rate [mm]			Feed rate [mm]			Feed rate [mm]			Feed rate [mm]			Feed rate [mm]			Feed rate [mm]		
0,1	0,3	0,6	0,1	0,3	0,6	0,2	0,4	0,6	0,1	0,2	0,4	0,1	0,2	0,4	0,1	0,2	0,4	0,1	0,2	0,4	0,1	0,2	0,4
430	350	230	430	350	230	390	310	230															
360	295	190	360	295	190	315	250	190															
280	235	160	280	235	160	230	195	160															
270	225	150	270	225	150	220	185	150															
235	195	130	235	195	130	185	155	120															
340	270	170	340	270	170	290	225	150															
235	195	140	235	195	140	170	150	130															
220	180	140	220	180	140	150	140	130															
190	155	110	190	155	110	130	110	90															
280	230	170	280	230	170	180	160	140															
130	115	100	130	115	100	–	–	–															
									360	340	260	330	300	230									
									180	170	140	150	130	95									
									240	220	170	195	170	115									
									190	175	140	160	140	100									
															480	345	200	540	370	200	490	340	190
															220	180	135	300	220	135	250	190	130
															270	210	130	300	230	145	260	200	125
															200	150	95	230	180	110	190	140	90
															275	240	180	310	260	190	265	230	170
															190	145	85	230	170	100	190	140	90

- HC Coated carbide
- HT Uncoated carbide, primary component (TiC) or (TiN), cermet
- HW Uncoated carbide, primary component (WC)
- BL Cubic boron nitride with low BN content
- BH Cubic boron nitride with high BN content
- CN Si3N4 ceramic
- CM Mixed ceramic
- HC<sub>1</sub> Coated cermet
- BC CBN with coating
- CC Coated cutting ceramic
- CR Cutting ceramic, primary component aluminium oxide (Al<sub>2</sub>O<sub>3</sub>), reinforced
- DP Polycrystalline diamond



A  
Turning  
B  
Milling  
C  
Drilling  
D  
Technical Information  
E  
Index



## Turning insert, positive

	Material group	Composition / structure / heat treatment		Brinell hardness HB	Machining group	Starting values for cutting speed $v_c$ [m/min]									
						HC (CVD)			HC (PVD)						
						YBD152C			YBG101			YBG102			
						Feed rate [mm]			Feed rate [mm]			Feed rate [mm]			
				0,1	0,2	0,4	0,1	0,2	0,4	0,1	0,2	0,4			
<b>P</b>	Unalloyed steel	approx. 0,15 % C	annealed	125	1										
		approx. 0,45 % C	annealed	190	2										
		approx. 0,45 % C	tempered	250	3										
		approx. 0,75 % C	annealed	270	4										
		approx. 0,75 % C	tempered	300	5										
	Low-alloyed steel		annealed	180	6										
			tempered	275	7										
			tempered	300	8										
			tempered	350	9										
	High-alloyed steel and high-alloyed tool steel		annealed	200	10										
			hardened and tempered	325	11										
<b>M</b>	Stainless steel	ferritic/martensitic	annealed	200	12						305	245	205		
		martensitic	tempered	240	13						150	125	100		
		austenitic	quench hardened	180	14						200	165	145		
		austenitic-ferritic		230	15						160	130	115		
<b>K</b>	Grey cast iron	perlitic/ferritic		180	16	520	360	200							
		perlitic (martensitic)		260	17	280	210	135							
	Cast iron with spheroidal graphite	ferritic		160	18	280	220	135							
		perlitic		250	19	210	160	100							
	Malleable cast iron	ferritic		130	20	280	245	180							
		perlitic		230	21	210	160	100							
<b>N</b>	Aluminium wrought alloys	cannot be hardened		60	22				1800	880	-	1800	880	-	
		hardenable	hardened	100	23				540	380	-	540	380	-	
	Cast aluminium alloys	$\leq 12\%$ Si, cannot be hardened		75	24				500	270	-	500	270	-	
		$\leq 12\%$ Si, hardenable	hardened	90	25				320	170	-	320	170	-	
		$> 12\%$ Si, cannot be hardened		130	26				290	150	-	290	150	-	
	Copper and copper alloys (bronze/brass)	machining steel, PB > 1%		110	27				660	320	-	660	320	-	
		CuZn, CuSnZn		90	28				330	300	-	330	300	-	
	CuSn, Pb-free copper, electrolytic copper		100	29				220	175	-	220	175	-		
<b>S</b>	Heat-resistant alloys	Fe-based alloys	annealed	200	30							60	45	-	
			hardened	280	31								55	40	-
		Ni or Co bass	annealed	250	32								55	40	-
			hardened	350	33								50	35	-
		cast	320	34								50	35	-	
Titanium alloys	pure titanium		R <sub>m</sub> 400	35							95	60	-		
	$\alpha$ and $\beta$ alloys	hardened	R <sub>m</sub> 1050	36							75	40	-		
<b>H</b>	Hardened steel		hardened and tempered	55 HRC	37										
			hardened and tempered	60 HRC	38										
	Hard cast iron		cast	400	39										
	Hardened cast iron		hardened and tempered	55 HRC	40										
<b>X</b>	Non-metallic materials	Thermoplastics			41										
		Thermosetting plastics			42										
		Plastic, glass-fibre reinforced GFRP			43										
		Plastic, carbon fibre reinforced CFRP			44										
		Graphite			45										
		Wood			46										

Note: The given cutting values are guide values, which were determined under ideal conditions.  
 The values have to be adapted in individual cases.  
 For examples of material for cutting tool groups view page D11.

**A** Turning  
**B** Milling  
**C** Drilling  
**D** Technical Information  
**E** Index



## Turning insert, positive

	Material group	Composition / structure / heat treatment		Brinell hardness HB	Machining group	Starting values for cutting speed $v_c$ [m/min]									
						HW						BL			
						YD101			YD201			YCB112			
						Feed rate [mm]			Feed rate [mm]			Feed rate [mm]			
					0,1	0,2	0,3	0,1	0,2	0,3	0,1	0,2	0,3		
<b>P</b>	Unalloyed steel	approx. 0,15 % C	annealed	125	1										
		approx. 0,45 % C	annealed	190	2										
		approx. 0,45 % C	tempered	250	3										
		approx. 0,75 % C	annealed	270	4										
		approx. 0,75 % C	tempered	300	5										
	Low-alloyed steel		annealed	180	6										
			tempered	275	7										
			tempered	300	8										
			tempered	350	9										
	High-alloyed steel and high-alloyed tool steel		annealed	200	10										
			hardened and tempered	325	11										
<b>M</b>	Stainless steel	ferritic/martensitic	annealed	200	12										
		martensitic	tempered	240	13										
		austenitic	quench hardened	180	14										
		austenitic-ferritic		230	15										
<b>K</b>	Grey cast iron	perlitic/ferritic		180	16										
		perlitic (martensitic)		260	17										
	Cast iron with spheroidal graphite	ferritic		160	18										
		perlitic		250	19										
	Malleable cast iron	ferritic		130	20										
		perlitic		230	21										
<b>N</b>	Aluminium wrought alloys	cannot be hardened		60	22	1550	1050	700	1550	1050	700				
		hardenable	hardened	100	23	450	320	200	450	320	200				
	Cast aluminium alloys	$\leq 12\% \text{ Si}$ , cannot be hardened		75	24	400	270	150	400	270	150				
		$\leq 12\% \text{ Si}$ , hardenable	hardened	90	25	250	170	95	250	170	95				
		$> 12\% \text{ Si}$ , cannot be hardened		130	26	230	150	85	230	150	85				
	Copper and copper alloys (bronze/brass)	machining steel, PB > 1%			110	27	550	370	170	550	370	170			
		CuZn, CuSnZn			90	28	260	210	160	260	210	160			
CuSn, Pb-free copper, electrolytic copper			100	29	190	145	95	190	145	95					
<b>S</b>	Heat-resistant alloys	Fe-based alloys	annealed	200	30	55	30	-	55	30	-	-	-	-	
			hardened	280	31	55	25	-	55	25	-	-	-	-	
		Ni or Co base	annealed	250	32	45	25	-	45	25	-	180	160	140	
			hardened	350	33	35	20	-	35	20	-	160	140	120	
	cast	320	34	40	20	-	40	20	-	120	100	80			
Titanium alloys	pure titanium		R <sub>m</sub> 400	35	60	40	-	60	40	-	-	-	-		
	$\alpha$ and $\beta$ alloys	hardened	R <sub>m</sub> 1050	36	30	-	-	30	-	-	-	-	-		
<b>H</b>	Hardened steel		hardened and tempered	55 HRC	37							220	170	130	
			hardened and tempered	60 HRC	38							200	160	120	
	Hard cast iron		cast	400	39							200	150	100	
	Hardened cast iron		hardened and tempered	55 HRC	40							200	150	100	
<b>X</b>	Non-metallic materials	Thermoplastics			41										
		Thermosetting plastics			42										
		Plastic, glass-fibre reinforced GFRP			43										
		Plastic, carbon fibre reinforced CFRP			44										
		Graphite			45										
		Wood			46										

Note: The given cutting values are guide values, which were determined under ideal conditions. The values have to be adapted in individual cases. For examples of material for cutting tool groups view page D11.

**A** Turning  
**B** Milling  
**C** Drilling  
**D** Technical Information  
**E** Index



# PARTING & GROOVING

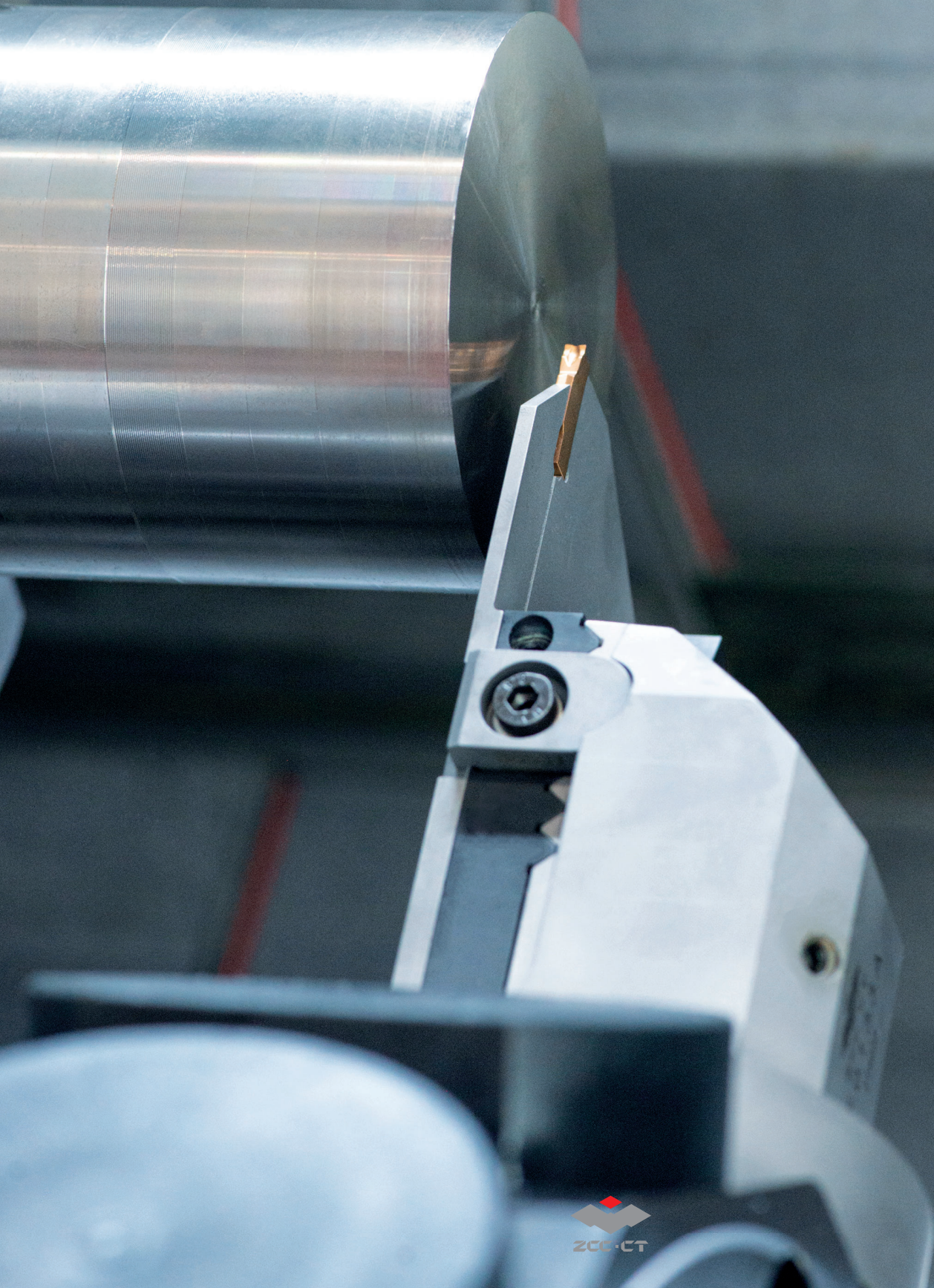

**A**

Turning

**B**

Milling

**C**

Drilling

**D**Technical  
Information**E**

Index



## Parting & grooving

Product overview	A382-A383
System overview	A384-A385
Tool holder orientation	A386-A387
Chip breaker overview	A388-A389
Application fields of chip breakers	A390-A391
Grade overview	A392-A393
Application fields of grades	A394-A397
System code – inserts	A398
Inserts	A399-A415
System code – inserts – QC series	A416
Inserts – QC series	A417-A421
System code – tool holders	A422-A424
Tool holders	A425-A445
Precision monoblock tool holder	A446-A451
System code – tool holders – QC series	A452
Tool holders – QC series	A453-A455
Recommended cutting data	A456-A457
Technical Information	A510
Special tools	A513

## Parting & grooving inserts

### Double sided



**ZT\*D-MM**

2-8

A399



**ZT\*D-MG**

2.5-6

A404



**ZT\*\*-EG**

1-6.5

A407

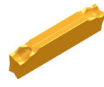

**ZP\*D-MG**

2.5-6

A400



**ZP\*D-MG-R/L**

2.35-2.85

A401

Width

Page



**ZR\*D-MG**

2.5-6

A410



**ZR\*D-EG**

3-6

A411



**ZR\*D-LH**

6-8

A414



**ZILD-LC**

8

A415

Width

Page

### Single sided



**ZT\*S-MM**

2.5-6

A406



**ZT\*S-MG**

5-6

A405



**ZP\*S-MG**

2.5-6

A402



**ZP\*S-MG-R/L**

2.5-3

A403



**ZIMF-NM**

3-6

A412



**ZIGQ-NM**

3-6

A413

Width

Page

### Three cutting edges



**QC\*\*R/L**

0.75-4.8

A417



**QC\*\*R/L\*\*\*R**

1-4

A420

Width

Page

A

Turning

B

Milling

C

Drilling

D

Technical Information

E

Index

## External tool holders

						
<b>GQC**R/L</b>	<b>QE**R/L</b>	<b>QE*S**N</b>	<b>QE*S**N-1</b>	<b>QE*SN30</b>	<b>QE*SR/L</b>	<b>QECDR/L</b>
A453	A425	A431	A432	A427	A430	A428

						
<b>QF**R/L</b>	<b>QF**RR/LL</b>	<b>QF*DR/L</b>	<b>QF*SRR/LL</b>	<b>QFHSDR/L</b>	<b>QX*DR/L</b>	<b>QZS*</b>
A434	A436	A439	A438	A441	A429	A433

		
<b>QE**R/L-DGC</b>	<b>QE**R/L-DGSC</b>	<b>QE**R/L-SC</b>
A446	A448	A449

## Boring bars

		
<b>C***-Q*DR/L</b>	<b>C40X-Q*DR/L</b>	<b>S*K-QC**R/L</b>
A444	A443	A454

**A**

Turning

**B**

Milling

**C**

Drilling

**D**

Technical  
Information

**E**

Index



**A**

Turning

**B**

Milling

**C**

Drilling

**D**

Technical Information

**E**

Index

	System information	Groove width S	Groove depth a, max.	Grooving	Parting	Turning	Page
QE system	<ul style="list-style-type: none"> <li>System for <b>radial parting off and grooving</b> and <b>turning</b></li> <li>Tool holders available for internal and external machining</li> <li>Available with targeted cooling and direct supply of coolant via the shank</li> <li>Inserts with one or two cutting edges</li> <li>Inserts for precision grooving available</li> </ul>	2,0–6,0 mm	max 30,0 mm	✓	✓	✓	<ul style="list-style-type: none"> <li>■ A425</li> <li>● A444</li> </ul>
QZ and QE system	<ul style="list-style-type: none"> <li>System for <b>radial parting off and grooving</b></li> <li>Insert holder and clamping block in one</li> <li>Self-clamping system</li> <li>Inserts with one cutting edge</li> <li>Can be used in a wide range of applications</li> </ul>	2,5–6,0 mm	max 60,0 mm	✓	✓	–	■ A431
QF system	<ul style="list-style-type: none"> <li>System for radial <b>grooving and turning</b></li> <li>Penetration diameter range of Ø 48–400 mm</li> <li>Screw clamped for maximum stability</li> <li>Inserts with two cutting edges</li> <li>Tool holders available in a neutral design or with a 90° offset</li> <li>Right base for M3</li> <li>Left base for M4</li> </ul>	2,0–6,0 mm	max 22,0 mm	✓	–	✓	■ A434
QX system	<ul style="list-style-type: none"> <li>System for <b>undercutting</b></li> <li>Shank holder with 45° approach angle</li> <li>Screw clamped for maximum stability</li> <li>For grooving inserts with two cutting edges</li> <li>For turning operations and machining undercuts and recesses. Can also be used in copy turning applications</li> </ul>	3,0–6,0 mm	max 4,0 mm	✓	–	✓	■ A429

■ External tool holders  
● Boring bars

	System information	Groove width S	Groove depth a, max.	Grooving	Parting	Turning	Page
<b>C*X-Q system</b>	<ul style="list-style-type: none"> <li>Special system for <b>machining aluminium wheels</b></li> <li>Boring bar with 15° approach angle</li> <li>Screw clamped for maximum stability</li> <li>For grooving inserts with two cutting edges</li> <li>Penetration diameter range from Ø 160 mm</li> <li>Special chip breakers for aluminium machining</li> </ul>	6,0–8,0 mm	max 80,0 mm	–	–	✓	● A443
<b>QE*S*N system</b>	<ul style="list-style-type: none"> <li>System specially designed for <b>heat-resistant alloys</b></li> <li>Special chip breakers for heat-resistant alloys</li> <li>Screw clamped for maximum stability</li> <li>For grooving inserts with one cutting edge</li> </ul>	3,0–6,0 mm	max 22,0 mm	✓	–	✓	■ A430
<b>QC system</b>	<ul style="list-style-type: none"> <li>System for <b>precision grooving</b></li> <li>Tool holders available for external and internal machining</li> <li>Tangential screw clamping for high stability and rigidity</li> <li>Three cutting edges for high efficiency</li> <li>Precision-ground grooving inserts with high tolerances</li> <li>High repeatability even after replacing insert</li> <li>Grooving inserts with straight or round cutting edge</li> <li>Special feature with internal machining: right tool holder + left grooving insert / left tool holder + right grooving insert</li> </ul>	0,5–4,8 mm	max 5,0 mm	✓	–	–	■ A453 ● A454

■ External tool holders  
● Boring bars

A

Turning

B

Milling

C

Drilling

D

Technical Information

E

Index

## Tool holders for axial machining

Tool holder	Tool holder orientation
<p><b>A</b></p> <p>Turning</p> <p>QFFD****L**_**H</p>	 <p>CW/M3</p>
<p><b>B</b></p> <p>Milling</p> <p>QFFD****R**_**H</p>	 <p>CCW/M4</p>
<p><b>C</b></p> <p>Drilling</p> <p>QFFD****LL**_**H</p>	 <p>CCW/M4</p>
<p><b>D</b></p> <p>Technical Information</p> <p>QFFD****L**_**L</p>	 <p>CCW/M4</p>
<p><b>E</b></p> <p>Index</p> <p>QFFD****R**_**L</p>	 <p>CW/M3</p>

Notes

Dotted lines for notes

<b>A</b>
Turning
<b>B</b>
Milling
<b>C</b>
Drilling
<b>D</b>
Technical Information
<b>E</b>
Index

**A**

## Grooving

MM P M K S



Turning

Sintered chip breaker with straight cutting edge for general machining of steel, stainless steel, cast iron and difficult-to-machine materials. Can be used for grooving, turning and parting off.

**B**

MG P M K S

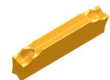

Milling

Sintered chip breaker for general machining of steel, stainless steel, cast iron and difficult-to-machine materials. Can be used for grooving, turning and parting off.

**C**

MG P M K S



Drilling

Universal chip breaker with round profile for general machining of steel, stainless steel and cast iron. Suitable for grooving and profiling.

**D**

EG M P S



Technical Information

Ground precision chip breaker for grooving and turning applications. Suitable for machining of stainless steel. E-tolerance for high repeatability.

EG M P S



Ground precision chip breaker with round profile for grooving and turning applications. Suitable for machining of stainless steel. E-tolerance for high repeatability.

**E**

NM S

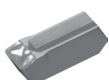

Index

Special chip breaker for machining of heat-resistant materials.

## Grooving

LC

N



Ground chip breaker for profile and turning applications of non-ferrous metals.

LH

N



Ground chip breaker for profile and turning applications of non-ferrous metals.

A

Turning

B

Milling

C

Drilling

D

Technical Information

E

Index

# Parting & grooving Application fields of chip breakers

**A**  
 Turning  
**B**  
 Milling  
**C**  
 Drilling  
**D**  
 Technical Information  
**E**  
 Index

Chip breaker	Application	P	M	K	N	S	H	Feed	Cutting edge design
ZT****-MM	Parting & grooving ✓								
	Turning ✓	✓	✓	✓		✓			
ZP****-MG	Parting & grooving ✓								
	Turning -	✓	✓	✓		✓			
ZT****-MG	Parting & grooving ✓								
	Turning ✓	✓	✓	✓		✓			
ZR****-MG	Parting & grooving ✓								
	Turning ✓	✓	✓	✓		✓			
ZT****-EG	Parting & grooving ✓								
	Turning ✓	✓	✓	✓		✓			
ZR****-EG	Parting & grooving ✓								
	Turning ✓	✓	✓	✓		✓			
ZI****-NM	Parting & grooving ✓								
	Turning ✓		✓		✓	✓			

✓ Very suitable    ✓ Suitable

Parting & grooving  
 Turning

Chip breaker	Application	P	M	K	N	S	H	Feed	Cutting edge design
ZR****-LH	Parting & grooving ✓				✓	✓			Round profile 
	Turning ✓								
ZI****-LC	Parting & grooving ✓				✓	✓			Round profile 
	Turning ✓								

✓ Very suitable

✓ Suitable

■ Parting & grooving

■ Turning

<b>A</b>	Turning
<b>B</b>	Milling
<b>C</b>	Drilling
<b>D</b>	Technical Information
<b>E</b>	Index



**A**  
Turning

**B**  
Milling

**C**  
Drilling

**D**  
Technical Information

**E**  
Index

## Parting & grooving

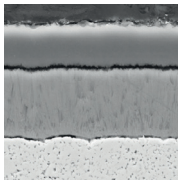
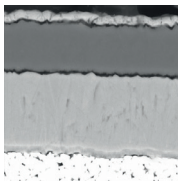
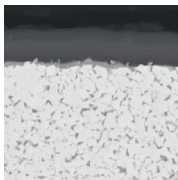
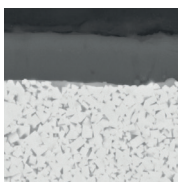
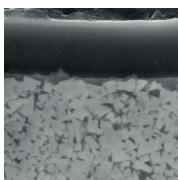
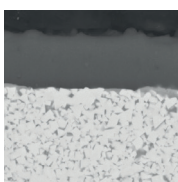
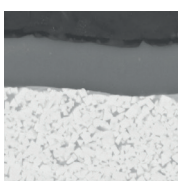
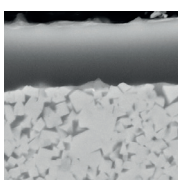
Grade	ISO	Micro structure	Grade description
<b>YBC252</b>	P20 - P35		CVD coated P20–P35 carbide grade for medium operation to roughing of steel and casting steel. Optimal performance of wear resistance and toughness for a wide application field.
<b>YBC251</b>	P20 - P35		CVD coated P20–P35 carbide grade for medium operation to roughing of steel and casting steel in lower cutting speed.
<b>YBG105</b>	S05 - S20		PVD multilayer coated S05–S20 carbide substrate for finishing to medium application of super alloy material but also stainless steel. Good wear resistance and thermal stability in a wide application field.
<b>YBG102</b>	S05 - S15		PVD coated S05–S15 carbide substrate for finishing to medium application of super alloy material, stainless steel and aluminum. Good wear resistance in a wide application field.
<b>YB9320</b>	P10 - P30 M10 - M25		PVD multilayer coated P10–P30/M10–M25 carbide substrate for finishing to medium machining of stainless steel, super alloys and steel (grooving/milling). Optimised coating stability for higher wear resistance and thermal stability in a wide range of applications.
<b>YBG205</b>	P10 - P30 M20 - M40 S15-S25		PVD multilayer coated P10–P30/M20–M40/S15–S25 carbide substrate for finishing to medium machining of stainless steel, super alloys and steel (milling). Excellent wear resistance and thermal stability in a wide range of applications.
<b>YBG202</b>	P10 - P30 M10 - M25		PVD coated P10–P30/M10–M25 carbide substrate for finishing to medium application of stainless steel and steel (milling). Good wear resistance in a wide application field.
<b>YBG302</b>	P15 - P30 M25 - M40		PVD coated P15–P30/M25–M40 carbide substrate for medium roughing application of stainless steel and steel (milling). Good wear resistance and toughness.

**Parting & grooving**

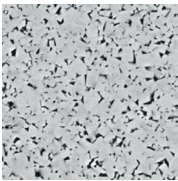
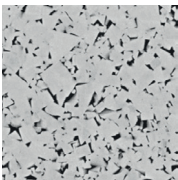
Grade	ISO	Micro structure	Grade description
<b>YD101</b>	K05 - K20 N05 - N20		Uncoated K05–K20/N05–N20 carbide substrate for fine to medium application in aluminum and other material.
<b>YD201</b>	K10 - K30 N10 - N30		Uncoated K10–K30/N10–N30 carbide substrate for medium application in aluminum and other material.

**A**

Turning

**B**

Milling

**C**

Drilling

**D**Technical  
Information**E**

Index

## CVD coated carbide grades for steel

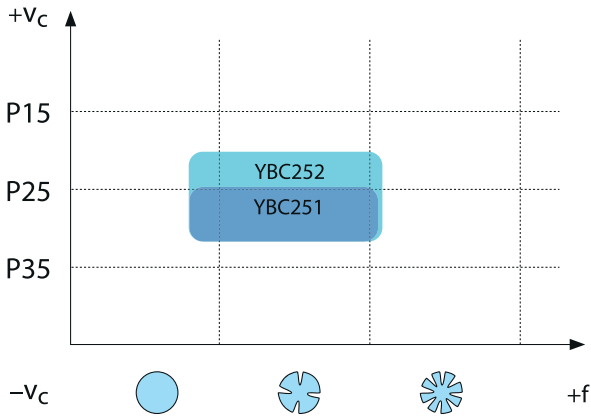

## PVD coated carbide grades for stainless steel

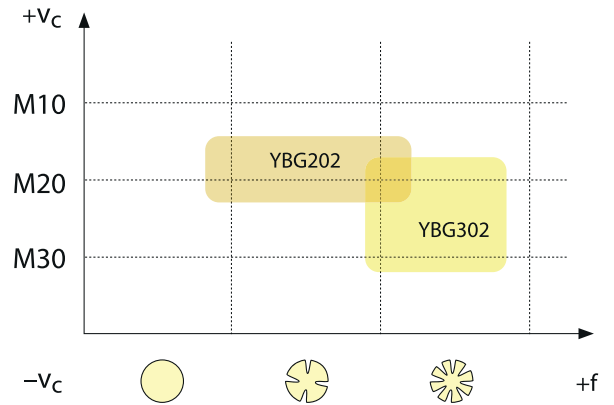
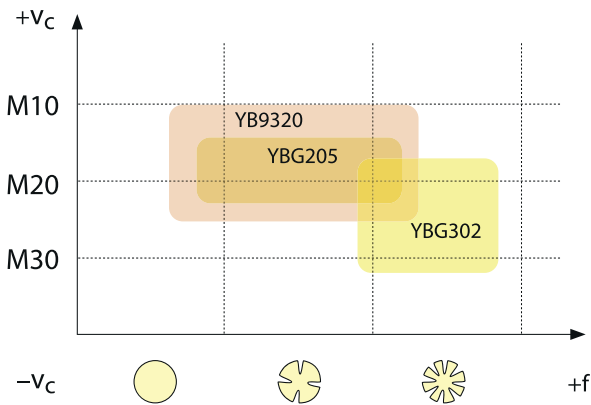

## PVD coated carbide grades for superalloys

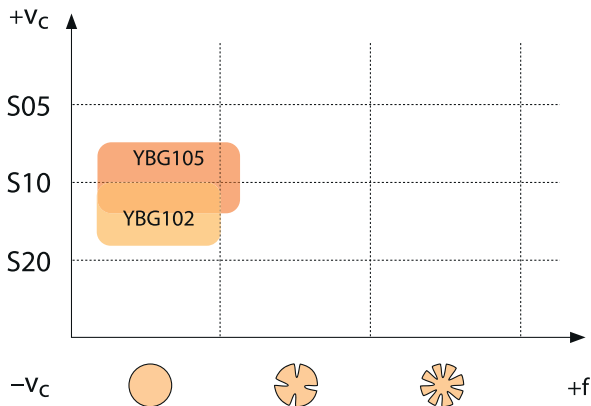

**A**

Turning

**B**

Milling

**C**

Drilling

**D**

Technical Information

**E**

Index

**Carbide grades for non-ferrous metals**

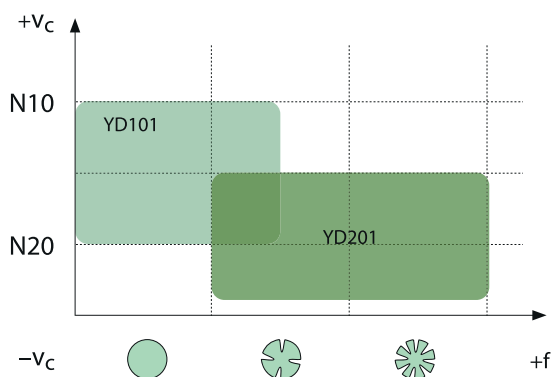

**A**

Turning

**B**

Milling

**C**

Drilling

**D**

Technical  
Information

**E**

Index

## Application fields of grades – parting & grooving

	ISO	HC <sup>1</sup> (CVD)	HC <sup>1</sup> (PVD)	HT	HC <sup>2</sup>	Ceramic	HW	CBN	PCD
<b>A</b> Turning	P01								
	P10	YBC251 YBC252							
	P20								
	P30								
	P40								
<b>B</b> Milling	M01								
	M10		YBG202 YBG205 YB9320 YBG302						
	M20								
	M30								
	M40								
<b>C</b> Drilling	K01								
	K10								
	K20								
	K30								
<b>D</b> Technical Information	N01						YD101 YD102		
	N10								
	N20								
	N30								
<b>E</b> Index	S01								
	S10		YBG102 YBG105						
	S20								
	S30								
H01									
	H10								
	H20								
	H30								

<b>P</b>	Steel
<b>M</b>	Stainless steel
<b>K</b>	Cast iron

<b>N</b>	Non-ferrous metals
<b>S</b>	Heat-resistant alloys
<b>H</b>	Hardened materials

HC<sup>1</sup> Coated carbide  
 HT Uncoated cermet  
 HC<sup>2</sup> Coated cermet  
 HW Uncoated carbide

**Notes**

.....

.....

.....

.....

.....

.....

.....

.....

.....

.....

.....

.....

.....

.....

.....

.....

.....

.....

.....

.....

.....

.....

**A**

Turning

**B**

Milling

**C**

Drilling

**D**

Technical Information

**E**

Index



## ZP G D 04 04 – M G

1 2 3 4 5 6 7

A

Turning

B

Milling

C

Drilling

D

Technical Information

E

Index

Application	
Code	Description
ZP	Parting
ZT	Grooving & turning
ZR	Form turning

1

Insert seat size [mm]	
Groove width	
Code	Description
B	2,0
E	2,5
F	3,0
G	4,0
H	5,0
K	6,0
L	8,0

2

No. of cutting edges	
Code	Description
S	Single
D	Double

3

Insert thickness S [mm]	
	
Code	S
02	2,0
025	2,5
03	3,0
04	4,0
05	5,0
06	6,0
08	8,0

4

Nose radius r [mm]	
	
Code	r
02	0,2
03	0,3
04	0,4
08	0,8

5

Tolerance class [mm]	
Code	Description
M	±0,13
E	±0,025

6

Chip breaker	
Code	Description
G	General chip breaker
F	Special chip breaker
M	Straight edge

7

- Ideal machining conditions
- Normal machining conditions
- Unfavourable machining conditions

Parting inserts

ZT** parting & grooving insert (double sided)						HC <sup>1</sup> (CVD)		HC <sup>1</sup> (PVD)			HW	
<p>Double cutting edge</p>	<b>P</b>											
	<b>M</b>											
	<b>K</b>											
	<b>N</b>											
	<b>S</b>											
	<b>H</b>											
ISO	R±0.1	La max	S	f	YBC252 YBC251			YBG105 YBG102 YB9320 YBG205 YBG202 YBG302			YD101 YD201	
	<b>ZTBD02002-MM</b>	0.2	13	2	0,02-0,07					● ● ○		
	<b>ZTED02503-MM</b>	0.3	17	2.5	0,03-0,1					●		
	<b>ZTFD0303-MM</b>	0.3	17	3	0,04-0,13					●		
	<b>ZTGD0404-MM</b>	0.4	22	4	0,06-0,18					●		
	<b>ZTHD0504-MM</b>	0.4	22	5	0,08-0,23					●		
	<b>ZTKD0608-MM</b>	0.8	22	6	0,12-0,27					●		
	<b>ZTLD0808-MM</b>	0.8	28	8	0,13-0,29	○				● ○		

● Ex stock ○ On demand

HC<sup>1</sup> Coated carbide  
HW Uncoated carbide

Tool holders

QE*D*R/L	QF*D*R/L-H	QF*D*LL-H	QF*D*RR-H	QF*D*R/L-L	*-QBDR/L	C***-Q*DR/L
A425	A434	A436	A436	A439	A444	A444
QE*D*R/L-DGC	QE*D*R/L-DGSC	QE*D*R/L-SC				
A446	A448	A449				

System code > A398

Grade selection > A394

Technical info > A501

Cutting data > A456



A

Turning

B

Milling

C

Drilling

D

Technical Information

E



Index











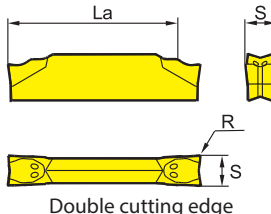



**A**

Turning

## Parting inserts

-  Ideal machining conditions
-  Normal machining conditions
-  Unfavourable machining conditions

Parting & grooving insert (double sided)						HC <sup>1</sup> (CVD)		HC <sup>1</sup> (PVD)			HW							
 <p>Double cutting edge</p>						<b>P</b>												
						<b>M</b>												
						<b>K</b>												
						<b>N</b>												
						<b>S</b>												
						<b>H</b>												
	ISO	R±0.1	La max	S±0.10	f	YBC252	YBC251		YBG105	YBG102	YB9320	YBG205	YBG202	YBG302		YD101	YD201	
	<b>ZPED02502-MG</b>	0.2	17	2.5	0,03-0,1	●				●	○	●						
	<b>ZPFD0302-MG</b>	0.2	17	3	0,04-0,13	●	●			●	○	●						
	<b>ZPGD0402-MG</b>	0.2	22	4	0,07-0,18	●				●		●					○	
	<b>ZPHD0503-MG</b>	0.3	22	5	0,1-0,24							○	●					
	<b>ZPKD0604-MG</b>	0.4	22	6	0,12-0,29	○						○	●					

● Ex stock    ○ On demand

HC<sup>1</sup> Coated carbide  
HW Uncoated carbide

**B**

Milling

**C**



Drilling

**D**

Technical Information

**E**

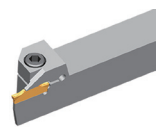
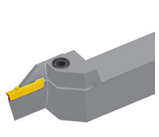
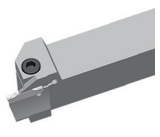
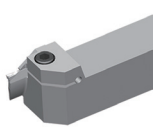
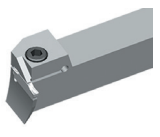
Index

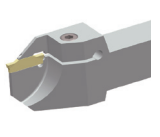
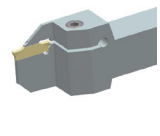
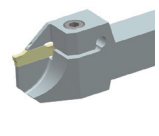
Tool holders						
<b>QE*D*R/L</b>	<b>QF*D*R/L-H</b>	<b>QF*D*RR-H</b>	<b>QF*D*LL-H</b>	<b>QF*D*R/L-L</b>	<b>C***-Q*DR/L</b>	<b>QE*D*R/L-DGC</b>
						
A425	A434	A436	A436	A439	A444	A446
<b>QE*D*R/L-DGSC</b>	<b>QE*D*R/L-SC</b>					
						
A448	A449					



System code > A398











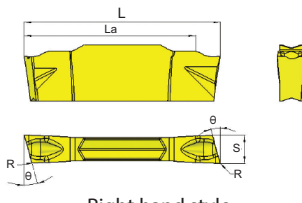





Grade selection > A394

Technical info > A501

Cutting data > A456

Parting inserts

-  Ideal machining conditions
-  Normal machining conditions
-  Unfavourable machining conditions

ZT** parting & grooving insert (double sided)								HC <sup>1</sup> (CVD)		HC <sup>1</sup> (PVD)			HW	
 <p>Right hand style</p>	<b>P</b>													
	<b>M</b>													
	<b>K</b>													
	<b>N</b>													
	<b>S</b>													
	<b>H</b>													
ISO	La max	L	S	θ	R	f	YBC252 YBC251		YBG105 YBG102	YB9320 YBG205	YBG202 YBG302	YD101 YD201		
<b>ZPED02502-MG-6L</b>	17	20	2.35	6°	0.2	0,03-0,08					●			
<b>ZPED02502-MG-6R</b>	17	20	2.35	6°	0.2	0,03-0,08				●	●			
<b>ZPED02502-MG-15L</b>	17	20	2.35	15°	0.2	0,03-0,05					○			
<b>ZPED02502-MG-15R</b>	17	20	2.35	15°	0.2	0,03-0,05					○	○		
<b>ZPFD0302-MG-6L</b>	17	20	2.85	6°	0.2	0,04-0,1				●	○	●		
<b>ZPFD0302-MG-6R</b>	17	20	2.85	6°	0.2	0,04-0,1				●	○	○		
<b>ZPFD0302-MG-15L</b>	17	20	2.85	15°	0.2	0,04-0,08					○	○		
<b>ZPFD0302-MG-15R</b>	17	20	2.85	15°	0.3	0,04-0,08				●	○			

● Ex stock ○ On demand

HC<sup>1</sup> Coated carbide  
HW Uncoated carbide

Tool holders

QE\*D\*R/L

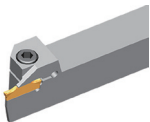

A425

System code > A398

Grade selection > A394

Technical info > A501



Cutting data > A456











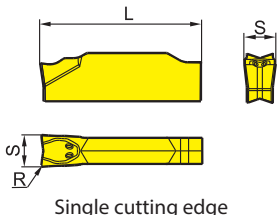







**A**

Turning

## Parting inserts

-  Ideal machining conditions
-  Normal machining conditions
-  Unfavourable machining conditions

Parting & grooving insert (single sided)					HC <sup>1</sup> (CVD)		HC <sup>1</sup> (PVD)			HW	
 <p>Single cutting edge</p>	<b>P</b>										
	<b>M</b>										
	<b>K</b>										
	<b>N</b>										
	<b>S</b>										
	<b>H</b>										

**B**

Milling



ISO	R±0.1	S±0.10	f	YBC252	YBC251	YBG105	YBG102	YB9320	YBG205	YBG202	YBG302	YD101	YD201
<b>ZPES02502-MG</b>	0.2	2.5	0,03-0,1					○	○	●			
<b>ZPFS0302-MG</b>	0.2	3	0,04-0,13	●				●		●			
<b>ZPGS0402-MG</b>	0.2	4	0,07-0,18	○						○	●	○	
<b>ZPGS0402-MG-25</b>	0.2	4	0,07-0,18					●					
<b>ZPHS0503-MG</b>	0.3	5	0,1-0,24						○	●			
<b>ZPHS0503-MG-25</b>	0.3	5	0,1-0,24					●					
<b>ZPKS0604-MG</b>	0.4	6	0,12-0,29							○	●		
<b>ZPKS0604-MG-25</b>	0.4	6	0,12-0,29					●					

● Ex stock   ○ On demand  
Single sided inserts only for parting blades

HC<sup>1</sup> Coated carbide  
HW Uncoated carbide

**C**

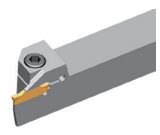
Drilling

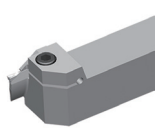
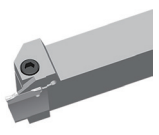
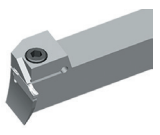
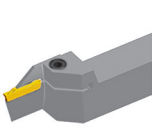
Tool holders					
QE*S*R/L	QZ**+QE**	QF*S*LL-H	QF*S*RR-H	QF*S*R/L-L	QF*S*R/L-H
					
A427	A432	A438	A438	A441	A442

**D**

Technical Information

**E**



Index

System code > A398











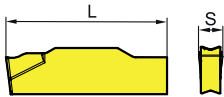







Grade selection > A394

Technical info > A501

Cutting data > A456

-  Ideal machining conditions
-  Normal machining conditions
-  Unfavourable machining conditions

Parting inserts

Parting & grooving insert (single sided)							HC <sup>1</sup> (CVD)		HC <sup>1</sup> (PVD)			HW					
  Single cutting edge	<b>P</b>																
	<b>M</b>																
	<b>K</b>																
	<b>N</b>																
	<b>S</b>																
<b>H</b>																	
ISO	R±0.1	L	S±0.10	θ	f	YBC252	YBC251			YBG105	YBG102	YB9320	YBG205	YBG202	YBG302	YD101	YD201
	<b>ZPES02502-MG-6L</b>	0.2	19.9	2.5	6°	0,03-0,08							●				
	<b>ZPES02502-MG-6R</b>	0.2	19.9	2.5	6°	0,03-0,08							●				
	<b>ZPFS0302-MG-6L</b>	0.2	19.9	3	6°	0,04-0,1							●				
	<b>ZPFS0302-MG-6R</b>	0.2	19.9	3	6°	0,04-0,1							●				

● Ex stock   ○ On demand

Single sided inserts only for parting blades

HC<sup>1</sup> Coated carbide  
HW Uncoated carbide

Tool holders

QZ\*\*+QE\*\*



A432

System code > A398

Grade selection > A394



Technical info > A501











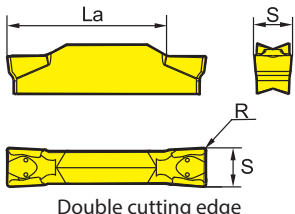







Cutting data > A456

**A**

Turning

## Parting inserts

-  Ideal machining conditions
-  Normal machining conditions
-  Unfavourable machining conditions



Parting & grooving insert (double sided)					HC <sup>1</sup> (CVD)		HC <sup>1</sup> (PVD)			HW				
	<b>P</b>	 					   							
	<b>M</b>						   							
	<b>K</b>													
	<b>N</b>									 				
	<b>S</b>							   						
	<b>H</b>													
ISO	R±0.1	La max	S±0.10	f	YBC252	YBC251	YBG105	YBG102	YB9320	YBG205	YBG202	YBG302	YD101	YD201
	ZTED02503-MG		17	2.5	0,03-0,11						○ ●			
	ZTFD0303-MG		17	3	0,04-0,14			○		● ● ●				
	ZTGD0402-MG		22	4	0,07-0,2									
	ZTGD0404-MG		22	4	0,07-0,2	●					● ○ ●			●
	ZTHD0504-MG		22	5	0,10-0,25						● ○ ●			
	ZTKD0604-MG		22	6	0,13-0,30				○ ●					
	ZTKD0608-MG		22	6	0,13-0,30			○ ●		○ ●				

● Ex stock ○ On demand

HC<sup>1</sup> Coated carbide  
HW Uncoated carbide

**C**

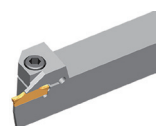
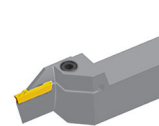
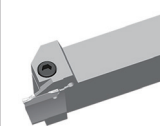
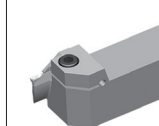
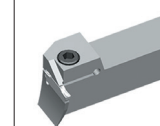
Drilling

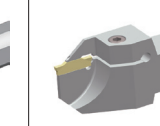
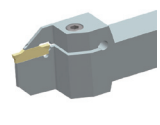
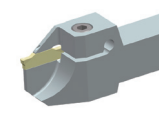
Tool holders						
QE*D*R/L	QF*D*R/L-H	QF*D*RR-H	QF*D*LL-H	QF*D*R/L-L	C***-Q*DR/L	QE*D*R/L-DGC
						
A425	A434	A436	A436	A439	A444	A446
QE*D*R/L-DGSC	QE*D*R/L-SC					
						
A448	A449					

**D**

Technical Information

**E**



Index

System code > A398











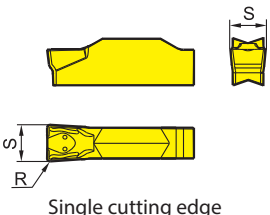







Grade selection > A394

Technical info > A501

Cutting data > A456





-  Ideal machining conditions
-  Normal machining conditions
-  Unfavourable machining conditions

Parting inserts

Parting & grooving insert (single sided)					HC <sup>1</sup> (CVD)		HC <sup>1</sup> (PVD)			HW		
 <p>Single cutting edge</p>	<b>P</b>											
	<b>M</b>											
	<b>K</b>											
	<b>N</b>											
	<b>S</b>											
	<b>H</b>											
ISO	R±0.1	S±0.10	f	YBC252 YBC251			YBG105 YBG102 YB9320 YBG205 YBG202 YBG302				YD101 YD201	
	<b>ZTHS0504-MG</b>	0.4	5	0,10-0,25					○	○	●	
	<b>ZTKS0608-MG</b>	0.8	6	0,13-0,30					○	●		

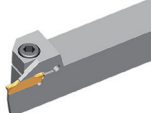
● Ex stock ○ On demand

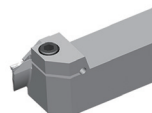
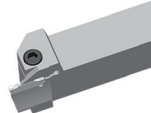
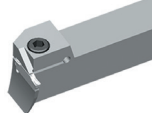
HC<sup>1</sup> Coated carbide  
HW Uncoated carbide

Tool holders					
<b>QE*S*/L</b>	<b>QZ**+QE**</b>	<b>QF*S*LL-H</b>	<b>QF*S*RR-H</b>	<b>QF*S*/L-L</b>	<b>QF*S*/L-H</b>
					
A427	A431	A438	A438	A441	A442

System code > A398

Grade selection > A394

Technical info > A501

Cutting data > A456





# Parting & grooving Inserts

**A**

Turning

- Ideal machining conditions
- ⊗ Normal machining conditions
- ⊗ Unfavourable machining conditions

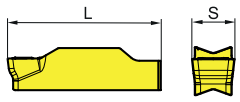
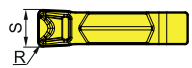
## Parting inserts

Parting & grooving insert (single sided)						HC <sup>1</sup> (CVD)		HC <sup>1</sup> (PVD)			HW			
						<b>P</b>	<span style="color: blue;">⊗</span> <span style="color: blue;">⊗</span>			<span style="color: blue;">⊗</span> <span style="color: blue;">⊗</span> <span style="color: blue;">⊗</span> <span style="color: grey;">⊗</span>				
						<b>M</b>				<span style="color: blue;">⊗</span> <span style="color: blue;">⊗</span> <span style="color: blue;">⊗</span> <span style="color: grey;">⊗</span>				
 <p>Single cutting edge</p>						<b>K</b>								
						<b>N</b>							<span style="color: green;">●</span> <span style="color: green;">⊗</span>	
						<b>S</b>			<span style="color: orange;">●</span> <span style="color: orange;">●</span> <span style="color: orange;">⊗</span> <span style="color: orange;">⊗</span>					
						<b>H</b>								
ISO		R±0.1	L	S±0.10	f	YBC252 YBC251			YBG105 YBG102 YB9320 YBG205 YBG202 YBG302			YD101 YD201		
	<b>ZTES02503-MM</b>	0.3	19.9	2.5	0,03-0,1				●					
	<b>ZTFS0303-MM</b>	0.3	19.9	3	0,04-0,13				●					
	<b>ZTGS0404-MM-25</b>	0.4	24.6	4	0,06-0,18				●					
	<b>ZTHS0504-MM-25</b>	0.4	24.6	5	0,08-0,23				●					
	<b>ZTKS0608-MM-25</b>	0.8	24.6	6	0,12-0,27				●					

● Ex stock    ○ On demand

 HC<sup>1</sup> Coated carbide  
 HW Uncoated carbide

**B**

Milling

**C**



Drilling

**D**

Technical Information

**E**

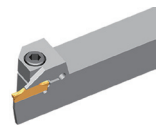
Index

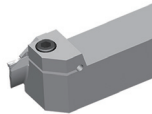
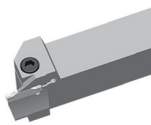
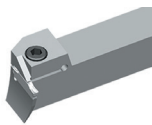
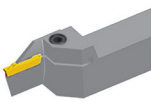
Tool holders					
<b>QE*S*R/L</b>	<b>QZ**+QE**</b>	<b>QF*S*LL-H</b>	<b>QF*S*RR-H</b>	<b>QF*S*R/L-L</b>	<b>QF*S*R/L-H</b>
					
A427	A432	A438	A438	A441	A442

System code &gt; A398

Grade selection &gt; A394

Technical info &gt; A501

Cutting data &gt; A456



Parting inserts

- Ideal machining conditions
- Normal machining conditions
- Unfavourable machining conditions

Parting & grooving insert (double sided)						HC <sup>1</sup> (CVD)		HC <sup>1</sup> (PVD)				HW				
						<b>P</b>										
						<b>M</b>										
						<b>K</b>										
						<b>N</b>										
						<b>S</b>										
						<b>H</b>										
ISO	La max	S±0.025	R±0.05	f	YBC252	YBC251		YBG105	YBG102	YB9320	YBG205	YBG202	YBG302	YD101	YD201	
ZTCD01002-EG	2.6	1	0.2	0,02-0,04									○			
ZTCD011502-EG	2.6	1.15	0.2	0,02-0,04									○			
ZTCD01202-EG	2.6	1.2	0.2	0,02-0,04									○			
ZTCD013802-EG	2.6	1.38	0.2	0,02-0,04									○			
ZTCD01402-EG	2.6	1.4	0.2	0,02-0,04									○			
ZTCD01500-EG	2.6	1.5	0	0,02-0,04									○			
ZTCD01502-EG	2.6	1.5	0.2	0,02-0,04									○			
ZTCD01503-EG	2.6	1.5	0.3	0,02-0,04									○			
ZTCD015503-EG	2.6	1.55	0.3	0,02-0,04									○			
ZTCD01602-EG	2.6	1.6	0.2	0,02-0,04									○			
ZTCD01702-EG	3.4	1.7	0.2	0,02-0,08									○			
ZTCD017503-EG	3.4	1.75	0.3	0,02-0,08									○			
ZTCD017602-EG	3.4	1.76	0.2	0,02-0,08									○			
ZTCD01802-EG	3.4	1.8	0.2	0,02-0,08									○			
ZTCD018502-EG	3.4	1.85	0.2	0,02-0,08									○			
ZTCD02000-EG	3.4	2	0	0,02-0,08									○			
ZTCD02002-EG	3.4	2	0.2	0,02-0,08									●			
ZTCD020503-EG	3.4	2.05	0.3	0,02-0,08									○			
ZTCD021502-EG	3.4	2.15	0.2	0,02-0,08									○			
ZTCD02302-EG	3.4	2.3	0.2	0,03-0,11									○			
ZTCD02303-EG	3.4	2.3	0.3	0,03-0,11									○			
ZTCD02402-EG	3.4	2.4	0.2	0,03-0,11									○			

● Ex stock ○ On demand

HC<sup>1</sup> Coated carbide  
HW Uncoated carbide

Tool holders

QECD

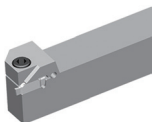

A428

System code > A398

Grade selection > A394

Technical info > A501

Cutting data > A456















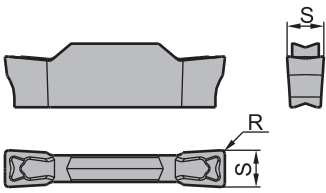







A

Turning

## Parting inserts

-  Ideal machining conditions
-  Normal machining conditions
-  Unfavourable machining conditions

Parting & grooving insert (double sided)					HC <sup>1</sup> (CVD)		HC <sup>1</sup> (PVD)			HW		
	<b>P</b>											
	<b>M</b>											
	<b>K</b>											
	<b>N</b>											
	<b>S</b>											
	<b>H</b>											

B

Milling

ISO	La max	S±0.025	R±0.05	f	YBC252 YBC251		YBG105 YBG102 YB9320 YBG205 YBG202 YBG302					YD101 YD201			
ZTED02502-EG	17	2.5	0.2	0,03-0,11											
ZTED026502-EG	17	2.65	0.2	0,03-0,11											
ZTED02702-EG	17	2.7	0.2	0,03-0,11											
ZTED02703-EG	17	2.7	0.3	0,03-0,11											
ZTED02802-EG	17	2.8	0.2	0,04-0,13											
ZTED02803-EG	17	2.8	0.3	0,04-0,13											
ZTED02804-EG	17	2.8	0.4	0,04-0,13											
ZTED02903-EG	17	2.9	0.3	0,04-0,13											
ZTFD03001-EG	17	3	0.1	0,04-0,13											
ZTFD03002-EG	17	3	0.2	0,04-0,13											
ZTFD03003-EG	17	3	0.3	0,04-0,13											
ZTFD03203-EG	17	3.2	0.3	0,04-0,13											
ZTFD0325024-EG	17	3.25	2.4	0,04-0,13											
ZTFD03302-EG	17	3.3	0.2	0,04-0,13											
ZTFD03303-EG	17	3.3	0.3	0,04-0,13											
ZTFD03403-EG	17	3.4	0.3	0,04-0,13											
ZTFD035-EG	17	3.5	0	0,04-0,13											
ZTGD039602-EG	22	3.96	0.2	0,07-0,18											
ZTGD04002-EG	22	4	0.2	0,07-0,18											
ZTGD04003-EG	22	4	0.3	0,07-0,18											
ZTGD04004-EG	22	4	0.4	0,07-0,18											
ZTGD04008-EG	22	4	0.8	0,07-0,18											
ZTGD04503-EG	22	4.5	0.3	0,07-0,18											
ZTGD04505-EG	22	4.5	0.5	0,07-0,18											
ZTGD04805-EG	22	4.8	0.5	0,1-0,24											
ZTHD05003-EG	22	5	0.3	0,1-0,24											
ZTHD05004-EG	22	5	0.4	0,1-0,24											
ZTHD05008-EG	22	5	0.8	0,1-0,24											
ZTHD05012-EG	22	5	0.12	0,1-0,24											
ZTHD05202-EG	22	5.2	0.2	0,1-0,24											
ZTHD052503-EG	22	5.25	0.3	0,1-0,24											
ZTHD05508-EG	22	5.5	0.8	0,1-0,24											

C

Drilling

D

Technical Information

E

Index

● Ex stock    ○ On demand



HC<sup>1</sup> Coated carbide  
HW Uncoated carbide

System code > A398











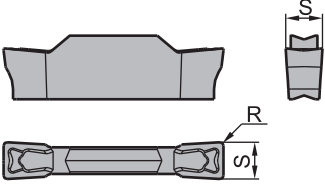





Grade selection > A394

Technical info > A501

Cutting data > A456

-  Ideal machining conditions
-  Normal machining conditions
-  Unfavourable machining conditions



**Parting inserts**

Parting & grooving insert (double sided)						HC <sup>1</sup> (CVD)		HC <sup>1</sup> (PVD)			HW	
	<b>P</b>											
	<b>M</b>											
	<b>K</b>											
	<b>N</b>											
	<b>S</b>											
	<b>H</b>											
ISO	La max	S±0.025	R±0.05	f	YBC252 YBC251			YBG105 YBG102 YB9320 YBG205 YBG202 YBG302			YD101 YD201	
	<b>ZTKD06004-EG</b>	22	6	0,4	0,12-0,29							
	<b>ZTKD06504-EG</b>	22	6,5	0,4	0,12-0,29							

● Ex stock    ○ On demand

HC<sup>1</sup> Coated carbide  
HW Uncoated carbide

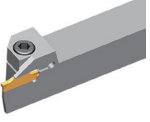
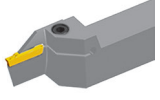
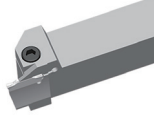
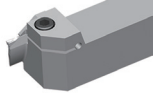
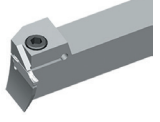
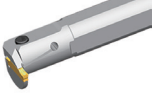
**Tool holders**

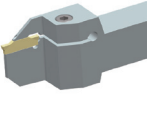
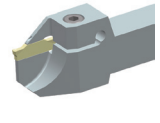
QE*D*R/L	QF*D*R/L-H	QF*D*RR-H	QF*D*LL-H	QF*D*R/L-L	C***-Q*DR/L	QE*D*R/L-DGC
						
A425	A434	A436	A436	A439	A444	A446
QE*D*R/L-DGSC	QE*D*R/L-SC					
						
A448	A449					

**A**

Turning

**B**

Milling

**C**

Drilling

**D**

Technical Information

**E**

Index

System code > A398

Grade selection > A394

Technical info > A501



Cutting data > A456











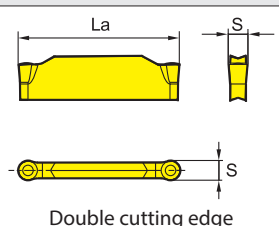





**A**

Turning

## Parting inserts

-  Ideal machining conditions
-  Normal machining conditions
-  Unfavourable machining conditions

Parting & grooving insert (double sided)		HC <sup>1</sup> (CVD)		HC <sup>1</sup> (PVD)		HW			
 <p>Double cutting edge</p>	<b>P</b>								
	<b>M</b>								
	<b>K</b>								
	<b>N</b>								
	<b>S</b>								
<b>H</b>									

**B**

Milling

ISO	La max	S±0.10	f	YBC252		YBC251		YBG105		YBG102		YBG320		YBG205		YBG202		YBG302		YD101		YD201	
				●	○	●	○	●	○	●	○	●	○	●	○	●	○	●	○	●	○	●	○
	<b>ZRED025-MG</b>	17.5	2.5	0,03-0,11																			
	<b>ZRFD03-MG</b>	17	3	0,04-0,14																			
	<b>ZRGD04-MG</b>	21	4	0,07-0,2		○																	
	<b>ZRHD05-MG</b>	20	5	0,1-0,24																			○
	<b>ZRKD06-MG</b>	19	6	0,12-0,29																			

● Ex stock ○ On demand

HC<sup>1</sup> Coated carbide  
HW Uncoated carbide

**C**

Drilling

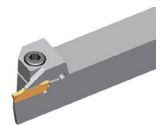
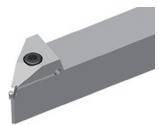
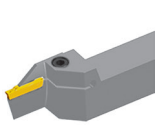
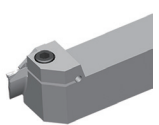
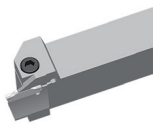
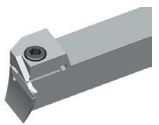
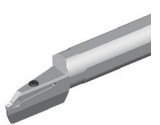
Tool holders						
QE*D*R/L	QX*D*	QF*D*R/L-H	QF*D*LL-H	QF*D*RR-H	QF*D*R/L-L	C*X-Q*DR/L
						
A425	A429	A434	A436	A436	A439	A443

C\*\*\*-Q\*DR/L

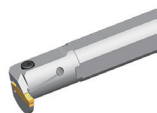

A444

**D**

Technical Information

**E**



Index

System code > A398











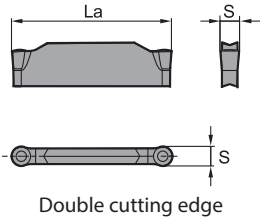













Grade selection > A394

Technical info > A501

Cutting data > A456

-  Ideal machining conditions
-  Normal machining conditions
-  Unfavourable machining conditions

Parting inserts

Parting & grooving insert (double sided)					HC <sup>1</sup> (CVD)		HC <sup>1</sup> (PVD)			HW				
 <p>Double cutting edge</p>	<b>P</b>													
	<b>M</b>													
	<b>K</b>													
	<b>N</b>													
	<b>S</b>													
	<b>H</b>													
ISO	La max	S±0.025	f	YBC252	YBC251		YBG105	YBG102	YB9320	YBG205	YBG202	YBG302	YD101	YD201
	<b>ZRFD03-EG</b>	17	3	0,04-0,14										
	<b>ZRGD04-EG</b>	21	4	0,07-0,2										
	<b>ZRHD05-EG</b>	20	5	0,1-0,24										
	<b>ZRKD06-EG</b>	19	6	0,12-0,29										

● Ex stock ○ On demand

HC<sup>1</sup> Coated carbide  
HW Uncoated carbide

Tool holders

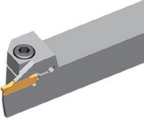
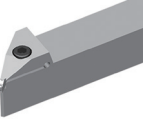
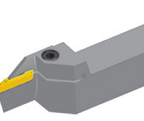
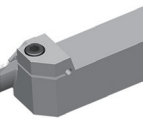
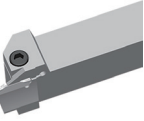
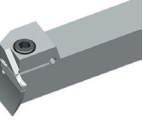
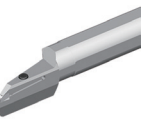
QE*D*R/L	QX*D*	QF*D*R/L-H	QF*D*LL-H	QF*D*RR-H	QF*D*R/L-L	C*X-Q*DR/L
						
A425	A429	A434	A436	A436	A439	A443

C\*\*\*-Q\*DR/L

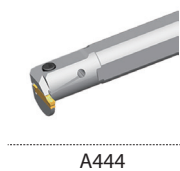

System code > A398

Grade selection > A394

Technical info > A501



Cutting data > A456











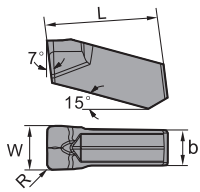







**A**

Turning









## Parting inserts

-  Ideal machining conditions
-  Normal machining conditions
-  Unfavourable machining conditions

Parting & grooving insert (single sided)							HC <sup>1</sup> (CVD)		HC <sup>1</sup> (PVD)			HW		
	<b>P</b>													
	<b>M</b>													
	<b>K</b>													
	<b>N</b>													
	<b>S</b>													
	<b>H</b>													

**B**

Milling

ISO	R±0.1	W±0.05	b	L	f	YBC252		YBC251		YBG105		YBG102		YB9320		YBG205		YBG202		YBG302		YD101		YD201	
 <b>ZIMF304N-NM</b>	0.4	3	2.4	15.3	0,04-0,11																				
<b>ZIMF406N-NM</b>	0.6	4	3.2	15.3	0,07-0,16																				
<b>ZIMF506N-NM</b>	0.6	5	4	15.3	0,1-0,2																				
<b>ZIMF608N-NM</b>	0.8	6	4	15.3	0,12-0,23																				

● Ex stock    ○ On demand

HC<sup>1</sup> Coated carbide  
HW Uncoated carbide

**C**

Drilling

Tool holders  
**QE\*S\*R/L-N**

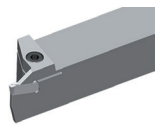

A430

**D**

Technical Information

**E**



Index

System code > A398











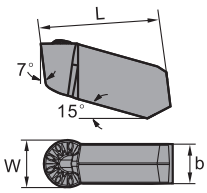







Grade selection > A394

Technical info > A501

Cutting data > A456

-  Ideal machining conditions
-  Normal machining conditions
-  Unfavourable machining conditions

**Parting inserts**

Parting & grooving insert (single sided)					HC <sup>1</sup> (CVD)		HC <sup>1</sup> (PVD)				HW				
	<b>P</b>														
	<b>M</b>														
	<b>K</b>														
	<b>N</b>														
	<b>S</b>														
	<b>H</b>														
ISO	W±0.05	b	L	f	YBC252	YBC251		YBG105	YBG102	YB9320	YBG205	YBG202	YBG302	YD101	YD201
	<b>ZIGQ3N-NM</b>	3	2.4	15.3	0,04-0,11			●	○						
	<b>ZIGQ4N-NM</b>	4	3.2	15.3	0,07-0,16			●	○						
	<b>ZIGQ5N-NM</b>	5	4	15.3	0,1-0,2			●	○						
	<b>ZIGQ6N-NM</b>	6	5	15.3	0,13-0,24			●							

● Ex stock    ○ On demand

HC<sup>1</sup> Coated carbide  
HW Uncoated carbide

Tool holders

QE\*S\*R/L-N

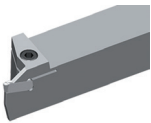

A430

System code > A398

Grade selection > A394

Technical info > A501

Cutting data > A456

**A**

Turning

**B**

Milling

**C**

Drilling

**D**

Technical Information



**E**











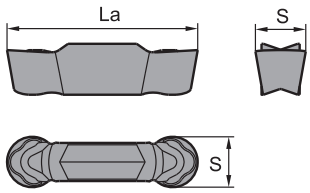







Index

**A**

Turning

## Parting inserts

-  Ideal machining conditions
-  Normal machining conditions
-  Unfavourable machining conditions

Parting & grooving insert (double sided)					HC <sup>1</sup> (CVD)		HC <sup>1</sup> (PVD)			HW					
	<b>P</b>														
	<b>M</b>														
	<b>K</b>														
	<b>N</b>														
	<b>S</b>														
	<b>H</b>														
	ISO	La max	S±0.025	f	YBC252	YBC251		YBG105	YBG102	YB9320	YBG205	YBG202	YBG302	YD101	YD201
	<b>ZRKD06-LH</b>	19	6	0,12-0,23											
	<b>ZRLD08-LH</b>	22	8	0,14-0,26											

● Ex stock    ○ On demand

HC<sup>1</sup> Coated carbide  
HW Uncoated carbide

**B**

Milling

**C**

Drilling

**D**

Technical Information

**E**

Index

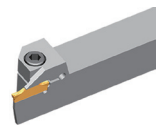
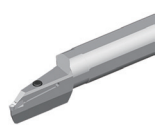
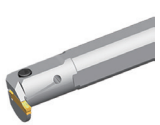

Tool holders		
QE*D*R/L	C*X-Q*DR/L	C***-Q*DR/L
		
A425	A443	A444

System code > A398











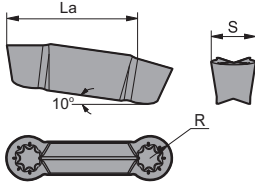





Grade selection > A394

Technical info > A501

Cutting data > A456

-  Ideal machining conditions
-  Normal machining conditions
-  Unfavourable machining conditions

**Parting inserts**

Parting & grooving insert (double sided)					HC <sup>1</sup> (CVD)		HC <sup>1</sup> (PVD)			HW	
	<b>P</b>										
	<b>M</b>										
	<b>K</b>										
	<b>N</b>										
	<b>S</b>										
	<b>H</b>										
ISO	La max	S±0.025	f	YBC252 YBC251			YBG105 YBG102 YB9320 YBG205 YBG202 YBG302				YD101 YD201
	<b>ZILD08-LC</b>	22	8	0,14-0,26							○ ○

● Ex stock    ○ On demand

HC<sup>1</sup> Coated carbide  
HW Uncoated carbide

**A**

Turning

**B**

Milling

**C**

Drilling

**D**

Technical  
Information

**E**

Index

System code > A398

Grade selection > A394

Technical info > A501

Cutting data > A456









## Triangular, tangential grooving inserts (straight edge)

# QC 22 R 300 – R 03

1      2      3      4      5      6

Series	Cutting edge length [mm]		Cutting direction	
	Code	I.C	Code	Description
	11	6,35	R	 Right
	16	9,525	L	 Left
22	12,70			

1      2      3



Groove width [mm]		Edge shape		Radius/Chamfer [mm]	
Code	Description	Code	Description	Code	Description
050	0,50	R	 Radius	005	0,05
100	1,00	C	 Chamfer	02	0,2
...	...			03	0,3
480	4,80			04	0,4

4      5      6

## Triangular, tangential grooving inserts (round edge)

# QC 22 R 300 – R

1      2      3      4      5

Series	Cutting edge length [mm]		Cutting direction		Groove width [mm]		Round
	Code	I.C	Code	Description	Code	Description	
	11	6,35	R	 Right	050	0,50	
	16	9,525	L	 Left	100	1,00	
22	12,70			...	...		
				480	4,80		

1      2      3      4      5

A

Turning

B

Milling

C

Drilling



D

Technical Information

E

Index

## Parting inserts

-  Ideal machining conditions
-  Normal machining conditions
-  Unfavourable machining conditions

QC\*\* turning/milling insert

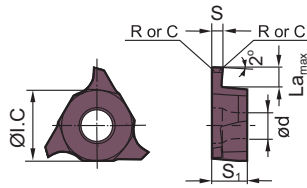

Right hand style

QC** turning/milling insert								HC <sup>1</sup> (CVD)		HC <sup>1</sup> (PVD)			HW				
								P	M	K	N	S	H				
ISO	La max	S±0.025	R/C	ØI.C	S1	ød	f	YBC252	YBC251	YBG105	YBG102	YB9320	YBG205	YBG202	YBG302	YD101	YD201
QC11R120-R02	1.5	1.2	0.2	6.35	3.18	2.8	0,02-0,03						●				
QC11L120-R02	1.5	1.2	0.2	6.35	3.18	2.8	0,02-0,03						●				
QC11R125-R02	1.5	1.25	0.2	6.35	3.18	2.8	0,02-0,03						●				
QC11L125-R02	1.5	1.25	0.2	6.35	3.18	2.8	0,02-0,03						●				
QC11R145-R02	1.5	1.45	0.2	6.35	3.18	2.8	0,02-0,05						●				
QC11L145-R02	1.5	1.45	0.2	6.35	3.18	2.8	0,02-0,05						●				
QC11R150-R02	1.5	1.5	0.2	6.35	3.18	2.8	0,02-0,05						●				
QC11L150-R02	1.5	1.5	0.2	6.35	3.18	2.8	0,02-0,05						●				
QC11R200-R02	2	2	0.2	6.35	3.18	2.8	0,02-0,06						●				
QC11L200-R02	2	2	0.2	6.35	3.18	2.8	0,02-0,06						●				
QC11R225-R02	2	2.25	0.2	6.35	3.18	2.8	0,02-0,06						○				
QC11L225-R02	2	2.25	0.2	6.35	3.18	2.8	0,02-0,06						○				
QC16R075-R01	2	0.75	0.1	9.525	3.18	4.4	0,02-0,03						○				
QC16L075-R01	2	0.75	0.1	9.525	3.18	4.4	0,02-0,03						○				
QC16R080-R01	2	0.8	0.1	9.525	3.18	4.4	0,02-0,03						○				
QC16R095-R01	2	0.95	0.1	9.525	3.18	4.4	0,02-0,03						○				
QC16L095-R01	2	0.95	0.1	9.525	3.18	4.4	0,02-0,03						○				
QC16L100-R01	2	1	0.1	9.525	3.18	4.4	0,02-0,03						○				
QC16R110-R01	2	1.1	0.1	9.525	3.18	4.4	0,02-0,03						○				
QC16L110-R01	2	1.1	0.1	9.525	3.18	4.4	0,02-0,03						● ○				
QC16R115-R04	2	1.15	0.4	9.525	3.18	4.4	0,02-0,03						○				
QC16R120-R01	2	1.2	0.1	9.525	3.18	4.4	0,02-0,03						○				
QC16L120-R01	2	1.2	0.1	9.525	3.18	4.4	0,02-0,03						○				
QC16R125-R02	2	1.25	0.2	9.525	3.18	4.4	0,02-0,03						○				
QC16L125-R02	2	1.25	0.2	9.525	3.18	4.4	0,02-0,03						●				
QC16R130-R02	2	1.3	0.2	9.525	3.18	4.4	0,02-0,06						○				
QC16L130-R02	2	1.3	0.2	9.525	3.18	4.4	0,02-0,06						○				
QC16R140-R02	2	1.4	0.2	9.525	3.18	4.4	0,02-0,06						○				
QC16R145-R02	2	1.45	0.2	9.525	3.18	4.4	0,02-0,06						●				
QC16L145-R02	2	1.45	0.2	9.525	3.18	4.4	0,02-0,06						●				
QC16R150-R02	2	1.5	0.2	9.525	3.18	4.4	0,02-0,06						●				
QC16L150-R02	2	1.5	0.2	9.525	3.18	4.4	0,02-0,06						○				
QC16R160-R02	2	1.6	0.2	9.525	3.18	4.4	0,02-0,06						●				
QC16L160-R02	2	1.6	0.2	9.525	3.18	4.4	0,02-0,06						●				

● Ex stock ○ On demand

HC<sup>1</sup> Coated carbide  
HW Uncoated carbide





**A**  
Turning  
  
**B**  
Milling  
  
**C**  
Drilling  
  
**D**  
Technical Information  
  
**E**  
Index

A

Turning

### Parting inserts

-  Ideal machining conditions
-  Normal machining conditions
-  Unfavourable machining conditions

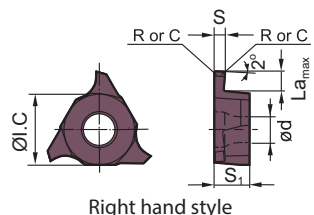

QC** turning/milling insert								HC <sup>1</sup> (CVD)		HC <sup>1</sup> (PVD)			HW				
								P									
								M									
								K									
								N									
								S									
								H									
ISO	La max	S±0.025	R/C	Øl.C	S1	Ød	f	YBC252	YBC251	YBG105	YBG102	YB9320	YBG205	YBG202	YBG302	YD101	YD201
QC16R165-R02	2	1.65	0.2	9.525	3.18	4.4	0,02-0,06						○				
QC16L165-R02	2	1.65	0.2	9.525	3.18	4.4	0,02-0,06						○				
QC16R170-R02	2	1.7	0.2	9.525	3.18	4.4	0,02-0,06						○				
QC16L170-R02	2	1.7	0.2	9.525	3.18	4.4	0,02-0,06						○				
QC16R175-R02	2	1.75	0.2	9.525	3.18	4.4	0,02-0,07						●				
QC16L175-R02	2	1.75	0.2	9.525	3.18	4.4	0,02-0,06						○				
QC16R180-R02	2	1.8	0.2	9.525	3.18	4.4	0,02-0,07						○				
QC16R185-R02	2.5	1.85	0.2	9.525	3.18	4.4	0,02-0,07						●				
QC16L185-R02	2.5	1.85	0.2	9.525	3.18	4.4	0,02-0,07						○				
QC16R200-R02	2.5	2	0.2	9.525	3.18	4.4	0,02-0,07						●				
QC16L200-R02	2.5	2	0.2	9.525	3.18	4.4	0,02-0,07						●				
QC16L210-R02	2.5	2.1	0.2	9.525	3.18	4.4	0,02-0,07						○				
QC16L210-R05	2.5	2.1	0.5	9.525	3.18	4.4	0,02-0,07						○				
QC16R220-R02	2.5	2.2	0.2	9.525	3.18	4.4	0,02-0,07						○				
QC16L220-R02	2.5	2.2	0.2	9.525	3.18	4.4	0,02-0,07						○				
QC16R250-R02	2.5	2.5	0.2	9.525	3.18	4.4	0,02-0,08						● ○				
QC16L250-R02	2.5	2.5	0.2	9.525	3.18	4.4	0,02-0,08						●				
QC16R300-R02	3	3	0.2	9.525	3.18	4.4	0,03-0,11						●				
QC16L300-R02	3	3	0.2	9.525	3.18	4.4	0,03-0,11						●				
QC22L100-R02	2	1	0.2	12.7	4.76	5.5	0,02-0,03						○				
QC22R125-R02	2	1.25	0.2	12.7	4.76	5.5	0,02-0,03						●				
QC22L125-R02	2	1.25	0.2	12.7	4.76	5.5	0,02-0,03						○				
QC22R145-R02	2	1.45	0.2	12.7	4.76	5.5	0,02-0,06						○				
QC22L145-R02	2	1.45	0.2	12.7	4.76	5.5	0,02-0,06						○				
QC22R150-R02	3.5	1.5	0.2	12.7	4.76	5.5	0,02-0,06						○				
QC22L150-R02	3.5	1.5	0.2	12.7	4.76	5.5	0,02-0,06						○				
QC22R175-R02	3.5	1.75	0.2	12.7	4.76	5.5	0,02-0,06						●				
QC22L175-R02	3.5	1.75	0.2	12.7	4.76	5.5	0,02-0,06						○				
QC22R185-R02	3.5	1.85	0.2	12.7	4.76	5.5	0,02-0,07						●				
QC22L185-R02	3.5	1.85	0.2	12.7	4.76	5.5	0,02-0,07						○				
QC22R195-R02	3.5	1.95	0.2	12.7	4.76	5.5	0,02-0,07						○				
QC22R200-R02	3.5	2	0.2	12.7	4.76	5.5	0,02-0,07						○				
QC22L200-R02	3.5	2	0.2	12.7	4.76	5.5	0,02-0,07						○				
QC22R225-R02	3.5	2.25	0.2	12.7	4.76	5.5	0,02-0,07						○				

● Ex stock ○ On demand

HC<sup>1</sup> Coated carbide  
HW Uncoated carbide

B

Milling

C

Drilling

D

Technical Information

E

Index



System code > A416

Grade selection > A394









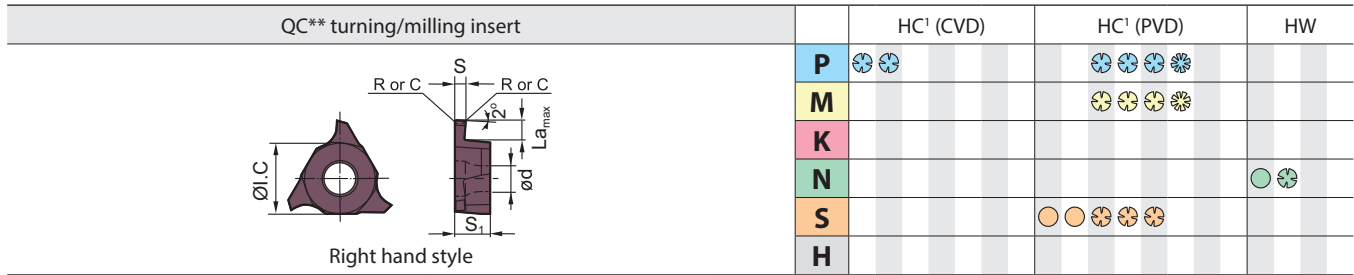



Technical info > A501

Cutting data > A456

## Parting inserts

-  Ideal machining conditions
-  Normal machining conditions
-  Unfavourable machining conditions



QC** turning/milling insert									HC <sup>1</sup> (CVD)		HC <sup>1</sup> (PVD)			HW					
									P										
									M										
									K										
									N										
									S										
									H										
ISO	La max	S±0.025	R/C	ØI.C	S1	ød	f		YBC252	YBC251		YBG105	YBG102	YB9320	YBG205	YBG202	YBG302	YD101	YD201
QC22R230-R02	3.5	2.3	0.2	12.7	4.76	5.5	0,02-0,07								●				
QC22L230-R02	3.5	2.3	0.2	12.7	4.76	5.5	0,02-0,07								○				
QC22R250-R03	4	2.5	0.3	12.7	4.76	5.5	0,02-0,08								●				
QC22L250-R03	4	2.5	0.3	12.7	4.76	5.5	0,02-0,08								○				
QC22R265-R03	4	2.65	0.3	12.7	4.76	5.5	0,02-0,08								●				
QC22L265-R03	4	2.65	0.3	12.7	4.76	5.5	0,02-0,08								●				
QC22R280-R03	4	2.8	0.3	12.7	4.76	5.5	0,02-0,08								●				
QC22L280-R03	4	2.8	0.3	12.7	4.76	5.5	0,02-0,08								○				
QC22R300-R03	4	3	0.3	12.7	4.76	5.5	0,03-0,11								○				
QC22L300-R03	4	3	0.3	12.7	4.76	5.5	0,03-0,11								○				
QC22R320-R03	4	3.2	0.3	12.7	4.76	5.5	0,03-0,11								○				
QC22L320-R03	4	3.2	0.3	12.7	4.76	5.5	0,03-0,11								○				
QC22R330-R03	4	3.3	0.3	12.7	4.76	5.5	0,03-0,11								○				
QC22L330-R03	4	3.3	0.3	12.7	4.76	5.5	0,03-0,11								○				
QC22R350-R03	5	3.5	0.3	12.7	4.76	5.5	0,05-0,13								○				
QC22L350-R03	5	3.5	0.3	12.7	4.76	5.5	0,05-0,13								○				
QC22R400-R04	5	4	0.4	12.7	4.76	5.5	0,05-0,14								○				
QC22L400-R04	5	4	0.4	12.7	4.76	5.5	0,05-0,14								●				
QC22R430-R04	5	4.3	0.4	12.7	4.76	5.5	0,05-0,14								○				
QC22L430-R04	5	4.3	0.4	12.7	4.76	5.5	0,05-0,14								○	○			
QC22R450-R04	5	4.5	0.4	12.7	4.76	5.5	0,06-0,18								○				
QC22L450-R04	5	4.5	0.4	12.7	4.76	5.5	0,06-0,18								○				○
QC22R480-R04	5	4.8	0.4	12.7	5.06	5.5	0,06-0,18								○				
QC22L480-R04	5	4.8	0.4	12.7	5.06	5.5	0,08-0,2								○				

● Ex stock ○ On demand

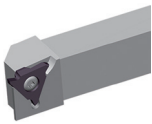
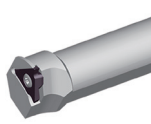

HC<sup>1</sup> Coated carbide  
HW Uncoated carbide

Tool holders	
GQCR/L	S***-QC**R/L
	
A453	A454

A







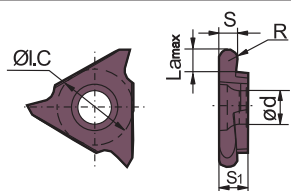









Turning

## Parting inserts

-  Ideal machining conditions
-  Normal machining conditions
-  Unfavourable machining conditions



Right hand style

QC** turning/milling insert		HC <sup>1</sup> (CVD)		HC <sup>1</sup> (PVD)			HW	
<b>P</b>	 			   				
<b>M</b>				   				
<b>K</b>								
<b>N</b>							 	
<b>S</b>				   				
<b>H</b>								

B

Milling

ISO	La max	S±0.025	R/C	Øl.C	S1	ød	f	YBC252		YBC251		YBG105		YBG102		YBG9320		YBG205		YBG202		YBG302		YD101		YD201		
QC16R100R	2	1	0.5	12.7	3.18	4.4	0,02-0,03																					
QC16R120R	2	1.2	0.6	12.7	3.18	4.4	0,02-0,03																					
QC16R150R	2	1.5	0.75	12.7	3.18	4.4	0,02-0,06																					
QC16R200R	2.5	2	1	12.7	3.18	4.4	0,02-0,07																					
QC16L200R	2.5	2	1	12.7	3.18	4.4	0,02-0,07																					
QC16R250R	2.5	2.5	1.25	12.7	3.18	4.4	0,02-0,08																					
QC16L280R	2.5	2.8	1.4	12.7	3.18	4.4	0,02-0,08																					
QC16R300R	2.5	3	1.5	12.7	3.18	4.4	0,03-0,11																					
QC16L300R	2.5	3	1.5	12.7	3.18	4.4	0,03-0,11																					
QC22R100R	2	1	0.5	12.7	4.76	5.5	0,02-0,03																					
QC22L100R	2	1	0.5	12.7	4.76	5.5	0,02-0,03																					
QC22R150R	3.5	1.5	0.75	12.7	4.76	5.5	0,02-0,06																					
QC22L150R	3.5	1.5	0.75	12.7	4.76	5.5	0,02-0,06																					
QC22R170R	3.5	1.7	0.85	12.7	4.76	5.5	0,02-0,06																					
QC22R200R	3.5	2	1	12.7	4.76	5.5	0,02-0,07																					
QC22L200R	3.5	2	1	12.7	4.76	5.5	0,02-0,07																					
QC22R250R	4	2.5	1.25	12.7	4.76	5.5	0,02-0,08																					
QC22L250R	4	2.5	1.25	12.7	4.76	5.5	0,02-0,08																					
QC22R300R	4	3	1.5	12.7	4.76	5.5	0,03-0,11																					
QC22L300R	4	3	1.5	12.7	4.76	5.5	0,03-0,11																					
QC22R320R	4	3.2	1.6	12.7	4.76	5.5	0,03-0,11																					
QC22R400R	5	4	2	12.7	4.76	5.5	0,05-0,14																					
QC22L400R	5	4	2	12.7	4.76	5.5	0,05-0,14																					

C

Drilling



D

Technical Information

● Ex stock    ○ On demand

HC<sup>1</sup> Coated carbide  
HW Uncoated carbide

### Tool holders

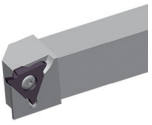
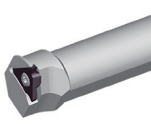
GQCR/L	S***-QC**R/L
	
A453	A454

E

Index

System code > A416

Grade selection > A394

Technical info > A501

Cutting data > A456

Notes

Handwriting practice area with horizontal dotted lines.

**A**  
Turning

**B**  
Milling

**C**  
Drilling

**D**  
Technical Information

**E**  
Index



## External tool holders

**Q F G D 2525 R 22 (S) C – (130) (H)**

**1 2 3 4 5 6 7 8 9 10 11**

<b>Holder for parting &amp; grooving</b>
--

**1**

Application	
Code	Description
E	External machining
F	Axial machining

**2**

Insert seat size [mm]	
Holder/cutting width	
Code	Description
A	1,5
B	2,0
E	2,5
F	3,0
G	4,0
H	5,0
K	6,0
L	8,0

**3**

No. of cutting edges	
Code	Description
S	Single
D	Double

**4**

<b>Cross section of holder [mm] x [mm]</b>
--

**5**

Type	
Code	Description
R	Right
L	Left
N	Right and left

**6**

<b>Max. cutting depth [mm]</b>
--------------------------------

**7**

Serie	
Code	Description
S	Swiss turning holder
DG	Cut-off holder for greater grooving depths with reinforcement
DGS	Cut-off holder for greater grooving depths without reinforcement

**8**

<b>With internal cooling</b>
------------------------------

**9**

<b>Min. diameter of work piece for first axial grooving [mm]</b>
--

**10**

Cutting head	
Code	Description
H	0°
L	90°

**11**

**Boring bars**

**C 32 S – Q G D R 11 – 44**

1 2 3 4 5 6 7 8 9

Clamping system	Diameter [mm]	Length [mm]		Holder for grooving
		Code	Description	
1	2	Q	180	4
		R	200	
		S	250	
		X	320	
3		4		

Insert seat size [mm]		No. of cutting edges	
Holder/Cutting width		Code	Description
Code	Description	S	Single
B	2.0	D	Double
E	2.5		
F	3.0		
G	4.0		
H	5.0		
K	6.0		
L	8.0		
5		6	

Type		Max. cutting depth [mm]	Min. internal diameter of work piece [mm]
Code	Description		
R	Right	8	9
L	Left		
N	Right and left		
7			

**A**  
Turning  
**B**  
Milling  
**C**  
Drilling  
**D**  
Technical Information  
**E**  
Index



## Blade

**Q E G D 32 N (-1)**

**1 2 3 4 5 6 7**



**1**

Application	
Code	Description
E	External machining

**2**

Insert seat size [mm]	
Holder/cutting width	
Code	Description
B	2,0
E	2,5
F	3,0
G	4,0
H	5,0
K	6,0
L	8,0

**3**

No. of cutting edges	
Code	Description
S	Single
D	Double

**4**

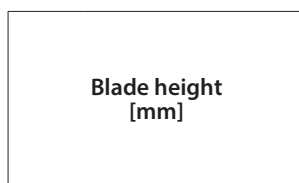

**5**

Type	
Code	Description
R	Right
L	Left
N	Right and left

**6**



**7**

## Clamping block

**QZ S 32 32**

**1 2 3 4**

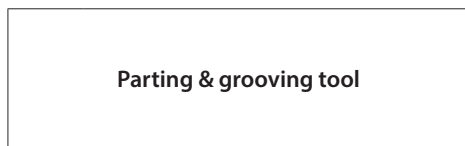

**1**

No. of cutting edges	
Code	Description
S	Single
D	Double

**2**

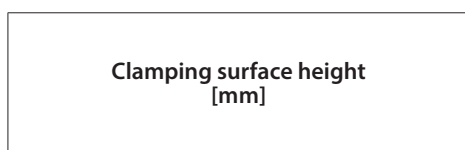

**3**

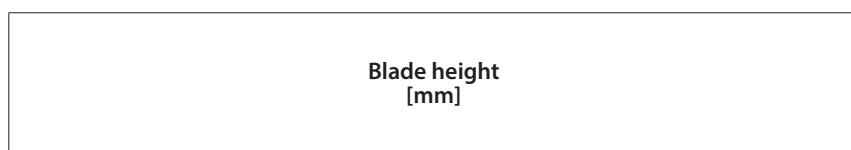

**4**

**Parting & grooving tool holder (external)**

QE\*\*R/L

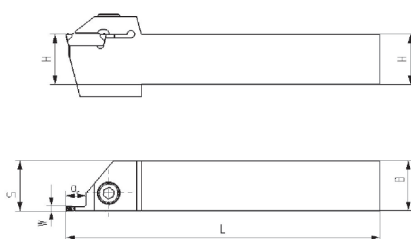
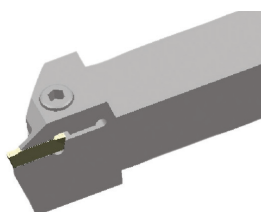

Article	*	Stock		Dimensions [mm]					Inserts
		R	L	HxB	L	S	W	ar <sub>max</sub>	
QEED1616R/L10	●	●	16x16	125	15	2.5	10	Z*ED**	
QEED1616R/L17	●	●	16x16	125	15	2.5	17	Z*ED**	
QEED2020R/L17	●	●	20x20	125	19	2.5	17	Z*ED**	
QEED2020R/L10	●	●	20x20	150	10	2.5	10	Z*ED**	
QEED2525R/L10	●	●	25x25	150	19	2.5	10	Z*ED**	
QEED2525R/L17	●	●	25x25	150	19	2.5	17	Z*ED**	
QEGD2020R/L13	●	●	20x20	140	18.5	4	13	Z*GD**	
QEGD2020R/L22	●	●	20x20	140	18.5	4	22	Z*GD**	
QEGD2525R/L13	●	●	25x25	150	23.5	4	13	Z*GD**	
QEGD2525R/L22	●	●	25x25	150	23.5	4	22	Z*GD**	
QEGD3232R/L13	●	●	32x32	170	30.5	4	13	Z*GD**	
QEGD3232R/L22	●	●	32x32	170	30.5	4	22	Z*GD**	
QEHD2525R/L13	●	●	25x25	150	23	5	13	Z*HD**	
QEHD2525R/L22	●	●	25x25	150	23	5	22	Z*HD**	
QEHD3232R/L13	●	●	32x32	170	30	5	13	Z*HD**	
QEHD3232R/L22	●	●	32x32	170	30	5	22	Z*HD**	
QEKD2525R/L13	●	●	25x25	150	22.6	6	13	Z*KD**	
QEKD2525R/L22	●	●	25x25	150	22.6	6	22	Z*KD**	
QEKD3232R/L13	●	●	32x32	170	29.6	6	13	Z*KD**	
QEKD3232R/L22	●	●	32x32	170	29.6	6	22	Z*KD**	

● Ex stock ○ On demand

\* With internal cooling

System code > A422

Grade selection > A394



Technical info > A501

Cutting data > A456









## Parting & grooving tool holder (external)

Spare parts

	Insert	Z*BD**	Z*ED**	Z*ED**	Z*FD**	Z*FD**	Z*GD**	Z*HD**	Z*KD**
	H	16-20	16	20-32	16	20-32	20-32	20-32	20-32
 Screw		GB70-85-M5×16 (4.0 Nm)	GB70-85-M5×20 (4.0 Nm)	GB70-85-M6×20 (7.0 Nm)	GB70-85-M5×20 (4.0 Nm)	GB70-85-M6×20 (7.0 Nm)	GB70-85-M6×20 (7.0 Nm)	GB70-85-M6×20 (7.0 Nm)	GB70-85-M6×20 (7.0 Nm)
 Wrench		WH40L	WH40L	WH50L	WH40L	WH50L	WH50L	WH50L	WH50L

Insert

						
A399	A400	A401	A404	A407	A410	A411



A414

System code > A422

Grade selection > A394

Technical info > A501

Cutting data > A456

**Parting & grooving tool holder (external)**

QE\*SN30

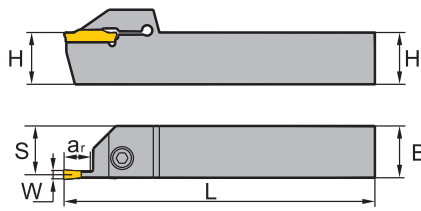
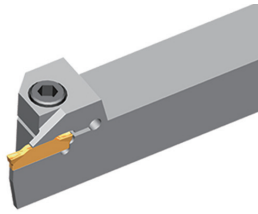

Article	*	Stock	Dimensions [mm]					Inserts
			HxB	L	S	W	ar <sub>max</sub>	
QEHS2525N30		●	25x25	150	12.5	5	30	Z*HS**
QEHS3232N30		●	32x32	170	16	5	30	Z*HS**
QEKS2525N30		○	25x25	150	12.5	6	30	Z*Ks**
QEKS3232N30		○	32x32	170	16	6	30	Z*Ks**

● Ex stock ○ On demand

\* With internal cooling

Spare parts			
	Insert	Z*HS**	Z*Ks**
	H	25-32	25-32
	Screw	GB70-85-M6x20 (7.0 Nm)	GB70-85-M6x20 (7.0 Nm)
	Wrench	WH50L	WH50L

Insert		
A402	A405	A406

System code > A422

Grade selection > A394

Technical info > A501

Cutting data > A456



A

Turning

B

Milling

C

Drilling

D

Technical Information

E

Index

## Parting & grooving tool holder (external)

QECDR/L

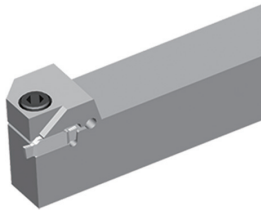

Right hand style

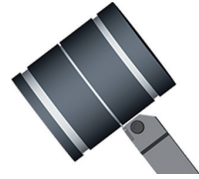
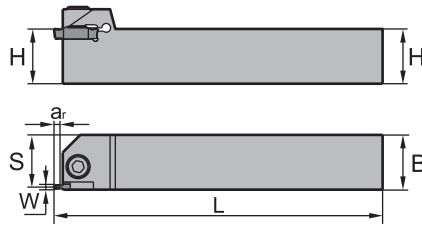

Article	*	Stock		Dimensions [mm]					Inserts
		R	L	HxB	L	S	W	ar <sub>max</sub>	
QECD1616R/L025		○	○	16x16	125	14.75		2.5	Z*CD**
QECD2020R/L025		○	○	20x20	125	18.75		2.5	Z*CD**
QECD2525R/L025		○	○	25x25	150	23.75		2.5	Z*CD**

● Ex stock ○ On demand

\* With internal cooling

### Spare parts

	Insert	Z*CD**	Z*CD**
	H	16	20-32
	Screw	GB70-85-M5x20 (4.0 Nm)	GB70-85-M6x20 (7.0 Nm)
	Wrench	WH40L	WH50L

Insert



A407

System code > A422

Grade selection > A394

Technical info > A501

Cutting data > A456

**Parting & grooving tool holder (external)**

QX\*DR/L

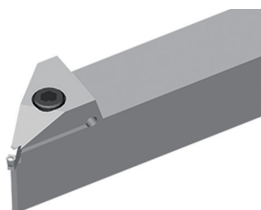

Right hand style

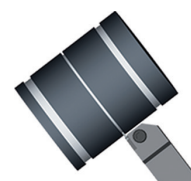
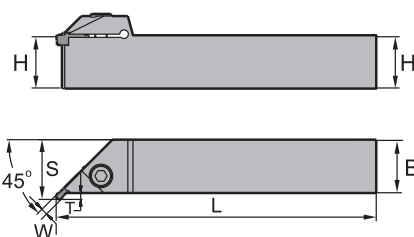

Article	*	Stock		Dimensions [mm]					Inserts
		R	L	HxB	L	S	W	ar <sub>max</sub>	
QXFD2020R/L03-45		○	○	20x20	125	23	3	3	Z*FD**
QXFD2525R/L03-45		●	●	25x25	150	28	3	3	Z*FD**
QXFD3232R/L03-45		○	○	32x32	170	35	3	3	Z*FD**
QXGD2020R/L03-45		○	○	20x20	125	23	4	3	Z*GD**
QXGD2525R/L03-45		○	○	25x25	150	28	4	3	Z*GD**
QXGD3232R/L03-45		○	○	32x32	170	35	4	3	Z*GD**
QXHD2020R/L04-45		○	○	20x20	125	24	5	4	Z*HD**
QXHD2525R/L04-45		○	○	25x25	150	29	5	4	Z*HD**
QXHD3232R/L04-45		○	○	32x32	170	36	5	4	Z*HD**
QXKD2020R/L04-45		○	○	20x20	125	24	6	4	Z*KD**
QXKD2525R/L04-45		○	○	25x25	150	29	6	4	Z*KD**
QXKD3232R/L04-45		○	○	32x32	170	36	6	4	Z*KD**

● Ex stock ○ On demand

\* With internal cooling

Spare parts

	Insert	Z*FD**	Z*GD**	Z*HD**	Z*KD**
	H	20-32	20-32	20-32	20-32
	Screw	GB70-85-M6x20 (7.0 Nm)	GB70-85-M6x20 (7.0 Nm)	GB70-85-M6x20 (7.0 Nm)	GB70-85-M6x20 (7.0 Nm)
	Wrench	WH50L	WH50L	WH50L	WH50L

Insert

A410	A411

System code > A422

Grade selection > A394

Technical info > A501

Cutting data > A456

## Parting & grooving tool holder (external)

QE\*SR/L

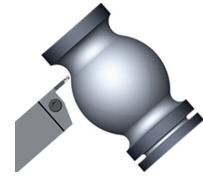
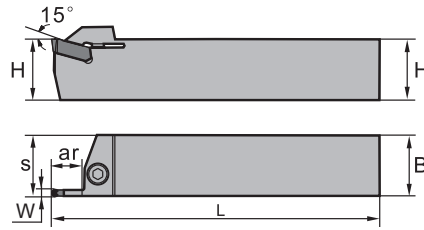
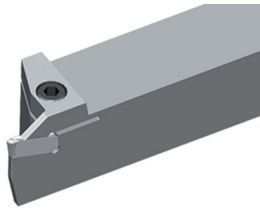

Right hand style

Article	*	Stock		Dimensions [mm]					Inserts
		R	L	HxB	L	S	W	ar <sub>max</sub>	
QEFS2525R/L12-3N		○	○	25x25	150	25.3	3	12	ZI**
QEGS2525R/L12-4N		○	○	25x25	150	25.3	4	12	ZI**
QEHS2525R/L12-5N		○	○	25x25	150	25.4	5	12	ZI**
QEKS2525R/L12-6N		○	○	25x25	150	25.4	6	12	ZI**
QEFS3232R/L22-3N		○	○	32x32	170	32.3	3	22	ZI**
QEGS3232R/L22-4N		○	○	32x32	170	32.3	4	22	ZI**
QEHS3232R/L22-5N		○	○	32x32	170	32.4	5	22	ZI**
QEKS3232R/L22-6N		○		32x32	170	32.4	6	22	ZI**

● Ex stock ○ On demand

\* With internal cooling

### Spare parts

	Insert	ZI**
	<b>H</b>	<b>25-32</b>
	Screw	GB70-85-M6x20 (7.0 Nm)
	Wrench	WH50L

### Insert

A412	A413

System code > A422

Grade selection > A394

Technical info > A501

Cutting data > A456

### Parting blade for external machining

QE\*S\*\*N

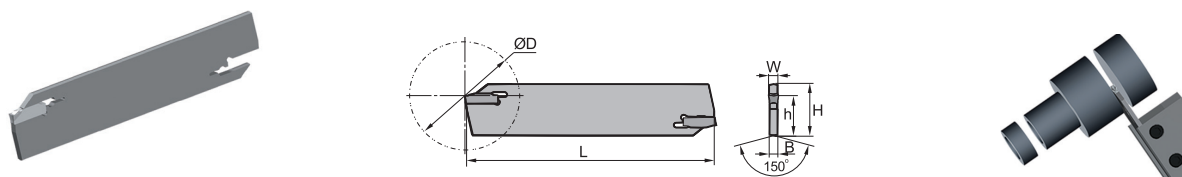

Article	*	Stock	Dimensions [mm]						Inserts
			H	L	h	B	W	ØDmax	
QEES26N	●		26	110	19	2	2.5	60	ZPES**
QEES32N	●		32	150	24.6	2	2.5	100	ZPES**
QEFS26N	●		26	110	19	2.4	3	60	ZPFS**
QEFS32N	●		32	150	24.6	2.4	3	100	ZPFS**
QEGS26N	●		26	110	19	3.2	4	70	ZPGS**
QEGS32N	●		32	150	24.6	3.2	4	120	ZPGS**
QEHS26N	●		26	110	19	4	5	70	ZPHS**
QEHS32N	●		32	150	24.6	4	5	120	ZPHS**
QEKs26N	●		26	110	19	5	6	70	ZPKS**
QEKs32N	●		32	150	24.6	5	6	120	ZPKS**

● Ex stock ○ On demand

\* With internal cooling

Spare parts						
	Insert	ZPES**	ZPFS**	ZPGS**	ZPHS**	ZPKS**
	H	26-32	26-32	26-32	26-32	26-32
	Wrench	W50RL	W50RL	W50RL	W50RL	W50RL

Insert			
A402	A403	A405	A406

System code > A422

Grade selection > A394

Technical info > A501

Cutting data > A456



**A**

## Parting blade for external machining

QE\*S\*\*N-1

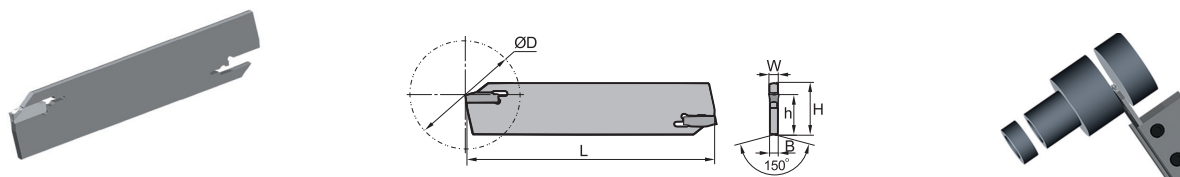

Turning

**B**

Article	*	Stock	Dimensions [mm]						Inserts
			H	L	h	B	W	ØDmax	
QEES26N-1	●		26	110	19	2	2.5	60	ZPES**
QEES32N-1	●		32	150	24.6	2	2.5	100	ZPES**
QEFS26N-1	●		26	110	19	2.4	3	60	ZPFS**
QEFS32N-1	●		32	150	24.6	2.4	3	100	ZPFS**
QEGS26N-1	●		26	110	19	3.2	4	70	ZPGS**
QEGS32N-1	●		32	150	24.6	3.2	4	120	ZPGS**

Milling

**C**

● Ex stock   ○ On demand

\* With internal cooling

Only compatible with clamping blocks of commercially available systems from other manufacturers.

Drilling

Spare parts				
	Insert	ZPES**	ZPFS**	ZPGS**
	H	26-32	26-32	26-32
	Wrench	W50X	W50X	W50X

W50X key must be ordered as an option.

**D**

Insert		
A402	A403	A406

Technical Information

**E**

Index

System code > A422

Grade selection > A394

Technical info > A501

Cutting data > A456

### Clamping block (external)

QZS\*

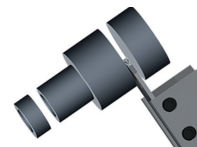
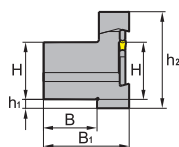
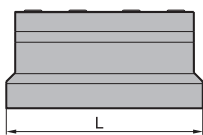
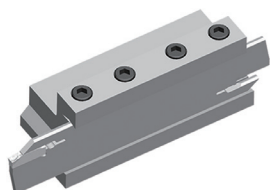

Article	*	Stock	Dimensions [mm]						Inserts
			H	L	h <sub>1</sub>	h <sub>2</sub>	B	B <sub>1</sub>	
QZS2026		●	20	86	10	46.6	19	38	QE**26
QZS2526		●	25	86	5	46.6	23	42	QE**26
QZS3226		○	32	86	3	51.6	30	48	QE**26
QZS2032		●	20	110	13	50	19	38	QE**32
QZS2532		●	25	110	8	50	23	42	QE**32
QZS3232		●	32	110	5	54	30	48	QE**32

● Ex stock ○ On demand

\* With internal cooling

Spare parts			
	Insert	QE**26	QE**32
	H	20-32	20-32
	Clamp	QZC26	QZC32
	Screw	GB70-85-M6×20 (7.0 Nm)	GB70-85-M6×20 (7.0 Nm)
	Wrench	W50RL	W50RL

A

Turning

B

Milling

C

Drilling

D

Technical  
Information

E

Index

## Parting & grooving tool holder (axial)

QF\*\*R/L

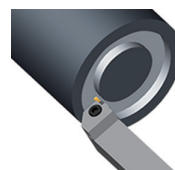
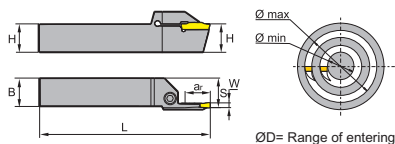
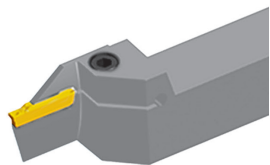

Left hand style

Article	*	Stock		Dimensions [mm]						Inserts
		R	L	HxB	L	S	W	ar <sub>max</sub>	ØD (min-max)	
QFFD2020R/L7-48H	○	○	20x20	150	21	3	7	48-66	Z*FD**	
QFFD2020R/L7-60H	○	○	20x20	150	21	3	7	60-80	Z*FD**	
QFFD2020R/L7-74H	○	○	20x20	150	21	3	7	74-110	Z*FD**	
QFFD2020R/L7-100H	○	○	20x20	150	21	3	7	100-150	Z*FD**	
QFFD2020R/L10-48H	○	○	20x20	150	21	3	10	48-66	Z*FD**	
QFFD2020R/L10-60H	○	○	20x20	150	21	3	10	60-80	Z*FD**	
QFFD2020R/L10-74H	○	○	20x20	150	21	3	10	74-110	Z*FD**	
QFFD2020R/L10-100H	○	○	20x20	150	21	3	10	100-150	Z*FD**	
QFFD2525R/L10-48H	●	●	25x25	150	26	3	10	48-66	Z*FD**	
QFFD2525R/L10-60H	●	●	25x25	150	26	3	10	60-80	Z*FD**	
QFFD2525R/L10-74H	●	●	25x25	150	26	3	10	74-110	Z*FD**	
QFFD2525R/L10-100H	●	●	25x25	150	26	3	10	100-150	Z*FD**	
QFFD2525R/L17-48H	●	●	25x25	150	26	3	17	48-66	Z*FD**	
QFFD2525R/L17-60H	●	●	25x25	150	26	3	17	60-80	Z*FD**	
QFFD2525R/L17-74H	●	●	25x25	150	26	3	17	74-110	Z*FD**	
QFFD2525R/L17-100H	●	●	25x25	150	26	3	17	100-150	Z*FD**	
QFGD2020R/L10-52H	○	○	20x20	150	21	4	10	52-72	Z*GD**	
QFGD2020R/L10-64H	○	○	20x20	150	21	4	10	64-100	Z*GD**	
QFGD2020R/L10-90H	○	○	20x20	150	21	4	10	90-140	Z*GD**	
QFGD2020R/L10-130H	○	○	20x20	150	21	4	10	130-230	Z*GD**	
QFGD2020R/L15-52H	○	○	20x20	150	21	4	15	52-72	Z*GD**	
QFGD2020R/L15-64H	○	○	20x20	150	21	4	15	64-100	Z*GD**	
QFGD2020R/L15-90H	○	○	20x20	150	21	4	15	90-140	Z*GD**	
QFGD2020R/L15-130H	○	○	20x20	150	21	4	15	130-230	Z*GD**	
QFGD2525R/L13-52H	●	●	25x25	150	26	4	13	52-72	Z*GD**	
QFGD2525R/L13-64H	●	●	25x25	150	26	4	13	64-100	Z*GD**	
QFGD2525R/L13-90H	●	●	25x25	150	26	4	13	90-140	Z*GD**	
QFGD2525R/L13-130H	●	●	25x25	150	26	4	13	130-230	Z*GD**	
QFGD2525R/L22-52H	●	●	25x25	150	26	4	22	52-72	Z*GD**	
QFGD2525R/L22-64H	●	●	25x25	150	26	4	22	64-100	Z*GD**	
QFGD2525R/L22-90H	●	●	25x25	150	26	4	22	90-140	Z*GD**	
QFGD2525R/L22-130H	●	●	25x25	150	26	4	22	130-230	Z*GD**	
QFHD2525R/L13-58H	●	●	25x25	150	26	5	13	58-96	Z*HD**	
QFHD2525R/L13-86H	●	●	25x25	150	26	5	13	86-140	Z*HD**	
QFHD2525R/L13-130H	●	●	25x25	150	26	5	13	130-200	Z*HD**	
QFHD2525R/L13-185H	●	●	25x25	150	26	5	13	185-400	Z*HD**	

System code > A422

Grade selection > A394



Technical info > A501







Cutting data > A456

Article	*	Stock		Dimensions [mm]						Inserts
		R	L	HxB	L	S	W	ar <sub>max</sub>	ØD (min-max)	
QFHD2523R/L16-44H		○		25x23	150		5	16	44-52	Z*HD**
QFHD2525R/L22-58H		●	●	25x25	150	26	5	22	58-96	Z*HD**
QFHD2525R/L22-86H		●	●	25x25	150	26	5	22	86-140	Z*HD**
QFHD2525R/L22-130H		●	●	25x25	150	26	5	22	130-200	Z*HD**
QFHD2525R/L22-185H		●	●	25x25	150	26	5	22	185-400	Z*HD**
QFKD2525R/L13-60H		●	●	25x25	150	26	6	13	60-100	Z*KD**
QFKD2525R/L13-88H		○	●	25x25	150	26	6	13	88-180	Z*KD**
QFKD2525R/L13-160H		●	●	25x25	150	26	6	13	160-400	Z*KD**
QFKD2525R/L20-45H			○	25x25	150		6	20	45-90	Z*KD**
QFKD2525R/L22-60H		●	●	25x25	150	26	6	22	60-100	Z*KD**
QFKD2525R/L22-88H		●	●	25x25	150	26	6	22	88-180	Z*KD**
QFKD2525R/L22-160H		●	●	25x25	150	26	6	22	160-400	Z*KD**
QFKD2525R/L30-88H		●		25x25	150		6	30	88-180	Z*KD**

● Ex stock ○ On demand

\* With internal cooling

Spare parts					
	Insert	Z*FD**	Z*GD**	Z*HD**	Z*KD**
	H	20-25	20-25	20-25	20-25
	Screw	GB70-85-M6x20 (7.0 Nm)	GB70-85-M6x20 (7.0 Nm)	GB70-85-M6x20 (7.0 Nm)	GB70-85-M6x20 (7.0 Nm)
	Wrench	W50RL	W50RL	W50RL	W50RL

Insert					
					
A399	A400	A404	A407	A410	A411

System code > A422

Grade selection > A394

Technical info > A501

Cutting data > A456

## Parting & grooving tool holder (axial)

QF\*\*RR/LL

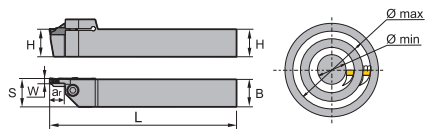
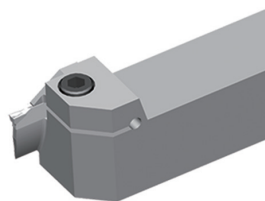

LL Version

Article	*	Stock		Dimensions [mm]						Inserts
		R	L	HxB	L	S	W	ar <sub>max</sub>	ØD (min-max)	
QFFD2020LL10-48H		○		20x20	150	21	3	10	48-66	Z*FD**
QFFD2020RR10-48H		○		20x20	150	21	3	10	48-66	Z*FD**
QFFD2020RR10-60H		○		20x20	150	21	3	10	60-80	Z*FD**
QFFD2020RR10-74H		○		20x20	150	21	3	10	74-110	Z*FD**
QFFD2525LL10-48H			●	25x25	150	26	3	10	48-66	Z*FD**
QFFD2525RR10-48H		○		25x25	150	26	3	10	48-66	Z*FD**
QFFD2525LL10-60H			○	25x25	150	26	3	10	60-80	Z*FD**
QFFD2525RR10-60H		○		25x25	150	26	3	10	60-80	Z*FD**
QFFD2525LL10-74H			○	25x25	150	26	3	10	74-110	Z*FD**
QFFD2525RR10-74H		○		25x25	150	26	3	10	74-110	Z*FD**
QFFD2525LL10-100H			○	25x25	150	26	3	10	100-150	Z*FD**
QFFD2525RR10-100H		○		25x25	150	26	3	10	100-150	Z*FD**
QFFD2525LL17-48H			●	25x25	150	26	3	17	48-66	Z*FD**
QFFD2525RR17-48H		○		25x25	150	26	3	17	48-66	Z*FD**
QFFD2525LL17-60H			○	25x25	150	26	3	17	60-80	Z*FD**
QFFD2525RR17-60H		○		25x25	150	26	3	17	60-80	Z*FD**
QFFD2525LL17-74H			○	25x25	150	26	3	17	74-110	Z*FD**
QFFD2525RR17-74H		○		25x25	150	26	3	17	74-110	Z*FD**
QFFD2525LL17-100H			○	25x25	150	26	3	17	100-150	Z*FD**
QFFD2525RR17-100H		○		25x25	150	26	3	17	100-150	Z*FD**
QFGD2020LL10-52H			○	20x20	150	21	4	10	52-72	Z*GD**
QFGD2020RR10-52H		○		20x20	150	21	4	10	52-72	Z*GD**
QFGD2020LL15-52H			○	20x20	150	26	4	15	52-72	Z*GD**
QFGD2020RR15-52H		○		20x20	150	26	4	15	52-72	Z*GD**
QFGD2020LL15-90H			○	20x20	150	26	4	15	90-140	Z*GD**
QFGD2020RR15-90H		○		20x20	150	26	4	15	90-140	Z*GD**
QFGD2020RR15-130H		○		20x20	150	26	4	15	130-230	Z*GD**
QFGD2525RR13-52H			●	25x25	150	21	4	13	52-72	Z*GD**
QFGD2525LL13-64H			●	25x25	150	21	4	13	64-100	Z*GD**
QFGD2525RR13-64H		○		25x25	150	21	4	13	64-100	Z*GD**
QFGD2525LL13-130H			●	25x25	150	26	4	13	130-230	Z*GD**
QFGD2525RR13-130H		○		25x25	150	21	4	13	130-230	Z*GD**
QFGD2525LL22-52H			○	25x25	150	26	4	22	52-72	Z*GD**
QFGD2525RR22-52H		○		25x25	150	26	4	22	52-72	Z*GD**
QFGD2525LL22-64H			○	25x25	150	26	4	22	64-100	Z*GD**

System code > A422

Grade selection > A394

Technical info > A501



Cutting data > A456

Article	*	Stock		Dimensions [mm]						Inserts 
		R	L	HxB	L	S	W	ar <sub>max</sub>	ØD (min-max)	
QFGD2525RR22-64H	○			25x25	150	26	4	22	64-100	Z*GD**
QFGD2525LL22-90H		○		25x25	150	26	4	22	90-140	Z*GD**
QFGD2525RR22-90H	○			25x25	150	26	4	22	90-140	Z*GD**
QFGD2525LL22-130H		○		25x25	150	26	4	22	130-230	Z*GD**
QFGD2525RR22-130H	●			25x25	150	26	4	22	130-230	Z*GD**
QFHD2525LL13-130H		○		25x25	150	26	5	13	130-200	Z*HD**
QFHD2525RR13-130H	○			25x25	150	26	5	13	130-200	Z*HD**
QFHD2525RR13-185H	○			25x25	150	26	5	13	185-400	Z*HD**
QFHD2525LL22-58H		●		25x25	150	26	5	22	58-96	Z*HD**
QFHD2525RR22-58H	●			25x25	150	26	5	22	58-96	Z*HD**
QFHD2525RR22-86H	○			25x25	150	26	5	22	86-140	Z*HD**
QFHD2525LL22-130H		○		25x25	150	26	5	22	130-200	Z*HD**
QFHD2525RR22-130H	●			25x25	150	26	5	22	130-200	Z*HD**
QFHD2525LL22-185H		○		25x25	150	26	5	22	185-400	Z*HD**
QFHD2525RR22-185H	○			25x25	150	26	5	22	185-400	Z*HD**
QFKD2525RR13-60H	○			25x25	150	26	6	13	60-100	Z*KD**
QFKD2525RR13-88H	○			25x25	150	26	6	13	88-180	Z*KD**
QFKD2525RR15-50H	○			25x25	150		6	15	50-100	Z*KD**
QFKD2525RR22-60H	○			25x25	150	26	6	22	60-100	Z*KD**
QFKD2525LL22-88H		○		25x25	150	26	6	22	88-180	Z*KD**
QFKD2525RR22-88H	○			25x25	150	26	6	22	88-180	Z*KD**
QFKD2525LL22-160H		●		25x25	150	26	6	22	160-400	Z*KD**
QFKD2525RR22-160H	○			25x25	150	26	6	22	160-400	Z*KD**







● Ex stock ○ On demand

\* With internal cooling

Spare parts

	Insert	Z*FD**	Z*GD**	Z*HD**	Z*KD**
	H	20-25	20-25	20-25	20-25
	Screw	GB70-85-M6×20 (7.0 Nm)	GB70-85-M6×20 (7.0 Nm)	GB70-85-M6×20 (7.0 Nm)	GB70-85-M6×20 (7.0 Nm)
	Wrench	W50RL	W50RL	W50RL	W50RL

Insert

					
A399	A400	A404	A407	A410	A411

System code > A422

Grade selection > A394

Technical info > A501

Cutting data > A456

## Parting & grooving tool holder (axial)

QF\*SRR/LL

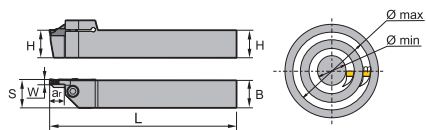
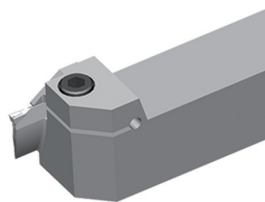

LL Version

Article	*	Stock		Dimensions [mm]						Inserts
		R	L	HxB	L	S	W	ar <sub>max</sub>	ØD (min-max)	
QFHS2525LL30-185H	●			25x25	150	26	5	30	185-400	Z*HS**
QFHS2525RR30-185H	○			25x25	150	26	5	30	185-400	Z*HS**
QFKS2525RR30-160H	○			25x25	150	26	6	30	160-400	Z*KS**
QFKS2525LL30-160H	○			25x25	150	26	6	30	160-400	ZT*S**

● Ex stock ○ On demand

\* With internal cooling

### Spare parts

	Insert	Z*HS**	Z*KS**	ZT*S**
	H	25	25	25
	Screw	GB70-85-M6x20 (7.0 Nm)	GB70-85-M6x20 (7.0 Nm)	GB70-85-M6x20 (7.0 Nm)
	Wrench	W50RL	W50RL	W50RL

### Insert

A402	A405	A406

System code > A422

Grade selection > A394

Technical info > A501

Cutting data > A456

Parting & grooving tool holder (axial)

QF\*DR/L

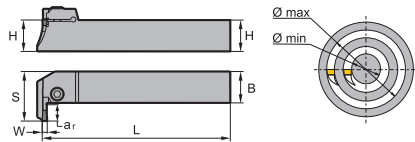
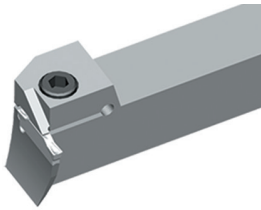

Right hand style

Article	*	Stock		Dimensions [mm]						Inserts
		R	L	HxB	L	S	W	ar <sub>max</sub>	ØD (min-max)	
QFFD2020R/L10-48L	○ ○			20x20	150	31.5	3	10	48-66	Z*FD**
QFGD2020R/L10-52L	○ ○			20x20	150	31.5	4	10	52-72	Z*GD**
QFFD2020R/L10-74L	● ○			20x20	150	31.5	3	10	74-110	Z*FD**
QFGD2020R/L10-90L	● ○			20x20	150	31.5	4	10	90-140	Z*GD**
QFFD2020R/L10-100L	○ ○			20x20	150	31.5	3	10	100-150	Z*FD**
QFGD2020R/L15-52L	○ ○			20x20	150	36.5	4	15	52-72	Z*GD**
QFFD2525R/L10-48L	● ●			25x25	150	36.5	3	10	48-66	Z*FD**
QFFD2525R/L10-60L	● ○			25x25	150	36.5	3	10	60-80	Z*FD**
QFFD2525R/L10-74L	○ ○			25x25	150	36.5	3	10	74-110	Z*FD**
QFFD2525R/L10-100L	○ ○			25x25	150	36.5	3	10	100-150	Z*FD**
QFGD2525R/L13-52L	○ ○			25x25	150	39.5	4	13	52-72	Z*GD**
QFKD2525R/L13-60L	○ ○			25x25	150	39.5	6	13	60-100	Z*KD**
QFGD2525R/L13-64L	○ ●			25x25	150	39.5	4	13	64-100	Z*GD**
QFGD2525R/L13-90L	○ ○			25x25	150	39.5	4	13	90-140	Z*GD**
QFGD2525R/L13-130L	○ ○			25x25	150	39.5	4	13	130-230	Z*GD**
QFFD2525R/L17-48L	○ ○			25x25	150	43.5	3	17	48-66	Z*FD**
QFFD2525R/L17-60L	○ ○			25x25	150	43.5	3	17	60-80	Z*FD**
QFFD2525R/L17-74L	○ ○			25x25	150	43.5	3	17	74-110	Z*FD**
QFFD2525R/L17-100L	● ○			25x25	150	43.5	3	17	100-150	Z*FD**
QFGD2525R/L22-52L	○ ○			25x25	150	48.5	4	22	52-72	Z*GD**
QFKD2525R/L22-60L	○ ●			25x25	150	48.5	6	22	60-100	Z*KD**
QFGD2525R/L22-64L	○ ○			25x25	150	48.5	4	22	64-100	Z*GD**
QFKD2525R/L22-88L	○ ●			25x25	150	48.5	6	22	88-180	Z*KD**
QFGD2525R/L22-90L	○ ○			25x25	150	48.5	4	22	90-140	Z*GD**
QFGD2525R/L22-130L	● ○			25x25	150	48.5	4	22	130-230	Z*GD**
QFFD2020R/L7-74L	○			20x20	150	28.5	3	7	74-110	Z*FD**
QFFD2020R/L10-60L	●			20x20	150	31.5	3	10	60-80	Z*FD**
QFGD2020R/L10-130L	●			20x20	150	31.5	4	10	130-230	Z*GD**
QFGD2020R/L15-64L	○			20x20	150	36.5	4	15	64-100	Z*GD**
QFGD2020R/L15-90L	○			20x20	150	36.5	4	15	90-140	Z*GD**
QFGD2020R/L15-130L	○			20x20	150	36.5	4	15	130-230	Z*GD**
QFHD2525R/L13-58L	○			25x25	150	39.5	5	13	58-96	Z*HD**
QFHD2525R/L13-86L	●			25x25	150	39.5	5	13	86-140	Z*HD**
QFHD2525R/L13-130L	○ ○			25x25	150	39.5	5	13	130-200	Z*HD**
QFHD2525R/L13-185L	○			25x25	150	39.5	5	13	185-400	Z*HD**
QFHD2525R/L22-58L	○ ○			25x25	150	48.5	5	22	58-96	Z*HD**

System code > A422

Grade selection > A394

Technical info > A501

Cutting data > A456



A

Turning

B

Milling

C

Drilling

D

Technical Information

E

Index



**A**

Turning



Article	*	Stock		Dimensions [mm]						Inserts 
		R	L	HxB	L	S	W	ar <sub>max</sub>	ØD (min-max)	
QFHD2525R/L22-86L		○	○	25x25	150	48.5	5	22	86-140	Z*HD**
QFHD2525R/L22-130L		○	○	25x25	150	48.5	5	22	130-200	Z*HD**
QFHD2525R/L22-185L		○	○	25x25	150	48.5	5	22	185-400	Z*HD**
QFKD2525R/L13-88L			○	25x25	150	39.5	6	13	88-180	Z*KD**

● Ex stock    ○ On demand

\* With internal cooling







**B**

Milling

Spare parts					
	Insert H	Z*FD** 20-25	Z*GD** 20-25	Z*HD** 20-25	Z*KD** 20-25
	Screw	GB70-85-M6x20 (7.0 Nm)	GB70-85-M6x20 (7.0 Nm)	GB70-85-M6x20 (7.0 Nm)	GB70-85-M6x20 (7.0 Nm)
	Wrench	W50RL	W50RL	W50RL	W50RL

**C**

Drilling

Insert					
					
A399	A400	A404	A407	A410	A411

**D**

Technical Information

**E**

Index

System code > A422

Grade selection > A394

Technical info > A501

Cutting data > A456

**Parting & grooving tool holder (axial)**

QFHSDR/L

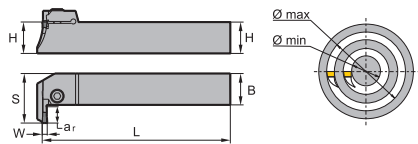
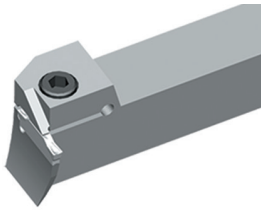



Right hand style

Article	*	Stock		Dimensions [mm]						Inserts
		R	L	HxB	L	S	W	ar <sub>max</sub>	ØD (min-max)	
QFHS2525R/L30-185L		○	○	25x25	150	56.5	5	30	185-400	Z*HS**

● Ex stock ○ On demand

\* With internal cooling

Spare parts

	Insert	Z*HS**
	H	25
	Screw	GB70-85-M6x20 (7.0 Nm)
	Wrench	W50RL

Insert

		
A402	A405	A406

System code > A422

Grade selection > A394

Technical info > A501

Cutting data > A456

## Parting & grooving tool holder (axial)

QF\*\*R/L

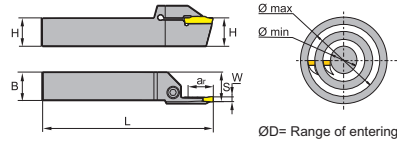
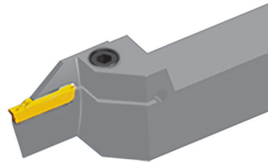

Left hand style

Article	*	Stock		Dimensions [mm]						Inserts
		R	L	HxB	L	S	W	ar <sub>max</sub>	ØD (min-max)	
QFHS2525R/L30-185H	•	•	25x25	150	26	5	30	185-400	Z*HS**	
QFKS2525R/L30-160H	•	•	25x25	150	26	6	30	160-400	Z*KS**	

• Ex stock    ○ On demand

\* With internal cooling

### Spare parts

	Insert	Z*HS**	Z*KS**
	H	25	25
	Screw	GB70-85-M6x20 (7.0 Nm)	GB70-85-M6x20 (7.0 Nm)
	Wrench	W50RL	W50RL

### Insert

A402	A405	A406

System code > A422

Grade selection > A394

Technical info > A501

Cutting data > A456

**Parting & grooving tool holder (external)**

C40X-Q\*DR/L

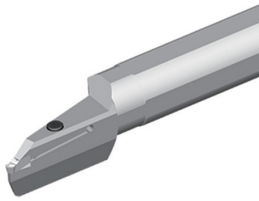

Right hand style

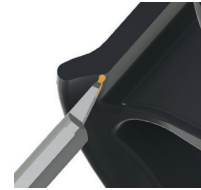
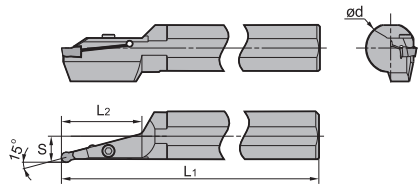

Article	*	Stock		Dimensions [mm]					Inserts
		R	L	ØD	ød	S	L <sub>1</sub>	L <sub>2</sub>	
C40X-QKDR/L60-15A		○	○	160	40	20	320	60	Z*KD**
C40X-QKDR/L75-15A		●	○	160	40	20	320	75	Z*KD**
C40X-QLDR/L65-15A		○	○	160	40	21	320	65	Z*LD**
C40X-QLDR/L80-15A		○	○	160	40	21	320	80	Z*LD**

● Ex stock ○ On demand

\* With internal cooling

Spare parts			
	Insert	Z*KD**	Z*LD**
	Ød	<b>32-40</b>	<b>32-40</b>
	Screw	GB70-85-M6×20 (7.0 Nm)	GB70-85-M6×20 (7.0 Nm)
	Wrench	WH50L	WH50L

Insert		
A410	A411	A414

System code > A422

Grade selection > A394

Technical info > A501

Cutting data > A456

## Parting & grooving tool holder (internal)

C\*\*\*-Q\*DR/L

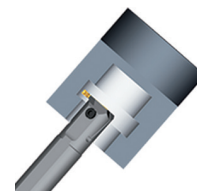
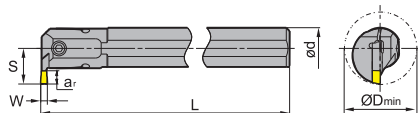
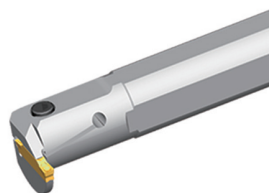

Article	*	Stock		Dimensions [mm]						Inserts
		R	L	ØDmin	ød	L	S	W	ar <sub>max</sub>	
C16M-QBDR/L04-20	● ○	●	○	20	16	150		2	4	Z*BD**
C20Q-QEDR/L05-27	● ●	●	●	27	20	180		2.5	5	Z*ED**
C25R-QEDR/L07-33	● ●	●	●	33	25	200		2.5	7	Z*ED**
C32S-QEDR/L09-42	● ●	●	●	42	32	250		2.5	9	Z*ED**
C20Q-QFDR/L05-27	● ●	●	●	27	20	0		3	5	Z*FD**
C25R-QFDR/L07-33	● ●	●	●	33	25	200		3	7	Z*FD**
C32S-QFDR/L09-42	● ●	●	●	42	32	250		3	9	Z*FD**
C25R-QGDR/L08-35	● ●	●	●	35	25	200		4	8	Z*GD**
C32S-QGDR/L11-44	● ●	●	●	44	32	250		4	11	Z*GD**
C40T-QGDR/L13-54	● ●	●	●	5	40	300		4	13	Z*GD**
C25R-QHDR/L08-35	● ●	●	●	35	25	200		5	8	Z*HD**
C32S-QHDR/L11-44	● ●	●	●	44	32	250		5	11	Z*HD**
C40T-QHDR/L13-54	● ●	●	●	54	40	300		5	13	Z*HD**
C25R-QKDR/L08-35	○ ●	○	●	35	25	200		6	8	Z*KD**
C32S-QKDR/L11-44	● ●	●	●	44	32	250		6	11	Z*KD**
C40T-QKDR/L13-54	● ●	●	●	54	40	300		6	13	Z*KD**

● Ex stock ○ On demand

\* With internal cooling

### Spare parts

	Insert	Z*BD**	Z*ED**	Z*ED**	Z*ED**	Z*FD**	Z*FD**	Z*FD**	Z*GD**	Z*GD**	Z*HD**	Z*HD**	Z*KD**	Z*KD**
		Ød	16	20	25	32-40	20	25	32-40	25	32-40	25	32-40	25
	Screw	GB70-85-M5x10 (4.0 Nm)	GB70-85-M4x12 (2.6 Nm)	GB70-85-M5x16 (4.0 Nm)	GB70-85-M6x20 (7.0 Nm)	GB70-85-M4x12 (2.6 Nm)	GB70-85-M5x16 (4.0 Nm)	GB70-85-M6x20 (7.0 Nm)	GB70-85-M5x16 (4.0 Nm)	GB70-85-M6x20 (7.0 Nm)	GB70-85-M5x16 (4.0 Nm)	GB70-85-M6x20 (7.0 Nm)	GB70-85-M5x16 (4.0 Nm)	GB70-85-M6x20 (7.0 Nm)
	Wrench	WH40L	WH30L	WH40L	WH50L	WH30L	WH40L	WH50L	WH40L	WH50L	WH40L	WH50L	WH40L	WH50L







System code > A422

Grade selection > A394

Technical info > A501

Cutting data > A456

**Parting & grooving tool holder (internal)**

Insert						
						
A399	A400	A404	A407	A410	A411	A414

**A**

Turning

**B**

Milling

**C**

Drilling

**D**

Technical  
Information

**E**

Index

System code > A422

Grade selection > A394

Technical info > A501

Cutting data > A456

## Parting & grooving tool holder (external)

QE\*\*R/L-DGC

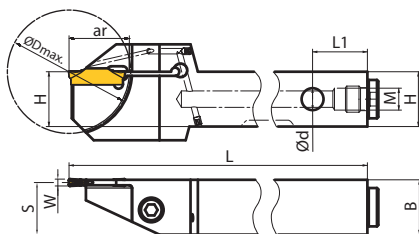
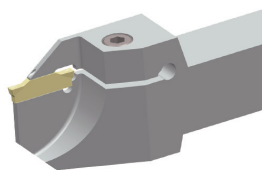

Article	*	Stock		Dimensions [mm]									Inserts
		R	L	HxB	ød	L	S	L <sub>1</sub>	W	ar <sub>max</sub>	ØD <sub>max</sub>	M	
QEED1616R/L20-DGC	*	○	○	16x16	G1/8	96	15	20	2	20	40	G1/8	Z*BD**
QEED1616R/L30-DGC	*	●	●	16x16	G1/8	105	15	20	2	30	60	G1/8	Z*BD**
QEED2020R/L20-DGC	*	○	○	20x20	G1/8	111	19	20	2	20	40	G1/8	Z*BD**
QEED2020R/L30-DGC	*	●	●	20x20	G1/8	120	19	20	2	30	60	G1/8	Z*BD**
QEED2525R/L20-DGC	*	○	○	25x25	G1/8	126	24	20	2	20	40	G1/8	Z*BD**
QEED2525R/L30-DGC	*	●	●	25x25	G1/8	135	24	20	2	30	60	G1/8	Z*BD**
QEED1616R/L20-DGC	*	○	○	16x16	G1/8	96	14.75	20	2.5	20	40	G1/8	Z*ED**
QEED1616R/L30-DGC	*	●	●	16x16	G1/8	105	14.75	20	2.5	30	60	G1/8	Z*ED**
QEED2020R/L20-DGC	*	○	○	20x20	G1/8	111	18.75	20	2.5	20	40	G1/8	Z*ED**
QEED2020R/L30-DGC	*	●	○	20x20	G1/8	120	18.75	20	2.5	30	60	G1/8	Z*ED**
QEED2525R/L20-DGC	*	○	○	25x25	G1/8	126	23.75	20	2.5	20	40	G1/8	Z*ED**
QEED2525R/L30-DGC	*	○	○	25x25	G1/8	135	23.75	20	2.5	30	60	G1/8	Z*ED**
QEFD1616R/L20-DGC	*	○	○	16x16	G1/8	96	14.5	20	3	20	40	G1/8	Z*FD**
QEFD1616R/L30-DGC	*	●	●	16x16	G1/8	105	14.5	20	3	30	60	G1/8	Z*FD**
QEFD2020R/L20-DGC	*	○	○	20x20	G1/8	111	18.5	20	3	20	40	G1/8	Z*FD**
QEFD2020R/L30-DGC	*	●	●	20x20	G1/8	120	18.5	20	3	30	60	G1/8	Z*FD**
QEFD2525R/L20-DGC	*	○	○	25x25	G1/8	126	23.5	20	3	20	40	G1/8	Z*FD**
QEFD2525R/L30-DGC	*	○	○	25x25	G1/8	135	23.5	20	3	30	60	G1/8	Z*FD**
QEGD1616R/L20-DGC	*	○	○	16x16	G1/8	96	14	20	4	20	40	G1/8	Z*GD**
QEGD1616R/L30-DGC	*	●	●	16x16	G1/8	105	14	20	4	30	60	G1/8	Z*GD**
QEGD2020R/L20-DGC	*	○	○	20x20	G1/8	111	18	20	4	20	40	G1/8	Z*GD**
QEGD2020R/L30-DGC	*	○	○	20x20	G1/8	120	18	20	4	30	60	G1/8	Z*GD**
QEGD2525R/L20-DGC	*	○	○	25x25	G1/8	126	23	20	4	20	40	G1/8	Z*GD**
QEGD2525R/L30-DGC	*	○	○	25x25	G1/8	135	23	20	4	30	60	G1/8	Z*GD**

● Ex stock ○ On demand

\* With internal cooling

### Spare parts

	Insert	Z*BD**	Z*ED**	Z*FD**	Z*GD**
		H	16-25	16-25	16-25
	Grub screw	PT1/8x4	PT1/8x4	PT1/8x4	PT1/8x4
	Screw	GB70-85-M5x20 (4.0 Nm)	GB70-85-M5x20 (4.0 Nm)	GB70-85-M5x20 (4.0 Nm)	GB70-85-M5x20 (4.0 Nm)
	Wrench	WH40L	WH40L	WH40L	WH40L
	Wrench	WH50L	WH50L	WH50L	WH50L





System code > A422

Grade selection > A394

Technical info > A501

Cutting data > A456

## Parting & grooving tool holder (external)

Insert			
			
A399	A400	A404	A407

**A**

Turning

**B**

Milling

**C**

Drilling

**D**

Technical  
Information

**E**

Index

System code > A422

Grade selection > A394

Technical info > A501

Cutting data > A456



## Parting & grooving tool holder (external)

QE\*\*R/L-DGSC

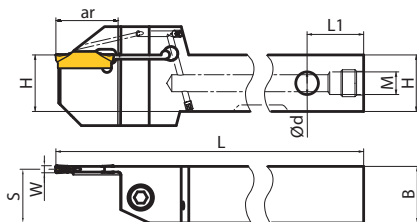
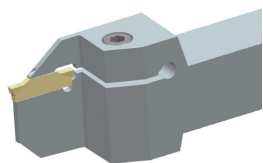

Article	*	Stock		Dimensions [mm]								Inserts
		R	L	HxB	ød	L	S	L <sub>1</sub>	W	ar <sub>max</sub>	M	
QEED1616R/L30-DGSC	*	●	●	16x16	G1/8	105	14.75	20	2.5	30	G1/8	Z*ED**
QEED2020R/L30-DGSC	*	●	○	20x20	G1/8	120	18.75	20	2.5	30	G1/8	Z*ED**
QEED2525R/L30-DGSC	*	○	○	25x25	G1/8	135	23.75	20	2.5	30	G1/8	Z*ED**
QEFD1616R/L30-DGSC	*	●	●	16x16	G1/8	105	14.5	20	3	30	G1/8	Z*FD**
QEFD2020R/L30-DGSC	*	○	○	20x20	G1/8	120	18.5	20	3	30	G1/8	Z*FD**
QEFD2525R/L30-DGSC	*	○	○	25x25	G1/8	135	23.5	20	3	30	G1/8	Z*FD**
QEGD1616R/L30-DGSC	*	○	○	16x16	G1/8	105	14	20	4	30	G1/8	Z*GD**
QEGD2020R/L30-DGSC	*	○	○	20x20	G1/8	120	18	20	4	30	G1/8	Z*GD**
QEGD2525R/L30-DGSC	*	○	○	25x25	G1/8	135	23	20	4	30	G1/8	Z*GD**
QEHD2525R/L30-DGSC	*	○	○	25x25	G1/8	135	22.5	20	5	30	G1/8	Z*HD**
QEKD2525R/L30-DGSC	*	○	○	25x25	G1/8	135	22	20	6	30	G1/8	Z*KD**

● Ex stock ○ On demand

\* With internal cooling

### Spare parts

	Insert H	Z*ED** 16-25	Z*FD** 16-25	Z*GD** 20-25	Z*HD** 20-25	Z*KD** 20-25
	Grub screw	PT1/8x4	PT1/8x4	PT1/8x4	PT1/8x4	PT1/8x4
	Screw	GB70-85-M5x20 (4.0 Nm)	GB70-85-M5x20 (4.0 Nm)	GB70-85-M5x20 (4.0 Nm)	GB70-85-M6x20 (7.0 Nm)	GB70-85-M6x20 (7.0 Nm)
	Wrench	WH40L	WH40L	WH40L	WH50L	WH50L
	Wrench	WH50L	WH50L	WH50L	WH50L	WH50L

### Insert

A399	A400	A404	A407

System code > A422

Grade selection > A394

Technical info > A501

Cutting data > A456

## Parting & grooving tool holder (external)

QE\*\*R/L-SC

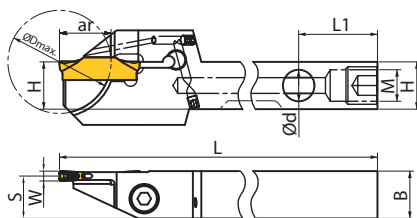
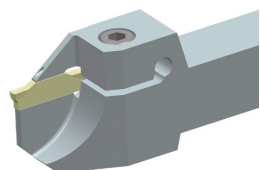

Article	*	Stock		Dimensions [mm]									Inserts
		R	L	HxB	ød	L	S	L <sub>1</sub>	W	ar <sub>max</sub>	ØD <sub>max</sub>	M	
QEAD1010R/L10-SC	*	○	○	10x10	G1/16	125	9	20	1.5	10	20	G1/16	Z*AD**
QEAD1212R/L13-SC	*	○	○	12x12	G1/8	125	12	20	1.5	13	26	G1/8	Z*AD**
QEAD1616R/L13-SC	*	○	○	16x16	G1/8	125	15	20	1.5	13	26	G1/8	Z*AD**
QEAD2020R/L13-SC	*	○	○	20x20	G1/8	125	19	20	1.5	13	26	G1/8	Z*AD**
QEBD1010R/L10-SC	*	○	○	10x10	G1/16	110	9	20	2	10	20	G1/16	Z*BD**
QEBD1212R/L13-SC	*	●	●	12x12	G1/8	110	11	20	2	13	26	G1/8	Z*BD**
QEBD1616R/L13-SC	*	●	●	16x16	G1/8	110	15	20	2	13	26	G1/8	Z*BD**
QEBD2020R/L13-SC	*	○	○	20x20	G1/8	110	19	20	2	13	26	G1/8	Z*BD**
QEED1010R/L10-SC	*	○	○	10x10	G1/16	110	8.75	20	2.5	10	20	G1/16	Z*ED**
QEED1212R/L13-SC	*	●	●	12x12	G1/8	110	10.75	20	2.5	13	26	G1/8	Z*ED**
QEED1616R/L17-SC	*	●	●	16x16	G1/8	110	14.75	20	2.5	17	34	G1/8	Z*ED**
QEED2020R/L17-SC	*	●	●	20x20	G1/8	110	18.75	20	2.5	17	34	G1/8	Z*ED**
Qefd1212R/L13-SC	*	●	●	12x12	G1/8	110	10.5	20	3	13	26	G1/8	Z*FD**
Qefd1616R/L17-SC	*	●	●	16x16	G1/8	110	14.5	20	3	17	34	G1/8	Z*FD**
Qefd2020R/L22-SC	*	●	●	20x20	G1/8	110	18.5	20	3	22	44	G1/8	Z*FD**

● Ex stock ○ On demand

\* With internal cooling

### Spare parts

Insert	H	Z*AD**	Z*AD**	Z*AD**	Z*AD**	Z*BD**	Z*BD**	Z*BD**	Z*ED**	Z*ED**	Z*ED**	Z*FD**	Z*FD**
		10	12	16	20	10	12	16-20	10	12	16-20	12	16-20
	Grub screw	PT1/16x6	PT1/8x4	PT1/8x4	PT1/8x4	PT1/16x6	PT1/8x4	PT1/8x4	PT1/16x6	PT1/8x4	PT1/8x4	PT1/8x4	PT1/8x4
	Screw	GB70-85-M4x12 (2.6 Nm)	GB70-85-M4x12 (2.6 Nm)	GB70-85-M4x14	GB70-85-M4x18	GB70-85-M4x12 (2.6 Nm)	GB70-85-M4x12 (2.6 Nm)	GB70-85-M6x20 (7.0 Nm)	GB70-85-M4x12 (2.6 Nm)	GB70-85-M4x12 (2.6 Nm)	GB70-85-M6x20 (7.0 Nm)	GB70-85-M4x12 (2.6 Nm)	GB70-85-M5x20 (4.0 Nm)
	Wrench	WH30L	WH30L	WH30L	WH30L	WH30L	WH30L	WH40L	WH30L	WH30L	WH40L	WH30L	WH40L
	Wrench	WH40L	WH50L	WH50L	WH50L	WH40L	WH50L	WH50L	WH40L	WH50L	WH50L	WH50L	WH50L

System code > A422

Grade selection > A394





Technical info > A501

Cutting data > A456



**A**

## Parting & grooving tool holder (external)

Insert			
			
A399	A400	A404	A407

Turning

**B**

Milling

**C**

Drilling

**D**

Technical  
Information

**E**

Index

System code > A422

Grade selection > A394

Technical info > A501

Cutting data > A456

## Accessoires

### Coolant hose



Article	Dimensions [mm]			Stock
	L	Th1	Th2	
HOSE G1/8-7/16/200BS	200	G1/8"-28 BSPP	G1/8"-28 BSPP	○
HOSE G1/8-7/16/300BS	300	G1/8"-28 BSPP	G1/8"-28 BSPP	○
HOSE G1/8-7/16/200BB	200	G1/8"-28 BSPP	G1/8"-28 BSPP	○
HOSE G1/8-7/16/300BB	300	G1/8"-28 BSPP	G1/8"-28 BSPP	○

● Ex stock   ○ On demand

### Coolant connection

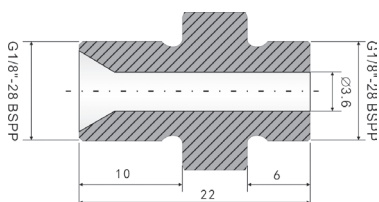

Article	Stock
NIPPLE G1/8- G1/8	○

● Ex stock   ○ On demand

**A**

Turning

**B**

Milling

**C**

Drilling

**D**

Technical Information

**E**

Index

## External tool holders – QC series

**GQC R 20 20 K 22 – 15**

1 2 3 4 5 6 7

Series	Type		Height [mm]		Width [mm]		Length [mm]	
	Code	Description	Code	Description	Code	Description	Code	Description
	R	Right	16	16	16	16	K	125
L	Left	20	20	20	20	M	150	
		25	25	25	25			

1 2 3 4 5

Cutting edge length [mm]	
Code	I.C
11	6,35
16	9,252
22	12,70

6

Cutting width range [mm]		
Code	Insert size	
15	0,5 ≤ S < 1,8 (QC16***)	1,0 ≤ S < 2,3 (QC22***)
25	1,8 ≤ S < 3,0 (QC16***)	2,3 ≤ S < 3,3 (QC22***)
35	–	3,3 ≤ S ≤ 4,8 (QC22***)

7

## Boring bars – QC series

**S 20 K – QC 16 15 R 25**

1 2 3 4 5 6 7 8

Shank type	
Code	Material
S	Steel shank
C	Solid carbide shank
A	Solid carbide shank (IC)

1

Diameter [mm]	
Code	Description
16	16
20	20
25	25

2

Length [mm]	
Code	Description
H	100
K	125
M	150

3

Series	Cutting edge length [mm]	
	Code	I.C
	11	6,35
16	9,252	
22	12,70	

4

5

Cutting width range [mm]			
Code	Insert size		
15	0,5 ≤ S < 1,8 (QC11***)	0,5 ≤ S < 1,8 (QC16***)	1,0 ≤ S < 2,3 (QC22***)
25	1,8 ≤ S < 3,0 (QC11***)	1,8 ≤ S < 3,0 (QC16***)	2,3 ≤ S < 3,3 (QC22***)
35	–	–	3,3 ≤ S ≤ 4,8 (QC22***)

6

Cutting direction	
Code	Description
R	Right
L	Left

7

Starting diameter [mm]			
Code	∅	Code	∅
16	16	25	25
20	20	35	35

8

Grooving (external)

GQC\*\*R/L

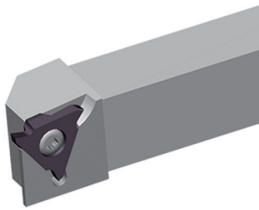

Right hand style

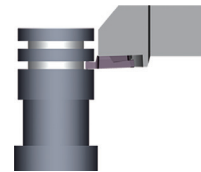
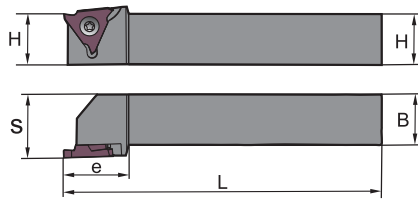



Article	*	Stock		Dimensions [mm]						Inserts
		R	L	H	L	S	e	B	Width	
GQCR/L1616K16-15	●	●	16	125	21	25.5	16	0.5-1.80	QC16R/L 050-180	
GQCR/L2020K16-15	○	●	20	125	25	25.5	20	0.5-1.80	QC16R/L 050-180	
GQCR/L2525M16-15	○	●	25	150	30	25.5	25	0.5-1.80	QC16R/L 050-180	
GQCR/L1616K16-25	●	●	16	125	21	25.5	16	1.8-3.0	QC16R/L 180-300	
GQCR/L2020K16-25	○	●	20	125	25	25.5	20	1.8-3.0	QC16R/L 180-300	
GQCR/L2525M16-25	○	●	25	150	30	25.5	25	1.8-3.0	QC16R/L 180-300	
GQCR/L2020K22-15	○	●	20	125	25	25.5	20	1.0-2.3	QC22R/L 100-230	
GQCR/L2525M22-15	○	●	25	150	30	25.5	25	1.0-2.3	QC22R/L 100-230	
GQCR/L2020K22-25	○	●	20	125	25	25.5	20	2.3-3.3	QC22R/L 230-330	
GQCR/L2525M22-25	○	●	25	150	30	25.5	25	2.3-3.3	QC22R/L 230-330	
GQCR/L2020K22-35	●	●	20	125	25	25.5	20	3.3-4.8	QC22R/L 330-480	
GQCR/L2525M22-35	●	●	25	150	30	25.5	25	3.3-4.8	QC22R/L 330-480	

● Ex stock ○ On demand

\* With internal cooling

Spare parts

	Insert	QC16R/L 050-180	QC16R/L 180-300	QC22R/L 100-230	QC22R/L 230-330	QC22R/L 330-480
	H	16-32	16-32	16-32	16-32	16-32
	Screw	I60M3.5×10 (2.7 Nm)	I60M3.5×10 (2.7 Nm)	I60M5×13 (6.7 Nm)	I60M5×13 (6.7 Nm)	I60M5×13 (6.7 Nm)
	Wrench (shim)	WT15IP	WT15IP	WT20IP	WT20IP	WT20IP

Insert



Medium Cut

A417

S\_QCR/L

S\*K-QC\*\*R/L

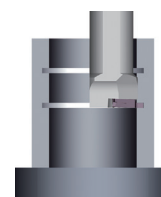
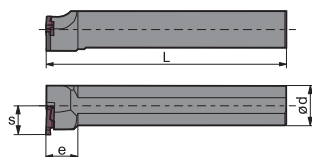
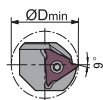
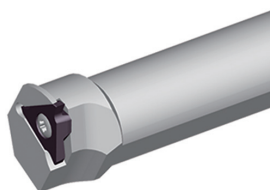

Right hand style

Article	*	Stock		Dimensions [mm]						Inserts
		R	L	ØDmin	ød	L	S	e	Width	
S16H-QC1115R/L20	•	•		21	16	100	11.5	12	0.5-1.80	QC11R/L 050-180
S20K-QC1115R/L16	•	•		16	20	125	11.1	40	0.5-1.80	QC11R/L 050-180
S16H-QC1125R/L20	•	•		21	16	100	11.5	12	1.8-3.0	QC11R/L 180-300
S20K-QC1125R/L16	○	○		16	20	125	11.1	40	1.8-3.0	QC11R/L 180-300
S20M-QC1615R/L25	○	•		26	20	150	12.5	15	0.5-1.80	QC16R/L 050-180
S20M-QC1625R/L25	•	•		26	20	150	12.5	15	1.8-3.0	QC16R/L 180-300
S25M-QC2215R/L35	•	•		35	25	150	18.2	15	1.0-2.3	QC22R/L 100-230
S25M-QC2225R/L35	•	•		35	25	150	18.2	20	2.3-3.3	QC22R/L 230-330
S25M-QC2235R/L35	○	•		35	25	150	18.2	20	3.3-4.8	QC22R/L 330-480

• Ex stock    ○ On demand

\* With internal cooling

Right-hand tool holder for left-hand grooving insert.

Left-hand tool holder for right-hand grooving insert.

Spare parts

	Insert	QC11R/L 050-180	QC11R/L 180-300	QC16R/L 050-180	QC16R/L 180-300	QC22R/L 100-230	QC22R/L 230-330	QC22R/L 330-480
	ød	16-20	16-20	20	20	25	25	25
	Screw	I60M2.5×6.5 (1.0 Nm)	I60M2.5×6.5 (1.0 Nm)	I60M3.5×10 (2.7 Nm)	I60M3.5×10 (2.7 Nm)	I60M5×13 (6.7 Nm)	I60M5×13 (6.7 Nm)	I60M5×13 (6.7 Nm)
	Wrench (shim)	WT07IP	WT07IP	WT15IP	WT15IP	WT20IP	WT20IP	WT20IP

Insert



Medium Cut

A417

System code > A452

Grade selection > A394

Technical info > A501

Cutting data > A456

Notes

.....

.....

.....

.....

.....

.....

.....

.....

.....

.....

.....

.....

.....

.....

.....

.....

.....

.....

.....

.....

.....

.....

.....

**A**

Turning

**B**

Milling

**C**

Drilling

**D**

Technical  
Information

**E**

Index



## Parting & grooving inserts

	Material group	Composition / structure / heat treatment		Brinell hardness HB	Machining group	Starting values for cutting speed vc [m/min]			
						HC (CVD)		HC (PVD)	
						YBC252	YBG102	YBG105	
<b>A</b> Turning	<b>P</b> Unalloyed steel	approx. 0,15 % C	annealed	125	1	190			
		approx. 0,45 % C	annealed	190	2	175			
		approx. 0,45 % C	tempered	250	3	145			
		approx. 0,75 % C	annealed	270	4	140			
		approx. 0,75 % C	tempered	300	5	135			
	<b>B</b> Milling	Low-alloyed steel		annealed	180	6	170		
				tempered	275	7	125		
				tempered	300	8	115		
				tempered	350	9	105		
	<b>C</b> Drilling	High-alloyed steel and high-alloyed tool steel		annealed	200	10	125		
			hardened and tempered	325	11	95			
<b>M</b> Stainless steel		ferritic/martensitic	annealed	200	12	165	165	170	
		martensitic	tempered	240	13	135	135	140	
		austenitic	quench hardened	180	14	155	155	160	
		austenitic-ferritic		230	15	135	135	140	
<b>K</b> Cast iron with spheroidal graphite		Grey cast iron	perlitic/ferritic		180	16	240		
			perlitic (martensitic)		260	17	185		
		Cast iron with spheroidal graphite	ferritic		160	18	220		
			perlitic		250	19	165		
	Malleable cast iron	ferritic		130	20	175			
		perlitic		230	21	165			
<b>N</b> Drilling	Aluminium wrought alloys	cannot be hardened		60	22				
		hardenable	hardened	100	23				
	Cast aluminium alloys	≤ 12% Si, cannot be hardened		75	24				
		≤ 12% Si, hardenable	hardened	90	25				
		> 12% Si, cannot be hardened		130	26				
	Copper and copper alloys (bronze/brass)	machining steel, PB> 1%		110	27				
		CuZn, CuSnZn		90	28				
CuSn, Pb-free copper, electrolytic copper		100	29						
<b>D</b> Technical Information	<b>S</b> Heat-resistant alloys	Fe-based alloys	annealed	200	30		95	100	
			hardened	280	31		50	50	
		Ni or Co bass	annealed	250	32		80	80	
			hardened	350	33		70	70	
			cast	320	34		70	70	
	Titanium alloys	pure titanium		R <sub>m</sub> 400	35		145	150	
		α and β alloys	hardened	R <sub>m</sub> 1050	36		50	50	
<b>E</b> Index	<b>H</b> Hardened steel		hardened and tempered	55 HRC	37				
			hardened and tempered	60 HRC	38				
		Hard cast iron	cast	400	39				
		Hardened cast iron	hardened and tempered	55 HRC	40				
<b>X</b> Non-metallic materials	Thermoplasts			41					
	Thermosetting plastics			42					
	Plastic, glass-fibre reinforced GFRP			43					
	Plastic, carbon fibre reinforced CFRP			44					
	Graphite			45					
	Wood			46					

Note: The given cutting values are guide values, which were determined under ideal conditions.  
The values have to be adapted in individual cases.  
For examples of material for cutting tool groups view page D11.



# THREADING

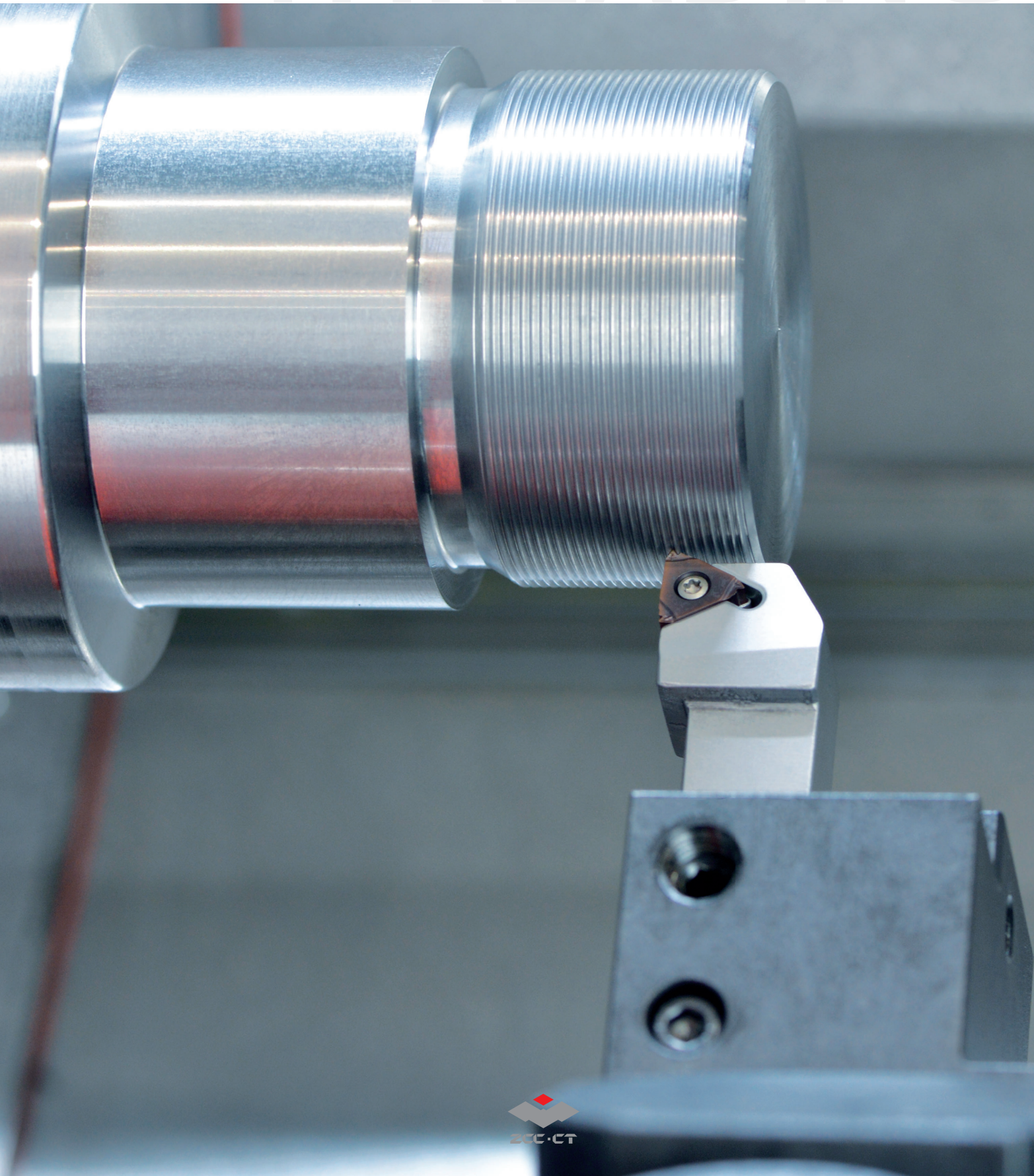

**A**

Turning

**B**

Milling

**C**

Drilling

**D**Technical  
Information**E**

Index

## Threading

System overview	A460-A463
Grade overview	A464
Application fields of grades	A465
System code - inserts	A466
Inserts	A467-A491
System code - threading tool holders	A492
Threading tool holders	A493-A499
Recommended cutting data	A500
Trouble shooting	A504
Technical Information	A511-A512
Special tools	A513



**A**  
Turning











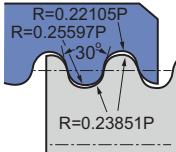

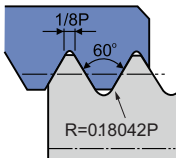

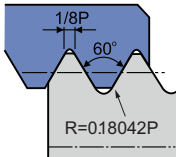

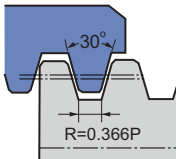
**B**  
Milling

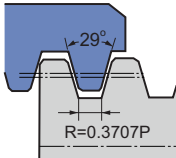
**C**  
Drilling

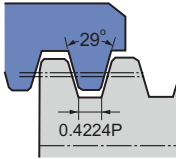
**D**  
Technical Information

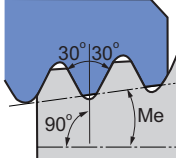
**E**  
Index

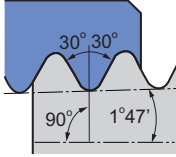
Thread types	Profile	Sectional drawing	Insert	Internal thread pitch mm (TPI)	External thread pitch mm (TPI)	Page
ISO metric coarse thread 60° full profile	GM			0,5-6,0	0,5-6,0	A467
60° partial profile	60°			0,5-5,0 (5-48)	0,5-5,0 (5-48)	A469
55° partial profile	55°			0,5-5,0 (5-48)	0,5-5,0 (5-48)	A470
Whitworth	W			(8-16)	(8-16)	A471
UN unified conventional thread 60° full profile	UN			(8-20)	(8-20)	A472
BSPT Whitworth taper pipe thread	BSPT			(11-28)	11-28	A473
NPT American taper pipe thread	NPT			(8-27)	(8-27)	A474
NPTF dryseal American taper pipe thread 60°	NPTF			(8-27)	(8-27)	A475

Thread types	Profile	Sectional drawing	Insert	Internal thread pitch mm (TPI)	External thread pitch mm (TPI)	Page
R knuckle thread 30°	R			(6-10)	(6-10)	A476
MJ thread for aerospace	MJ			---	1,5-2,0	A477
UNJ unified screw thread	UNJ			---	(8-32)	A478
TR metrical ISO trapezoidal thread 30°	Tr			1,5-3,0	1,5-3,0	A479
ACME American national thread 29°	AC			(8-16)	(8-16)	A480
STUB-ACME thread	STAC			(8-16)	(8-16)	A481
API 60° thread	AP			4-5	(4-5)	A482
API round thread	RD			8-10	(8-10)	A483

<b>A</b>	Turning
<b>B</b>	Milling
<b>C</b>	Drilling
<b>D</b>	Technical Information
<b>E</b>	Index

**A**  
Turning

**B**  
Milling

**C**  
Drilling

**D**  
Technical Information

**E**  
Index

Thread types	Profile	Sectional drawing	Insert	Internal thread pitch mm (TPI)	External thread pitch mm (TPI)	Page
API American buttress thread	BUT			(5)	(5)	A484
ISO metric coarse thread 60° full profile (thin type)	GM			0,5-3,0	0,5-3,0	A485
60° partial profile (thin type)	60°			0,5-3,0 (8-48)	0,5-3,0 (8-48)	A486
55° partial profile (thin type)	55°			0,5-3,0 (8-48)	0,5-3,0 (8-48)	A487
Whitworth (thin type)	W			(8-16)	(8-16)	A488
UN unified conventional thread 60° full profile (thin type)	UN			(8-24)	(8-20)	A489
BSPT Whitworth taper pipe thread (thin type)	BSPT			(11-28)	(11-28)	A490
NPT American taper pipe thread (thin type)	NPT			(8-27)	(8-27)	A491

Type	Tool holder	Dimensions [mm]	Page
External thread holder		16×16×100 20×20×125 25×25×150 32×25×170 32×32×170 40×40×250	A493
Internal thread holder		16×125×12 16×150×16 16×150×20 20×150×25 20×180×25 25×150×32 32×200×40 32×250×40 40×300×50 50×350×63	A495
External thread holder (Thin Type)		16×16×100 32×25×170 20×20×125 32×32×170 25×25×150	A497
Internal thread holder (Thin Type)		16×150×20 32×200×40 20×180×25 32×250×40 25×150×32	A498

**A**

Turning

**B**

Milling

**C**

Drilling

**D**

Technical  
Information

**E**

Index

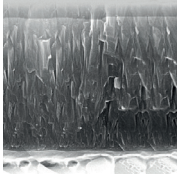
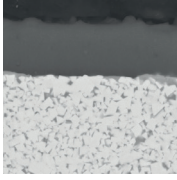

## Threading

Grade	ISO	Micro structure	Grade description
<b>YBG201</b>	P10 - P30 M10 - M30		PVD coated P10–P30/M10–M30 carbide substrate for finishing to medium application of steel and stainless steel. Good wear resistance in a wide application field.
<b>YBG205</b>	P10 - P30 M20 - M40 S15-S25		PVD multilayer coated P10–P30/M20–M40/S15–S25 carbide substrate for finishing to medium machining of stainless steel, super alloys and steel (milling). Excellent wear resistance and thermal stability in a wide range of applications.

**A**

Turning

**B**

Milling

**C**

Drilling

**D**

Technical  
Information

**E**

Index

Application fields of grades – threading

	ISO	HC <sup>1</sup> (CVD)	HC <sup>1</sup> (PVD)	HT	HC <sup>2</sup>	Ceramic	HW	CBN	PCD
<b>P</b>	P01								
	P10		YBG205						
	P20								
	P30								
	P40								
<b>M</b>	M01								
	M10		YBG205						
	M20								
	M30								
	M40								
<b>K</b>	K01								
	K10								
	K20								
	K30								
<b>N</b>	N01								
	N10								
	N20								
	N30								
<b>S</b>	S01								
	S10		YBG205						
	S20								
	S30								
<b>H</b>	H01								
	H10								
	H20								
	H30								

<b>P</b>	Steel
<b>M</b>	Stainless steel
<b>K</b>	Cast iron

<b>N</b>	Non-ferrous metals
<b>S</b>	Heat-resistant alloys
<b>H</b>	Hardened materials

HC <sup>1</sup>	Coated carbide
HT	Uncoated cermet
HC <sup>2</sup>	Coated cermet
HW	Uncoated carbide

**A**

Turning

**B**

Milling

**C**

Drilling

**D**

Technical Information

**E**

Index

## R T 22. 01 W – 3.50 GM (P) (B)

1 2 3 4 5 6 7 8 9

Type	
Code	Description
R	Right
L	Left

1

Insert shape	
T 	Z Special

2

Insert size [mm]	
Code	I.C
11	6,35
16	9,252
22	12,70

3

Teeth per cutting edge	
Code	Description
01	1
02	2

4

Application	
Code	Description
W	External thread
N	Internal thread

5

Pitch		
Code	Pitch range (part profile)	
A	0,5 – 1,5 mm	48 – 16 (TPI)
AG	0,5 – 3,0 mm	48 – 8 (TPI)
G	1,75 – 3,0 mm	14 – 8 (TPI)
N	3,5 – 5,0 mm	7 – 5 (TPI)
Pitch range [mm] (full profile)		
	0,50 0,75 1,00 1,25 1,50	
	1,75 2,00 2,50 3,00 3,50	
	4,00 4,50 5,00 5,50 6,00	
Pitch range (TPI) (full profile)		
	4 5 6 8	
	10 11 11,5 12	
	14 16 18 19	
	20 24 27 28	

6

Thread profile	
Code	Description
GM	ISO metric coarse thread 60°
60	Partial profile 60°
55	Partial profile 55°
W	Whitworth
UN	Unified conventional thread
BSPT	Whitworth taper pipe thread
NPT	American taper pipe thread
NPTF	Dryseal American taper pipe thread
R	Knuckle thread 30°
MJ	Thread for aerospace
UNJ	Unified screw thread
TR	Metrical ISO trapezoidal thread
AC	American national thread
STAC	STUB-ACME thread
AP	API 60° thread
RD	API round thread
BUT	American buttress thread

7

Chip breaker
--------------

8

Insert thickness [mm]	
Code	Description
B	Thin type

9

R/LT**N/W	I.C	S	d
<b>11</b>	6.35	3.18	2.8
<b>16</b>	9.525	3.97	4.4
<b>22</b>	12.7	5.56	5.5

**Threading inserts**

ISO metric coarse thread 60° full profile

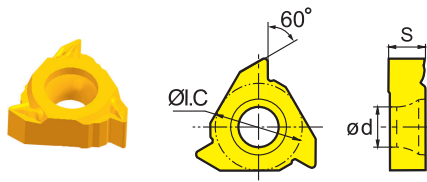

External right hand  
Internal left hand

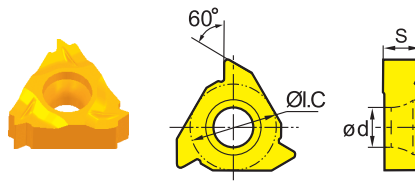

Internal right hand  
External left hand

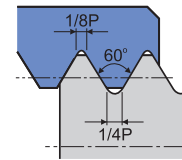

ISO 965-1980 DIN 13  
GB-T 197-2003 Tolerance: 6g-6H

ISO	Pitch (mm)	External	HC <sup>1</sup> (PVD)				Internal	HC <sup>1</sup> (PVD)			
			YBG201	YBG205				YBG201	YBG205		
11	0.50	-					RT11.01N-0.50GM	○			
11		-					LT11.01N-0.50GM	○			
11	0.75	-					RT11.01N-0.75GM	●			
11		-					LT11.01N-0.75GM	○			
11	1.00	-					RT11.01N-1.00GM	○ ●			
11		-					LT11.01N-1.00GM	●			
11	1.25	-					RT11.01N-1.25GM	●			
11		-					LT11.01N-1.25GM	●			
11	1.50	-					RT11.01N-1.50GM	○ ●			
11		-					LT11.01N-1.50GM	●			
11	1.75	-					RT11.01N-1.75GM	○			
11		-					LT11.01N-1.75GM	●			
11	2.00	-					RT11.01N-2.00GM	○ ●			
11		-					LT11.01N-2.00GM	●			
16	0.50	-					RT16.01N-0.50GM	○			
16		-					LT16.01N-0.50GM	○			
16	0.75	-					RT16.01N-0.75GM	○			
16		-					LT16.01N-0.75GM	○			
16	1.00	RT16.01W-1.00GM	○ ●				RT16.01N-1.00GM	○			
16		LT16.01W-1.00GM	●				LT16.01N-1.00GM	●			
16	1.25	RT16.01W-1.25GM	○ ●				RT16.01N-1.25GM	○			
16		LT16.01W-1.25GM	●				LT16.01N-1.25GM	●			
16	1.50	RT16.01W-1.50GM	○ ●				RT16.01N-1.50GM	●			
16		LT16.01W-1.50GM	●				LT16.01N-1.50GM	●			
16	1.75	RT16.01W-1.75GM	●				RT16.01N-1.75GM	○			
16		LT16.01W-1.75GM	●				LT16.01N-1.75GM	●			
16	2.00	RT16.01W-2.00GM	○ ●				RT16.01N-2.00GM	○ ●			

● Ex stock ○ On demand

HC<sup>1</sup> Coated carbide

A

Turning

B

Milling

C

Drilling

D

Technical Information

E

Index

R/LT**N/W	I.C	S	d
<b>11</b>	6.35	3.18	2.8
<b>16</b>	9.525	3.97	4.4
<b>22</b>	12.7	5.56	5.5

## Threading inserts

### ISO metric coarse thread 60° full profile

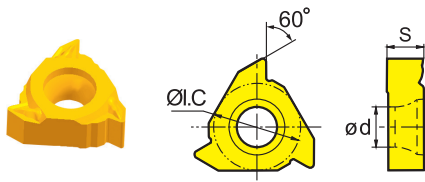

External right hand  
Internal left hand

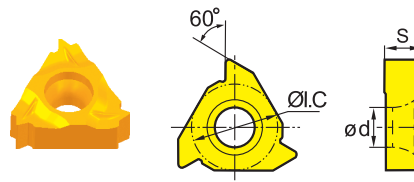

Internal right hand  
External left hand

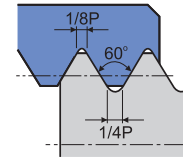



ISO 965-1980 DIN 13  
GB-T 197-2003 Tolerance: 6g-6H

ISO	Pitch (mm)	External	HC <sup>1</sup> (PVD)					Internal	HC <sup>1</sup> (PVD)					
			YBG201	YBG205					YBG201	YBG205				
16	2.00	LT16.01W-2.00GM	●					LT16.01N-2.00GM	●					
16	2.50	RT16.01W-2.50GM	○	●				RT16.01N-2.50GM	○	●				
16		LT16.01W-2.50GM	●					LT16.01N-2.50GM	●					
16	3.00	RT16.01W-3.00GM	○	●				RT16.01N-3.00GM	○	●				
16		LT16.01W-3.00GM	●					LT16.01N-3.00GM	●					
22	3.50	RT22.01W-3.50GM	○					RT22.01N-3.50GM	○	●				
22		LT22.01W-3.50GM	●					LT22.01N-3.50GM	●					
22	4.00	RT22.01W-4.00GM	○	●				RT22.01N-4.00GM	●					
22		LT22.01W-4.00GM	●					LT22.01N-4.00GM	●					
22	4.50	RT22.01W-4.50GM	○					RT22.01N-4.50GM	○	●				
22		LT22.01W-4.50GM	○					LT22.01N-4.50GM	●					
22	5.00	RT22.01W-5.00GM	○					RT22.01N-5.00GM	○					
22		LT22.01W-5.00GM	●					LT22.01N-5.00GM	●					
22	5.50	RT22.01W-5.50GM	○					RT22.01N-5.50GM	○					
22		LT22.01W-5.50GM	○					LT22.01N-5.50GM	●					
22	6.00	RT22.01W-6.00GM	○	●				RT22.01N-6.00GM	○	●				
22		LT22.01W-6.00GM	●					LT22.01N-6.00GM	●					

● Ex stock ○ On demand

HC<sup>1</sup> Coated carbide

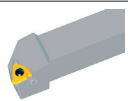
### Tool holders

SWR/L	SNR/L
	
A493-A494	A495-A496

System code > A466

Grade selection > A465

Technical info > A501

Cutting data > A500

Threading inserts

R/LT**N/W	I.C	S	d
<b>16</b>	9.525	3.97	4.4
<b>22</b>	12.7	5.56	5.5

60° partial profile

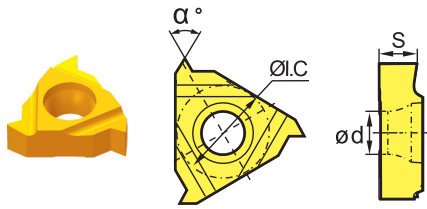

External right hand  
Internal left hand

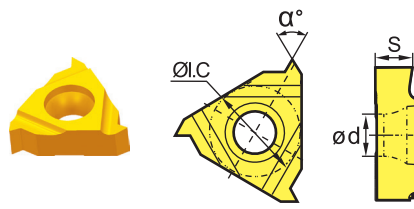

Internal right hand  
External left hand

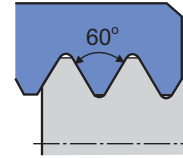



ISO	Pitch (mm)	External	HC <sup>1</sup> (PVD)					Internal	HC <sup>1</sup> (PVD)					
			YBG201	YBG205					YBG201	YBG205				
16	0.50 - 1.50	RT16.01W-A60	○	●				RT16.01N-A60	○					
16		LT16.01W-A60	●					LT16.01N-A60	●					
16	0.50 - 3.00	RT16.01W-AG60	○	●				RT16.01N-AG60	○					
16		LT16.01W-AG60	●					LT16.01N-AG60	●	●				
16	1.75 - 3.00	RT16.01W-G60	○					RT16.01N-G60	○					
16		LT16.01W-G60	●					LT16.01N-G60	○					
16		LT16.01W-G60P	●					LT16.01N-G60P	○					
16		RT16.01W-G60P*	○	○				RT16.01N-G60P*	○					
22	3.50 - 5.00	LT22.01W-N60P	○					-						
22		RT22.01W-N60P*	●					RT22.01N-N60P*	●					
22		LT22.01W-N60P*						LT22.01N-N60P*	○					

● Ex stock ○ On demand  
P\*: Inserts with chip-breakers

HC<sup>1</sup> Coated carbide

Tool holders

SWR/L	SNR/L
	
A493-A494	A495-A496

R/LT**N/W	I.C	S	d
<b>16</b>	9.525	3.97	4.4
<b>22</b>	12.7	5.56	5.5

## Threading inserts

### 55° partial profile

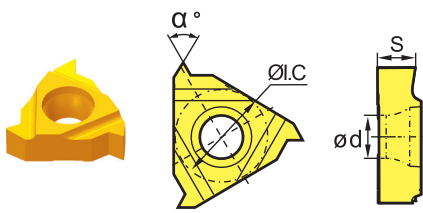

External right hand  
Internal left hand

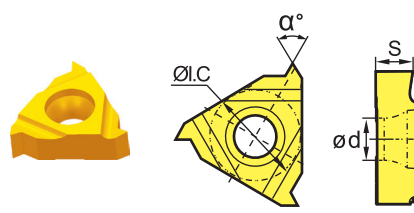

Internal right hand  
External left hand

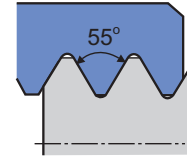



ISO	Pitch (T.Pi)	External	HC <sup>1</sup> (PVD)					Internal	HC <sup>1</sup> (PVD)					
			YBG201	YBG205					YBG201	YBG205				
16	48 - 16	RT16.01W-A55	○					RT16.01N-A55	○					
16		LT16.01W-A55	●					LT16.01N-A55	○					
16	48 - 8	RT16.01W-AG55	●					RT16.01N-AG55	○ ●					
16		LT16.01W-AG55	○					LT16.01N-AG55	●					
16	14 - 8	RT16.01W-G55	○					RT16.01N-G55	○					
16		LT16.01W-G55	●					LT16.01N-G55	○					
16		LT16.01W-G55P	●					LT16.01N-G55P	●					
16		RT16.01W-G55P*	○					RT16.01N-G55P*	○					
22	7 - 5	RT22.01W-N55P	○					RT22.01N-N55P	○					
22		-						LT22.01N-N55	○					

● Ex stock ○ On demand  
P\*: Inserts with chip-breakers

HC<sup>1</sup> Coated carbide

### Tool holders

SWR/L	SNR/L
	
A493-A494	A495-A496

System code > A466

Grade selection > A465

Technical info > A501

Cutting data > A500

Threading inserts

R/LT**N/W	I.C	S	d
<b>16</b>	9.525	3.97	4.4

Whitworth

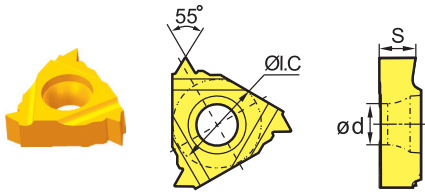

External right hand  
Internal left hand

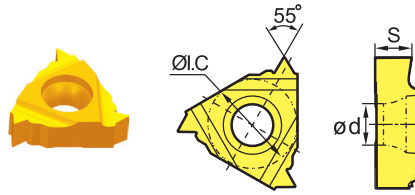

Internal right hand  
External left hand

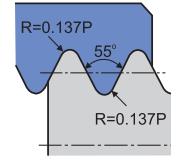

ISO 228-1:1982 DIN 259  
B.S.84: 1956 Tolerance: Medium Class 1

ISO	Pitch (T.P.i)	External	HC <sup>1</sup> (PVD)					Internal	HC <sup>1</sup> (PVD)					
			YBG201	YBG205					YBG201	YBG205				
16	8.00	RT16.01W-8W	○					RT16.01N-8W	○					
16		LT16.01W-8W	●					LT16.01N-8W	●					
16	9.00	-						RT16.01N-9W	○					
16		LT16.01W-9W	○					LT16.01N-9W	○					
16	10.00	RT16.01W-10W	○					RT16.01N-10W	○					
16		LT16.01W-10W	○					LT16.01N-10W	○					
16	11.00	RT16.01W-11W	○ ●					RT16.01N-11W	○ ●					
16		LT16.01W-11W	●					LT16.01N-11W	○					
16	12.00	RT16.01W-12W	○					RT16.01N-12W	○					
16		LT16.01W-12W	○					LT16.01N-12W	○					
16	14.00	RT16.01W-14W	●					RT16.01N-14W	○ ●					
16		LT16.01W-14W	○					LT16.01N-14W	○					
16	16.00	RT16.01W-16W	○ ●					RT16.01N-16W	○ ●					
16		LT16.01W-16W	○					LT16.01N-16W	○					

● Ex stock ○ On demand

HC<sup>1</sup> Coated carbide

Tool holders

SWR/L	SNR/L
A493-A494	A495-A496



R/LT**N/W	I.C	S	d
16	9.525	3.97	4.4

## Threading inserts

UN unified conventional thread 60° full profile

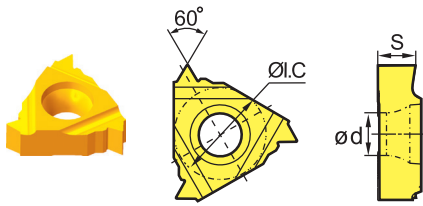

External right hand  
Internal left hand

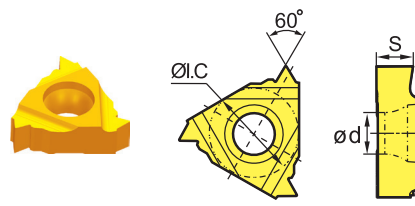

Internal right hand  
External left hand

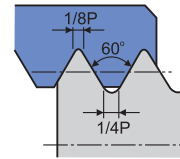



AS/E B1.1-1989  
Tolerance: 2A-2B

ISO	Pitch (T.Pi)	External	HC <sup>1</sup> (PVD)				Internal	HC <sup>1</sup> (PVD)			
			YBG201	YBG205				YBG201	YBG205		
16	8.00	RT16.01W-8UN	○				RT16.01N-8UN	○			
16		LT16.01W-8UN	○				LT16.01N-8UN	○			
16	10.00	RT16.01W-10UN	○				RT16.01N-10UN	○			
16		LT16.01W-10UN	○				LT16.01N-10UN	○			
16	12.00	RT16.01W-12UN	○				RT16.01N-12UN	○			
16		LT16.01W-12UN	○				LT16.01N-12UN	○			
16	14.00	RT16.01W-14UN	○				RT16.01N-14UN	○			
16		LT16.01W-14UN	○				LT16.01N-14UN	○			
16	16.00	RT16.01W-16UN	○				RT16.01N-16UN	○			
16		LT16.01W-16UN	○				LT16.01N-16UN	○			
16	18.00	RT16.01W-18UN	○				RT16.01N-18UN	○			
16		LT16.01W-18UN	○				LT16.01N-18UN	○			
16	20.00	RT16.01W-20UN	○				RT16.01N-20UN	○			
16		LT16.01W-20UN	○				LT16.01N-20UN	○			
16	24.00	-					RT16.01N-24UN	○			
16		-					LT16.01N-24UN	○			

● Ex stock ○ On demand

HC<sup>1</sup> Coated carbide

### Tool holders

SWR/L	SNR/L
	
A493-A494	A495-A496

System code > A466

Grade selection > A465

Technical info > A501

Cutting data > A500

A

Turning

B

Milling

C

Drilling

D

Technical Information

E

Index

Threading inserts

R/LT**N/W	I.C	S	d
<b>16</b>	9.525	3.97	4.4

BSPT Whitworth taper pipe thread

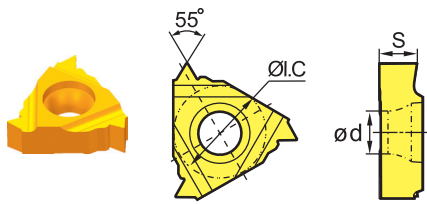

External right hand  
Internal left hand

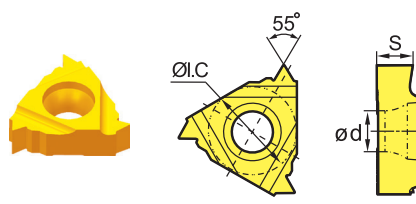

Internal right hand  
External left hand

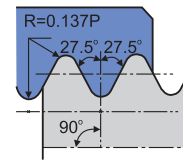



ISO 7-1: 1984 B.S.21:1985  
Standard BSPT

ISO	Pitch (T.P.i)	External	HC <sup>1</sup> (PVD)				Internal	HC <sup>1</sup> (PVD)			
			YBG201	YBG205				YBG201	YBG205		
16	11.00	RT16.01W-11BSPT	○				RT16.01N-11BSPT	○			
16		LT16.01W-11BSPT	●				LT16.01N-11BSPT	○			
16	14.00	RT16.01W-14BSPT	○				RT16.01N-14BSPT	○			
16		LT16.01W-14BSPT	○				LT16.01N-14BSPT	○			
16	19.00	RT16.01W-19BSPT	○				RT16.01N-19BSPT	○			
16		LT16.01W-19BSPT	○				LT16.01N-19BSPT	○			
16	28.00	RT16.01W-28BSPT	○				RT16.01N-28BSPT	○			
16		LT16.01W-28BSPT	○				LT16.01N-28BSPT	○			

● Ex stock ○ On demand

HC<sup>1</sup> Coated carbide

Tool holders

SWR/L	SNR/L
	
A493-A494	A495-A496

A

## Threading inserts

R/LT**N/W	I.C	S	d
16	9.525	3.97	4.4

Turning

### NPT American taper pipe thread

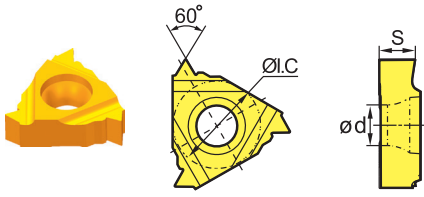

External right hand  
Internal left hand

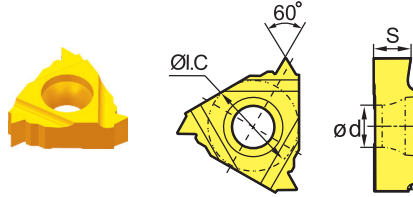

Internal right hand  
External left hand

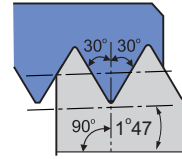

ASME B1.20.1-1983  
Standard NPT

B

Milling

ISO	Pitch (T.P.i)	External	HC <sup>1</sup> (PVD)				Internal	HC <sup>1</sup> (PVD)			
			YBG201	YBG205				YBG201	YBG205		
16	8.00	RT16.01W-8NPT	○				RT16.01N-8NPT	○			
16		LT16.01W-8NPT	○				LT16.01N-8NPT	○			
16	11.50	RT16.01W-11.5NPT	○				RT16.01N-11.5NPT	○			
16		LT16.01W-11.5NPT	○				LT16.01N-11.5NPT	○			
16	14.00	RT16.01W-14NPT	○	○			RT16.01N-14NPT	○			
16		LT16.01W-14NPT	○				LT16.01N-14NPT	○			
16	18.00	RT16.01W-18NPT	○				RT16.01N-18NPT	○			
16		LT16.01W-18NPT	○				LT16.01N-18NPT	○			
16	27.00	RT16.01W-27NPT	○				RT16.01N-27NPT	○			
16		LT16.01W-27NPT	○				LT16.01N-27NPT	○			

● Ex stock ○ On demand

HC<sup>1</sup> Coated carbide



C

Drilling

D

Technical Information

### Tool holders

SWR/L	SNR/L
	
A493-A494	A495-A496

E

Index

System code > A466

Grade selection > A465

Technical info > A501

Cutting data > A500

Threading inserts

R/LT**N/W	I.C	S	d
<b>16</b>	9.525	3.97	4.4

NPTF dryseal American taper pipe thread 60°

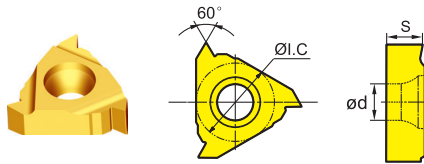

External right hand  
Internal left hand

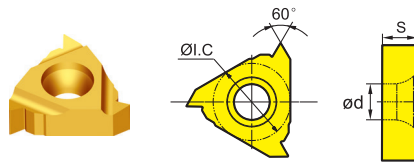

Internal right hand  
External left hand

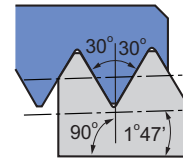



ASME B1.20.1-1983  
Tolerance: 2

ISO	Pitch (T.P.i)	External	HC <sup>1</sup> (PVD)				Internal	HC <sup>1</sup> (PVD)			
			YBG201	YBG205				YBG201	YBG205		
16	8.00	-					RT16.01N-8NPTF	○			
16	11.50	RT16.01W-11.5NPTF	○				RT16.01N-11.5NPTF	○			
16	14.00	RT16.01W-14NPTF	○				RT16.01N-14NPTF	○			
16	18.00	RT16.01W-18NPTF	○				RT16.01N-18NPTF	○			
16	27.00	-					RT16.01N-27NPTF	○			

● Ex stock ○ On demand

HC<sup>1</sup> Coated carbide

Tool holders

SWR/L	SNR/L
	
A493	A495

A

Turning

B

Milling

C

Drilling

D

Technical Information

E

Index

**A**

## Threading inserts

R/LT**N/W	I.C	S	d
16	9.525	3.97	4.4

Turning

### R knuckle thread 30°

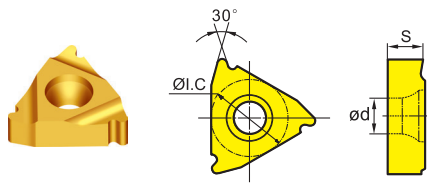

External right hand  
Internal left hand

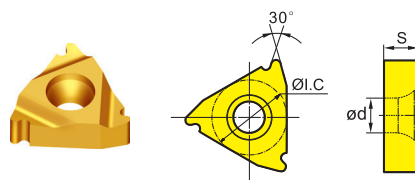

Internal right hand  
External left hand

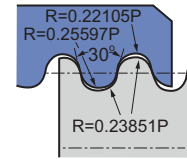

DIN 405  
Tolerance: 7

**B**

Milling

ISO	Pitch (T.P.i)	External	HC <sup>1</sup> (PVD)				Internal	HC <sup>1</sup> (PVD)			
			YBG201	YBG205				YBG201	YBG205		
16	6.00	RT16.01W-6R	○				RT16.01N-6R	○	○		
16	8.00	RT16.01W-8R	○				RT16.01N-8R	○	○		
16	10.00	RT16.01W-10R	○				RT16.01N-10R	○	○		

● Ex stock ○ On demand

HC<sup>1</sup> Coated carbide

**C**

Drilling

### Tool holders

SWR/L	SNR/L
A493	A495

**D**

Technical Information

**E**

Index

System code > A466

Grade selection > A465

Technical info > A501

Cutting data > A500

**Threading inserts**

R/LT**N/W	I.C	S	d
<b>16</b>	9.525	3.97	4.4

**MJ thread for aerospace**

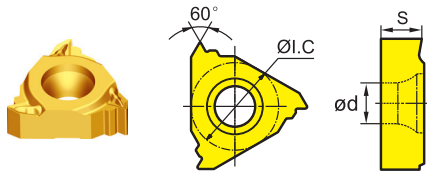

External right hand  
Internal left hand

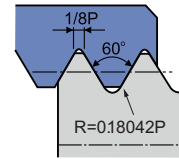

ISO 5855-1999  
Tolerance: 4

ISO	Pitch (mm)	External	HC <sup>1</sup> (PVD)					Internal	HC <sup>1</sup> (PVD)					
			YBG201	YBG205					YBG201	YBG205				
16	1.50	<b>RT16.01W-1.50MJ</b>	○					-						
16	2.00	<b>RT16.01W-2.00MJ</b>	○					-						

● Ex stock ○ On demand

HC<sup>1</sup> Coated carbide

**Tool holders**

SWR/L

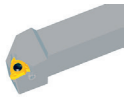

A493

**A**

Turning

**B**

Milling

**C**

Drilling

**D**

Technical Information

**E**

Index

**A**

## Threading inserts

R/LT**N/W	I.C	S	d
16	9.525	3.97	4.4

Turning

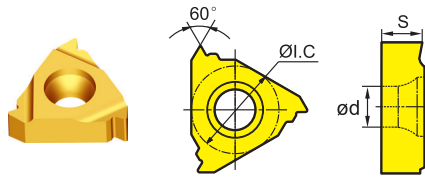

External right hand  
Internal left hand

### UNJ unified screw thread

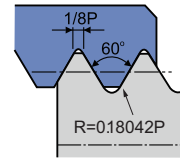

ISO 3161-1999  
Tolerance: 3A

**B**

Milling

ISO	Pitch (T.P.i)	External	HC <sup>1</sup> (PVD)					Internal	HC <sup>1</sup> (PVD)					
			YBG201	YBG205					YBG201	YBG205				
16	10.00	RT16.01W-10UNJ	○					-						
16	12.00	RT16.01W-12UNJ	○					-						
16	14.00	RT16.01W-14UNJ	○					-						
16	18.00	RT16.01W-18UNJ	○					-						
16	20.00	RT16.01W-20UNJ	○					-						
16	24.00	RT16.01W-24UNJ	○					-						
16	28.00	RT16.01W-28UNJ	○					-						
16	32.00	RT16.01W-32UNJ	○					-						

● Ex stock ○ On demand

HC<sup>1</sup> Coated carbide

**C**

Drilling

### Tool holders

SWR/L



A493

**D**

Technical Information

**E**

Index

System code > A466

Grade selection > A465

Technical info > A501

Cutting data > A500

Threading inserts

R/LT**N/W	I.C	S	d
<b>16</b>	9.525	3.97	4.4

TR metrical ISO trapezoidal thread 30°

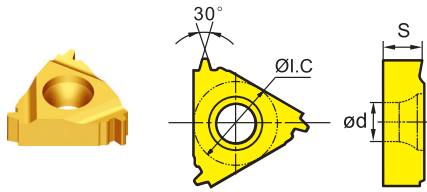

External right hand  
Internal left hand

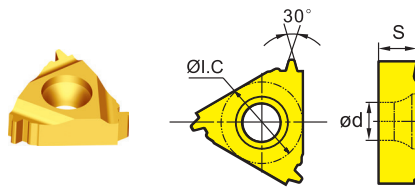

Internal right hand  
External left hand

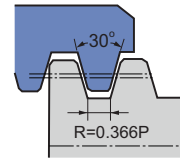



ISO 2901-2904  
Tolerance: 7

ISO	Pitch (mm)	External	HC <sup>1</sup> (PVD)					Internal	HC <sup>1</sup> (PVD)					
			YBG201	YBG205					YBG201	YBG205				
16	1.50	RT16.01W-1.50TR	○					●						
16	2.00	RT16.01W-2.00TR	○ ○					○ ○						
16	3.00	RT16.01W-3.00TR	○ ○					○ ●						

● Ex stock ○ On demand

HC<sup>1</sup> Coated carbide

Tool holders

SWR/L	SNR/L
	
A493	A495

A

Turning

B

Milling

C

Drilling

D

Technical Information

E

Index



R/LT**N/W	I.C	S	d
16	9.525	3.97	4.4

## Threading inserts

ACME American national thread 29°

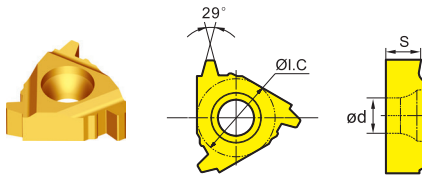

External right hand  
Internal left hand

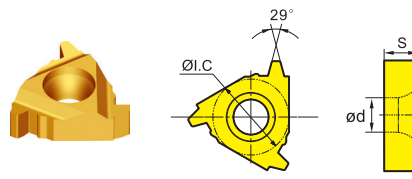

Internal right hand  
External left hand

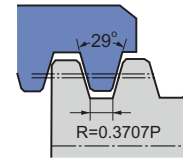



ANSI B1.5-1988  
Tolerance: 2G

ISO	Pitch (T.P.i)	External	HC <sup>1</sup> (PVD)				Internal	HC <sup>1</sup> (PVD)			
			YBG201	YBG205				YBG201	YBG205		
16	8.00	RT16.01W-8AC	○				RT16.01N-8AC	○			
16	10.00	RT16.01W-10AC	○				RT16.01N-10AC	○			
16	12.00	RT16.01W-12AC	○				RT16.01N-12AC	○			
16	14.00	RT16.01W-14AC	○				RT16.01N-14AC	○			
16	16.00	RT16.01W-16AC	○				RT16.01N-16AC	○			

● Ex stock ○ On demand

HC<sup>1</sup> Coated carbide

### Tool holders

SWR/L	SNR/L
	
A493	A495

A

Turning

B

Milling

C

Drilling

D

Technical Information

E

Index

System code > A466

Grade selection > A465

Technical info > A501

Cutting data > A500

Threading inserts

R/LT**N/W	I.C	S	d
<b>16</b>	9.525	3.97	4.4

STUB-ACME thread

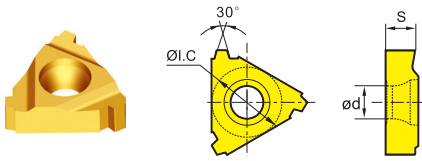

External right hand  
Internal left hand

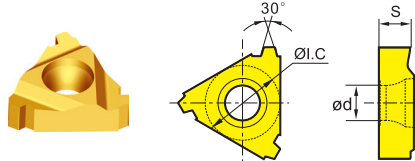

Internal right hand  
External left hand

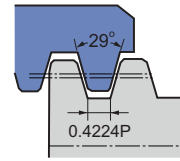



ANSI B1.8-1988  
Tolerance: API Standard

ISO	Pitch (T.P.i)	External	HC <sup>1</sup> (PVD)				Internal	HC <sup>1</sup> (PVD)			
			YBG201	YBG205				YBG201	YBG205		
16	8.00	RT16.01W-8STAC	○				RT16.01N-8STAC	○			
16	10.00	RT16.01W-10STAC	○				RT16.01N-10STAC	○			
16	12.00	RT16.01W-12STAC	○				RT16.01N-12STAC	○			
16	14.00	RT16.01W-14STAC	○				RT16.01N-14STAC	○			
16	16.00	RT16.01W-16STAC	○				RT16.01N-16STAC	○			

● Ex stock ○ On demand

HC<sup>1</sup> Coated carbide

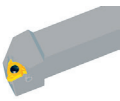
Tool holders

SWR/L	SNR/L
	
A493	A495

A

Turning

B

Milling

C

Drilling

D

Technical Information

E

Index

System code > A466

Grade selection > A465

Technical info > A501

Cutting data > A500

**A**

## Threading inserts

R/LT**N/W	I.C	S	d
<b>22</b>	12.7	5.56	5.5

Turning

### API 60° thread

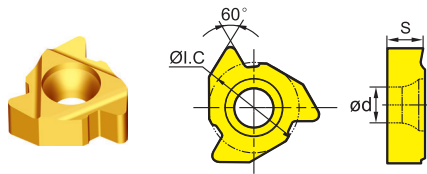

External right hand  
Internal left hand

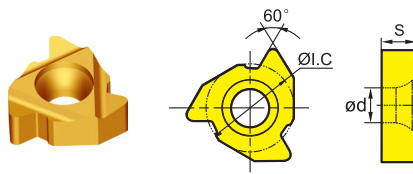

Internal right hand  
External left hand

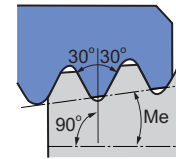

Me = taper, 2i.p.f-4°46', 3i.p.f-7°01'  
API SPEC7:1990 Tolerance: API Standard

**B**

Milling



ISO	Pitch (T.P.i)	External	HC <sup>1</sup> (PVD)				Internal	HC <sup>1</sup> (PVD)			
			YBG201	YBG205				YBG201	YBG205		
22	4.00	RT22.01W-4AP382	○				RT22.01N-4AP382	○			
22		RT22.01W-4AP383	○				RT22.01N-4AP383	○			
22		RT22.01W-4AP502	○				RT22.01N-4AP502	○			
22		RT22.01W-4AP503	○				RT22.01N-4AP503	○			
22	5.00	RT22.01W-5AP403	○				RT22.01N-5AP403	○			

● Ex stock ○ On demand

HC<sup>1</sup> Coated carbide

**C**

Drilling

Tool holders	
SWR/L	SNR/L
	
A493	A495

**D**

Technical Information

**E**

Index

System code > A466

Grade selection > A465

Technical info > A501

Cutting data > A500

Threading inserts

R/LT**N/W	I.C	S	d
<b>16</b>	9.525	3.97	4.4
<b>22</b>	12.7	5.56	5.5

API round thread

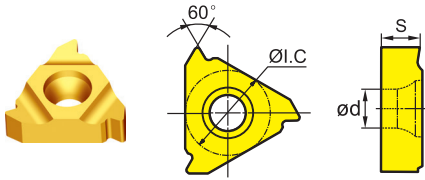

External right hand  
Internal left hand

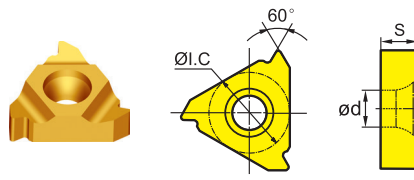

Internal right hand  
External left hand

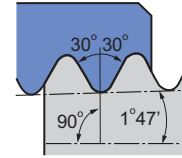



API spec.5B  
Tolerance: API RD

ISO	Pitch (T.P.i)	External	HC <sup>1</sup> (PVD)				Internal	HC <sup>1</sup> (PVD)			
			YBG201	YBG205				YBG201	YBG205		
16	8.00	RT16.01W-8RD	○				RT16.01N-8RD	○			
16	10.00	RT16.01W-10RD	○				RT16.01N-10RD	○			
22	8.00	RT22.01W-8RD	○				RT22.01N-8RD	○			
22	10.00	RT22.01W-10RD	○				RT22.01N-10RD	○			

● Ex stock ○ On demand

HC<sup>1</sup> Coated carbide

Tool holders

SWR/L	SNR/L
	
A493	A495

**A**

## Threading inserts

R/LT**N/W	I.C	S	d
<b>22</b>	12.7	5.56	5.5

Turning

### API American buttress thread

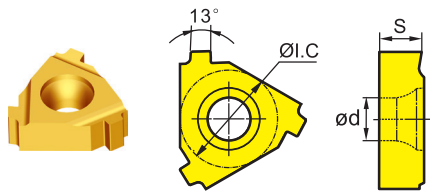

External right hand  
Internal left hand

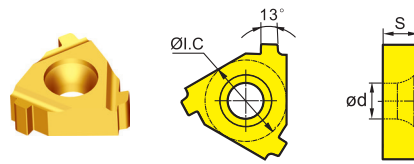

Internal right hand  
External left hand

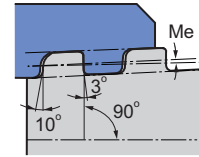

Me=taper 3/4i.p.f-1°47'-1°47' for Ø 4 1/2-13 3/8"  
1 i.p.f--2°23' for Ø16" SEPC.5B.1979 Tol.: API Std.

**B**

Milling

ISO	Pitch (T.P.i)	External	HC <sup>1</sup> (PVD)				Internal	HC <sup>1</sup> (PVD)			
			YBG201	YBG205				YBG201	YBG205		
22	5.00	RT22.01W-5BUT	○				RT22.01N-5BUT	○			



● Ex stock ○ On demand

HC<sup>1</sup> Coated carbide

**C**

Drilling

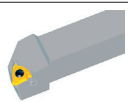
### Tool holders

SWR/L	SNR/L
	
A493	A495

**D**

Technical Information

**E**

Index

System code > A466

Grade selection > A465

Technical info > A501

Cutting data > A500

Threading inserts (thin type)

R/LT**N/W	I.C	S	d
<b>16</b>	9.525	3.52	4

ISO metric coarse thread 60° full profile (thin type)

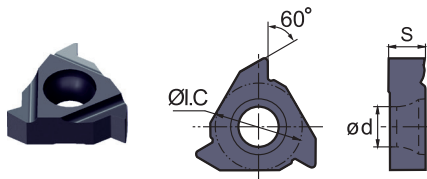

External right hand  
Internal left hand

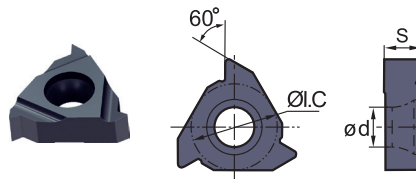

Internal right hand  
External left hand

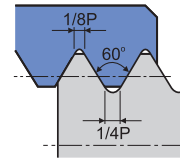



ISO 965-1980 DIN 13  
GB-T 197-2003 Tolerance: 6g/6H

ISO	Pitch (mm)	External	HC <sup>1</sup> (PVD)					Internal	HC <sup>1</sup> (PVD)					
			YBG202	YBG205					YBG202	YBG205				
16	0.50	RT16.01W-0.50GMB	○	○				RT16.01N-0.50GMB	○	○				
16	0.75	RT16.01W-0.75GMB	○	○				RT16.01N-0.75GMB	○	○				
16	1.00	RT16.01W-1.00GMB	○	○				RT16.01N-1.00GMB	○	○				
16		-						RT16.01N-1.00GMPB	○					
16	1.25	RT16.01W-1.25GMB	○	○				RT16.01N-1.25GMB	○	○				
16	1.50	RT16.01W-1.50GMB	○	○				RT16.01N-1.50GMB	○					
16		RT16.01W-1.50GMPB*	○	○				-						
16	1.75	RT16.01W-1.75GMB	○	○				RT16.01N-1.75GMB	○	○				
16	2.00	RT16.01W-2.00GMB	○	○				RT16.01N-2.00GMB	○	○				
16		-						RT16.01N-2.00GMPB*	○	○				
16	2.50	RT16.01W-2.50GMB	○	○				RT16.01N-2.50GMB	○	○				
16	3.00	RT16.01W-3.00GMB	○	○				RT16.01N-3.00GMB	○	○				
16		-						RT16.01N-3.00GMPB*	○					

● Ex stock ○ On demand  
PB\*: Inserts with chip-breakers

HC<sup>1</sup> Coated carbide

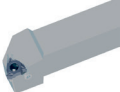
Tool holders

SWR	SNR
	
A497	A498

**A**

## Threading inserts (thin type)

R/LT**N/W	I.C	S	d
16	9.525	3.52	4

Turning

### 60° partial profile (thin type)

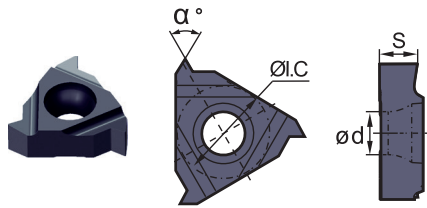

External right hand  
Internal left hand

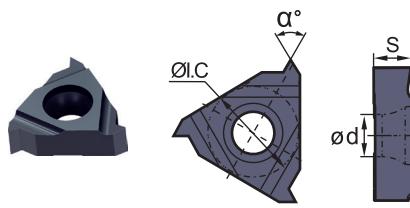

Internal right hand  
External left hand

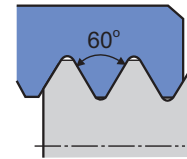

**B**

Milling

ISO	Pitch (mm)	External	HC <sup>1</sup> (PVD)				Internal	HC <sup>1</sup> (PVD)			
			YBG202	YBG205				YBG202	YBG205		
16	0.50 - 1.50	RT16.01W-A60B	○				RT16.01N-A60B	○			
16	0.50 - 3.00	RT16.01W-AG60B	○				RT16.01N-AG60B	○			
16		RT16.01W-AG60PB*	○				-				
16	1.75 - 3.00	RT16.01W-G60B	○				RT16.01N-G60B	○			



● Ex stock ○ On demand  
PB\*: Inserts with chip-breakers

HC<sup>1</sup> Coated carbide

**C**

Drilling

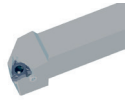
### Tool holders

SWR	SNR
	
A497	A498

**D**

Technical Information

**E**

Index

System code > A466

Grade selection > A465

Technical info > A501

Cutting data > A500

Threading inserts (thin type)

R/LT**N/W	I.C	S	d
<b>16</b>	9.525	3.52	4

55° partial profile (thin type)

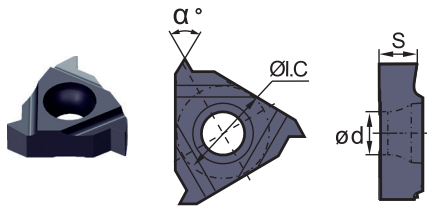

External right hand  
Internal left hand

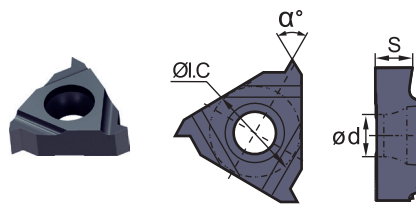

Internal right hand  
External left hand

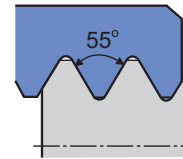



ISO	Pitch (T.P.i)	External	HC <sup>1</sup> (PVD)					Internal	HC <sup>1</sup> (PVD)					
			YBG202	YBG205					YBG202	YBG205				
16	48 - 16	RT16.01W-A55B	○					RT16.01N-A55B	○					
16	48 - 8	RT16.01W-AG55B	○					RT16.01N-AG55B	○					
16		RT16.01W-AG55PB	○	○				-						
16	14 - 8	RT16.01W-G55B	○					RT16.01N-G55B	○					

● Ex stock ○ On demand  
PB\*: Inserts with chip-breakers

HC<sup>1</sup> Coated carbide

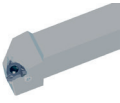
Tool holders

SWR	SNR
	
A497	A498

System code > A466

Grade selection > A465

Technical info > A501

Cutting data > A500

A

Turning

B

Milling

C

Drilling

D

Technical Information

E

Index



**A**

## Threading inserts (thin type)

R/LT**N/W	I.C	S	d
16	9.525	3.52	4

Turning

### Whitworth (thin type)

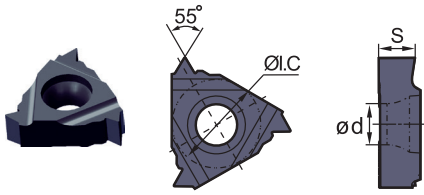

External right hand  
Internal left hand

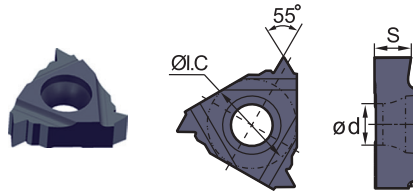

Internal right hand  
External left hand

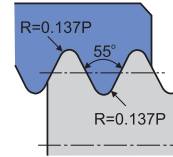

ISO 965-1980 DIN 13  
GB-T 197-2003 Tolerance: Medium Class A

**B**

Milling

ISO	Pitch (T.Pi)	External	HC <sup>1</sup> (PVD)					Internal	HC <sup>1</sup> (PVD)					
			YBG202	YBG205					YBG202	YBG205				
16	8.00	RT16.01W-8WB	○					RT16.01N-8WB	○					
16	9.00	RT16.01W-9WB	○					RT16.01N-9WB	○					
16	10.00	RT16.01W-10WB	○					RT16.01N-10WB	○					
16	11.00	RT16.01W-11WB	○	○				RT16.01N-11WB	○					
16		-						RT16.01N-11WPB	○					
16	12.00	RT16.01W-12WB	○					RT16.01N-12WB	○					
16		-						RT16.01N-12WPB*	○					
16	14.00	RT16.01W-14WB	○					RT16.01N-14WB	○					
16		-						RT16.01N-14WPB*	○					
16	16.00	RT16.01W-16WB	○					RT16.01N-16WB	○	○				

● Ex stock ○ On demand  
PB\*: Inserts with chip-breakers

HC<sup>1</sup> Coated carbide



**C**

Drilling

**D**

Technical Information

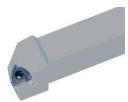
### Tool holders

SWR	SNR
	
A497	A498

**E**

Index

System code > A466

Grade selection > A465

Technical info > A501

Cutting data > A500

**Threading inserts (thin type)**

R/LT**N/W	I.C	S	d
<b>16</b>	9.525	3.52	4

**UN unified conventional thread 60° full profile (thin type)**

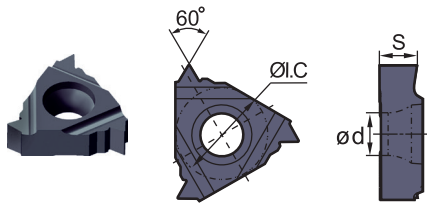

External right hand  
Internal left hand

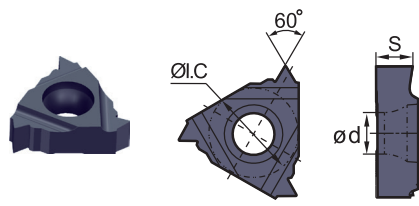

Internal right hand  
External left hand

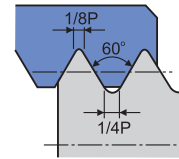



ASME B1.1-1989  
Tolerance: 2A/2B

ISO	Pitch (T.P.i)	External	HC <sup>1</sup> (PVD)				Internal	HC <sup>1</sup> (PVD)			
			YBG202	YBG205				YBG202	YBG205		
16	8.00	<b>RT16.01W-8UNB</b>	○				<b>RT16.01N-8UNB</b>	○			
16	10.00	<b>RT16.01W-10UNB</b>	○				<b>RT16.01N-10UNB</b>	○			
16	12.00	<b>RT16.01W-12UNB</b>	○				<b>RT16.01N-12UNB</b>	○			
16	14.00	<b>RT16.01W-14UNB</b>	○				<b>RT16.01N-14UNB</b>	○			
16	16.00	<b>RT16.01W-16UNB</b>	○				<b>RT16.01N-16UNB</b>	○			
16	18.00	<b>RT16.01W-18UNB</b>	○				<b>RT16.01N-18UNB</b>	○			
16	20.00	<b>RT16.01W-20UNB</b>	○				<b>RT16.01N-20UNB</b>	○			
16	24.00	-					<b>RT16.01N-24UNB</b>	○			

● Ex stock ○ On demand

HC<sup>1</sup> Coated carbide

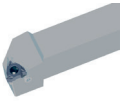
**Tool holders**

SWR	SNR
	
A497	A498

**A**

Turning

**B**

Milling

**C**

Drilling

**D**

Technical Information

**E**

Index

A

## Threading inserts (thin type)

R/LT**N/W	I.C	S	d
16	9.525	3.52	4

Turning

### BSPT Whitworth taper pipe thread (thin type)

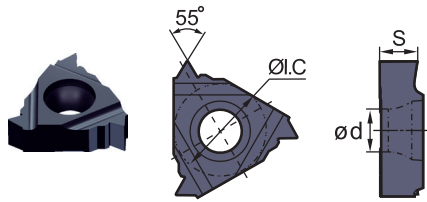

External right hand  
Internal left hand

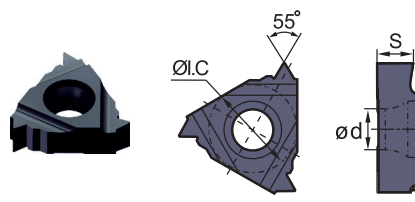

Internal right hand  
External left hand

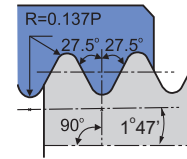

ASME B1.1-1989  
Standard BSPT

B

Milling

ISO	Pitch (T.Pi)	External	HC <sup>1</sup> (PVD)						Internal	HC <sup>1</sup> (PVD)									
			YBG202	YBG205						YBG202	YBG205								
16	11.00	RT16.01W-11BSPTB	○	○															
16	14.00	RT16.01W-14BSPTB	○																
16		RT16.01W-14BSPTPB*	○																
16	19.00	RT16.01W-19BSPTB	○																
16	28.00	RT16.01W-28BSPTB	○																

● Ex stock ○ On demand  
PB\*: Inserts with chip-breakers

HC<sup>1</sup> Coated carbide

C

Drilling

Tool holders	
SWR	SNR
A497	A498

D

Technical Information

E

Index

System code > A466

Grade selection > A465

Technical info > A501

Cutting data > A500

Threading inserts (thin type)

R/LT**N/W	I.C	S	d
<b>16</b>	9.525	3.52	4

NPT American taper pipe thread (thin type)

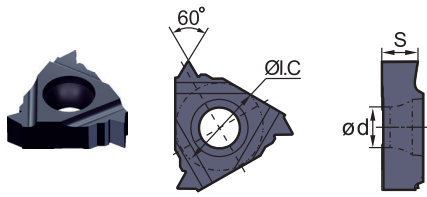

External right hand  
Internal left hand

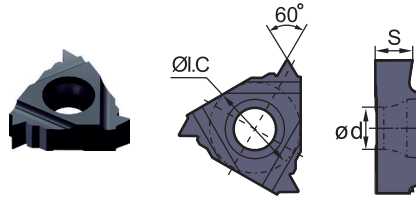

Internal right hand  
External left hand

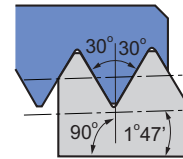



ASME B1.20.1-1983  
Standard NPT

ISO	Pitch (T.P.i)	External	HC <sup>1</sup> (PVD)					Internal	HC <sup>1</sup> (PVD)					
			YBG202	YBG205					YBG202	YBG205				
16	8.00	RT16.01W-8NPTB	○					RT16.01N-8NPTB	○					
16	11.50	RT16.01W-11.5NPTB	○					RT16.01N-11.5NPTB	○					
16		-						RT16.01N-11.5NPTPB*	○					
16	14.00	RT16.01W-14NPTB	○	○				RT16.01N-14NPTB	○					
16		-						RT16.01N-14NPTPB*	○	○				
16	18.00	RT16.01W-18NPTB	○					RT16.01N-18NPTB	○					
16	27.00	RT16.01W-27NPTB	○					RT16.01N-27NPTB	○					

● Ex stock ○ On demand  
PB\*: Inserts with chip-breakers

HC<sup>1</sup> Coated carbide

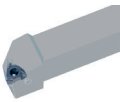
Tool holders



SWR	SNR
	
A497	A498

**S W R 20 20 K 16 (B)**

**1 2 3 4 5 6 7 8**

**A**

Turning

Clamping system		
Code	Description	
S	Screw clamping	
C	Top clamping	

Application	
Code	Description
W	External thread tool holder
N	Internal thread tool holder

**B**

**1**

**2**

Milling

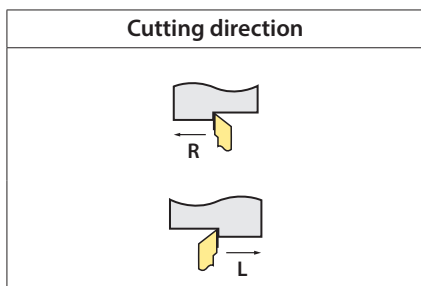

**3**

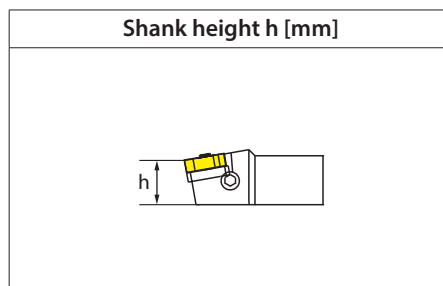

**4**

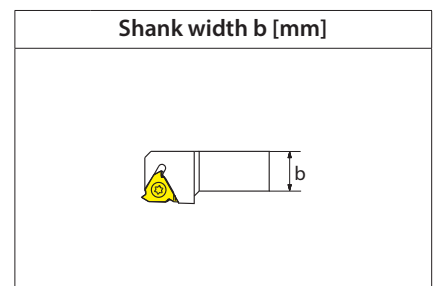

**5**

**C**

Drilling

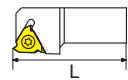
Shank length L [mm]	
	
Code	L
H	100
K	125
M	150
P	170
Q	180
R	200
S	250
T	300

**6**

Insert size [mm]	
Code	Height
11	6,35
16	9,525
22	12,7

**7**

**D**

Technical Information

Holder for thin thread inserts  
(B type)

**8**

**E**

Index

### Threading tool holder (external)

SWR/L

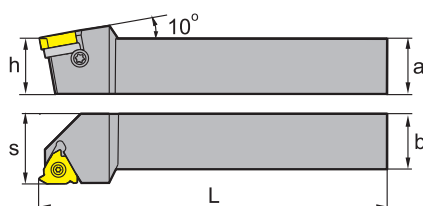
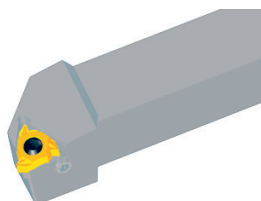

Article	*	Stock	Dimensions [mm]					Inserts
			a	b	L	h	s	
SWR1616H16		●	16	16	100	16	20	RT16.01W-****
SWR2020K16		●	20	20	125	20	25	RT16.01W-****
SWR2525M16		●	25	25	150	25	32	RT16.01W-****
SWR3225P16		●	32	25	170	32	32	RT16.01W-****
SWR3232P16		●	32	32	170	32	40	RT16.01W-****
SWR2525M22		●	25	25	150	25	32	RT22.01W-****
SWR3225P22		●	32	25	170	32	32	RT22.01W-****
SWR3232P22		●	32	32	170	32	40	RT22.01W-****
SWR4040S22		○	40	40	250	40	50	RT22.01W-****

● Ex stock   ○ On demand

\* With internal cooling

Spare parts			
	Insert	RT16.01W-****	RT22.01W-****
	h	16-32	25-40
	Screw	I60M3.5x12 (2.7 Nm)	I60M5x17 (6.7 Nm)
	Screw (shim)	SM4x8C	SM5x8.5C
	Shim	MT16-__M	MT22-__M
	Wrench (screw)	WT15IP	WT20IP

Insert



Medium Cut  
A467

System code > A492

Grade selection > A465

Technical info > A501

Cutting data > A500



A

Turning

B

Milling

C

Drilling

D

Technical Information

E

Index

### Threading tool holder (external)

SWR/L

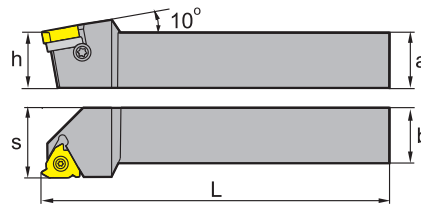
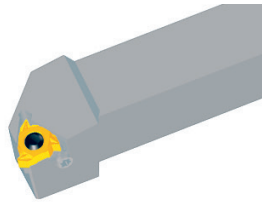

Article	*	Stock	Dimensions [mm]					Inserts
			a	b	L	h	s	
SWL1616H16		●	16	16	100	16	20	LT16.01W-****
SWL2020K16		●	20	20	125	20	25	LT16.01W-****
SWL2525M16		●	25	25	150	25	32	LT16.01W-****
SWL3225P16		●	32	25	170	32	32	LT16.01W-****
SWL3232P16		○	32	32	170	32	40	LT16.01W-****
SWL2525M22		●	25	25	150	25	32	LT22.01W-****
SWL3225P22		○	32	25	170	32	32	LT22.01W-****
SWL3232P22		●	32	32	170	32	40	LT22.01W-****
SWL4040S22		○	40	40	250	40	50	LT22.01W-****

● Ex stock ○ On demand

\* With internal cooling

Spare parts			
	Insert	LT16.01W-****	LT22.01W-****
	h	16-32	25-40
	Screw	I60M3.5×12 (2.7 Nm)	I60M5×17 (6.7 Nm)
	Screw (shim)	SM4×8C	SM5×8.5C
	Shim	MT16-__M	MT22-__M
	Wrench (screw)	WT15IP	WT20IP

Insert
Medium Cut
A467

System code > A492

Grade selection > A465

Technical info > A501

Cutting data > A500

### Threading tool holder (internal)

SNR/L

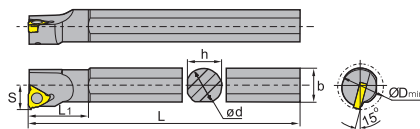

Article	*	Stock	Dimensions [mm]							Inserts
			ød	b	L	h	s	L <sub>1</sub>	D <sub>min</sub>	
SNR0016K11	●	●	16	16	125	15	10	20.9	12	RT11.01N-****
SNR0016M11	●	●	16	15.5	150	15	10.5	25.9	16	RT11.01N-****
SNR0016M16	●	●	16	15.5	150	15	12	27	20	RT16.01N-****
SNR0020M16	●	●	20	19	150	18	14	28.7	25	RT16.01N-****
SNR0020Q16	●	●	20	19	180	18	14	34	25	RT16.01N-****
SNR0025M16	●	●	25	24	150	23	17	28.8	32	RT16.01N-****
SNR0032R16	●	●	32	31	200	30	22	30.9	40	RT16.01N-****
SNR0032S16	●	●	32	31	250	30	22	30.9	40	RT16.01N-****
SNR0040T16	●	●	40	38.5	300	37	27	31.5	50	RT16.01N-****
SNR0050U16	○	○	50	49.5	350	49	35	40.2	63	RT16.01N-****
SNR0020Q22	●	●	20	21.5	180	18	15	35	25	RT22.01N-****
SNR0025R22	●	●	25	24	200	23	19	39	32	RT22.01N-****
SNR0032S22	●	●	32	31	250	30	22	36.4	40	RT22.01N-****
SNR0040T22	●	●	40	38.5	300	37	27	37.2	50	RT22.01N-****
SNR0050U22	●	●	50	48.5	350	47	35	42.6	63	RT22.01N-****

● Ex stock ○ On demand

\* With internal cooling

Spare parts						
	Insert	RT11.01N-****	RT16.01N-****	RT16.01N-****	RT22.01N-****	RT22.01N-****
	ød	16	16	20-50	20	25-50
	Screw	I60M2.5x6.5 (1.0 Nm)	I60M3.5x8 (2.7 Nm)	I60M3.5x12 (2.7 Nm)	I60M5x10 (6.7 Nm)	I60M5x17 (6.7 Nm)
	Screw (shim)			SM4x8C		SM5x8.5C
	Shim			MT16-__M		MT22-__M
	Wrench (screw)	WT07IP	WT15IP	WT15IP	WT20IP	WT20IP

Insert



Medium Cut

A467

System code > A492

Grade selection > A465

Technical info > A501

Cutting data > A500





### Threading tool holder (internal)

SNR/L

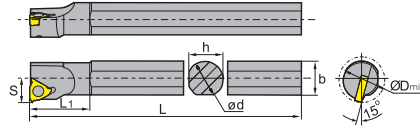

Article	*	Stock	Dimensions [mm]								Inserts
			ød	b	L	h	s	L <sub>1</sub>	D <sub>min</sub>		
SNL0016K11	●	●	16	16	125	15	10	20.9	12	LT11.01N-****	
SNL0016M11	●	●	16	15.5	150	15	10.5	25.9	16	LT11.01N-****	
SNL0016M16	●	●	16	15.5	150	15	12	27	20	LT16.01N-****	
SNL0020M16	○	○	20	19	150	18	14	28.7	25	LT16.01N-****	
SNL0020Q16	●	●	20	19	180	18	14	34	25	LT16.01N-****	
SNL0025M16	●	●	25	24	150	23	17	28.8	32	LT16.01N-****	
SNL0032R16	●	●	32	31	200	30	22	30.9	40	LT16.01N-****	
SNL0032S16	○	○	32	31	250	30	22	30.9	40	LT16.01N-****	
SNL0040T16	●	●	40	38.5	300	37	27	31.5	50	LT16.01N-****	
SNL0050U16	○	○	50	49.5	350	49	35	40.2	63	LT16.01N-****	
SNL0020Q22	●	●	20	21.5	180	18	15	35	25	LT22.01N-****	
SNL0025R22	○	○	25	24	200	23	19	39	32	LT22.01N-****	
SNL0032S22	●	●	32	31	250	30	22	36.4	40	LT22.01N-****	
SNL0040T22	●	●	40	38.5	300	37	27	37.2	50	LT22.01N-****	
SNL0050U22	●	●	50	48.5	350	47	35	42.6	63	LT22.01N-****	

● Ex stock ○ On demand

\* With internal cooling

Spare parts						
	Insert	LT11.01N-****	LT16.01N-****	LT16.01N-****	LT22.01N-****	LT22.01N-****
	ød	16	16	20-50	20	25-50
	Screw	I60M2.5×6.5 (1.0 Nm)	I60M3.5×8 (2.7 Nm)	I60M3.5×12 (2.7 Nm)	I60M5×10 (6.7 Nm)	I60M5×17 (6.7 Nm)
	Screw (shim)			SM4×8C		SM5×8.5C
	Shim			MT16-__M		MT16-__M
	Wrench (screw)	WT07IP	WT15IP	WT15IP	WT20IP	WT20IP

Insert



**Medium Cut**  
A467

System code > A492

Grade selection > A465

Technical info > A501

Cutting data > A500

## Threading tool holder (external)

### SWR-B Thin Type

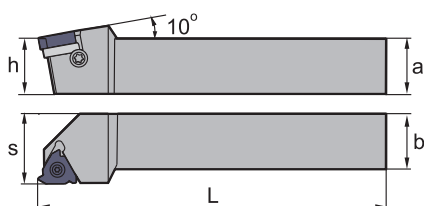
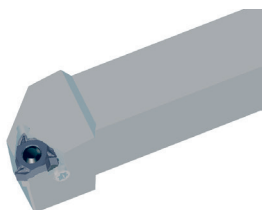

Article	*	Stock	Dimensions [mm]					Inserts
			a	b	L	h	s	
SWR1616H16B		●	16	16	100	16	20	RT16.01W-****B
SWR2020K16B		●	20	20	125	20	25	RT16.01W-****B
SWR2525M16B		●	25	25	150	25	32	RT16.01W-****B
SWR3225P16B		●	32	25	170	32	32	RT16.01W-****B
SWR3232P16B		●	32	32	170	32	40	RT16.01W-****B

● Ex stock   ○ On demand

\* With internal cooling

Spare parts		
	Insert	RT16.01W-****B
	h	16-32
	Screw	I60M3.5x12TT (2.7 Nm)
	Screw (shim)	SM4x8C
	Shim	MT16-__M
	Wrench (screw)	WT15IP

Insert
Medium Cut
A486

System code > A492

Grade selection > A465

Technical info > A501

Cutting data > A500

### Threading tool holder (internal)

SNR-B Thin Type

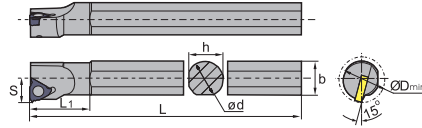
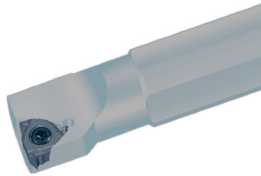

Article	*	Stock	Dimensions [mm]							Inserts
			ød	b	L	h	s	L <sub>1</sub>	D <sub>min</sub>	
SNR0016M16B	●		16	15.5	150	15	12	27	20	RT16.01N-****B
SNR0020Q16B	●		20	19	180	18	14	34	25	RT16.01N-****B
SNR0025M16B	●		25	24	150	23	17	28.8	32	RT16.01N-****B
SNR0032R16B	●		32	31	200	30	22	30.9	40	RT16.01N-****B
SNR0032S16B	●		32	31	250	30	22	30.9	40	RT16.01N-****B

● Ex stock    ○ On demand

\* With internal cooling

Spare parts			
	Insert	RT16.01N-****B	RT16.01N-****B
	ød	16	20-32
	Screw	I60M3.5x08TT (2.7 Nm)	
	Screw		I60M3.5x12TT (2.7 Nm)
	Screw (shim)		SM4x8C
	Shim		MT16-__M
	Wrench (screw)	WT15IP	WT15IP

System code > A492

Grade selection > A465

Technical info > A501

Cutting data > A500



## Threading inserts

Material group	Composition / structure / heat treatment		Brinell hardness HB	Machining group	Starting values for cutting speed $v_c$ [m/min]			
					HC (PVD)			
					YBG201	YBG205		
<b>P</b> Unalloyed steel  Low-alloyed steel  High-alloyed steel and high-alloyed tool steel	approx. 0,15 % C	annealed	125	1	190	190		
		approx. 0,45 % C	annealed	190	2	175	175	
		approx. 0,45 % C	tempered	250	3	145	145	
		approx. 0,75 % C	annealed	270	4	140	140	
	approx. 0,75 % C	tempered	300	5	135	135		
		annealed	180	6	170	170		
		tempered	275	7	125	125		
	High-alloyed steel and high-alloyed tool steel	tempered	300	8	115	115		
		tempered	350	9	105	105		
	<b>M</b> Stainless steel	ferritic/martensitic	annealed	200	12	165	165	
martensitic		tempered	240	13	135	135		
austenitic		quench hardened	180	14	155	155		
austenitic-ferritic			230	15	135	135		
perlitic/ferritic			180	16	240	240		
<b>K</b> Grey cast iron  Cast iron with spheroidal graphite  Malleable cast iron	perlitic (martensitic)		260	17	185	185		
	ferritic		160	18	220	220		
	perlitic		250	19	165	165		
	ferritic		130	20	175	175		
	perlitic		230	21	165	165		
<b>N</b> Aluminium wrought alloys  Cast aluminium alloys  Copper and copper alloys (bronze/brass)	cannot be hardened		60	22	800	800		
	hardenable	hardened	100	23	600	600		
	$\leq 12\% \text{ Si}$ , cannot be hardened		75	24	320	320		
	$\leq 12\% \text{ Si}$ , hardenable	hardened	90	25	240	240		
	$> 12\% \text{ Si}$ , cannot be hardened		130	26	160	160		
	machining steel, PB > 1%		110	27	160	160		
	CuZn, CuSnZn		90	28	600	600		
<b>S</b> Heat-resistant alloys  Titanium alloys	Fe-based alloys	annealed	200	30	95	95		
		hardened	280	31	50	50		
		annealed	250	32	80	80		
		hardened	350	33	70	70		
	Ni or Co bass	cast	320	34	70	70		
		pure titanium		$R_m$ 400	35	145	145	
	$\alpha$ and $\beta$ alloys	hardened		$R_m$ 1050	36	50	50	
<b>H</b> Hardened steel  Hard cast iron  Hardened cast iron		hardened and tempered	55 HRC	37				
		hardened and tempered	60 HRC	38				
		cast	400	39				
<b>X</b> Non-metallic materials		hardened and tempered	55 HRC	40				
	Thermoplasts			41				
	Thermosetting plastics			42				
	Plastic, glass-fibre reinforced GFRP			43				
	Plastic, carbon fibre reinforced CFRP			44				
Graphite			45					
Wood			46					

Note: The given cutting values are guide values, which were determined under ideal conditions. The values have to be adapted in individual cases. For examples of material for cutting tool groups view page D11.

HC Coated carbide

## Technical information

Trouble shooting - turning

A502-A504

Technical Information - turning

A505-A512

Special tools – turning

A513

# A

**A**

Turning

**B**

Milling

**C**

Drilling

**D**

Technical  
Information

**E**

Index

## Trouble shooting – general turning

Fig.	Type of wear	Effects	Reason	Countermeasure
1+2	Flank wear	<ul style="list-style-type: none"> <li>– Bad surface quality and dimensional stability</li> <li>– Increase of cutting force</li> </ul>	<ul style="list-style-type: none"> <li>– Grade not wear-resistant enough</li> <li>– Cutting speed too high</li> <li>– Clearance angle too small</li> <li>– Feed rate too low</li> </ul>	<ul style="list-style-type: none"> <li>– Grade with higher wear-resistance</li> <li>– Reduce cutting speed</li> <li>– Increase clearance angle</li> <li>– Reduce feed rate</li> </ul>
3	Crater wear	<ul style="list-style-type: none"> <li>– Bad surface quality and chip control</li> </ul>	<ul style="list-style-type: none"> <li>– Grade not wear-resistant enough</li> <li>– Cutting speed too high</li> <li>– Feed rate too low</li> </ul>	<ul style="list-style-type: none"> <li>– Grade with higher wear-resistance</li> <li>– Reduce cutting speed</li> <li>– Reduce feed rate</li> </ul>
4	Chipping	<ul style="list-style-type: none"> <li>– Unstable tool life</li> <li>– Sudden breakage of cutting edge</li> </ul>	<ul style="list-style-type: none"> <li>– Grade too hard</li> <li>– Feed rate too high</li> <li>– Cutting edge not stable enough</li> <li>– Stability of the holder or tension insufficient</li> </ul>	<ul style="list-style-type: none"> <li>– Grade with higher toughness</li> <li>– Reduce feed rate</li> <li>– Change honing of cutting edge</li> <li>– Use a more stable tool holder</li> </ul>
5	Breakage	<ul style="list-style-type: none"> <li>– Increase of cutting force</li> <li>– Bad surface quality and dimensional stability</li> </ul>	<ul style="list-style-type: none"> <li>– Grade too hard</li> <li>– Feed rate too high</li> <li>– Cutting edge not stable enough</li> <li>– Stability of the holder or tension insufficient</li> </ul>	<ul style="list-style-type: none"> <li>– Grade with higher toughness</li> <li>– Reduce feed rate</li> <li>– Change honing of cutting edge</li> <li>– Use a more stable tool holder</li> </ul>
6	Plastic deformation	<ul style="list-style-type: none"> <li>– Bad dimensional stability</li> <li>– Damage to cutting edge</li> </ul>	<ul style="list-style-type: none"> <li>– Grade not wear-resistant enough</li> <li>– Cutting speed too high</li> <li>– Cutting depth and/or feed rate too high</li> <li>– Temperature on the cutting edge too high</li> </ul>	<ul style="list-style-type: none"> <li>– Grade with higher toughness</li> <li>– Reduce cutting speed</li> <li>– Reduce cutting depth and feed rate</li> <li>– Grade with higher heat-resistance</li> </ul>
7	Welding	<ul style="list-style-type: none"> <li>– Increase of cutting force</li> <li>– Bad surface quality</li> </ul>	<ul style="list-style-type: none"> <li>– Cutting speed too low</li> <li>– Cutting edge not sharp enough</li> <li>– Grade not suitable</li> </ul>	<ul style="list-style-type: none"> <li>– Increase cutting speed</li> <li>– Increase rake angle</li> <li>– Use a more suitable grade</li> </ul>
8	Thermal cracks	<ul style="list-style-type: none"> <li>– Breakage due to thermal interaction, often caused when cutting is interrupted (milling)</li> </ul>	<ul style="list-style-type: none"> <li>– Temperature fluctuation when machining</li> <li>– Grade too hard</li> </ul>	<ul style="list-style-type: none"> <li>– Dry machining</li> <li>– Grade with higher toughness</li> </ul>
9	Notch wear	<ul style="list-style-type: none"> <li>– Burr formation</li> <li>– Increase of cutting force</li> </ul>	<ul style="list-style-type: none"> <li>– Damage through chips (jagged edges)</li> <li>– Feed rate and cutting speed too high</li> </ul>	<ul style="list-style-type: none"> <li>– Grade with higher wear-resistance</li> <li>– Increase rake angle to get a sharper cutting edge</li> <li>– Reduce cutting speed</li> </ul>
10	Flaking (coating)	<ul style="list-style-type: none"> <li>– Often appears when machining hardened materials or caused by vibration</li> </ul>	<ul style="list-style-type: none"> <li>– Cutting edge adhesion and chipping</li> <li>– Bad chip removal</li> </ul>	<ul style="list-style-type: none"> <li>– Increase rake angle to get a sharper cutting edge</li> <li>– Chip breaker with bigger chip space</li> </ul>

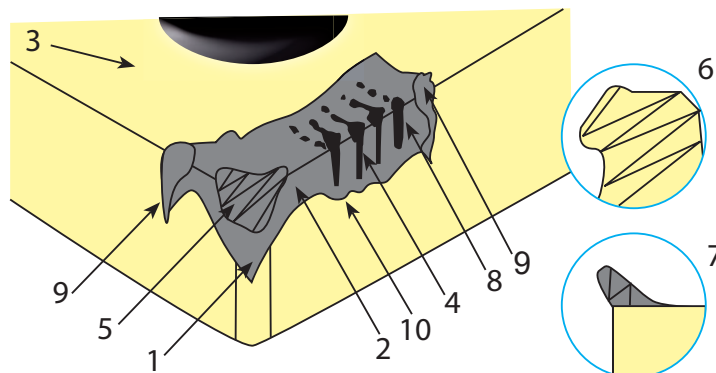

A

Turning

B

Milling

C

Drilling

D

Technical Information

E

Index

**Trouble shooting – PCBN & PCD**

Type of wear	Countermeasure	
	Geometry	Cutting condition
Flank wear	<ul style="list-style-type: none"> <li>- Sharper cutting edge for reduced cutting force</li> <li>- Smaller negative chamfer</li> <li>- Use positive inserts</li> </ul>	<ul style="list-style-type: none"> <li>- Reduce cutting speed</li> <li>- Increase feed rate to reduce operation time</li> </ul>
Notch wear	<ul style="list-style-type: none"> <li>- Bigger radius</li> </ul>	<ul style="list-style-type: none"> <li>- Use "method of altering feed rate"</li> </ul>
Crater wear/breakage due to crater wear	<ul style="list-style-type: none"> <li>- Sharper cutting edge for reduced cutting force</li> </ul>	<ul style="list-style-type: none"> <li>- Reduce cutting speed</li> <li>- Increase feed rate to minimise operation time and to increase distance between cutting edge and crater</li> </ul>
Chipping due to rough condition or vibration	<ul style="list-style-type: none"> <li>- Bigger negative chamfer angle and/or honed chamfer</li> </ul>	<ul style="list-style-type: none"> <li>- Increase feed rate to reduce number of hits</li> </ul>
Flaking	<ul style="list-style-type: none"> <li>- Sharper cutting edge to reduce cutting force</li> <li>- Smaller negative chamfer</li> <li>- Use positive inserts</li> </ul>	<ul style="list-style-type: none"> <li>- Increase feed rate to reduce operation time</li> </ul>
Thermal crack/breakage	<ul style="list-style-type: none"> <li>- Sharper cutting edge for reduced cutting force</li> <li>- Smaller negative chamfer</li> <li>- Use positive inserts</li> </ul>	<ul style="list-style-type: none"> <li>- Reduce cutting speed, feed rate and depth of cut</li> <li>- Dry machining</li> </ul>
Chipping	<ul style="list-style-type: none"> <li>- Bigger negative chamfer</li> </ul>	<ul style="list-style-type: none"> <li>- Increase cutting speed to reduce cutting force</li> </ul>

For investigation please send us the used inserts. If breakage is the problem please use inserts only 80–90% of expected tool life because broken inserts almost have no information.

**A**

Turning

**B**

Milling

**C**

Drilling

**D**

Technical Information

**E**

Index



### Trouble shooting – threading

Problème	Cause	Solution
Big flank wear	– Cutting speed too high	– Reduce cutting speed
	– Width of cut too small	– Reduce number of width of cut
	– Insert over/under centre line	– Adjust insert height
Asymmetric wear on left and right cutting edge	– Width of cut not optimal	– Adjust width of cut
	– Inclination angle and lead angle are not optimally aligned	– Change the shim to get the correct angle
Breakage	– Cutting speed too low	– Increase cutting speed
	– Cutting force too high	– Increase number of width of cut – Reduce width of cut
	– Unstable conditions	– Improve clamping and overhang to avoid vibrations
	– Bad chip control	– Increase coolant pressure for better chip removal
Déformation plastique	– Cutting speed and temperature too high	– Reduce cutting speed – Increase number of width of cut – Reduce width of cut
	– Insufficient coolant supply	– Improve coolant supply
Mauvais état de surface du filet	– Cutting speed too low	– Increase cutting speed
	– Insert over/under centre line	– Adjust insert height
	– Bad chip control	– Change feed rate and/or width of cut
Profil de filet incorrect	– Incorrect insert height	– Change insert height
	– Tool holder doesn't form a 90° angle	– Adjust tool holder
	– Pitch error in machine	– Adjust machine
Profil de filetage de profondeur insuffisante	– Incorrect insert height	– Change insert height
	– Breakage of cutting edge	– Change insert
	– Excessive wear	– Change insert
Formation d'arêtes rapportées	– Temperature on cutting edge is too low	– Increase cutting speed
	– Often occurs when machining of carbon steel and stainless steel	– Use grade with sufficient toughness (PVD coated)
Vibrations	– Incorrect cutting data	– Increase or highly decrease cutting speed
	– Incorrect insert height	– Change insert height
	– Insufficient clamping	– Improve clamping system and minimise overhang

A

Turning

B

Milling

C

Drilling

D

Technical Information

E

Index

## General turning

### Cutting tool geometry

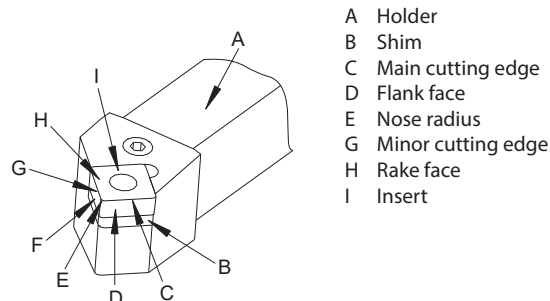
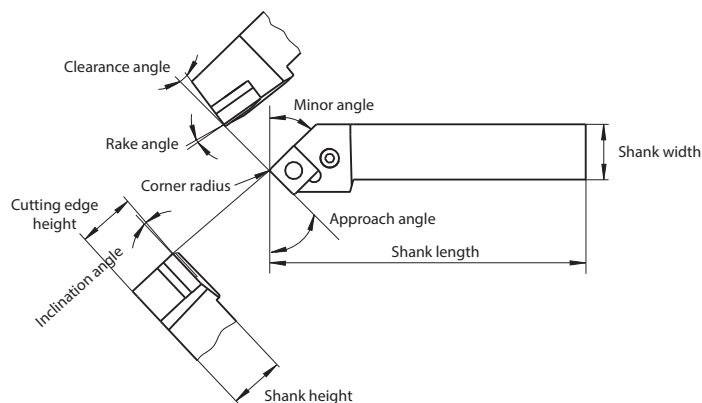

- A Holder
- B Shim
- C Main cutting edge
- D Flank face
- E Nose radius
- G Minor cutting edge
- H Rake face
- I Insert

### Rake angle

The rake angle is a cutting edge angle that has large effects on cutting resistance, chip disposal, cutting temperature and tool life. Increasing the rake angle in positive direction improves the sharpness of the cutting edge and the cutting force decreases but at the same time it lowers the strength. To increase the cutting resistance the rake angle must be increased in negative direction.

Rake angle	Applications
Small	Machining of fragile and hard materials, roughing and interrupted cut
Large	Machining of plastic materials and soft materials, precision machining

### Clearance angle

The flank angle prevents friction between the flank face and work piece resulting in smooth feed. Increasing the flank angle decreases the cutting force and the surface roughness becomes better but on the other hand this lowers the cutting edge strength and decreases the flank wear occurrence.

Clearance angle	Applications
Small	Machining of hard and demure materials, for roughing operation with stable cutting edge
Large	Precision machining with low cutting force, work pieces suffer from work hardening easily

### Inclination angle

The positive and negative edge inclination angle determines the discharging direction of chips. In heavy cutting, the cutting edge receives extremely large shocks at the beginning of cutting. Cutting edge inclination keeps the cutting edge from receiving this shock and prevents fracturing. On the other hand the back force increases and occurs vibration. For a finishing operation a positive angle is more suitable.

When the edge inclination angle is negative, i.e. the cutting edge is located at the lowest point relative to the bottom plane of the tool holder, the chips flow to the machined surface of workpiece.

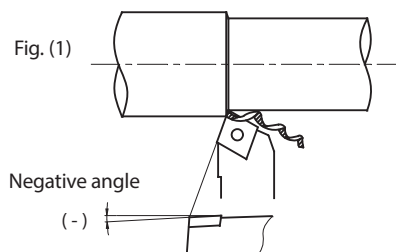

As shown in Fig. (2), when the edge inclination angle is positive, i.e. the cutting edge is located at the highest point relative to the bottom plane of the tool holder, the chips flow to the un-machined surface of workpiece.

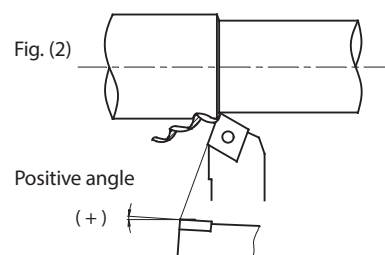

A

Turning

B

Milling

C

Drilling

D

Technical Information

E

Index

A

Turning

### General turning

#### Entering angle (main cutting edge)

Reducing the lead angle increases the strength of the cutting edge. Because the lead angle is small, the cutting width is long, the force on the unit cutting edge length is small. At the same time, reducing the lead angle can increase the tool life. Normally, when turning thin long shaft and ladder shaft, the lead angle adapts 90°. The lead angle is increased, radial force is reduced, cutting is stable, cutting thickness is increased and chip breaking performance is good.

Entering angle	Applications
Small	For material with high tensile strength, high hardness or hardened layer on surface
Large	For machining with low rigidity

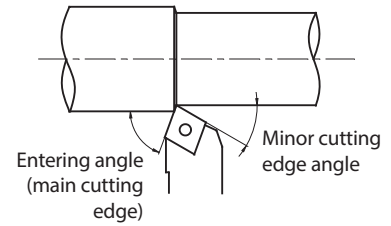

B

Milling

#### Minor cutting edge

The minor cutting edge angle is the main angle on influence surface roughness; its size is also influence strength of cutter. When the minor cutting edge angle is too small, the cutting force increases and results in chattering and vibration. The selection principle for the minor cutting edge angle is under the condition of rough machining, or un-influencing friction and producing vibration, the smaller angle should be chosen; the bigger angle can be used for precision machining.

#### Nose radius

The nose radius effects the cutting edge strength and the finished surface. By increasing the nose radius the surface finish becomes better and the cutting edge strength improves. Flank and rake wear decreases. If the radius becomes too big, the cutting force increases and causes vibration which effects the chip control negative.

Radius	Applications
Small	Finishing with small cutting depth, machining thin long shaft, rigidity of machine is insufficient
Large	Rough machining, high cutting edge strength is required, rigidity of machine is good, machining hardened materials and interrupted cut

C

Drilling

D

Technical Information

E

Index

General turning

Cutting speed  $V_c$

$$V_c = \frac{\pi \times D \times n}{1000} \text{ [m/min]}$$

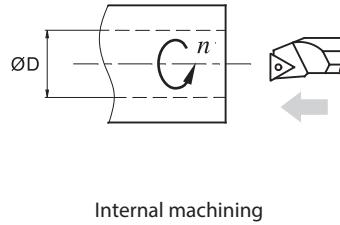
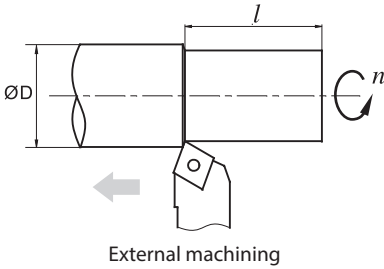

$V_c$ : Cutting speed [m/min]  
 $n$ : Revolution [1/min]  
 $f$ : Feed rate [mm]

Example:  $n = 250$  1/min,  $f = 0,2$  mm,  
 $l = 150$  mm  
 Result: [insert values in formula  $V_c$ ]

Feed rate  $F$

$$f = \frac{l}{n} \text{ [mm/rev]}$$

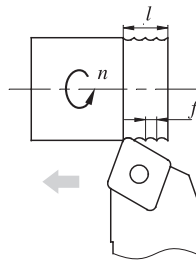

$f$ : Feed rate [mm]  
 $l$ : Cutting length [mm/min]  
 $n$ : Revolution [1/min]

Example:  $n = 500$  1/min,  $l = 100$  mm/min  
 Result: [insert values in formula  $f$ ]

$$f = \frac{l}{n} = \frac{100}{500} = 0,2 \text{ mm}$$

Cutting time  $T_c$

$$T_c = \frac{l}{f \times n} \text{ [min]}$$

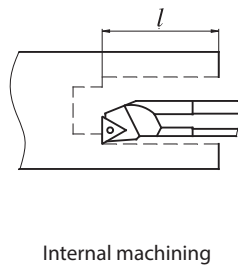
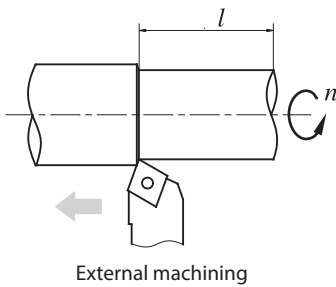

$T_c$ : Cutting time [min]  
 $l$ : Cutting length [mm/min]  
 $f$ : Feed rate [mm]  
 $n$ : Revolution [1/min]

Example:  $n = 250$  1/min,  $f = 0,2$  mm,  
 $l = 150$  mm  
 Result: [insert values in formula  $T_c$ ]

A

Turning

B

Milling

C

Drilling

D

Technical Information

E

Index

A

## General turning

Cutting time  $T_C$  for face milling

$$T_C = \frac{\pi \times (a^2 - b^2)}{4000 \times V_C \times f} \text{ [min]}$$

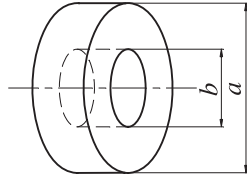

$T_C$ : Cutting time [min]  
 $V_C$ : Cutting speed [m/min]  
 $f$ : Feed rate [mm]

Turning

B

Theoretical surface roughness R

$$R = \frac{f^2}{8r_c} \times 1000 \text{ [}\mu\text{m]}$$

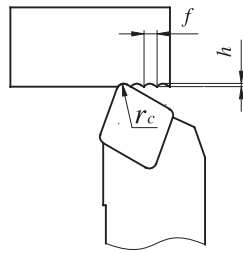

R: Surface roughness [ $\mu\text{m}$ ]  
 $f$ : Feed rate [mm]  
 $r_c$ : Radius of insert [mm]

Example:  $f = 0,2 \text{ mm}$ ,  
 $r_c = 0,4 \text{ mm}$

Milling

C

Drilling

D

Technical  
Information

E

Index

## General turning

### Three effects of cutting condition for turning

Today short machining time, long tool life and high machining accuracy is expected from modern tools. Based on the machine performance, material shape and hardness of the components the right choice of tool and cutting conditions are the premise for a successful machining process. Cutting speed, feed rate and depth of cut are what we call the “Three effects of cutting”.

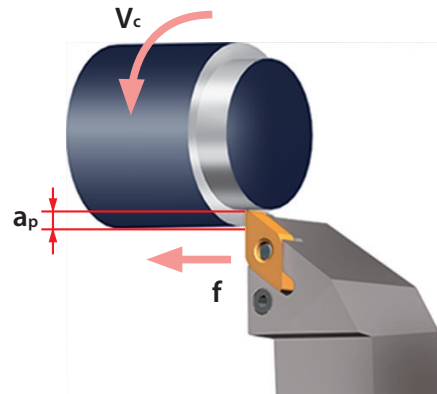

#### 1. Cutting speed ( $V_c$ )

Cutting speed is defined as the rate (or speed) that the material moves past the cutting edge of the tool. The unit for  $V_c$  is meter per minute [m/min].

**Cutting speed influence:** Cutting speed is one of the three important effects of turning and has influence on tool life. Increasing the cutting speed also increases the cutting temperature and that decreases the tool life. Depending on the hardness and type of material the cutting speed varies. Therefore to choose a suitable grade for the cutting speed is necessary.

In general situation, when cutting speed is increased by 20% the tool life will be reduced  $\frac{1}{2}$ ; when the cutting speed is increased by 50% the tool life decreases  $\frac{1}{3}$ . Lower cutting speed results in vibration which will shorten tool life.

#### 2. Feed rate ( $f$ )

In turning application feed rate is the distance the tool holder moves per work piece revolution. That has influence to the surface quality. The unit for feed rate is millimetre per revolution [mm/rev]

**Feed rate influence:** Decreasing the feed rate will increase flank wear and tool life will be shortened. Increasing the feed rate increases the cutting temperature and also flank wear. On the other hand the efficiency will be improved.

#### 3. Depth of cut ( $a_p$ )

The depth of cut refers to the half different value between the diameter of the unmachined and machined work piece. The unit is millimetre [mm].

**Depth of cut influence:** Changing depth of cut has no big influence to the tool life. Machining hardened layer with small depth of cut results in friction and short tool life. Machining uncut surface or cast iron material, choose maximum depth of cut according to the machine power so that the cutting edge and corner radius is out of the hardened layer. That helps to prevent chipping and abnormal wear.

A

Turning

B

Milling

C

Drilling

D

Technical Information

E

Index

A

## Parting & grooving

### Adjusting the cutting edge height

- Mount the tool holder in a 90° angle to the central axis of the workpiece. This improves the surface quality and decreases the risk of vibrations.

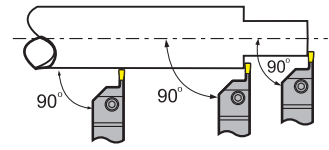

- Height tolerance between the cutting edge of the insert and the centre of the work piece should be kept  $\pm 0.1$  mm, especially for parting of rods and grooving of materials with a small diameter. This extends the tool life and reduces the cutting forces as well as the formation of burrs.

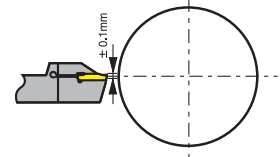

Turning

B

### Parting off

- When the cutting edge nears the central axis of the work piece, reducing the feed rate by 30 % can extend the tool life of the insert.
- Pick a tool holder with the smallest possible overhang to avoid vibrations and tool deflection.

Milling

C

### Longitudinal turning and profile turning

- Machining sequence 0.5 mm:
  1. Bring radial feed rate to required cutting depth (ap max.  $0.75 \times$  cutting edge width)
  2. Radial relocating by 0.1 mm
  3. Longitudinal turning to opposite shoulder
  4. Diagonal relocating by 0.5 mm outward axial feed rate to the starting point
  5. Radial feed rate to required cutting depth, etc.

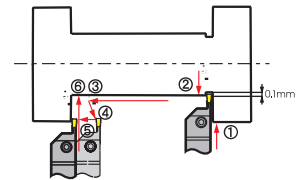

- When machining the chamfer or the base of the slot follow the steps as shown in figure. This reduces tool deflection and avoids cutting edge chipping.

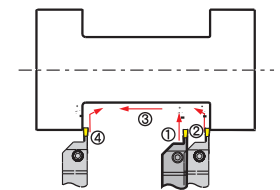

Drilling

D

### Surface grooving and turning

- Roughing: Processing from largest diameter to the axis. When returning it's recommended to bend the tool slightly.

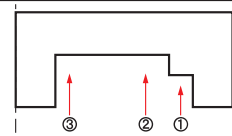

- Flute turning: Depth of axial turning less than  $0.75 \times S$  (width of insert). When the pocket width is bigger than the depth follow the working steps as shown. When the pocket depth is bigger than the width, we recommend to go to the required diameter step by step.

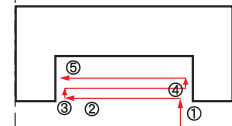

- Finishing: When finishing begin with the outer diameter and the bottom. Then go on with the inner diameter to the required size.

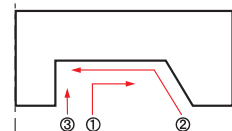

Technical Information

E

### Internal machining

- Procedure according to figure. For better chip removal in blind holes machine from the inside out.

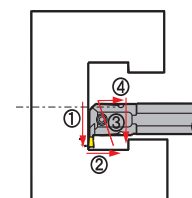

Index

## Threading

### Steps for best results when thread-cutting

1. Choice of threading method
2. Choice of angle and shim
3. Choice of tool holder and inserts
4. Choice of cutting data
5. Choice of cutting direction

### Thread turning method

#### External machining

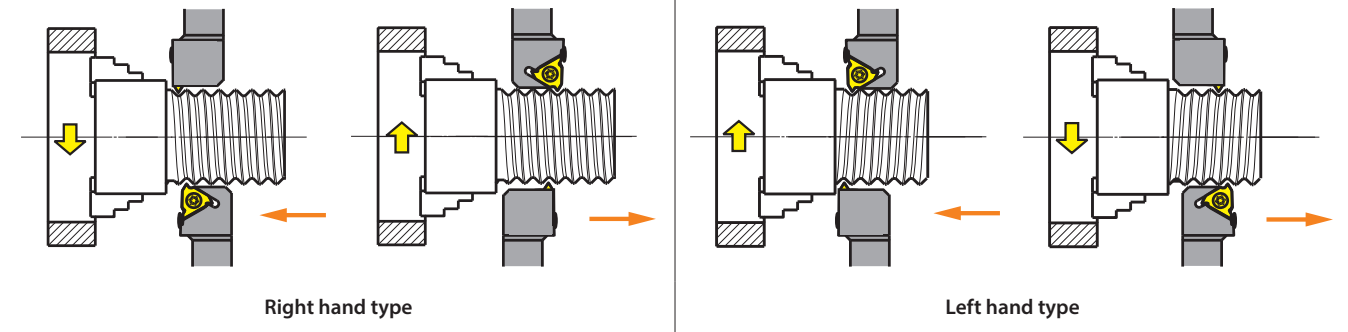

#### Internal machining

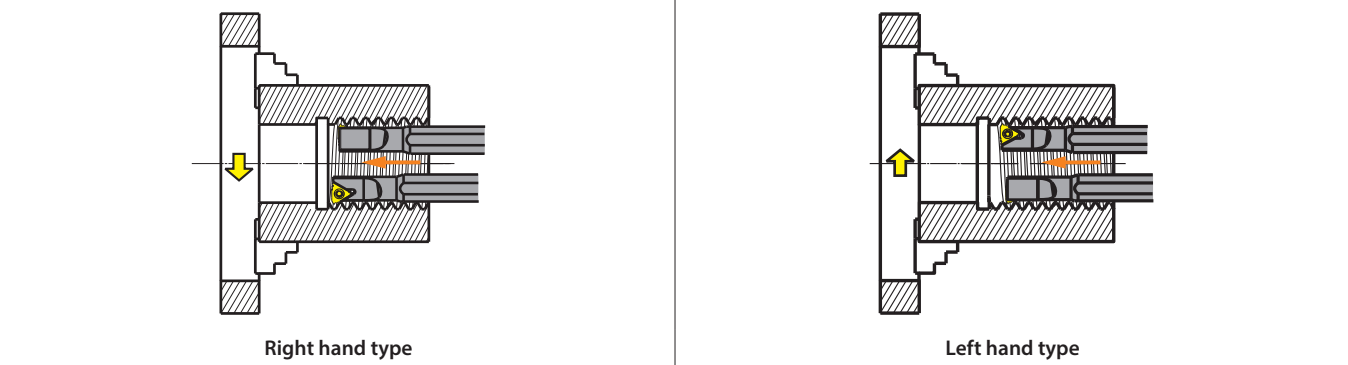

A

Turning

B

Milling

C

Drilling

D

Technical Information

E

Index



## Choice of angle and shim

### Choice of angle

The flank clearance angles of the thread profile depend on the helical angle of the thread. The helical angle of the thread must coincide with the insert's angle of inclination angle as far as possible to get the ideal profile, to avoid longer unfavourable wear on one of the flanks and thus to ensure tool life.

$$\lambda = \arctan \frac{p}{d_2 \times \pi}$$

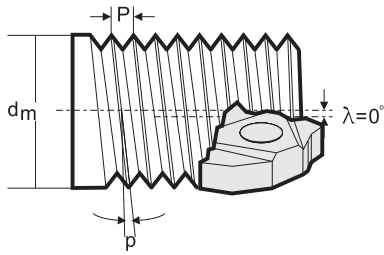

Helix angle (p)

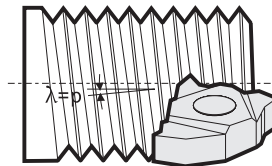

Pitch angle (λ)

p Pitch  
d<sub>2</sub> Flank diameter  
λ Pitch angle

### Choice of shim

Pitch range	Dimension	Pitch angle	Shim
0,5–0,3	16	0	MT16-00M
		1	MT16-01M
		2	MT16-02M
		3	MT16-03M
3,5–6,0	22	0	MT22-00M
		1	MT22-01M
		2	MT22-02M
		3	MT22-03M

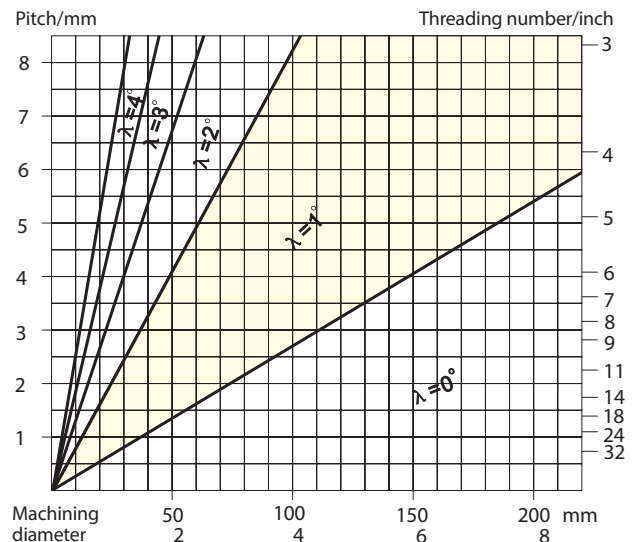

The shim  $\lambda = 1^\circ$  is delivered with the tool holder.

### Infeed way of threading

The number of passes and widths of cut are the key points of threading operation. Please choose the cutting parameters with the recommended form according to experience data. In case of breakages or too much wear please have a look at page A447 (trouble shooting).

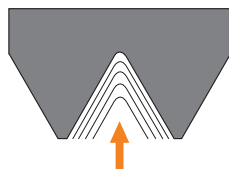

Radial width of cut

Radial width of cut requires low cutting depth, sharp cutting edge and tough grade. It is recommended when the pitch is smaller than 2 mm, not ideal for material with long chips.

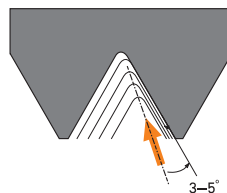

Modified flank width of cut

Infeed at an angle of 3–5° to the flank of the teeth. It is easy for chips flow. Suitable for long chip material and internal threading.

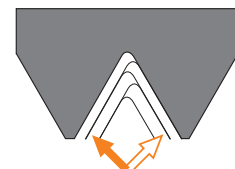

Alternating width of cut

Alternating width of cut is mainly used for large pitches and long chip materials. To get equal insert wear on both edges.

# Go directly to the special tool tailored for your turning applications

Are there turning applications at your company where having custom tools tailored to your unique needs would deliver real benefits both in terms of logistics and at a technical and commercial level? ZCC Cutting Tools Europe is there to advise and assist you during the planning, development and ordering process. Use our new online tool to request a special tool and get your personal quotation in just a few short steps (<https://www.zcct-europe.com/en/tools/special-tools/>).

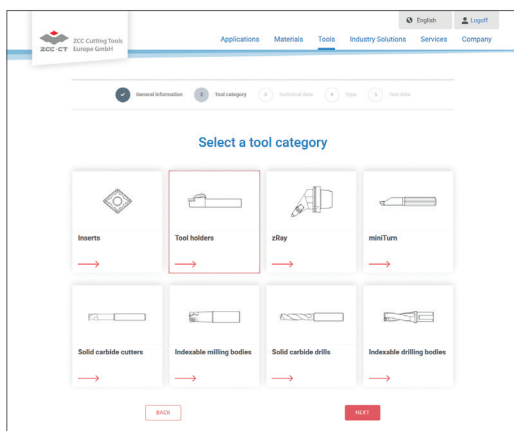

'Online tool for special tools' launch page where you can select the tool category

## Selecting the tool category

Scan the QR code on this page to go directly to the launch page of our online tool where you can request the special tool you need. You can begin by selecting the tool category you need. It's that easy.

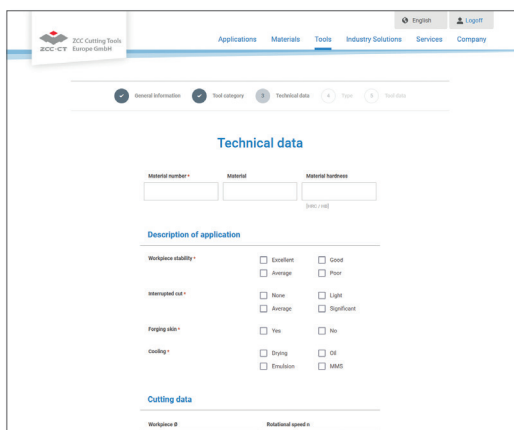

Define the relevant tool parameters.

## Defining the tool parameters

You are now guided step by step through the process. You can also securely upload your drawings, diagrams and 3D models (where available).

It's the easy way to order your custom-made special tool from ZCC Cutting Tools Europe GmbH.



Now go directly to the new **special tool form** on our website and get started.