



Precision meets Motion

WERKZEUGAUFNAHMEN FÜR CNC-DREHMASCHINEN
TOOL HOLDERS FOR CNC-LATHES
PORTE OUTILS POUR CNC-TOURS

EWS
Tool Technologies



Innovation

Die Genialität einer Erfindung liegt im Nutzen, nicht in der Komplexität ihrer Ausführung. Mit unseren Innovationen möchten wir daher die Basis für Ihren Markterfolg schaffen. Genial einfach.

Innovation

The genius of an invention lies in the benefits, not in the complexity of its embodiment. Therefore, our innovations aim at creating the basis for your success in the market. Ingeniously simple.

Innovation

Le génie d'une invention est son utilité et non pas la complexité de sa réalisation. C'est pourquoi nos innovations peuvent être d'un apport fondamental à votre succès commercial. C'est génial.



Inhalt
content
table de matières



Statische Werkzeuge für Scheibenrevolver

Static tools for disc turrets
Porte-outils statiques

1



Prismenaufnahmen nach DIN 69881

Dove tail tool holder according to DIN 69881
Porte-outils prismatiques conforme DIN 69881

2



Angetriebene Werkzeuge

Driven tools
Porte-outils motorisés

3



Werkzeuge für Index / Traub Maschinen

Tools for Index / Traub machines
Porte-outils pour machines Index / Traub

4



Statische- und angetriebene Werkzeuge nach DIN 5480

Static and driven tools according to DIN 5480
Porte-outils statiques et motorisés avec connexion conforme DIN 5480

5



Werkzeuge für Mazak / Okuma / Mori Seiki Maschinen

Tools for Mazak / Okuma / Mori Seiki machines
Porte-outils pour machines Mazak / Okuma / Mori Seiki

6



HSK- und Capto-Werkzeuge

HSK and Capto tools
Porte-outils HSK et Capto

7



EWS Varia

EWS Varia
EWS Varia

8



Statische Werkzeuge für Scheibenrevolver

Static tools for disc turrets

Porte-outils statiques

DIN 69 880 VDI 3425 / 2

Werkzeughalter mit Zylinderschaft
Tool holder with cylindrical shank
Porte-outil cylindrique

			Form	Page
Werkzeughalter vorgearbeitet	Tool blanks	Outils d'ébauche	A1 / A2	1.1
Vierkant-Queraufnahmen	Radial turning tool holder	Porte-outil radial	B1 / B8	1.2 - 1.5
Vierkant-Längsaufnahmen	Axial turning tool holder	Porte-outil axial	C1 / C4	1.6 / 1.7
Vierkant-Mehrfachaufnahmen	Square multi tool holder	Porte-outil carré universal	D1 / D2	1.8
Axial-Werkzeughalter Radial-Axial-Werkzeughalter	Axial-tool holder Radial-axial-tool holder	Porte-outil axial Porte-outil axial-radial		1.9
Radial-Werkzeughalter höhenverstellbar	Radial-tool holder Height adjustable	Porte-outil radial réglable en hauteur		1.10 - 1.13
Axial-Werkzeughalter höhenverstellbar	Axial-tool holder Height adjustable	Porte-outil axial réglable en hauteur		1.14 / 1.15
Zylinderaufnahmen Bohrstangenhalter Reduzierbuchsen	Straight shank tool holders Boring bar holder Reduction sleeves	Porte-outil pour queue cylindrique porte-barre d'alésage Douille de réduction	E2	1.16 - 1.22
Stellhülseaufnahmen	Automotive shank tool holders	Porte-outil réglable		1.22 / 1.23
Werkzeughalter für Bohrwerkzeuge Kegelaufnahmen Whistle Notch Klemmringe	Boring bar holder Morse taper shanks Whistle notch Clamping rings	Porte-outil pour outil d'alésage et queue à cône morse Whistle notch Bague de serrage	E1 F Z1	1.24 - 1.27
Werkzeughalter für Spannzangen Spannzangen Spannschlüssel	Collet chucks Collets Collet chuck wrenches	Porte-pinces Pinces Clés pour porte pince de serrage	E3 / E4	1.28 / 1.29
Werkstoffanschläge Kurzbohrfutter ABS-Aufnahmen Hydro-Drehspannfutter	Stock stop Short drill chuck ABS-adaptors Hydraulic chuck	Butée Mandrins de perçage court monobloc Mandrins ABS Mandrins expansible		1.30 / +1.33
Gewindeschneidköpfe	Tapping heads	Tête de tarandage		1.34 - 1.39
Pendelhalter	Floating holders	Mandrins porte alésoir flottant		1.39 + 1.40
Stangengreifer	Bar gripper	Tire-barre à mâchoire		1.40 + 1.41
Zentrierspitzen	Center points	Pointe de centrage		1.42
Rändelfräswerkzeuge Verschlußstopfen	Knurling tools Blanking plugs	Appareil à moleter Bouchonde protection	Z2	1.43
Einrichtehalter Prüfdorne	Setting holders Test mandrels	Porte-outil de réglage Mandrins de contrôle		1.44
Zubehör	Accessories	Accessories		1.31 + 1.32

Werkzeughalter

vorgearbeitet

DIN 69 880 Teil 2
Form A1 rechteckig

VDI 3425 Bl. 2
Form 0.1

Toolholder Blank

DIN 69 880 Part 2
Form A1 rectangular

VDI 3425 Sheet 2
Form 0.1

Ébauche de Porte outil

DIN 69 880 Partie 2
Forme A1 rectangulaire

VDI 3425 page 2
Forme 0.1

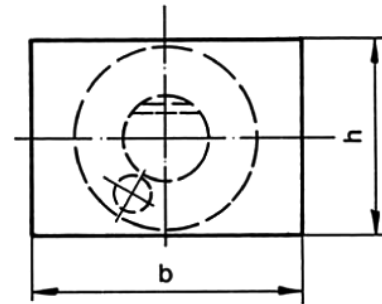
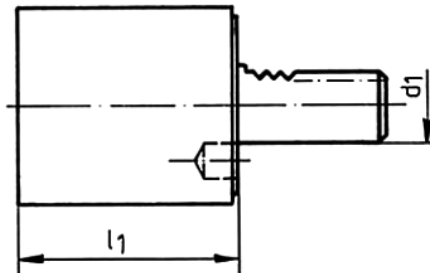

Nr.	d ₁	l ₁	b	h
R 16.44.78.44	16	44	78	44
R 20.50.60.60	20	50	60	60
R 20.65.100.60	20	65	100	60
R 25.75.100.60	25	75	100	60
R 30.85.130.76	30	85	130	76
R 40.100.151.96	40	100	151	96
R 50.125.160.120	50	125	160	120
R 60.160.165.125	60	160	165	125
R 80.200.220.160	80	200	220	160

Werkzeughalter vorgearbeitet in vergüteter Ausführung mit 900 N/mm²
Bestell-Nr. wie oben, jedoch an Stelle R = V, z. B. V 16.44.78.44

Werkzeughalter

vorgearbeitet

DIN 69 880 Teil 2
Form A2 rund

VDI 3425 Bl. 2
Form 0.2

Toolholder Blank

DIN 69 880 Part 2
Form A2 round

VDI 3425 Sheet 2
Form 0.2

Ébauche de Porte outil

DIN 69 880 Partie 2
Forme A2 ronde 2

VDI 3425 page 2
Forme 0.2

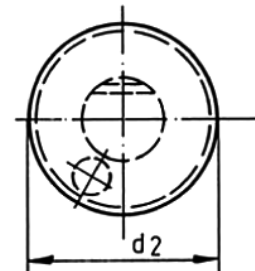
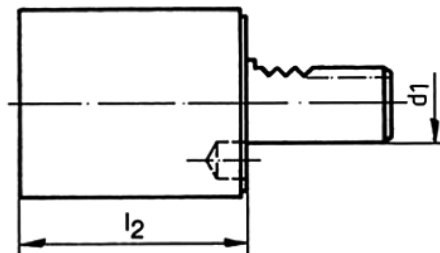

Nr.	d ₁	d ₂	l ₂	Nr.	d ₁	d ₂	l ₂
R 16.40.60	16	40	60	R 40.83.200	40	83	200
R 20.50.70	20	50	70	R 40.83.320	40	83	320
R 20.52.160	20	52	160	R 50.98.135	50	98	135
R 25.58.80	25	58	80	R 50.98.220	50	98	220
R 25.58.200	25	58	200	R 50.98.400	50	98	400
R 30.68.100	30	68	100	R 60.123.150	60	123	150
R 30.68.150	30	68	150	R 60.123.250	60	123	250
R 30.70.200	30	70	200	R 60.123.480	60	123	480
R 30.68.240	30	68	240	R 80.158....	80	158	...*
R 40.83.120	40	83	120	R 80.158.500	80	158	500
R 40.83.150	40	83	150				

* Länge l₂ nach Kundenwunsch

* Length l₂ on request

* Longueur l₂ à la demande du client

Werkzeughalter vorgearbeitet in vergüteter Ausführung mit 900 N/mm²
Bestell-Nr. wie oben, jedoch an Stelle R = V, z. B. V 16.40.60

1

Vierkant-Queraufnahme

Turning Tool

RADIAL-Porte outil carré

DIN 69 880 Teil 3
Form B1 rechts,
kurz

VDI 3425 Bl. 2
Form 3.1

DIN 69 880 Part 3
Form B1 right hand,
short

VDI 3425 Sheet 2
Form 3.1

DIN 69 880 Partie 3
Forme B1 droite,
court

VDI 3425 page 2
Forme 3.1

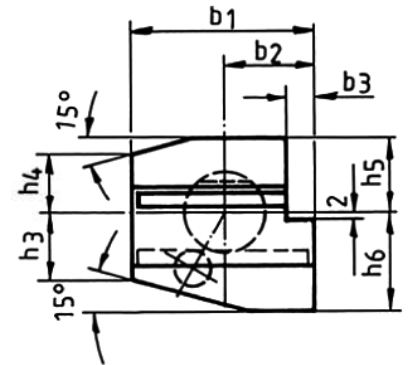
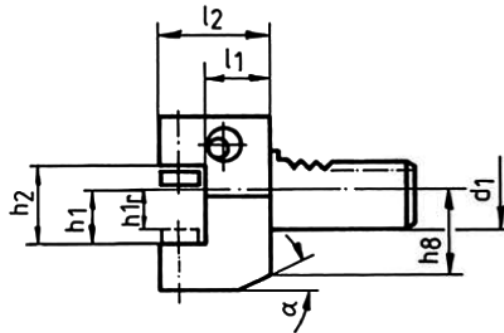
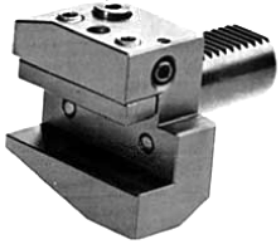

Nr.	d ₁	b ₁	b ₂	b ₃	h ₁ /h _{1r}	h ₂	h ₃	h ₄	h ₅	h ₆	h ₈	l ₁ ^{+0,5}	l ₂	α
5.1612	16	42	23	5	12	17	15	15	20	22	19	13	24	30°
5.1612.1	16	42	23	5	12	17	15	15	20	22	19	23	34	30°
5.2016/12	20	55	30	7	16/12	22	19	19	25	30	23	16	30	30°
5.2016/12.1	20	55	30	7	16/12	22	19	19	25	30	23	26	40	30°
5.2516/12	25	55	30	7	16/12	22	22,5	22,5	25	30	25	16	30	30°
5.2516/12.1	25	55	30	7	16/12	22	22,5	22,5	25	30	25	26	40	30°
5.3020/16	30	70	35	10	20/16	29	26	22	28	38	30	22	40	25°
5.3020/16.1	30	70	35	10	20/16	29	26	22	28	38	30	42	60	25°
5.4025/20	40	85	42,5	12,5	25/20	34	35	30	32,5	48		22	44	
5.5032/25	50	100	50	16	32/25	41	42	35	35	60		30	55	
5.6032/25	60	125	62,5	16	32/25	41	46	42,5	42,5	62,5		30	60	
5.8040/32	80	160	80	20	40/32	53	60	55	55	80		40	75	

Vierkant-Queraufnahme

Turning Tool

RADIAL-Porte outil carré

DIN 69 880 Teil 3
Form B2 links
kurz

VDI 3425 Bl. 2
Form 3.4

DIN 69 880 Part 3
Form B2 left hand
short

VDI 3425 Sheet 2
Form 3.4

DIN 69 880 Partie 3
Forme B2 gauche
court

VDI 3425 page 2
Forme 3.4

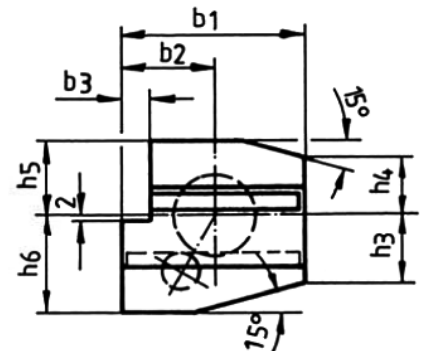
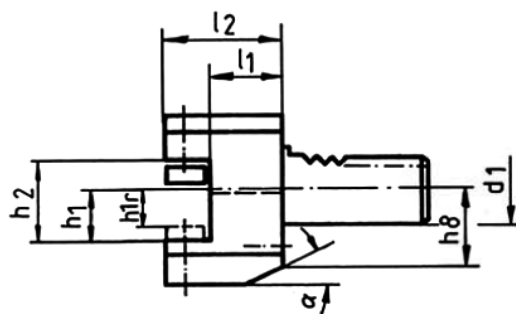

Nr.	d ₁	b ₁	b ₂	b ₃	h ₁ /h _{1r}	h ₂	h ₃	h ₄	h ₅	h ₆	h ₈	l ₁ ^{+0,5}	l ₂	α
8.1612	16	42	23	5	12	17	15	15	20	22	19	13	24	30°
8.1612.1	16	42	23	5	12	17	15	15	20	22	19	23	34	30°
8.2016/12	20	55	30	7	16/12	22	19	19	25	30	23	16	30	30°
8.2016/12.1	20	55	30	7	16/12	22	19	19	25	30	23	26	40	30°
8.2516/12	25	55	30	7	16/12	22	22,5	22,5	25	30	25	16	30	30°
8.2516/12.1	25	55	30	7	16/12	22	22,5	22,5	25	30	25	26	40	30°
8.3020/16	30	70	35	10	20/16	29	26	22	28	38	30	22	40	25°
8.3020/16.1	30	70	35	10	20/16	29	26	22	28	38	30	42	60	25°
8.4025/20	40	85	42,5	12,5	25/20	34	35	30	32,5	48		22	44	
8.5032/25	50	100	50	16	32/25	41	42	35	35	60		30	55	
8.6032/25	60	125	62,5	16	32/25	41	46	42,5	42,5	62,5		30	60	
8.8040/32	80	160	80	20	40/32	53	60	55	55	80		40	75	

Vierkant-Queraufnahme Überkopf

DIN 69 880 Teil 3
Form B3 rechts,
kurz

VDI 3425 Bl. 2
Form 3.2

Turning Tool Overhead

DIN 69 880 Part 3
Form B3 right hand,
short

VDI 3425 Sheet 2
Form 3.2

RADIAL-Porte outil carré inversé

DIN 69 880 Partie 3
Forme B3 droite,
court

VDI 3425 page 2
Forme 3.2

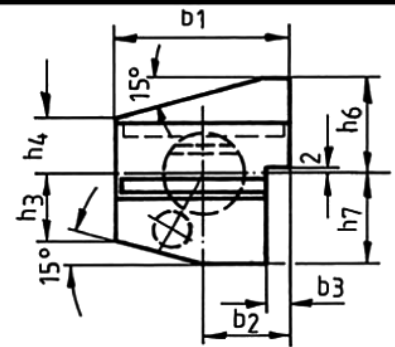
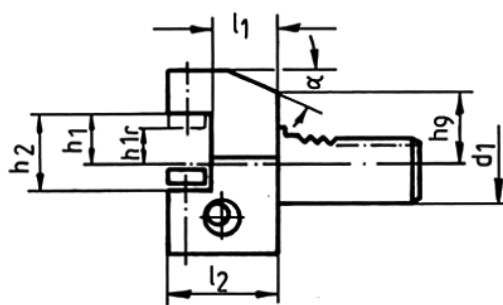

Nr.	d ₁	b ₁	b ₂	b ₃	h ₁ /h _{1r}	h ₂	h ₃	h ₄	h ₆	h ₇	h ₉	l ₁ ^{+0,5}	l ₂	α
6.1612	16	42	23	5	12	17	15	15	22	20	19	13	24	30°
6.1612.1	16	42	23	5	12	17	15	15	22	20	19	23	34	30°
6.2016/12	20	55	30	7	16/12	22	19	19	30	25	23	16	30	30°
6.2016/12.1	20	55	30	7	16/12	22	19	19	30	25	23	26	40	30°
6.2516/12	25	55	30	7	16/12	22	22,5	22,5	30	25	25	16	30	30°
6.2516/12.1	25	55	30	7	16/12	22	22,5	22,5	30	25	25	26	40	30°
6.3020/16	30	70	35	10	20/16	29	26	22	38	35	28	22	40	25°
6.3020/16.1	30	70	35	10	20/16	29	26	22	38	35	28	42	60	25°
6.4025/20	40	85	42,5	12,5	25/20	34	35	30	48	42,5		22	44	
6.5032/25	50	100	50	16	32/25	41	42	35	60	50		30	55	
6.6032/25	60	125	62,5	16	32/25	41	46	42,5	62,5	62,5		30	60	
6.8040/32	80	160	80	20	40/32	53	60	55	80	80		40	75	

Vierkant-Queraufnahme Überkopf

DIN 69 880 Teil 3
Form B4 links,
kurz

VDI 3425 Bl. 2
Form 3.3

Turning Tool Overhead

DIN 69 880 Part 3
Form B4 left hand,
short

VDI 3425 Sheet 2
Form 3.3

RADIAL-Porte outil carré inversé

DIN 69 880 Partie 3
Forme B4 gauche,
court

VDI 3425 page 2
Forme 3.3

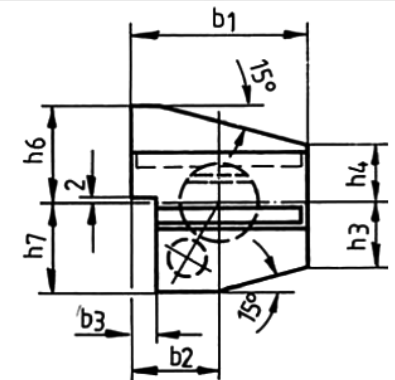
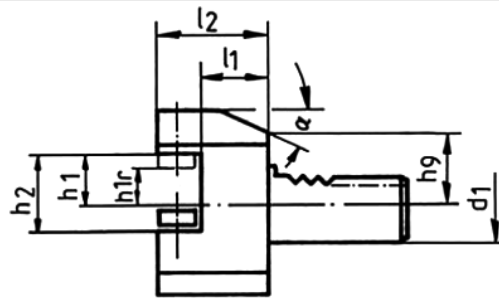

Nr.	d ₁	b ₁	b ₂	b ₃	h ₁ /h _{1r}	h ₂	h ₃	h ₄	h ₆	h ₇	h ₉	l ₁ ^{+0,5}	l ₂	α
7.1612	16	42	23	5	12	17	15	15	22	20	19	13	24	30°
7.1612.1	16	42	23	5	12	17	15	15	22	20	19	23	34	30°
7.2016/12	20	55	30	7	16/12	22	19	19	30	25	23	16	30	30°
7.2016/12.1	20	55	30	7	16/12	22	19	19	30	25	23	26	40	30°
7.2516/12	25	55	30	7	16/12	22	22,5	22,5	30	25	25	16	30	30°
7.2516/12.1	25	55	30	7	16/12	22	22,5	22,5	30	25	25	26	40	30°
7.3020/16	30	70	35	10	20/16	29	26	22	38	35	28	22	40	25°
7.3020/16.1	30	70	35	10	20/16	29	26	22	38	35	28	42	60	25°
7.4025/20	40	85	42,5	12,5	25/20	34	35	30	48	42,5		22	44	
7.5032/25	50	100	50	16	32/25	41	42	35	60	50		30	55	
7.6032/25	60	125	62,5	16	32/25	41	46	42,5	62,5	62,5		30	60	
7.8040/32	80	160	80	20	40/32	53	60	55	80	80		40	75	

1

Vierkant-Queraufnahme

Turning Tool

RADIAL-Porte outil carré

DIN 69 880 Teil 3
Form B5 rechts
lang

VDI 3425 Bl. 2
Form 5.1

DIN 69 880 Part 3
Form B5 right hand
long

VDI 3425 Sheet 2
Form 5.1

DIN 69 880 Partie 3
Forme B5 droite
long

VDI 3425 page 2
Forme 5.1

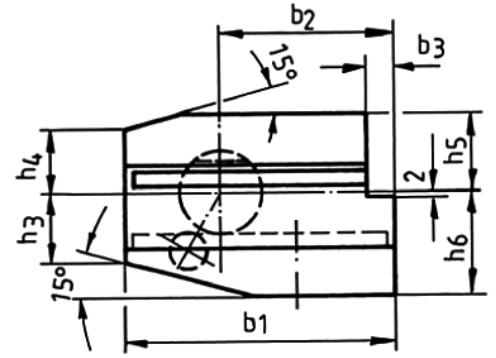
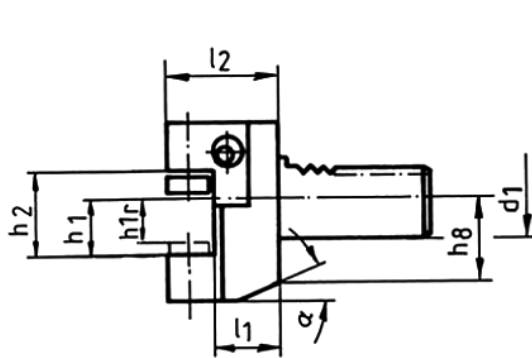

Nr.	d ₁	b ₁	b ₂	b ₃	h ₁ /h _{1r}	h ₂	h ₃	h ₄	h ₅	h ₆	h ₆	l ₁ ^{+0.5}	l ₂	α
11.1612	16	58	39	5	12	17	15	15	20	22	19	13	24	30°
11.1612.1	16	58	39	5	12	17	15	15	20	22	19	23	34	30°
11.2016/12	20	75	50	7	16/12	22	19	19	25	30	23	16	30	30°
11.2016/12.1	20	75	50	7	16/12	22	19	19	25	30	23	26	40	30°
11.2516/12	25	75	50	7	16/12	22	22,5	22,5	25	30	25	16	30	30°
11.2516/12.1	25	75	50	7	16/12	22	22,5	22,5	25	30	25	26	40	30°
11.3020/16	30	100	65	10	20/16	29	26	22	28	38	30	22	40	25°
11.3020/16.1	30	100	65	10	20/16	29	26	22	28	38	30	42	60	25°
11.4025/20	40	118	75,5	12,5	25/20	34	35	30	32,5	48		22	44	
11.5032/25	50	130	80	16	32/25	41	42	35	35	60		30	55	
11.6032/25	60	145	82,5	16	32/25	41	46	42,5	42,5	62,5		30	60	
11.8040/32	80	190	110	20	40/32	53	60	55	55	80		40	75	

Vierkant-Queraufnahme

Turning Tool

RADIAL-Porte outil carré

DIN 69 880 Teil 3
Form B6 links
lang

VDI 3425 Bl. 2
Form 5.4

DIN 69 880 Part 3
Form B6 left hand
long

VDI 3425 Sheet 2
Form 5.4

DIN 69 880 Partie 3
Forme B6 gauche
long

VDI 3425 page 2
Forme 5.4

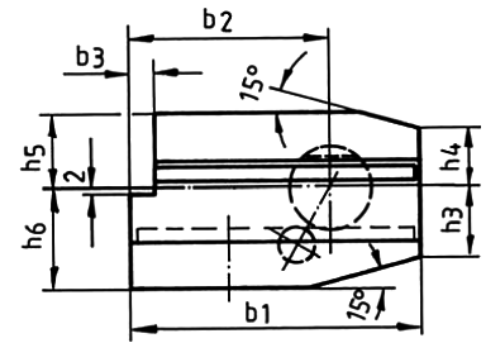
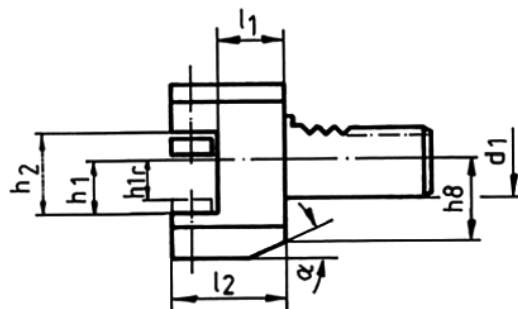

Nr.	d ₁	b ₁	b ₂	b ₃	h ₁ /h _{1r}	h ₂	h ₃	h ₄	h ₅	h ₆	h ₆	l ₁ ^{+0.5}	l ₂	α
14.1612	16	58	39	5	12	17	15	15	20	22	19	13	24	30°
14.1612.1	16	58	39	5	12	17	15	15	20	22	19	23	34	30°
14.2016/12	20	75	50	7	16/12	22	19	19	25	30	23	16	30	30°
14.2016/12.1	20	75	50	7	16/12	22	19	19	25	30	23	26	40	30°
14.2516/12	25	75	50	7	16/12	22	22,5	22,5	25	30	25	16	30	30°
14.2516/12.1	25	75	50	7	16/12	22	22,5	22,5	25	30	25	26	40	30°
14.3020/16	30	100	65	10	20/16	29	26	22	28	38	30	22	40	25°
14.3020/16.1	30	100	65	10	20/16	29	26	22	28	38	30	42	60	25°
14.4025/20	40	118	75,5	12,5	25/20	34	35	30	32,5	48		22	44	
14.5032/25	50	130	80	16	32/25	41	42	35	35	60		30	55	
14.6032/25	60	145	82,5	16	32/25	41	46	42,5	42,5	62,5		30	60	
14.8040/32	80	190	110	20	40/32	53	60	55	55	80		40	75	

**Vierkant-Queraufnahme
Überkopf**

DIN 69 880 Teil 3
Form B7 rechts
lang

VDI 3425 Bl. 2
Form 5.2

**Turning Tool
Overhead**

DIN 69 880 Part 3
Form B7 right hand
long

VDI 3425 Sheet 2
Form 5.2

**RADIAL-Porte outil carré
inversé**

DIN 69 880 Partie 3
Forme B7 droite
long

VDI 3425 page 2
Forme 5.2

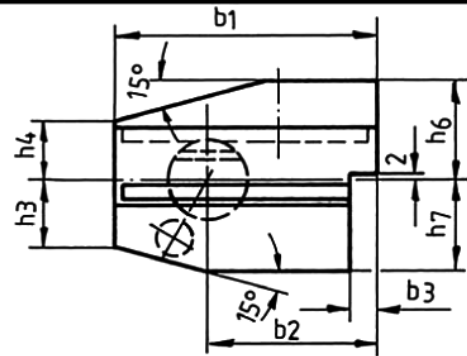
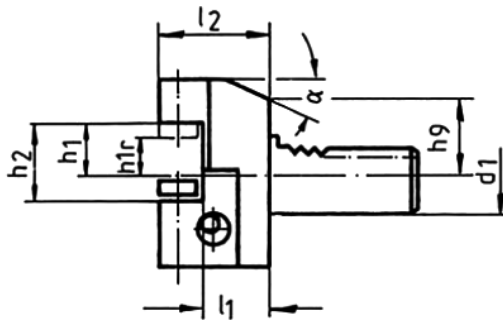

Nr.	d ₁	b ₁	b ₂	b ₃	h ₁ /h _{1r}	h ₂	h ₃	h ₄	h ₆	h ₇	h ₉	l ₁ ^{+0,5}	l ₂	α
12.1612	16	58	39	5	12	17	15	15	22	20	19	13	24	30°
12.1612.1	16	58	39	5	12	17	15	15	22	20	19	23	34	30°
12.2016/12	20	75	50	7	16/12	22	19	19	30	25	23	16	30	30°
12.2016/12.1	20	75	50	7	16/12	22	19	19	30	25	23	26	40	30°
12.2516/12	25	75	50	7	16/12	22	22,5	22,5	30	25	25	16	30	30°
12.2516/12.1	25	75	50	7	16/12	22	22,5	22,5	30	25	25	26	40	30°
12.3020/16	30	100	65	10	20/16	29	26	22	38	35	28	22	40	25°
12.3020/16.1	30	100	65	10	20/16	29	26	22	38	35	28	42	60	25°
12.4025/20	40	118	75,5	12,5	25/20	34	35	30	48	42,5		22	44	
12.5032/25	50	130	80	16	32/25	41	42	35	60	50		30	55	
12.6032/25	60	145	82,5	16	32/25	41	46	42,5	62,5	62,5		30	60	
12.8040/32	80	190	110	20	40/32	53	50	55	80	80		40	75	

**Vierkant-Queraufnahme
Überkopf**

DIN 69 880 Teil 3
Form B8 links
lang

VDI 3425 Bl. 2
Form 5.3

**Turning Tool
Overhead**

DIN 69 880 Part 3
Form B8 left hand
long

VDI 3425 Sheet 2
Form 5.3

**RADIAL-Porte outil carré
inversé**

DIN 69 880 Partie 3
Forme B8 gauche
long

VDI 3425 page 2
Forme 5.3

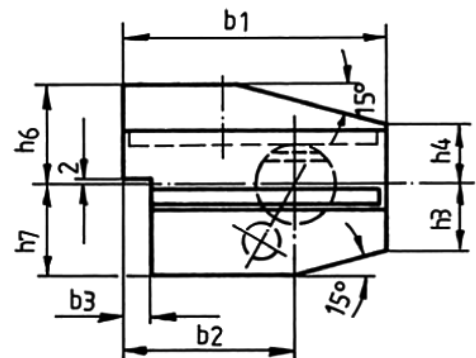
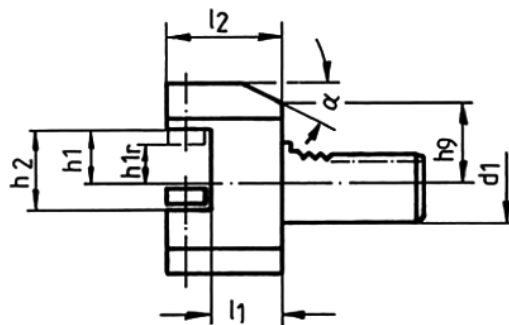

Nr.	d ₁	b ₁	b ₂	b ₃	h ₁ /h _{1r}	h ₂	h ₃	h ₄	h ₆	h ₇	h ₉	l ₁ ^{+0,5}	l ₂	α
13.1612	16	58	39	5	12	17	15	15	22	20	19	13	24	30°
13.1612.1	16	58	39	5	12	17	15	15	22	20	19	23	34	30°
13.2016/12	20	75	50	7	16/12	22	19	19	30	25	23	16	30	30°
13.2016/12.1	20	75	50	7	16/12	22	19	19	30	25	23	26	40	30°
13.2516/12	25	75	50	7	16/12	22	22,5	22,5	30	25	25	16	30	30°
13.2516/12.1	25	75	50	7	16/12	22	22,5	22,5	30	25	25	26	40	30°
13.3020/16	30	100	65	10	20/16	29	26	22	38	35	28	22	40	25°
13.3020/16.1	30	100	65	10	20/16	29	26	22	38	35	28	42	60	25°
13.4025/20	40	118	75,5	12,5	25/20	34	35	30	48	42,5		22	44	
13.5032/25	50	130	80	16	32/25	41	42	35	60	50		30	55	
13.6032/25	60	145	82,5	16	32/25	41	46	42,5	62,5	62,5		30	60	
13.8040/32	80	190	110	20	40/32	53	60	55	80	80		40	75	

Vierkant-Längsaufnahme

Turning Toolholder for Square Tool

AXIAL-Porte outil carré

DIN 69 880 Teil 4
Form C1 rechts

VDI 3425 Bl. 2
Form 1.1

DIN 69 880 Part 4
Form C1 right hand

VDI 3425 Sheet 2
Form 1.1

DIN 69 880 Partie 4
Forme C1 droite

VDI 3425 page 2
Forme 1.1

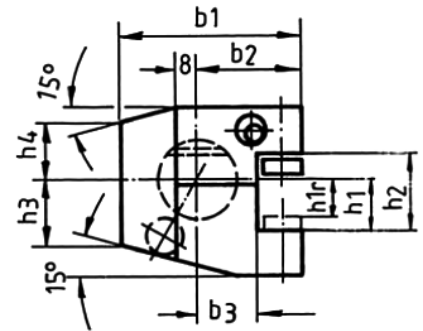
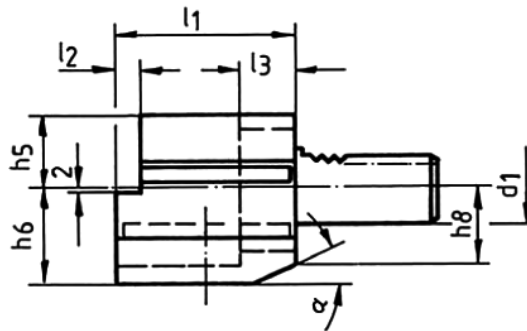
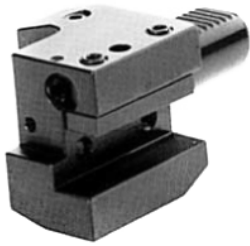

Nr.	d ₁	b ₁	b ₂	b ₃ ^{+0,5}	h ₁ /h _{1r}	h ₂	h ₃	h ₄	h ₅	h ₆	h ₈	l ₁	l ₂	l ₃	α
1.1612	16	43	24	13	12	17	15	15	20	22	19	44	5	20	30°
1.2016/12	20	52	27	13	16/12	22	19	19	25	30	23	55	7	30	30°
1.2016/12.1	20	65	40	26	16/12	22	19	19	25	30	23	50		30	30°
1.2516/12	25	58	33	19	16/12	22	22,5	22,5	25	30	25	55	7	20	30°
1.3020/16	30	70	35	17	20/16	29	26	22	28	38	30	70	10	30	25°
1.4025/20	40	85	42,5	20,5	25/20	34	35	30	32,5	48		85	12,5	30	
1.5032/25	50	100	50	25,5	32/25	41	42	35	35	60		100	16	40	
1.6032/25	60	125	62,5	32,5	32/25	41	46	42,5	42,5	62,5		125	16	40	
1.8040/32	80	160	80	41	40/32	53	60	55	55	80		160	20	40	

Vierkant-Längsaufnahme

Turning Toolholder for Square Tool

AXIAL-Porte outil carré

DIN 69 880 Teil 4
Form C2 links

VDI 3425 Bl. 2
Form 1.4

DIN 69 880 Part 4
Form C2 left hand

VDI 3425 Sheet 2
Form 1.4

DIN 69 880 Partie 4
Forme C2 gauche

VDI 3425 page 2
Forme 1.4

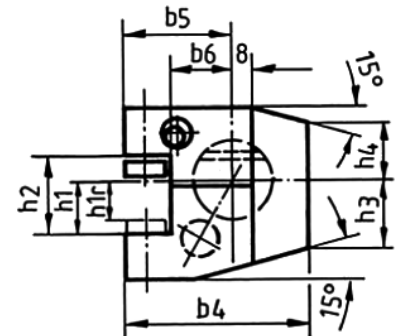
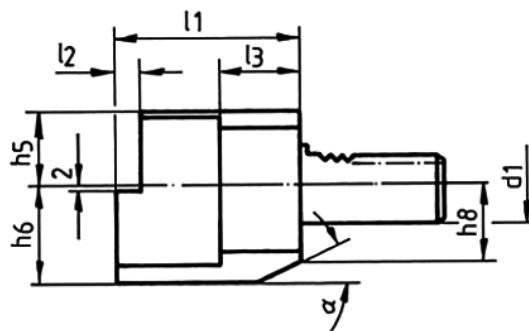

Nr.	d ₁	b ₄	b ₅	b ₆ ^{+0,5}	h ₁ /h _{1r}	h ₂	h ₃	h ₄	h ₅	h ₆	h ₈	l ₁	l ₂	l ₃	α
4.1612	16	43	24	13	12	17	15	15	20	22	19	44	5	20	30°
4.2016/12	20	65	40	26	16/12	22	19	19	25	30	23	50		30	30°
4.2516/12	25	58	33	19	16/12	22	22,5	22,5	25	30	25	55	7	20	30°
4.3020/16	30	76	41	23	20/16	29	26	22	28	38	30	70	10	30	25°
4.4025/20	40	90	47,5	25,5	25/20	34	35	30	32,5	48		85	12,5	30	
4.5032/25	50	105	55	30,5	32/25	41	42	35	35	60		100	16	40	
4.6032/25	60	125	62,5	32,5	32/25	41	46	42,5	42,5	62,5		125	16	40	
4.8040/32	80	160	80	41	40/32	53	60	55	55	80		160	20	40	

**Vierkant-Längsaufnahme
Überkopf**

DIN 69 880 Teil 4
Form C3 rechts

VDI 3425 Bl. 2
Form 1.2

**Turning Toolholder
for Square Tool, Overhead**

DIN 69 880 Part 4
Form C3 right hand

VDI 3425 Sheet 2
Form 1.2

**AXIAL-Porte outil carré
inversé**

DIN 69 880 Partie 4
Forme C3 droite

VDI 3425 page 2
Forme 1.2

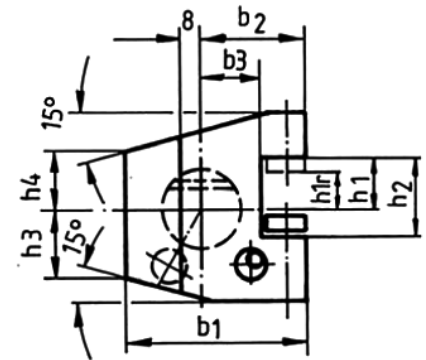
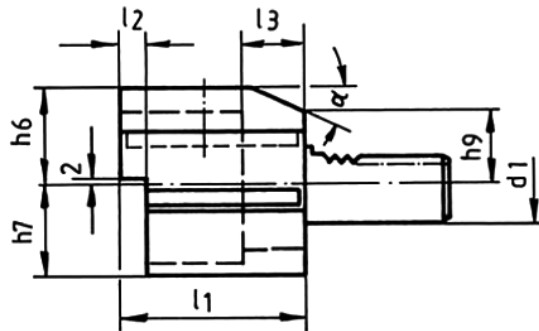

Nr.	d ₁	b ₁	b ₂	b ₃ ^{+0.5}	h ₁ /h _{1r}	h ₂	h ₃	h ₄	h ₆	h ₇	h ₉	l ₁	l ₂	l ₃	α
2.1612	16	43	24	13	12	17	15	15	22	20		44	5	20	30°
2.2016/12	20	52	27	13	16/12	22	19	19	30	25	23	55	7	30	30°
2.2016/12.1	20	65	40	26	16/12	22	19	19	30	25	23	50		20	30°
2.2516/12	25	58	33	19	16/12	22	22,5	22,5	30	25	25	55	7	30	30°
2.3020/16	30	70	35	17	20/16	29	26	22	38	35	28	70	10	30	25°
2.4025/20	40	85	42,5	20,5	25/20	34	35	30	48	42,5		85	12,5	30	
2.5032/25	50	100	50	25,5	32/25	41	42	35	60	50		100	16	40	
2.6032/25	60	125	62,5	32,5	32/25	41	46	42,5	62,5	62,5		125	16	40	
2.8040/32	80	160	80	41	40/32	53	50	55	80	80		160	20	40	

**Vierkant-Längsaufnahme
Überkopf**

DIN 69 880 Teil 4
Form C4 links

VDI 3425 Bl. 2
Form 1.3

**Turning Toolholder
for Square Tool, Overhead**

DIN 69 880 Part 4
Form C4 left hand

VDI 3425 Sheet 2
Form 1.3

**AXIAL-Porte outil carré
inversé**

DIN 69 880 Partie 4
Forme C4 gauche

VDI 3425 page 2
Forme 1.3

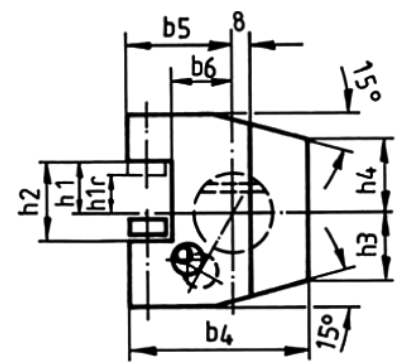
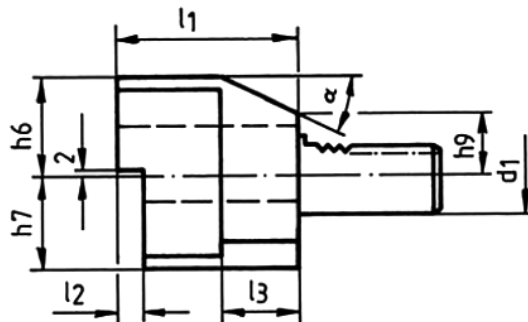

Nr.	d ₁	b ₄	b ₅	b ₆ ^{+0.5}	h ₁ /h _{1r}	h ₂	h ₃	h ₄	h ₆	h ₇	h ₉	l ₁	l ₂	l ₃	a
3.1612	16	43	24	13	12	17	15	15	22	20		44	5	20	30°
3.2016/12	20	65	40	26	16/12	22	19	19	30	25	23	50		30	30°
3.2516/12	25	58	33	19	16/12	22	22,5	22,5	30	25	25	55	7	20	30°
3.3020/16	30	76	41	23	20/16	29	26	22	38	35	28	70	10	30	25°
3.4025/20	40	90	47,5	25,5	25/20	34	35	30	48	42,5		85	12,5	30	
3.5032/25	50	105	55	30,5	32/25	41	42	35	60	50		100	16	40	
3.6032/25	60	125	62,5	32,5	32/25	41	46	42,5	62,5	62,5		125	16	40	
3.8040/32	80	160	80	41	40/32	53	60	55	80	80		160	20	40	

1

Vierkant-Mehrfach-aufnahme

DIN 69 880 Teil 5
Form D1

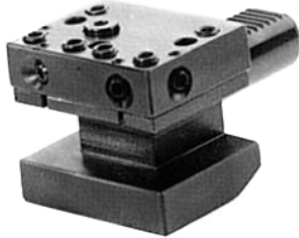

Multi Purpose Square Toolholder

DIN 69 880 Part 5
Form D1

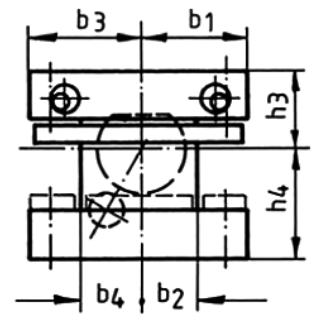
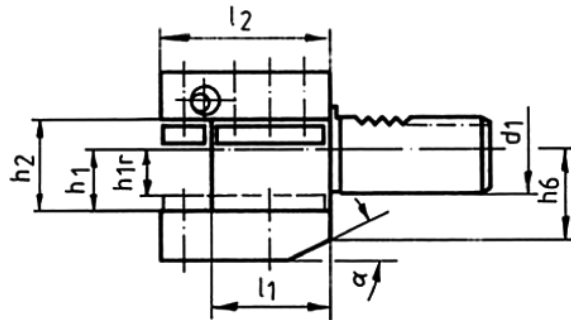

Nr.	d ₁	h ₁ /h _{1r}	b ₁	b ₂ ^{+0,5}	b ₃	b ₄ ^{+0,5}	h ₂	h ₃	h ₄	h ₆	l ₁ ^{+0,5}	l ₂	α
15.2516/12	25	16/12	33	19	33	19	22	25	30	25	34	48	30°
15.3020/16	30	20/16	35	17	41	23	29	28	38	30	42	60	25°
15.4025/20	40	25/20	42,5	20,5	47,5	25,5	34	32,5	48		50	72	
15.5032/25	50	32/25	50	25,5	55	30,5	41	35	60		60	85	
15.6032/25	60	32/25	57,5	32,5	57,5	32,5	41	42,5	62,5		85	110	
15.8040/32	80	40/32	76	41	76	41	53	55	80		105	140	

Vierkant-Mehrfach-aufnahme Überkopf

DIN 69 880 Teil 5
Form D2

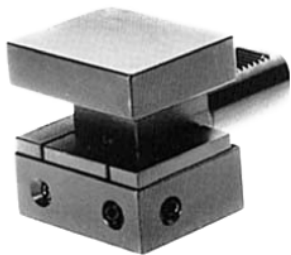

Multi Purpose Square Toolholder overhead

DIN 69 880 Part 5
Form D2

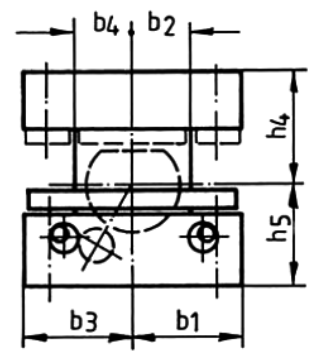
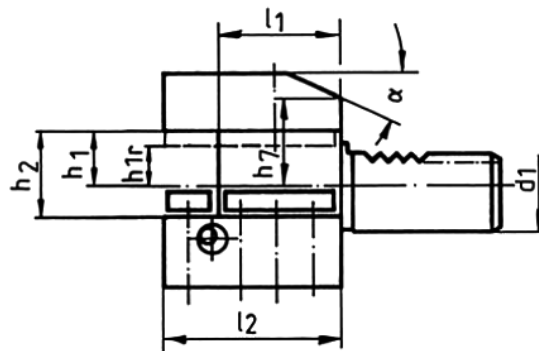

Nr.	d ₁	h ₁ /h _{1r}	b ₁	b ₂ ^{+0,5}	b ₃	b ₄ ^{+0,5}	h ₂	h ₄	h ₅	h ₇	l ₁ ^{+0,5}	l ₂	α
16.2516/12	25	16/12	33	19	33	19	22	30	25	25	34	48	30°
16.3020/16	30	20/16	35	17	41	23	29	38	35	28	42	60	25°
16.4025/20	40	25/20	42,5	20,5	47,5	25,5	34	48	42,5		50	72	
16.5032/25	50	32/25	50	25,5	55	30,5	41	60	50		60	85	
16.6032/25	60	32/25	57,5	32,5	57,5	32,5	41	62,5	62,5		85	110	
16.8040/32	80	40/32	76	41	76	41	53	80	80		105	140	

Axial-Werkzeughalter

DIN 69 880 VDI 3425 Bl. 2

Axial Toolholder

DIN 69 880 VDI 3425 Sheet 2

AXIAL-Porte outil

DIN 69 880 VDI 3425 page 2

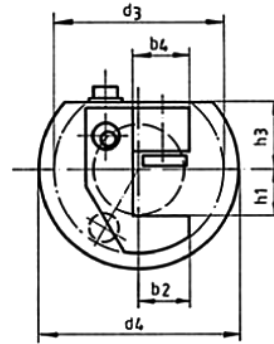
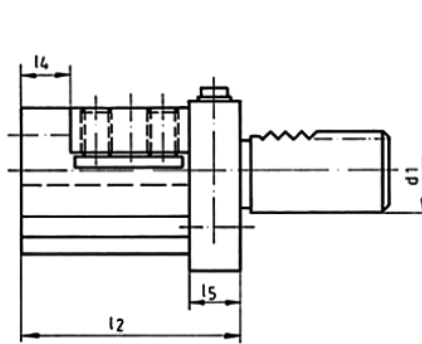

R = Rechte Ausführung (wie gezeichnet)
L = Linke Ausführung (spiegelbildlich)

R = right side (as shown)
L = leftside (mirror image)

R = Exécution droite (dessin ci dessus)
L = Exécution gauche (dessin à inverser)

Nr.	d ₁	d ₃	d ₄	h ₁	h ₃	b ₂	b ₄	l ₂	l ₄	l ₅
23.3016R	30	68	68	16	28	16	16	70	16	14
23.3016L	30	68	68	16	28	16	16	70	16	14
23.4020R	40	83	83	20	32,5	20	20	100	20	16
23.4020L	40	83	83	20	32,5	20	20	100	20	16
23.5025R	50	85	98	25	35	25	25	120	25	28
23.5025L	50	85	98	25	35	25	25	120	25	28
23.6025R	60	110	123	25	42,5	20	26	120	15	28
23.6025L	60	110	123	25	42,5	20	26	120	15	28

Radial-Axial-Werkzeughalter

DIN 69 880 VDI 3425 Bl. 2

Radial-Axial Toolholder

DIN 69 880 VDI 3425 Sheet 2

RADIAL-AXIAL-Porte outil

DIN 69 880 VDI 3425 page 2

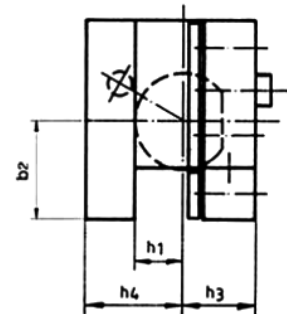
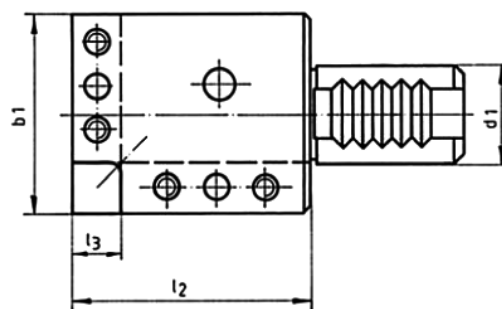

R = Rechte Ausführung (wie gezeichnet)
L = Linke Ausführung (spiegelbildlich)

R = right side (as shown)
L = leftside (mirror image)

R = Exécution droite (dessin ci dessus)
L = Exécution gauche (dessin à inverser)

Nr.	Rechts right/droit	Links left/gauche	d ₁	h ₁	l ₁	l ₂	l ₃	b ₁	b ₂	h ₃	h ₄
26.3020/16R	26.3020/16L	30	20/16	55	70	18	74	39	28	38	
26.4025/20R	26.4025/20L	40	25/20	63	100	22	90	47,5	32,5	48	
26.5032/25R	26.5032/25L	50	32/25	78	120	25	107	56	35	60	
26.6032/25R	26.6032/25L	60	32/25	94	135	28	125	62,5	42,5	62,5	
26.8040/32R	26.8040/32L	80	40/32	124	140	30	160	80	55	80	

1

Grundhalter für Queraufnahme

rechts
DIN 69 880

VDI 3425 Bl. 2

Basic Toolholder for Diagonal Adaptor

right hand
DIN 69 880

VDI 3425 Sheet 2

RADIAL-Porte outil de base

droite
DIN 69 880

VDI 3425 page 2

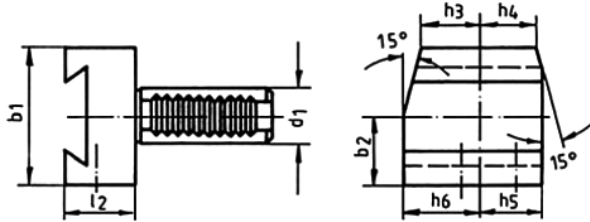
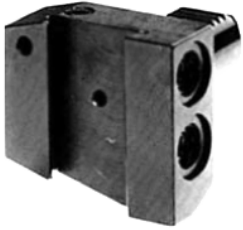

Nr.	d ₁	b ₁	b ₂	h ₃	h ₄	h ₅	h ₆	l ₂
32.16.1	16	42	23	15	15	20	22	24
32.20.1	20	55	30	19	19	25	30	24
32.25.1	25	55	30	22,5	22,5	25	30	24
32.30.1	30	70	35	26	22	28	38	28
32.40.1	40	85	42,5	35	30	32,5	48	29
32.50.1	50	100	50	42	35	35	60	29

Wechselhalter mit Queraufnahme

rechts, höhenverstellbar

Infeed Toolholder with Diagonal Adaptor

right hand, height adjustable

RADIAL-Support interchangeable

droite, hauteur réglable

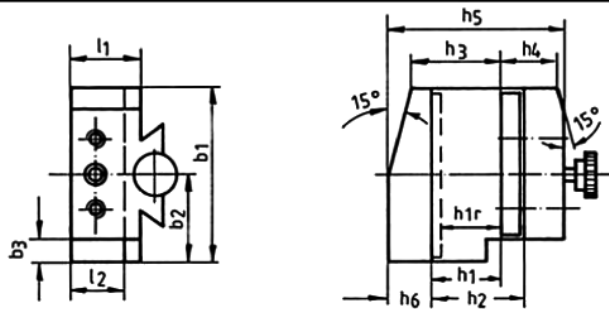

Nr.	b ₁	b ₂	b ₃	h ₁ /h _{1r}	h ₂	h ₃	h ₄	h ₅	h ₆	l ₁	l ₂
32.111	42	23	5	12	17	14	14	40	9	19	11
32.211	55	30	7	16/12	22	18	18	53	13	25	12
32.311	70	35	10	20/16	29	25	21	63	17	30	18
32.411	85	42,5	12,5	25/20	34	34	29	78	22	34	22
32.511	100	50	16	32/25	41	41	34	93	27	36	25

Wechselhalter mit Queraufnahme, Überkopf

rechts, höhenverstellbar

Infeed Toolholder with Diagonal Adaptor, overhead

right hand, height adjustable

RADIAL-Support interchangeable

droite, hauteur réglable

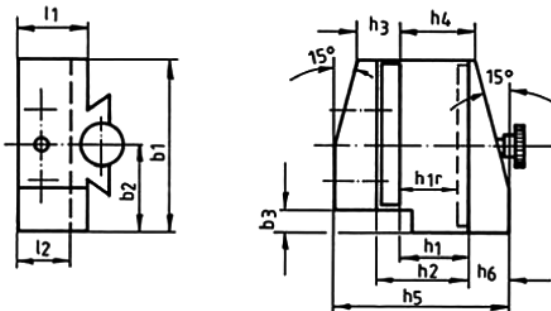

Nr.	b ₁	b ₂	b ₃	h ₁ /h _{1r}	h ₂	h ₃	h ₄	h ₅	h ₆	l ₁	l ₂
32.111ÜK	42	23	5	12	17	14	14	40	9	19	11
32.211ÜK	55	30	7	16/12	22	18	18	58	13	25	12
32.311ÜK	70	35	10	20/16	29	25,5	21,5	72	17	30	18
32.411ÜK	85	42,5	12,5	25/20	34	34	29	87	21,5	34	22
32.511ÜK	100	50	16	32/25	41	41	34	106	24	36	25

Wechselhalter für Stechwerkzeuge

rechts, höhenverstellbar



Infeed Toolholder for Fitting Tools

right hand, height adjustable

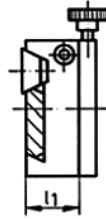

RADIAL-Support inter-changeable de tronçonnage

droite, hauteur réglable

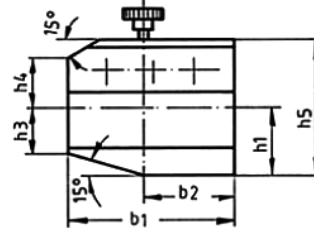

Nr.	b ₁	b ₂	h ₁	h ₃	h ₄	h ₅	l ₁
32.112	42	23	22	15	14	41	19
32.212	55	30	29	18	18	53	25
32.312	70	35	37	25	21	63	25
32.412	85	42,5	47	34	29	78	25
32.512	100	50	59	41	34	93	25

Bei Bestellung Stechhalter, Typ und Abmessung angeben
Wechselhalter 32..12 ÜK Überkopf auf Anfrage

When ordering fitting holder, please give Type and measurements
Infeed Toolholder 32..12 ÜK overhead on request

Spécifier à la commande marque et dimensions de l'outil de tronçonnage utilisé
Support interchangeable inversé 32..12 ÜK sur demande

Wechselhalter für Ausdrehwerkzeuge

rechts, höhenverstellbar



Infeed Toolholder for Turning Tools

right hand, height adjustable

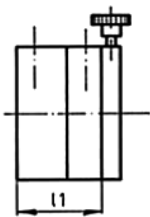

Support interchangeable

droite, hauteur réglable

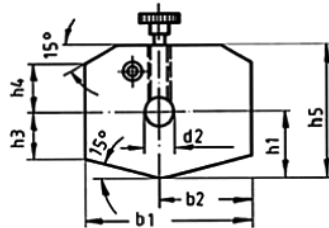

Nr.	d ₂	b ₁	b ₂	h ₁	h ₃	h ₄	h ₅	l ₁
32.113	6-10	42	23	21	14	14	40	25
32.213	8-16	55	30	29	18	18	53	32
32.313	8-25	70	35	37	25	21	63	36
32.413	8-25	85	42,5	47	34	29	78	40
32.513	8-25	100	50	59	41	34	93	40

Bei Bestellung d₂ angeben

When ordering, please give d₂

A la commande spécifier d₂

Wechselhalter für Spannzangen

rechts, höhenverstellbar



Infeed Toolholder for Collets

right hand, height adjustable

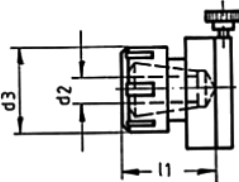

Support Pince de serrage

droite, hauteur réglable

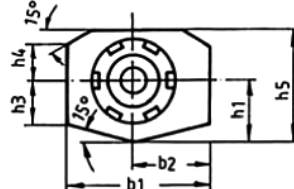

Nr.	d ₂	d ₃	b ₁	b ₂	h ₁	h ₃	h ₄	h ₅	l ₁	passende Spannzangen
32.114.01	1-10	28	42	23	21	14	14	40	41	160 426E
32.114.02	1-13	34	42	23	21	14	14	40	44	200 428E
32.114.1	1-16	42	42	23	21	14	14	40	49	250 430E
32.214.1	1-16	42	55	30	29	18	18	53	46	250 430E
32.314.1	1-16	42	70	35	37	25	21	63	46	250 430E
32.314.2	2-20	50	70	35	37	25	21	63	51	320 470E
32.414.1	1-16	42	85	42,5	47	34	29	78	46	250 430E
32.414.2	2-20	50	85	42,5	47	34	29	78	51	320 470E
32.414.3	3-26	63	85	42,5	47	34	29	78	57	400 472E
32.514.3	3-26	63	100	50	59	41	34	93	57	400 472E

Grundhalter für Queraufnahme

links
DIN 69 880

VDI 3425 Bl. 2

Basic Toolholder for Diagonal Adaptor

left hand
DIN 69 880

VDI 3425 Sheet 2

RADIAL-Porte outil de base

gauche
DIN 69 880

VDI 3425 page 2

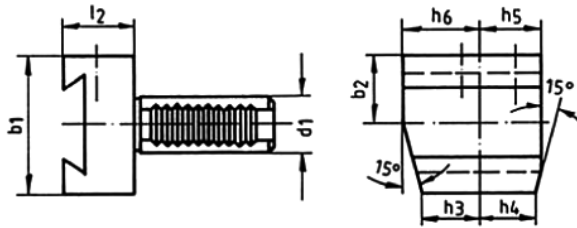

Nr.	d ₁	b ₁	b ₂	h ₃	h ₄	h ₅	h ₆	l ₂
32.16.3	16	42	23	15	15	20	22	24
32.20.3	20	55	30	19	19	25	30	24
32.25.3	25	55	30	22,5	22,5	25	30	24
32.30.3	30	70	35	26	22	28	38	28
32.40.3	40	85	42,5	35	30	32,5	48	29
32.50.3	50	100	50	42	35	35	60	29

Wechselhalter mit Queraufnahme

links, höhenverstellbar

Infeed Toolholder with Diagonal Adaptor

left hand, height adjustable

RADIAL-Support interchangeable

gauche, hauteur réglable

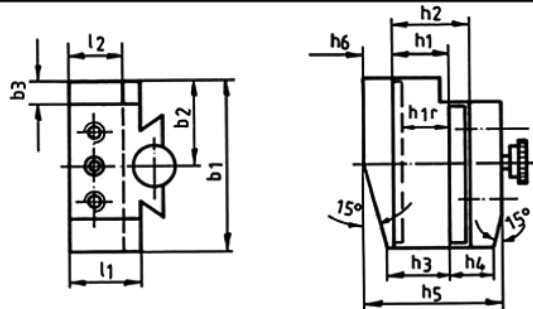

Nr.	b ₁	b ₂	b ₃	h ₁ /h _{1r}	h ₂	h ₃	h ₄	h ₅	h ₆	l ₁	l ₂
32.131	42	23	5	12	17	14	14	40	9	19	11
32.231	55	30	7	16/12	22	18	18	53	13	25	12
32.331	70	35	10	20/16	29	25	21	63	17	30	18
32.431	85	42,5	12,5	25/20	34	34	29	78	22	34	22
32.531	100	50	16	32/25	41	41	34	93	27	36	25

Wechselhalter mit Queraufnahme, Überkopf

links, höhenverstellbar

Infeed Toolholder with Diagonal Adaptor, overhead

left hand, height adjustable

RADIAL-Support interchangeable

gauche, hauteur réglable

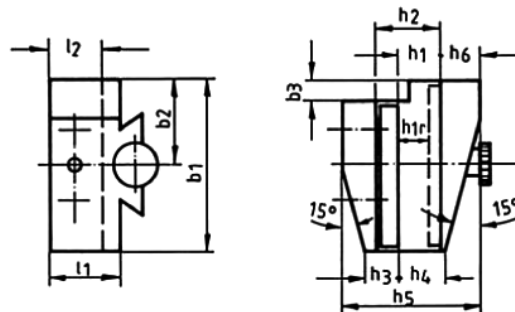

Nr.	b ₁	b ₂	b ₃	h ₁ /h _{1r}	h ₂	h ₃	h ₄	h ₅	h ₆	l ₁	l ₂
32.131ÜK	42	23	5	12	17	14	14	40	9	19	11
32.231ÜK	55	30	7	16/12	22	18	18	58	13	25	12
32.331ÜK	70	35	10	20/16	29	25,5	21,5	72	17	30	18
32.431ÜK	85	42,5	12,5	25/20	34	34	29	87	21,5	34	22
32.531ÜK	100	50	16	32/25	41	41	34	106	24	36	25

Wechselhalter für Stechwerkzeuge

links, höhenverstellbar



Infeed Toolholder for Fitting Tools

left hand, height adjustable

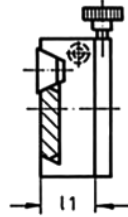

RADIAL-Support inter-changeable de tronçonnage

gauche, hauteur réglable

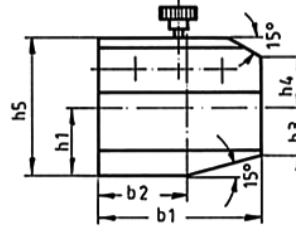

Nr.	b ₁	b ₂	h ₁	h ₃	h ₄	h ₅	l ₁
32.132	42	23	22	15	14	41	19
32.232	55	30	29	18	18	53	25
32.332	70	35	37	25	21	63	25
32.432	85	42,5	47	34	29	78	25
32.532	100	50	59	41	34	93	25

Bei Bestellung Stechhalter, Typ und Abmessung angeben

Wechselhalter 32..12 ÜK Überkopf auf Anfrage

When ordering fitting holder, please give Type and measurements

Infeed Toolholder 32..12 ÜK overhead on request

Spécifier à la commande marque et dimensions de l'outil de tronçonnage utilisé

Support interchangeable inversé 32..12 ÜK sur demande

Wechselhalter für Ausdrehwerkzeuge

links, höhenverstellbar



Infeed Toolholder for Turning Tools

left hand, height adjustable

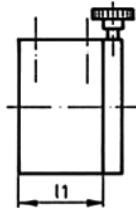

Support interchangeable

gauche, hauteur réglable

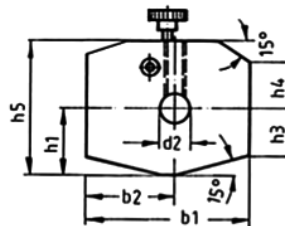

Nr.	d ₂	b ₁	b ₂	h ₁	h ₃	h ₄	h ₅	l ₁
32.113	6-10	42	23	21	14	14	40	25
32.213	8-16	55	30	29	18	18	53	32
32.313	8-25	70	35	37	25	21	63	36
32.413	8-25	85	42,5	47	34	29	78	40
32.513	8-25	100	50	59	41	34	93	40

Bei Bestellung d₂ angeben

When ordering, please give d₂

A la commande spécifier d₂

Wechselhalter für Spannzangen

links, höhenverstellbar



Infeed Toolholder for Collets

left hand, height adjustable

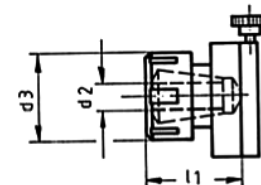

Support Pince de serrage

gauche, hauteur réglable

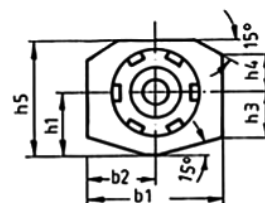

Nr.	d ₂	d ₃	b ₁	b ₂	h ₁	h ₃	h ₄	h ₅	l ₁	passende Spannzangen
32.114.01	1-10	28	42	23	21	14	14	40	41	160 426E
32.114.02	1-13	34	42	23	21	14	14	40	44	200 428E
32.114.1	1-16	42	42	23	21	14	14	40	49	250 430E
32.214.1	1-16	42	55	30	29	18	18	53	46	250 430E
32.314.1	1-16	42	70	35	37	25	21	63	46	250 430E
32.314.2	2-20	50	70	35	37	25	21	63	51	320 470E
32.414.1	1-16	42	85	42,5	47	34	29	78	46	250 430E
32.414.2	2-20	50	85	42,5	47	34	29	78	51	320 470E
32.414.3	3-26	63	85	42,5	47	34	29	78	57	400 472E
32.514.3	3-26	63	100	50	59	41	34	93	57	400 472E

Grundhalter für Längsaufnahme

rechts
DIN 69 880

VDI 3425 Bl. 2

Basic Toolholder for Axial Adaptor

right hand
DIN 69 880

VDI 3425 Sheet 2

Axial-Porte outil de base

droite
DIN 69 880

VDI 3425 page 2

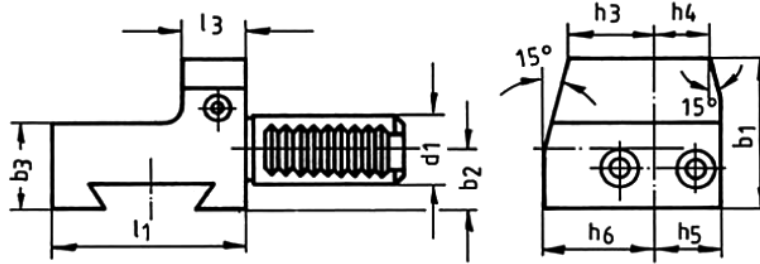

Nr.	d ₁	b ₁	b ₂	b ₃	h ₃	h ₄	h ₅	h ₆	l ₁	l ₃
32.16.2	16	35	16	24	15	15	20	22	44	21
32.20.2	20	40	16	24	19	19	25	30	55	30
32.25.2	25	41	16	24	22,5	22,5	25	30	55	30
32.30.2	30	55	20	28	26	22	28	38	70	30
32.40.2	40	70	27,5	35	35	30	32,5	48	85	30
32.50.2	50	83	33	40	42	35	35	60	100	40

Wechselhalter mit Längsaufnahme

rechts, höhenverstellbar

Infeed Toolholder with Axial Adaptor

right hand, height adjustable

Axial-Support interchangeable

droite, hauteur réglable

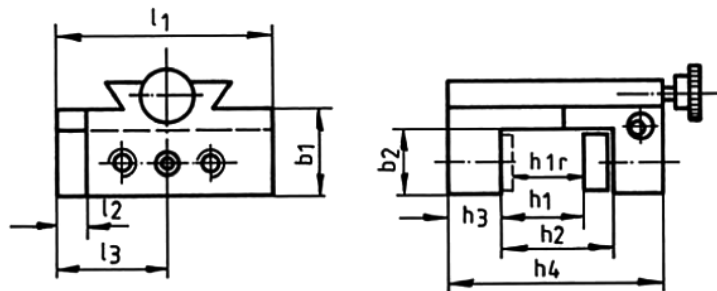

Nr.	b ₁	b ₂	h ₁ /h _{1r}	h ₂	h ₃	h ₄	l ₁	l ₂	l ₃
32.121	19	11	12	17	9	40	42	5	23
32.221	25	12	16/12	22	13	53	54	7	30
32.321	30	18	20/16	29	17	63	69	10	35
32.421	34	22	25/20	34	22	78	84	12,5	42,5
32.521	36	25	32/25	41	27	93	99	16	50

Wechselhalter mit Längsaufnahme, Überkopf

rechts, höhenverstellbar

Infeed Toolholder with Axial Adaptor, overhead

right hand, height adjustable

Axial-Support interchangeable

droite, hauteur réglable

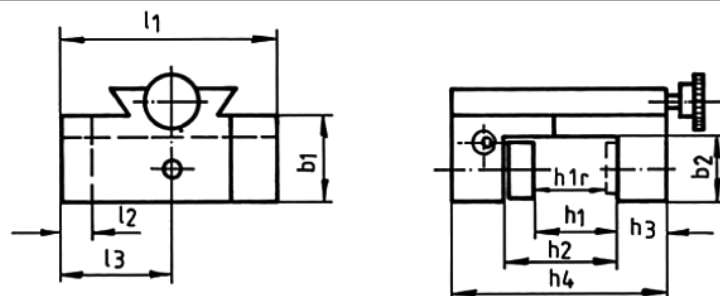

Nr.	b ₁	b ₂	h ₁ /h _{1r}	h ₂	h ₃	h ₄	l ₁	l ₂	l ₃
32.121ÜK	19	11	12	17	9	40	42	5	23
32.221ÜK	25	12	16/12	22	13	58	54	7	30
32.321ÜK	30	18	20/16	29	17	72	69	10	35
32.421ÜK	34	22	25/20	34	21,5	87	84	12,5	42,5
32.521ÜK	36	25	32/25	41	24	106	99	16	50

Grundhalter für Längsaufnahme

links
DIN 69 880

VDI 3425 Bl. 2

Basic Toolholder for Axial Adaptor

left hand
DIN 69 880

VDI 3425 Sheet 2

Axial-Porte outil de base

gauche
DIN 69 880

VDI 3425 page 2

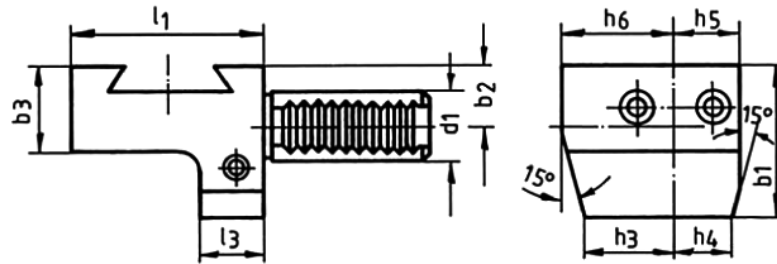

Nr.	d ₁	b ₁	b ₂	b ₃	h ₃	h ₄	h ₅	h ₆	l ₁	l ₃
32.16.4	16	37	18	24	15	15	20	22	44	21
32.20.4	20	43	18	24	19	19	25	30	55	30
32.25.4	25	43	18	24	22,5	22,5	25	30	55	30
32.30.4	30	59	24	28	26	22	28	38	70	30
32.40.4	40	70	27,5	35	35	30	32,5	48	85	30
32.50.4	50	83	33	40	42	35	35	60	100	40

Wechselhalter mit Längsaufnahme

links, höhenverstellbar

Infeed Toolholder with Axial Adaptor

left hand, height adjustable

Axial-Support interchangeable

gauche, hauteur réglable

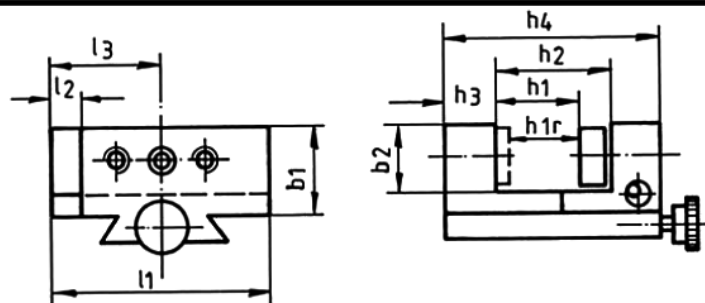

Nr.	b ₁	b ₂	h ₁ /h _{1r}	h ₂	h ₃	h ₄	l ₁	l ₂	l ₃
32.141	19	11	12	17	9	40	42	5	23
32.241	25	12	16/12	22	13	53	54	7	30
32.341	30	18	20/16	29	17	63	69	10	35
32.441	34	22	25/20	34	22	78	84	12,5	42,5
32.541	36	25	32/25	41	27	93	99	16	50

Wechselhalter mit Längsaufnahme, Überkopf

links, höhenverstellbar

Infeed Toolholder with Axial Adaptor, overhead

left hand, height adjustable

Axial-Support interchangeable

gauche, hauteur réglable

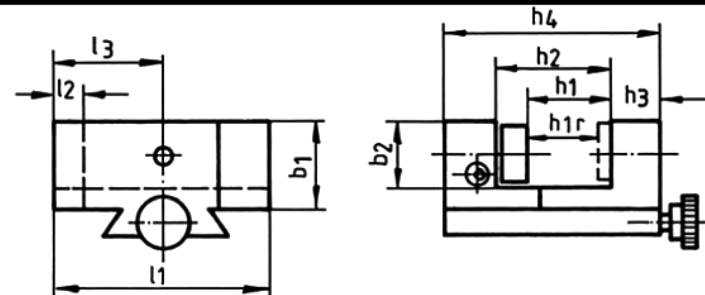

Nr.	b ₁	b ₂	h ₁ /h _{1r}	h ₂	h ₃	h ₄	l ₁	l ₂	l ₃
32.141ÜK	19	11	12	17	9	40	42	5	23
32.241ÜK	25	12	16/12	22	13	58	54	7	30
32.341ÜK	30	18	20/16	29	17	72	69	10	35
32.441ÜK	34	22	25/20	34	21,5	87	84	12,5	42,5
32.541ÜK	36	25	32/25	41	24	106	99	16	50

1

Zylinderaufnahme

DIN 69 880 Teil 6, VDI 3425 Bl. 2
Form E2 für Drehwerkzeuge
mit Zylinderschaft

Side Lock Adaptor

DIN 69 880 Part 6, VDI 3425 Sheet 2
Form E2 for turning-tools
with cylindrical shaft

Porte outil cylindrique

DIN 69 880 Partie 6, VDI 3425 page 2
Forme E2 pour outils de tour cylindrique

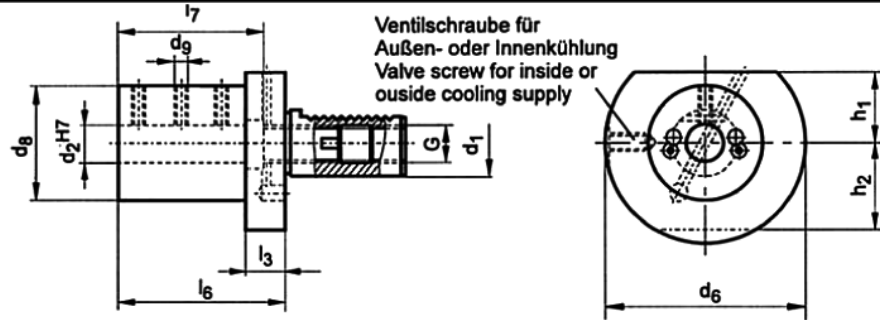

Nr./No.	d ₁	d ₂	d ₃	d ₄	d ₅	h ₁	h ₂	l ₃	l ₆	l ₇	G
19.1606	16	6	40	32	M6	18	18	13	44	34	M8x1
19.1608	16	8	40	32	M6	18	18	13	44	34	M8x1
19.1610	16	10	40	32	M6	18	18	13	44	34	M8x1
19.1612	16	12	40	40	M8	18	18		44	34	M8x1
19.1616	16	16	40	40	M8	18	18		44	34	M8x1
19.2008	20	8	50	40	M8	23	23	18	50	41	M10x1
19.2010	20	10	50	40	M8	23	23	18	50	41	M10x1
19.2012	20	12	50	40	M8	23	23	18	50	41	M10x1
19.2016	20	16	50	40	M8	23	23	18	50	41	M10x1
19.2020	20	20	50	45	M8	23	23		50	41	M10x1
19.2025	20	25	50	45	M8	23	23		60	51	M10x1
19.2508	25	8	58	40	M8	25	25	18	50	41	M14x1,5
19.2510	25	10	58	40	M8	25	25	18	50	41	M14x1,5
19.2512	25	12	58	40	M8	25	25	18	50	41	M14x1,5
19.2516	25	16	58	40	M8	25	25	18	50	41	M14x1,5
19.2520	25	20	58	58	M8	25	25		50	41	M14x1,5
19.2525	25	25	58	58	M8	25	25		60	51	M14x1,5
19.3008	30	8	68	55	M8	28	30	22	60	51	M18x1,5
19.3010	30	10	68	55	M8	28	30	22	60	51	M18x1,5
19.3012	30	12	68	55	M8	28	30	22	60	51	M18x1,5
19.3016	30	16	68	55	M8	28	30	22	60	51	M18x1,5
19.3020	30	20	68	55	M8	28	30	22	60	51	M18x1,5
19.3025	30	25	68	55	M8	28	30	22	60	51	M18x1,5
19.3032	30	32	68	62	M8	28	30		75	61	M18x1,5
19.4008	40	8	83	55	M8	32,5		22	75	61	M22x1,5
19.4010	40	10	83	55	M8	32,5		22	75	61	M22x1,5
19.4012	40	12	83	55	M8	32,5		22	75	61	M22x1,5
19.4016	40	16	83	55	M10	32,5		22	75	61	M22x1,5
19.4020	40	20	83	55	M10	32,5		22	75	61	M22x1,5
19.4025	40	25	83	55	M10	32,5		22	75	61	M22x1,5
19.4032	40	32	83	70	M10	32,5			75	61	M22x1,5
19.4040	40	40	83	70	M10	32,5			90	76	M22x1,5
19.5012	50	12	98	62	M12	38		30	90	76	M28x1,5
19.5016	50	16	98	62	M12	35		30	90	76	M28x1,5
19.5020	50	20	98	62	M12	35		30	90	76	M28x1,5
19.5025	50	25	98	62	M12	35		30	90	76	M28x1,5
19.5032	50	32	98	62	M12	35		30	90	76	M28x1,5
19.5040	50	40	98	80	M12	35			90	76	M28x1,5
19.5050	50	50	98	80	M12	35			100	86	M28x1,5
19.6016	60	16	123	68	M12	42,5		30	90	76	M42x1,5
19.6020	60	20	123	68	M12	42,5		30	90	76	M42x1,5
19.6025	60	25	123	68	M12	42,5		30	90	76	M42x1,5
19.6032	60	32	123	68	M12	42,5		30	90	76	M42x1,5
19.6040	60	40	123	98	M12	42,5		30	90	76	M42x1,5
19.6050	60	50	123	98	M12	42,5		30	100	86	M42x1,5
19.8020	80	20	158	68	M12	55		30	100	86	M42x1,5
19.8025	80	25	158	68	M12	55		30	100	86	M42x1,5
19.8032	80	32	158	68	M12	55		30	100	86	M42x1,5
19.8040	80	40	158	98	M12	55		30	100	86	M42x1,5
19.8050	80	50	158	98	M12	55		30	100	86	M42x1,5

Zylinderaufnahmen mit weiteren
d₂ Maßen auf Anfrage.

Side Lock Adaptors with further
d₂ measurements on request.

Autre dimension pour d₂ sur demande.

Bohrstangenhalter

mit zylindrischer Aufnahme
lange Ausführung
DIN 69 880

VDI 3425 Bl. 2
Form 9.1

Boring Bar Holder

with cylindrical Adaptor

DIN 69 880

VDI 3425 Sheet 2
Form 9.1

Porte barre d'alésage

serrage par vis

DIN 69 880

VDI 3425 page 2
Forme 9.1

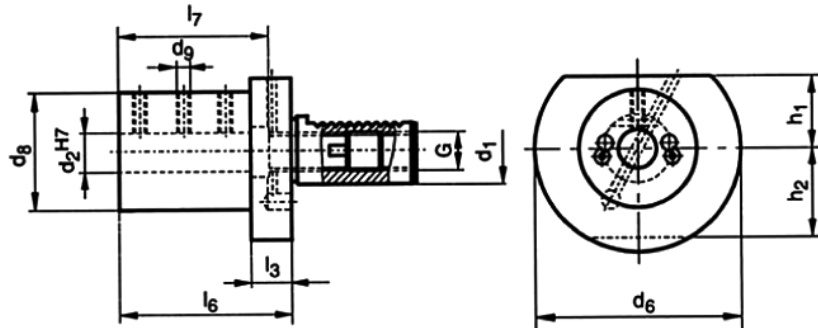

1

Nr./No.	d ₁	d ₂	d ₆	d ₈	d ₉	h ₁	h ₂	l ₃	l ₆	l ₇	G
22.3008	30	8	68	55	M6	28	30	22	85	70	M16x1,5
22.3010	30	10	68	55	M6	28	30	22	85	70	M16x1,5
22.3012	30	12	68	55	M8	28	30	22	85	70	M16x1,5
22.3016	30	16	68	55	M8	28	30	22	85	70	M16x1,5
22.3020	30	20	68	55	M8	28	30	22	85	70	M16x1,5
22.3025	30	25	68	55	M8	28	30	22	85	70	M16x1,5
22.3032	30	32	68	62	M8	28	30	30	85	70	M16x1,5
22.4008	40	8	83	55	M8	32,5	30	22	95	80	M22x1,5
22.4010	40	10	83	55	M8	32,5	30	22	95	80	M22x1,5
22.4012	40	12	83	55	M8	32,5	30	22	95	80	M22x1,5
22.4016	40	16	83	55	M10	32,5	30	22	95	80	M22x1,5
22.4020	40	20	83	55	M10	32,5	30	22	95	80	M22x1,5
22.4025	40	25	83	55	M10	32,5	30	22	95	80	M22x1,5
22.4032	40	32	83	62	M10	32,5	30	30	95	80	M22x1,5
22.4040	40	40	83	70	M10	32,5	30	30	95	80	M22x1,5
22.5012	50	12	98	68	M10	35	30	30	95	78	M28x1,5
22.5016	50	16	98	68	M10	35	30	30	95	78	M28x1,5
22.5020	50	20	98	68	M12	35	30	30	95	78	M28x1,5
22.5025	50	25	98	68	M12	35	30	30	95	78	M28x1,5
22.5032	50	32	98	68	M12	35	30	30	95	78	M28x1,5
22.5040	50	40	98	80	M12	35	30	30	95	78	M28x1,5
22.6016	60	16	123	68	M10	42,5	30	30	100	83	M32x1,5
22.6020	60	20	123	68	M12	42,5	30	30	100	83	M32x1,5
22.6025	60	25	123	68	M12	42,5	30	30	100	83	M32x1,5
22.6032	60	32	123	68	M12	42,5	30	30	100	83	M32x1,5
22.6040	60	40	123	80	M12	42,5	30	30	100	83	M32x1,5

Zylinderaufnahmen mit weiteren
d₂ Maßen auf Anfrage.

Side Lock Adaptors with further
d₂ measurements on request.

Autre dimension pour d₂ sur demande.

Bohrstangenhalter

mit zylindrischer Aufnahme
und geschlitzter Klemmung

Boring Bar Holder

with cylindrical Adaptor
and split clamping

Porte barre d'alésage

serrage par déformation

DIN 69 880

VDI 3425 Bl. 2

DIN 69 880

VDI 3425 Sheet 2

DIN 69 880

VDI 3425 page 2

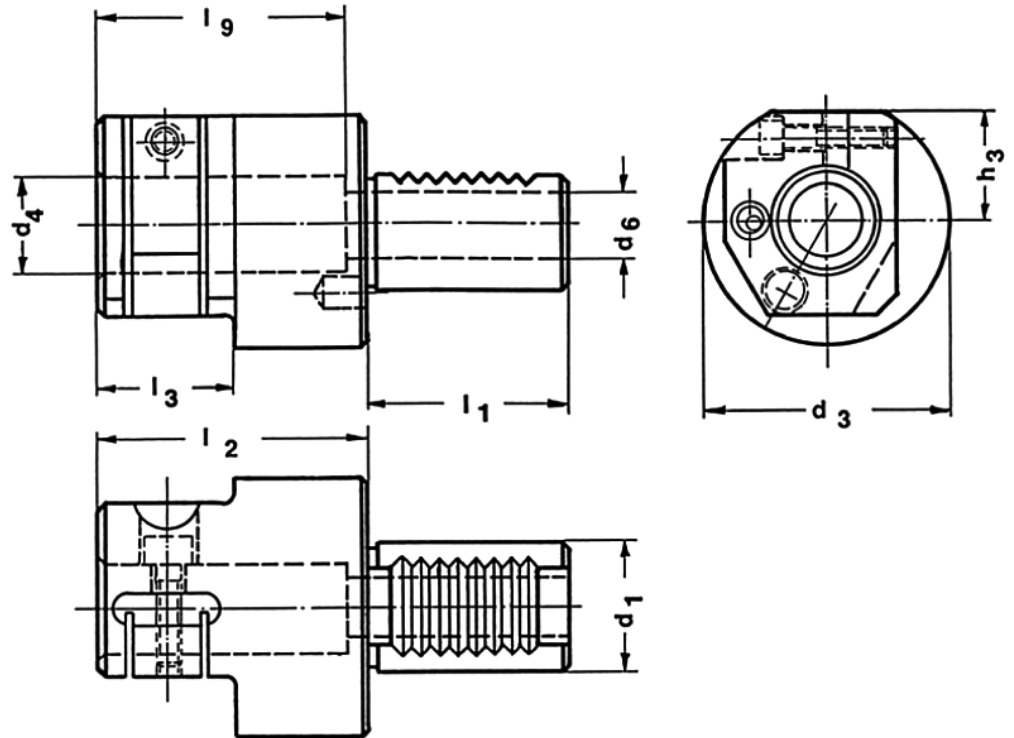

Nr.	d ₁	d ₃	d ₄	d ₆	h ₃	l ₁	l ₂	l ₃	l ₉
24.3020/1	30	68	20	16,4	28	55	60	45	57
24.3020/2	30	68	20	16,4	28	55	85	45	68
24.3025/1	30	68	25	16,4	28	55	60	45	57
24.3025/2	30	68	25	16,4	28	55	85	45	68
24.4025/1	40	83	25	20,4	32,5	63	70	45	58
24.4025/2	40	83	25	20,4	32,5	63	95	45	83
24.4032/1	40	83	32	20,4	32,5	63	70	45	58
24.4032/2	40	83	32	20,4	32,5	63	95	45	83
24.5025/1	50	98	25	20,4	35	78	70	45	67
24.5025/2	50	98	25	20,4	35	78	95	45	88
24.5040/1	50	98	40	26,4	35	78	70	45	67
24.5040/2	50	98	40	26,4	35	78	95	45	88
24.6032/1	60	123	32	26,4	42,5	94	85	55	80
24.6032/2	60	123	32	26,4	42,5	94	100	55	92
24.6040/1	60	123	40	34	42,5	94	85	55	80
24.6040/2	60	123	40	34	42,5	94	100	55	92
24.6050/1	60	123	50	34	42,5	94	85	55	80
24.6050/2	60	123	50	34	42,5	94	100	55	92

Reduzierbuchse

Reducing Sleeve

Douille de réduction

für Werkzeuge mit Zylinderschaft

for tools with cylindrical shaft

Pour outil à queue cylindrique

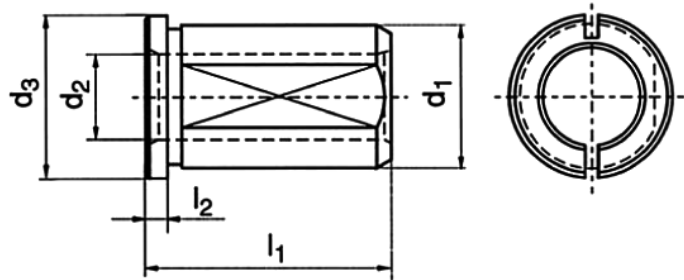

1

Nr./No.	d ₁	d ₂	d ₃	l ₁	l ₂	Nr./No.	d ₁	d ₂	d ₃	l ₁	l ₂
28.2006	20	6	24	30	4	28.3210	32	10	36	50	4
28.2008	20	8	24	30	4	28.3212	32	12	36	50	4
28.2010	20	10	24	30	4	28.3215	32	15	36	50	4
28.2012	20	12	24	30	4	28.3216	32	16	36	50	4
28.2015	20	15	24	30	4	28.3220	32	20	36	50	4
28.2016	20	16	24	30	4	28.3225	32	25	36	50	4
28.2506	25	6	29	40	4	28.4010	40	10	44	78	4
28.2508	25	8	29	40	4	28.4012	40	12	44	78	4
28.2510	25	10	29	40	4	28.4015	40	15	44	78	4
28.2512	25	12	29	40	4	28.4016	40	16	44	78	4
28.2515	25	15	29	40	4	28.4020	40	20	44	78	4
28.2516	25	16	29	40	4	28.4025	40	25	44	78	4
28.2520	25	20	29	40	4	28.4032	40	32	44	78	4
28.3008	30	8	34	50	4	28.5020	50	20	54	88	4
28.3010	30	10	34	50	4	28.5025	50	25	54	88	4
28.3012	30	12	34	50	4	28.5032	50	32	54	88	4
28.3015	30	15	34	50	4	28.5040	50	40	54	88	4
28.3016	30	16	34	50	4	28.6025	60	25	64	88	4
28.3020	30	20	34	50	4	28.6032	60	32	64	88	4
28.3025	30	25	34	50	4	28.6040	60	40	64	88	4
28.3208	32	8	36	50	4	28.6050	60	50	64	88	4

Reduzierbuchsen mit weiteren d₂ Maßen auf Anfrage.

Reducing sleeves d₂ measurements on request.

Douilles de réduction autre dimension pour d₂ sur demande.

Reduzierhülsen

Reducing Sleeve

Douille de réduction

für Werkzeuge mit Zylinderschaft

for tools with cylindrical shaft

Pour outil à queue cylindrique

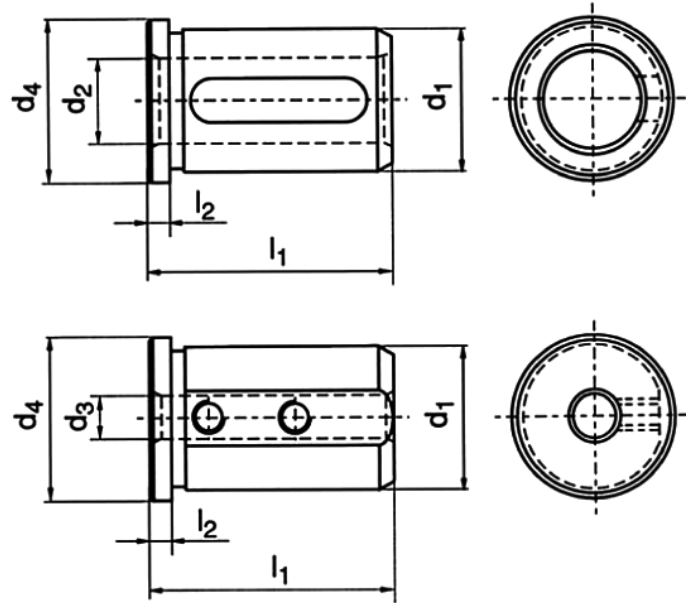

Nr.	d ₁	d ₂	d ₃	d ₄	l ₁	l ₂	Nr./No.	d ₁	d ₂	d ₃	d ₄	l ₁	l ₂
28.2506S	25		6	29	50	4	28.4008S	40		8	44	58	5
28.2508S	25		8	29	50	4	28.4010S	40		10	44	58	5
28.2510S	25		10	29	50	4	28.4012S	40		12	44	58	5
28.2512S	25		12	29	50	4	28.4016S	40	16		44	58	5
28.2516S	25	16		29	50	4	28.4020S	40	20		44	58	5
28.2520S	25	20		29	50	4	28.4025S	40	25		44	58	5
28.3206G200	32		6	40	58	5	28.4032S	40	32		44	58	5
28.3208G200	32		8	40	58	5	28.5012S	50		12	54	75	5
28.3210G200	32		10	40	58	5	28.5016S	50	16		54	75	5
28.3212G200	32		12	40	58	5	28.5020S	50	20		54	75	5
28.3216G200	32	16		40	58	5	28.5025S	50	25		54	75	5
28.3220G200	32	20		40	58	5	28.5032S	50	32		54	75	5
28.3225G200	32	25		40	58	5	28.5040S	50	40		54	75	5

Reduzierhülsen mit weiteren d₂ Maßen auf Anfrage

Reducing sleeves d₂ measurements on request

Douilles de réduction autre dimension pour d₂ sur demande.

WH-Werkzeughalter

für Bohrstangen

Durchmesser und Drehmitte einstellbar
DIN 69 880 VDI 3425 Bl. 2

WH-Toolholder

for Boring Bars

Diameter and turning-centre point adjustable
DIN 69 880 VDI 3425 Sheet 2

Porte outil WH

pour alésage

Diamètre et centrage réglables
DIN 69 880 VDI 3425 page 2

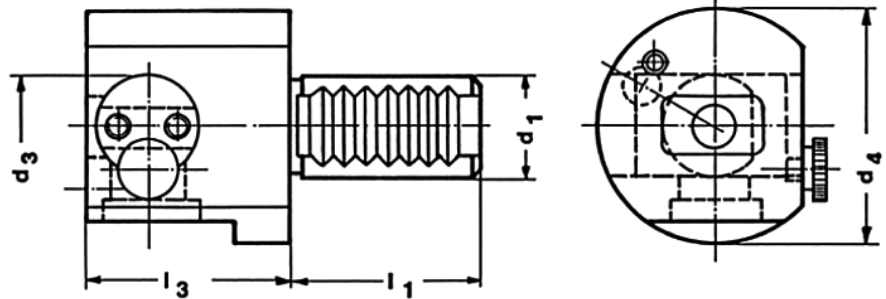

Nr.	d ₁	d ₃	d ₄	l ₁	l ₃
220.100/20	20	28	50	40	50
220.100	30	28	68	55	70
220.110	40	36	83	63	80
220.120	50	46	98	78	90
220.130	60	46	123	94	100
220.140	80	46	158	124	100

WH-Wechselhalter

WH-Reducing Sleeve

WH-Supports interchangeable

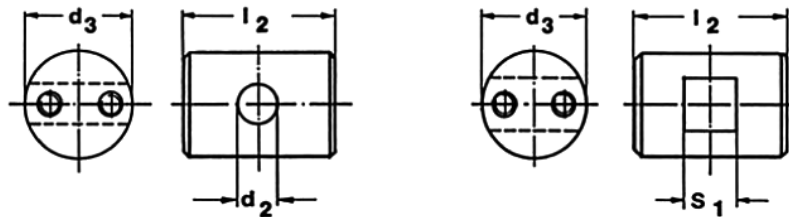

Nr.	d ₃	d ₂	l ₂	Nr.	d ₃	d ₂	l ₂	Nr.	d ₃	d ₂	l ₂
200.106	28	6	32	200.208	36	8	38	200.312	46	12	52
200.108	28	8	32	200.210	36	10	38	200.313	46	13	52
200.110	28	10	32	200.212	36	12	38	200.314	46	14	52
200.112	28	12	32	200.213	36	13	38	200.315	46	15	52
200.113	28	13	32	200.214	36	14	38	200.316	46	16	52
200.114	28	14	35	200.215	36	15	38	200.320	46	20	52
200.115	28	15	35	200.216	36	16	38	200.325	46	25	52
200.116	28	16	35								

Nr.	d ₃	s ₁	l ₂	Nr.	d ₃	s ₁	l ₂	Nr.	d ₃	s ₁	l ₂
210.108	28	8	32	210.210	36	10	38	210.312	46	12	52
210.110	28	10	32	210.212	36	12	38	210.316	46	16	52
210.112	28	12	32	210.216	36	16	38	210.320	46	20	52

Wechselhalter mit weiteren d₂ und s₁ Maßen auf Anfrage

Reducing Sleeves with further d₂ and s₁ measurements on request

Support interchangeable avec autres dimension pour d₂ et s₁ sur demande

Bohrstangenaufnahme

DIN 69 880

VDI 3425 Bl. 2

Boring Bar Adaptor

DIN 69 880

VDI 3425 Sheet 2

Porte barre d'alésage

DIN 69 880

VDI 3425 page 2

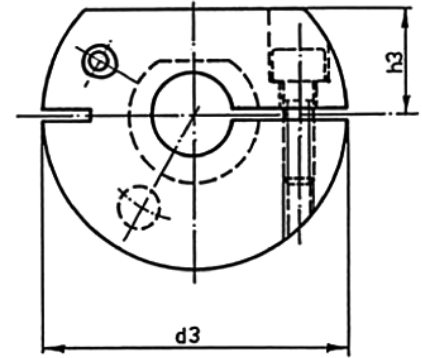
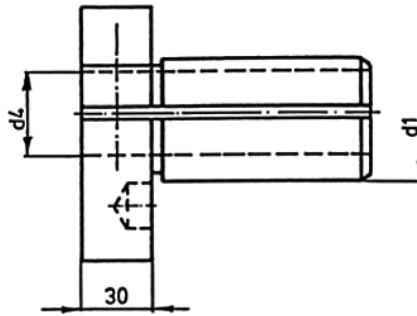

Nr.	d ₁	d ₃	d ₄	h ₃	Nr.	d ₁	d ₃	d ₄	h ₃
20.3012	30	68	12	28	20.5012	50	98	12	35
203016	30	68	16	28	20.5016	50	98	16	35
203020*	30	68	20	28	20.5020	50	98	20	35
204012	40	83	12	32,5	20.5025	50	98	25	35
204016	40	83	16	32,5	20.5032	50	98	32	35
204020	40	83	20	32,5	20.6016	60	123	16	42,5
204025	40	83	25	32,5	20.6020	60	123	20	42,5
204032*	40	83	32	32,5	20.6025	60	123	25	42,5
					20.6032	60	123	32	42,5
					20.6040	60	123	40	42,5

* Diese Abmessungen ohne Verzahnung, da technisch nicht möglich. Bohrstangenaufnahmen mit weiteren d₄ Maßen auf Anfrage

* These measurements are without serrations as this is technically not possible. Further d₄ measurements on request

* Utilisation techniquement non recommandée. Porte barre d'alesage avec autres d₄ dimensions sur demande

Stellhülseaufnahme

DIN 69 880

VDI 3425 Bl. 2

Automotive Adaptor

DIN 69 880

VDI 3425 Sheet 2

Porte embout de réglage

DIN 69 880

VDI 3425 page 2

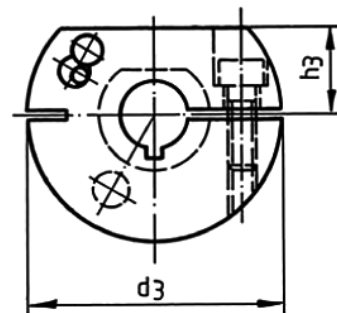
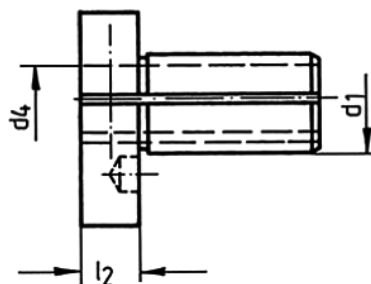

Nr.	d ₁	d ₃	d ₄	h ₃	l ₂	Nr.	d ₁	d ₃	d ₄	h ₃	l ₂
21.3020*	30	68	20	28	30	21.6028	60	123	28	42,5	40
21.4028*	40	83	28	32,5	30	21.6036	60	123	36	42,5	40
21.5028	50	98	28	35	40	21.8028	80	158	28	55	40
21.5036*	50	98	36	35	40	21.8036	80	158	36	55	40
						21.8048	80	158	48	55	40

* Diese Abmessungen ohne Verzahnung, da technisch nicht möglich

* These measurements are without serrations as this is technically not possible

* Utilisation techniquement non recommandée

Stellhülseaufnahme

Automotive Adaptor

Porte outil pour embout de réglage

DIN 69 880

VDI 3425 Bl. 2

DIN 69 880

VDI 3425 Sheet 2

DIN 69 880

VDI 3425 page 2

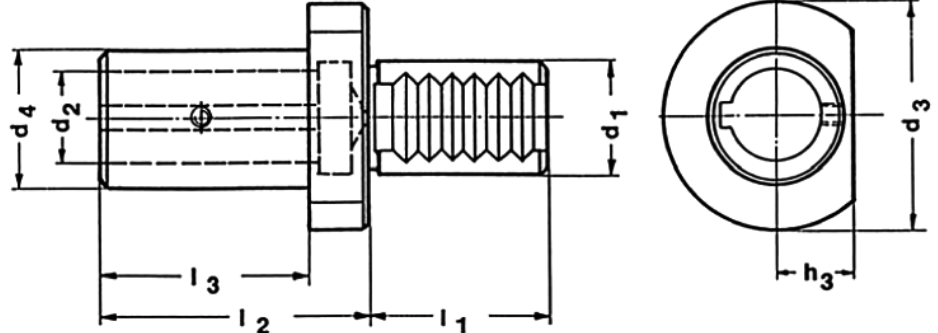
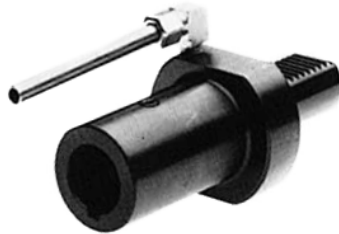

1

Nr.	l_1	d_1	d_2	d_3	d_4	l_2	l_3	h_3
25.300	55	30	28	68	45	95	73	28
25.310	63	40	36	83	52	115	93	32,5
25.320	78	50	48	98	68	145	117	35
25.330	94	60	48	123	68	145	117	42,5

Stellhülseaufnahme

Adjustable Sleeve

Réduction pour embout de réglage

DIN 69 880

VDI 3425 Bl. 2

DIN 69 880

VDI 3425 Sheet 2

DIN 69 880

VDI 3425 page 2

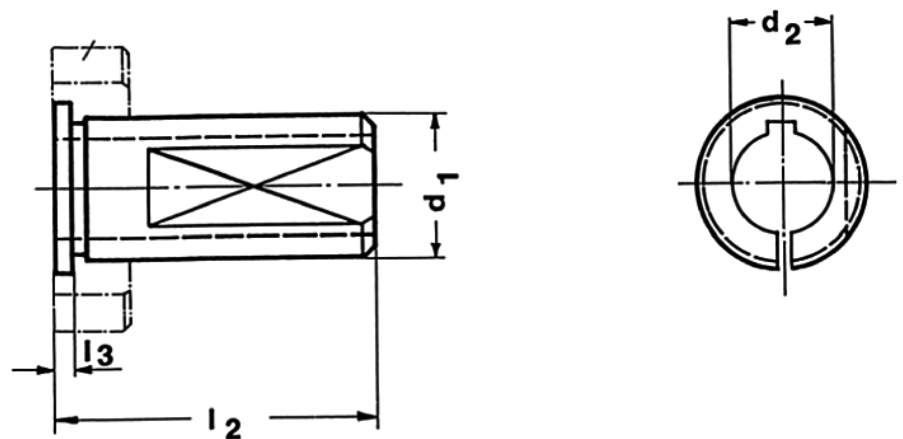

Nr.	d_1	d_2	l_2	l_3
25.350	30	20	77	4
25.360	40	28	85	4
25.370	50	36	106	4
25.380	60	36	122	4
25.390	80	48	152	4

Werkzeughalter mit Zylinderschaft

DIN 69 880 VDI 3425 Bl. 2
Form E1 für Werkzeuge mit innerer
Kühlschmierstoffzuführung

Toolholder with cylindrical shaft Porte outil cylindrique

DIN 69 880 VDI 3425 Sheet 2
Form E1 for tools with inner
cooling systems

DIN 69 880 VDI 3425 page 2
Forme E1
Pour outils à lubrification interne

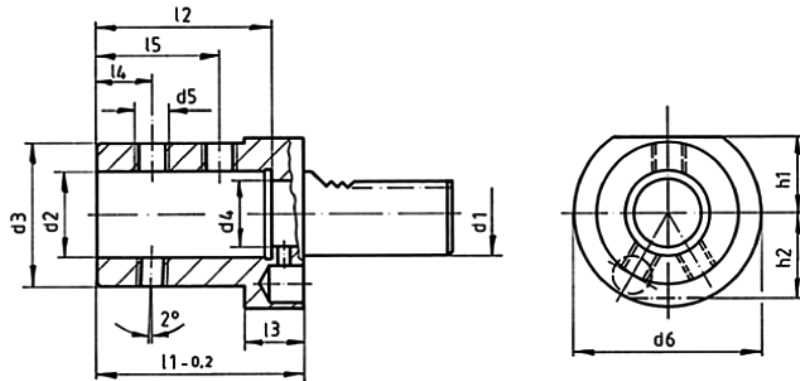

Werkzeughalter sind auch mit
Spannschrauben um 180° versetzt lieferbar.
Bestell-Beispiel: 27.3025/A

Nr.	d ₁	d ₂ H6	d ₃	d ₄	d ₅	d ₆	h ₁	h ₂	l ₁ 0-0,2	l ₂	l ₃	l ₄	l ₅
27.2016	20	16	36	12	M10x1	50	23	23	67	54	18	15	35
27.2020	20	20	40	12	M10x1	50	23	23	67	54	18	15	35
27.2025	20	25	45	17	M12x1	50	23	23	71	59	18	17	40
27.2516	25	16	36	12	M10x1	58	25	25	67	54	18	15	35
27.2520	25	20	40	12	M10x1	58	25	25	67	54	18	15	35
27.2525	25	25	45	17	M12x1	58	25	25	71	59	18	17	40
27.3016	30	16	36	12	M10x1	68	28	30	67	54	22	15	35
27.3020	30	20	40	12	M10x1	68	28	30	67	54	22	15	35
27.3025	30	25	45	17	M12x1	68	28	30	71	59	22	17	40
27.3032	30	32	52	24	M12x1	68	28	30	75	63	22	20	44
27.3040	30	40	65	32	M16x1	68	28	30	90	73	22	22	50
27.4016	40	16	36	12	M10x1	83	32,5		67	54	22	15	35
27.4020	40	20	40	12	M10x1	83	32,5		67	54	22	15	35
27.4025	40	25	45	17	M12x1	83	32,5		75	59	22	17	40
27.4032	40	32	52	24	M12x1	83	32,5		75	63	22	20	44
27.4040	40	40	64,5	32	M16x1	83	32,5		90	73	22	22	50
27.4050	40	50	75	32	M16x1	83	32,5		100	83	30	24	60
27.5020	50	20	40	12	M10x1	98	35		67	54	30	15	35
27.5025	50	25	45	17	M12x1	98	35		80	59	30	17	40
27.5032	50	32	52	24	M12x1	98	35		80	63	30	20	44
27.5040	50	40	65	32	M16x1	98	35		90	73	30	22	50
27.5050	50	50	75	42	M16x1	98	35		100	83	30	24	60
27.6020	60	20	40	12	M10x1	123	42,5		80	54	30	15	35
27.6025	60	25	45	17	M12x1	123	42,5		80	59	30	17	40
27.6032	60	32	52	24	M12x1	123	42,5		80	63	30	20	44
27.6040	60	40	65	32	M16x1	123	42,5		90	73	30	22	50
27.6050	60	50	75	42	M16x1	123	42,5		100	83	30	24	60
27.8020	80	20	40	12	M10x1	158	55		80	54	40	15	35
27.8025	80	25	45	17	M12x1	158	55		80	59	40	17	40
27.8032	80	32	52	24	M12x1	158	55		80	63	40	20	44
27.8040	80	40	65	32	M16x1	158	55		90	73	40	22	50
27.8050	80	50	75	42	M16x1	158	55		100	83	40	24	60

Werkzeughalter mit Zylinderschaft

DIN 69 880 VDI 3425 Bl. 2
Form E1 für Werkzeuge mit innerer
Kühlschmierstoffzuführung

Toolholder with cylindrical shaft Porte outil cylindrique shaft

DIN 69 880 VDI 3425 Sheet 2
Form E1 for tools with inner
cooling systems

DIN 69 880 VDI 3425 page 2
Forme E1
Pour outils à lubrification interne

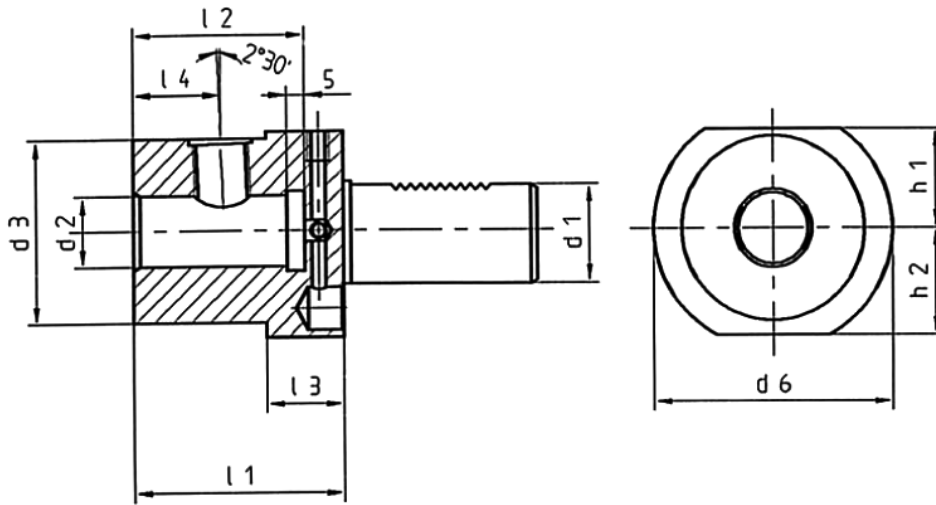

Für $d_2 = 25$ und größer sind 2 Klemmschrauben vorgesehen
Für Werkzeuge nach DIN 1835 und DIN 6535
Technisch bedingte Änderungen vorbehalten

EWS-Nr.	d_1	d_2	d_3	d_6	h_1	h_2	l_1	l_2	l_3	l_4
27.2006WN	20	6	45	50	23	23	60	40	22	18
27.2008WN	20	8	45	50	23	23	60	40	22	18
27.2010WN	20	10	45	50	23	23	60	44	22	20
27.2012WN	20	12	45	50	23	23	60	49	22	22,5
27.2014WN	20	14	45	50	23	23	62	49	22	22,5
27.2016WN	20	16	45	50	23	23	67	52	22	24
27.2018WN	20	18	45	50	23	23	67	52	22	24
27.2020WN	20	20	45	50	23	23	67	52	22	25
27.2025WN	20	25	45	50	23	23	67	54	22	-
27.3006WN	30	6	52	68	28	30	67	35	22	18
27.3008WN	30	8	52	68	28	30	67	35	22	18
27.3010WN	30	10	52	68	28	30	67	39	22	20
27.3012WN	30	12	52	68	28	30	67	44	22	22,5
27.3014WN	30	14	52	68	28	30	67	44	22	22,5
27.3016WN	30	16	52	68	28	30	67	47	22	24
27.3018WN	30	18	52	68	28	30	67	47	22	24
27.3020WN	30	20	52	68	28	30	67	52	22	25
27.3025WN	30	25	63	68	28	30	67	54	22	-
27.3032WN	30	32	65	68	28	30	75	63	22	-
27.4006WN	40	6	52	83	32,5	41,5	67	35	22	18
27.4008WN	40	8	52	83	32,5	41,5	67	35	22	18
27.4010WN	40	10	52	83	32,5	41,5	67	39	22	20
27.4012WN	40	12	52	83	32,5	41,5	67	44	22	22,5
27.4014WN	40	14	52	83	32,5	41,5	67	44	22	22,5
27.4016WN	40	16	52	83	32,5	41,5	67	47	22	24
27.4018WN	40	18	52	83	32,5	41,5	67	47	22	24
27.4020WN	40	20	52	83	32,5	41,5	67	52	22	25
27.4025WN	40	25	63	83	32,5	41,5	67	54	22	-
27.4032WN	40	32	65	83	32,5	41,5	75	63	22	-

Kegelaufnahme

DIN 69 880 Teil 7 VDI 3425 Bl. 2
Form F für Kegelschäfte
mit Austreibblappen

Morse Taper Adaptor

DIN 69 880 Part 7 VDI 3425 Sheet 2
Form F for shanks with Tang

Porte outil à cône Morse

DIN 69 880 Partie 7 VDI 3425 page 2
Forme F pour cône Morse à tenon

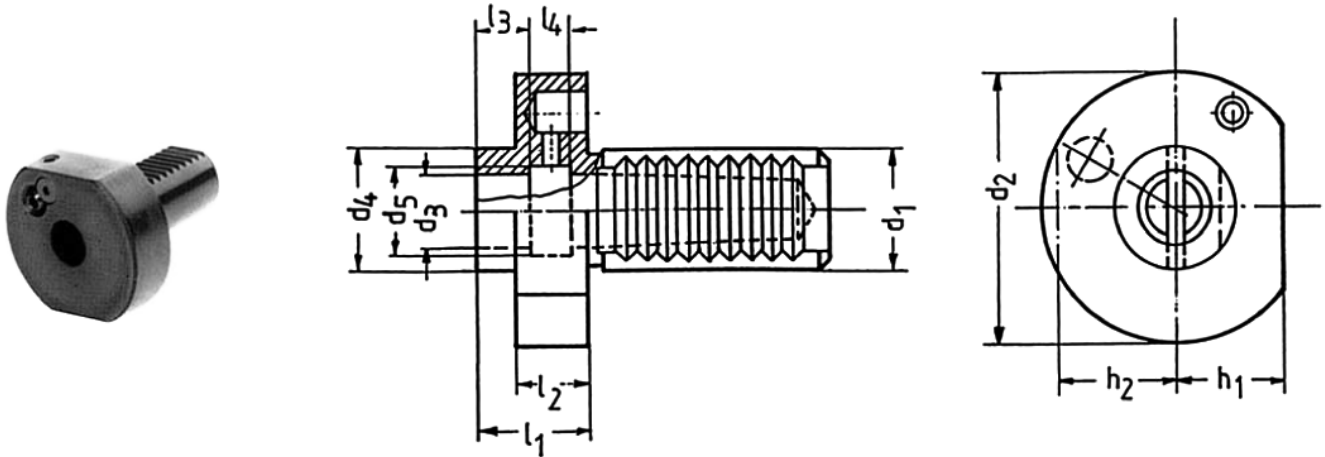

Nr.	d ₁	MK	d ₂	d ₃	d ₄	d ₅	h ₁	h ₂	l ₁	l ₂	l ₃	l ₄
25.1610	16	1	40			13,5	18	18	43		16	12
25.2010	20	1	50	12,065		13,5	23	23	23		16	12
25.2020*	20	2	50	17,780		19,5	23	23	55		20	12
25.2510	25	1	58	12,065		3	25	25	23		16	12
25.2520	25	2	58	17,780		5	25	25	27		20	12
25.3010	30	1	68	12,065		13,5	28	30	27		16	12
25.3020	30	2	68	17,780		19,5	28	30	27		20	12
25.3030	30	3	68	23,825		24,5	28	30	45		30	12
25.4010	40	1	83	31,267	55	13,5	32,5		36	22	16	12
25.4020	40	2	83	17,780	55	19,5	32,5		36	22	20	12
25.4030	40	3	83	23,825	58	24,5	32,5		36	22	30	12
25.4040	40	4	83	31,267	68	32	32,5		80	22	40	14
25.5020	50	2	98	17,780	55	19,5	35		36	30	20	12
25.5030	50	3	98	23,825	58	24,5	35		36	30	30	12
25.5040	50	4	98	31,267	68	32	35		50	30	40	14
25.6020	60	2	123	17,780	58	19,5	42,5		36	30	20	12
25.6030	60	3	123	23,825	58	24,5	42,5		36	30	30	12
25.6040	60	4	123	31,267	68	32	42,5		50	30	40	14
25.6050	60	5	123	44,399	98	44	42,5		63	30	52	16
25.8040	80	4	158	31,267	68	32	55		50	40	40	14
25.8050	80	5	158	44,399	98	44	55		50	40	52	16

* Diese Abmessung ohne Verzahnung
da technisch nicht möglich

* These measurements are without
serrations as this is technically not possible

* Utilisation technique non
recommandée

Reduzierhülse

DIN 69 880

VDI 3425 Bl. 2

Reducing Sleeve

DIN 69 880

VDI 3425 Sheet 2

Réduction pour cone Mose

DIN 69 880

VDI 3425 page 2

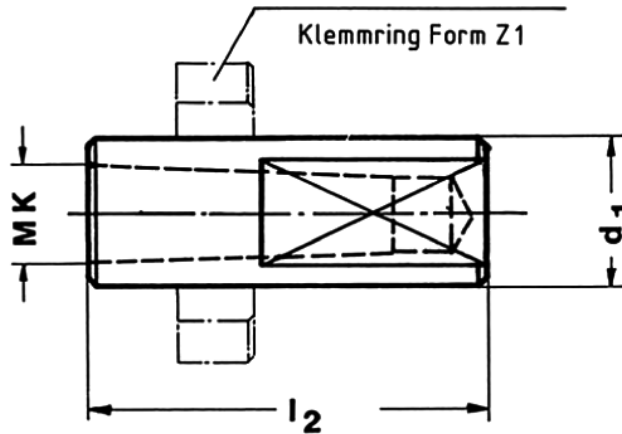

Nr.	d ₁	MK	l ₂
25.400/20MK1	20	1	76
25.400/MK1	30	1	76
25.400/MK2	30	2	71
25.400/MK3	30	3	90
25.410/MK1	40	1	95
25.410/MK2	40	2	95
25.410/MK3	40	3	95
25.410/MK4	40	4	114
25.420/MK2	50	2	114
25.420/MK3	50	3	114
25.420/MK4	50	4	114
25.430/MK3	60	3	150
25.430/MK4	60	4	150
25.430/MK5	60	5	150
25.440/MK4	80	4	150
25.440/MK5	80	5	150

Klemmring

mit Kühlmittelzufuhr

Form Z1

Clamping Ring

with Cooling intake

Form Z1

Bague de serrage

avec lubrification

Form Z1

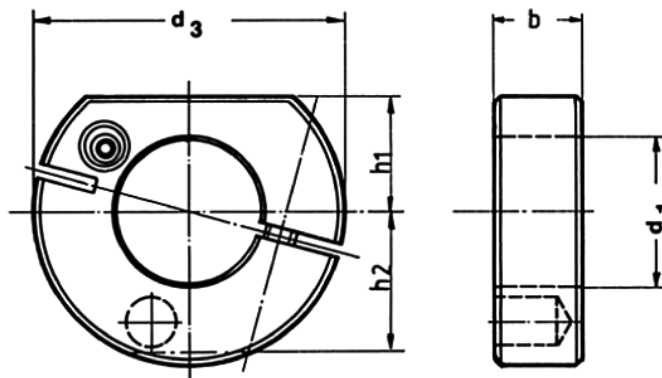

Nr.	d ₁	d ₃	b	h ₁	h ₂
25.450/20	20	50	15	23	23
25.450/25	25	58	16	25	25
25.450	30	68	20	28	30
25.460	40	83	22	32,5	
25.470	50	98	30	35	
25.480	60	123	30	42,5	
25.490	80	158	40	55	

1

Werkzeughalter mit Zylinderschaft

DIN 69 880
Form E3 / E4
mit Zylinderaufnahme durch Spannzange

VDI 3425 Bl. 2
Form 10.1

Collet Chuck

DIN 69 880
Form E3 / E4
with cylindrical adaption by collet

VDI 3425 Sheet 2
Form 10.1

Porte pince

DIN 69 880
Forme E3 / E4
Avec serrage cylindrique sur le diamètre

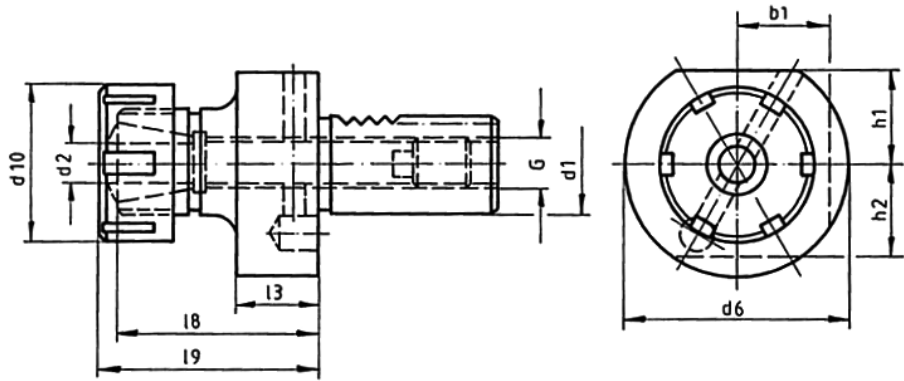

Nr.	d ₁	d ₂	d ₆	d ₁₀	b ₁	l ₃	l ₈	l ₉	h ₁	h ₂	G	passende Spannzangen Collet type Pince à utiliser
Form E4												
31.1616	16	0,5 -10	40	28		13	30	40	18	18	M 8 x 1	160 426E
31.1620	16	1 -13	40	34		13	33	44	18	18	M 8 x 1	200 428E
31.2016	20	0,5 -10	50	28		18	30	40	23	23	M 10 x 1	160 426E
31.2025	20	1 -16	50	42		18	38	50	23	23	M 10 x 1	250 430E
31.2032	20	2 -20	50	50		18	49	62	23	23	M 10 x 1	320 470E
31.2040	20	3 -26	50	63		22	52	66	23	23	M 10 x 1	400 472E
31.2525	25	1 -16	58	42		18	45	57	25	25	M 14 x 1,5	250 430E
31.2532	25	2 -20	58	50		18	49	62	25	25	M 14 x 1,5	320 470E
31.3025	30	1 -16	68	42	30	22	45	57	28	30	M 18 x 1,5	250 430E
31.3032	30	2 -20	68	50	30	22	49	62	28	30	M 18 x 1,5	320 470E
31.3040	30	3 -26	68	63	30	22	56	70	28	30	M 18 x 1,5	400 472E
31.4025	40	1 -16	83	42		22	50	62	32,5		M 22 x 1,5	250 430E
31.4032	40	2 -20	83	50		22	49	62	32,5		M 22 x 1,5	320 470E
31.4040	40	3 -26	83	63		22	61	75	32,5		M 22 x 1,5	400 472E
31.5040	50	3 -26	98	63		30	61	75	35		M 28 x 1,5	400 472E
31.6040	60	3 -26	123	63		30	61	75	42,5		M 42 x 1,5	400 472E
Form E3												
31.2023	20	1,5 -16	50	43		18	42	57	23	23	M 10 x 1	025 415E
31.2523	25	1,5 -16	58	43		18	42	57	25	25	M 14 x 1,5	025 415E
31.3023	30	1,5 -16	68	43	30	22	42	57	28	30	M 18 x 1,5	025 415E
31.3033	30	1,5 -25	68	60	30	22	59	75	28	30	M 18 x 1,5	035 462E
31.4023	40	1,5 -16	83	43		22	42	57	32,5		M 22 x 1,5	025 415E
31.4033	40	1,5 -25	83	60		22	59	75	32,5		M 22 x 1,5	035 462E
31.4041	40	3,5 -32	83	72		22	73	90	32,5		M 22 x 1,5	044 467E
31.5033	50	1,5 -25	98	60		30	59	75	35		M 28 x 1,5	035 462E
31.5041	50	3,5 -32	98	72		30	73	90	35		M 28 x 1,5	044 467E
31.6041	60	3,5 -32	123	72		30	73	90	42,5		M 42 x 1,5	044 467E
31.6049	60	9,5 -40	123	85		30	82	100	42,5		M 42 x 1,5	052 468E
31.8049	80	9,5 -40	158	85		40	82	100	55		M 42 x 1,5	052 468E

Spannzangen

Type RD/ER
DIN 6499

Collets

Type RD/ER
DIN 6499

Pince de serrage

Type RD/ER
DIN 6499

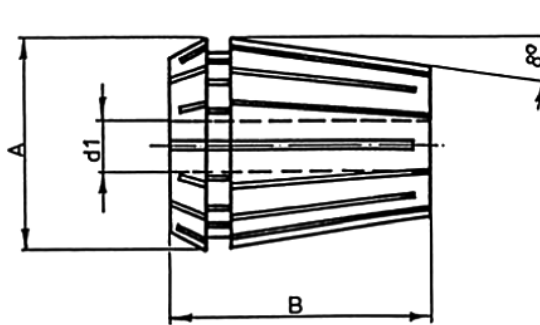

Nr.	lieferbare Bohrungs-Ø capacity capacité-Ø	stg. mm inc. mm progr. mm	Spannbereich d ₁ span-d ₁ serrage d ₁	A	B
110 4008E	1- 7	0,5	0,5- 7	11,5	18
120 424E	1- 3	0,5	0,5- 3	11,8	19,5
120 424E	4- 7	1	3 - 7	11,8	19,5
160 426E	1-10	1	0,5-10	17	27
200 428E	2-13	1	1 -13	21	31
250 430E	2-16	1	1 -16	26	35
320 470E	3-20	1	2 -20	33	40
400 472E	4-26	1	3 -26	41	46
500 477E	12-34	2	10 -34	52	60

Type DIN 6388

Form B



Type DIN 6388

Form B

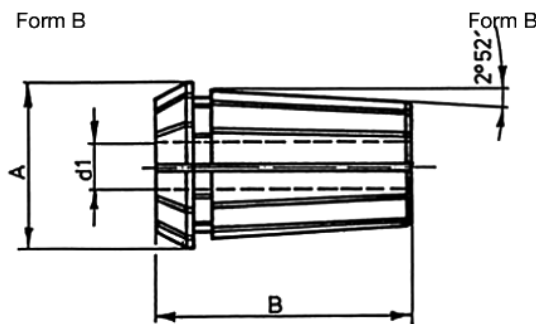

Type DIN 6388

Form B

Nr.	lieferbare Bohrungs-Ø capacity capacité-Ø	stg. mm inc. mm progr. mm	Spannbereich d ₁ span-d ₁ serrage d ₁	A	B
025 415E	2-16	0,5	1,5- 16	25,5	40
035 462E	2-25	0,5	1,5- 25	35,5	52
044 467E	4-32	0,5	3,5- 32	44	60
052 468E	10-40	0 5	9,5- 40	52,7	68

Spannschlüssel



Key

Nr.	für Spannzange/for Collets/pour Pince de serrage
225	250 430E
232	320 470E
240	400 472E
250	500 474E

Clé

Nr.	für Spannzange/for Collets/pour Pince de serrage
416	025 415E
425	035 462E
432	044 467E
440	052 468E

1

Spannzangen DIN 6499 A

zum Gewindeschneiden

Collets DIN 6499 A

for Tapping

Pince de serrage

pour la coupe de filetage

Ohne Längenausgleich
without compensation
sans compensation
Daten Rubrik 8 Seite 11

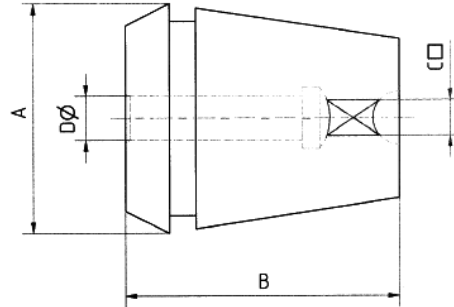

Mit Längenausgleich auf Zug
tension type
avec compensation par traction
Daten Rubrik 8 Seite 13

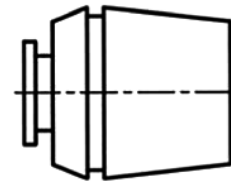
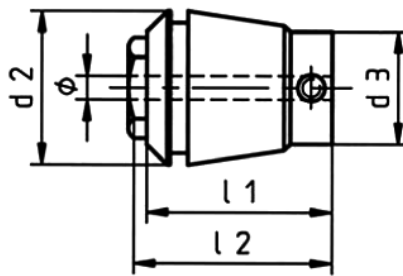

Spannzangen DIN 6499 A

für Werkzeuge mit Innenkühlung

Collets DIN 6499 A

for tools with internal cooling system

Pinces de serrage

pour outils avec liquide d'arrossage intérieure

Abgedichtet
Sealed / étouppé
P max 70 bar

Daten Rubrik 8 Seite 12

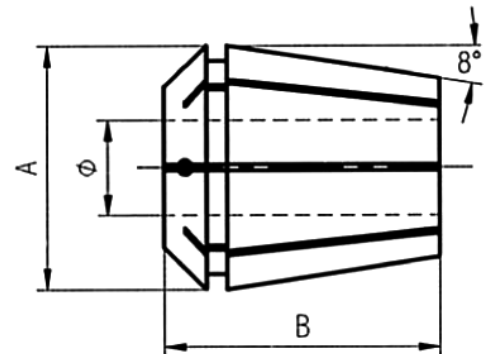

Mit 4 Schrägbohrungen an Stirnseite
With 4 angle holes on front side
avec 4 alésages refroidissants au front



Kugeldüse Ø 10

mit 45° Schrägbohrung

Coolant nozzle

with 45° angle hole

Tuyère réfrigérante

avec une alésage biaisé de 45°

Nr.
KD 10x4 - 45°
KD 10x4 - 45° L30

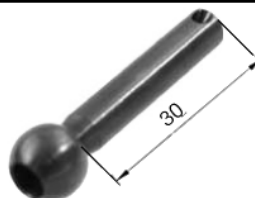

Reduzierbuchse

mit integrierter Kugeldüse
und Ausrichtschraube

Reducing sleeve

with integrated coolant hole
and alignment screw

Douille de réduction

avec une tuyère réfrigérante intégrée
et un boulon de l'alignement

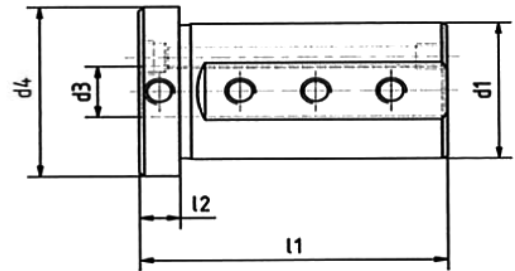
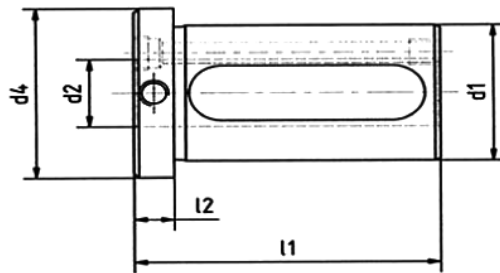

Nr.	d ₁	d ₂	d ₃	d ₄	l ₁	l ₂	Nr.	d ₁	d ₂	d ₃	d ₄	l ₁	l ₂
28.2506SIK	25		6	29	54	8	28.4006SIK	40		6	45	61	8
28.2508SIK	25		8	29	54	8	28.4008SIK	40		8	45	61	8
28.2510SIK	25		10	29	54	8	28.4010SIK	40		10	45	61	8
28.2512SIK	25		12	29	54	8	28.4012SIK	40		12	45	61	8
28.2515SIK	25	15		40	54	8	28.4016SIK	40	16		45	61	8
28.2516SIK	25	16		40	54	8	28.4020SIK	40	20		45	61	8
28.3206G200IK	32		6	40	61	8	28.4025SIK	40	25		45	61	8
28.3208G200IK	32		8	40	61	8	28.5010SIK	50		10	54	78	8
28.3210G200IK	32		10	40	61	8	28.5012SIK	50		12	54	78	8
28.3212G200IK	32		12	40	61	8	28.5016SIK	50	16		54	78	8
28.3215G200IK	32	15		40	61	8	28.5020SIK	50	20		54	78	8
28.3216G200IK	32	16		40	61	8	28.5025SIK	50	25		54	78	8
28.3220G200IK	32	20		40	61	8	28.5032SIK	50	32		54	78	8

ABS®-Aufnahmen (Lizenz Komet)

DIN 69 880/VDI

ABS®-adaptors (Komet license)

DIN 69 880/VDI

Mandrins ABS® (Licence Komet)

DIN 69 880/VDI

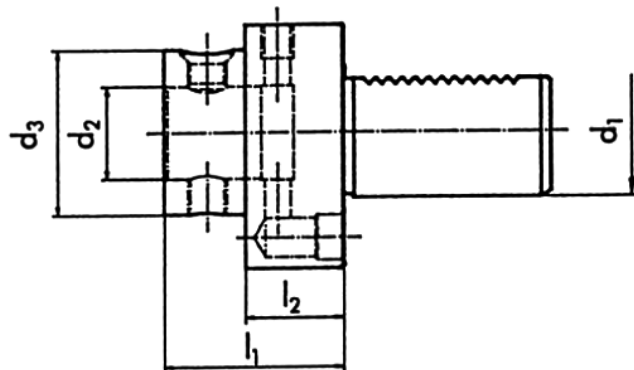

Nr.	ABS	d ₁	d ₂	d ₃	l ₁	l ₂
19.30ABS50	50	30	28	50	60	40
19.40ABS50	50	40	28	50	60	40
19.40ABS63	63	40	34	63	70	45
19.40ABS80	80	40	46	80	75	50
19.50ABS50	50	50	28	50	65	35
19.50ABS63	63	50	34	63	75	45
19.50ABS80	80	50	46	80	75	45
19.60ABS50	50	60	28	50	65	35
19.60ABS63	63	60	34	63	75	45
19.60ABS80	80	60	46	80	75	45

Hydro-Dehnspannfutter

DIN 69 880/VDI

Hydraulik collet-chuck

DIN 69 880/VDI

Mandrin expansible

DIN 69 880/VDI

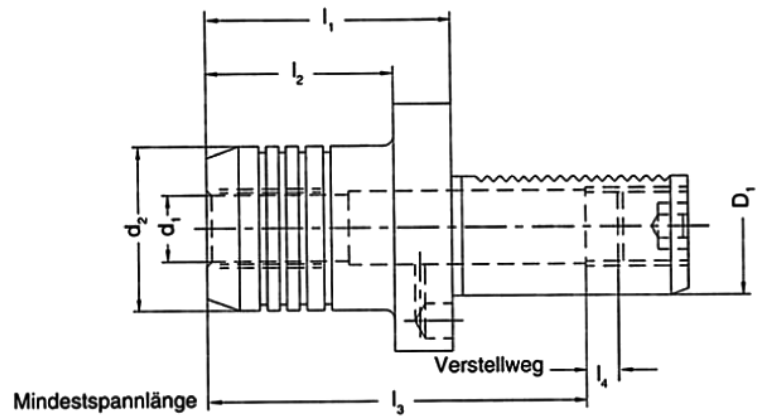

Nr.	D ₁	d ₁	d ₂	l ₁	l ₂	l ₃	l ₄
19.3006HYD	30	6	26	49	33	90	10
19.3008HYD	30	8	28	49	33	90	10
19.3010HYD	30	10	30	49	33	90	10
19.3012HYD	30	12	32	54	38	95	10
19.3014HYD	30	14	34	54	38	95	10
19.3016HYD	30	16	38	89	73	130	10
19.3018HYD	30	18	40	89	73	130	10
19.3020HYD	30	20	42	89	73	130	10
19.3025HYD	30	25	50	94	78	95	10
19.3032HYD	30	32	60	94	78	95	10
19.4006HYD	40	6	26	55	33	90	10
19.4008HYD	40	8	28	55	33	90	10
19.4010HYD	40	10	30	55	33	90	10
19.4012HYD	40	12	32	60	38	95	10
19.4014HYD	40	14	34	60	38	95	10
19.4016HYD	40	16	38	95	73	130	10
19.4018HYD	40	18	40	95	73	130	10
19.4020HYD	40	20	42	95	73	130	10
19.4025HYD	40	25	50	95	73	130	10
19.4032HYD	40	32	60	95	78	95	10

NC Kurzbohrfutter

NC-Short Drill Chuck

Mandrin de perçage NC construction monobloc

DIN 69 880

VDI 3425 Bl. 2

DIN 69 880

VDI 3425 Sheet 2

DIN 69 880

VDI 3425 page 2

Type A Spannen zentral durch Schaft
Type B Spannen seitlich von außen
Kühlmittelzuführung über Spritzdüsen

Chucking by shaft
Chucking from outside
External cooling system

Serrage central traversant
Serrage centrique externe
Pour outils à lubrification externe

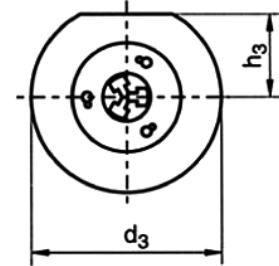
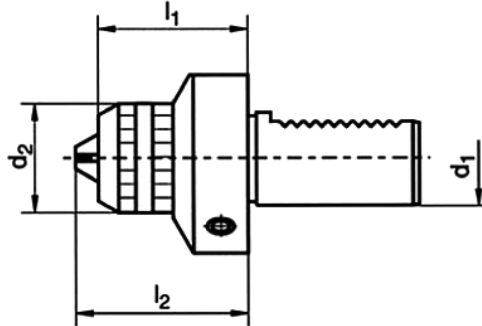

Nr.	Type	Spann- bereich Chucking Capacity serrage	Maße/Dimensions					
			d1	d2	d3	h3	l1	l2max.
25.550/20	A	0,5-10	20	50	50		38	45
25.433	B	0,5-8	16	40			60	63
25.443	B	0,5-8	20	40		23	60	63
25.444	B	0,5-8	25	40	28	25	60	63
25.453	B	0,5-8	30	40	32,5	28	60	63
25.463	B	0,5-8	40	40	32,5	32,5	65	68

Nr.	Type	Spann- bereich Chucking Capacity serrage	Maße/Dimensions					
			d1	d2	d3	h3	l1	l2max.
25.543	B	1-13	20	57	56		82	88
25.544	B	1-13	25	57	58		82	88
25.553	B	1-13	30	57	68	28	82	88
25.563	B	1-13	40	57	83	32,5	82	91
25.573	B	1-13	50	57	98	35	86	92
25.552	B	3-16	30	57	68	28	82	93
25.562	B	3-16	40	57	83	32,5	85	96
25.572	B	3-16	50	57	98	35	86	97
25.582	B	3-16	60	57	123	42,5	95,5	106,5

Kühlmittelzufuhr zentral
durch das Futter und Werkzeug

Internal cooling system

Pour outils à lubrification interne

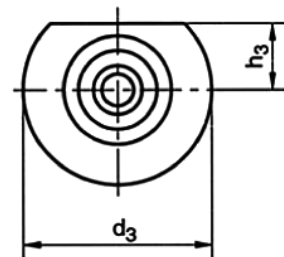
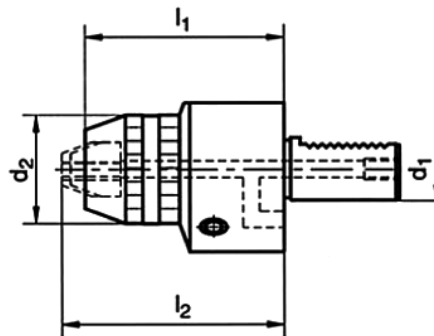

Nr.	Spann- bereich Chucking Capacity serrage	d1	Maße/Dimensions				l1	l2max.
			d2	d3	h3			
25.535.0	0,5-8	16	36	40	16	68	71	
25.545.0	0,5-8	20	36	50	23	68	71	
25.546.0	0,5-8	25	36	58	25	68	71	
25.555.0	0,5-8	30	36	68	28	68	71	
25.565.0	0,5-8	40	36	83	32,5	68	71	

Nr.	Spann- bereich Chucking Capacity serrage	d1	Maße/Dimensions				l1	l2max.
			d2	d3	h3			
25.545	1-13	20	50	50		90	96	
25.546	1-13	25	50	58		90	96	
25.555	1-13	30	50	68	28	90	96	
25.565	1-13	40	50	83	32,5	90	96	
25.575	1-13	50	50	98	35	90	96	
25.555.1	3-16	30	57	68	28	90	101	
25.565.1	3-16	40	57	83	32,5	90	101	
25.575.1	3-16	50	57	98	35	90	101	
25.585.1	3-16	60	57	123	42,5	93	104	

1

Werkstoffanschlag

Stock Stop

Porte util à butée de longueur

mitlaufend, Länge verstellbar
DIN 69 880 VDI 3425 Bl. 2

revolving, adjustable length
DIN 69 880 VDI 3425 Sheet 2

longueur réglable
DIN 69 880 VDI 3425 page 2

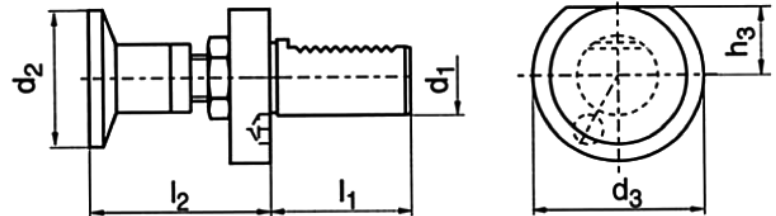

Nr.	d ₁	d ₂	d ₃	h ₃	l ₁	l ₂
*25.500/16	16	28	40	18	32	64
*25.500/20-26	20	26	50	23	40	50-70
*25.500/20-32	20	32	50	23	40	50-70
*25.500/20-42	20	42	50	23	40	50-70
25.500/25-26	25	26	58	25	48	50-70
25.500/25-32	25	32	58	25	48	50-70
25.500/25-42	25	42	58	25	48	50-70
25.500-32	30	32	68	28	55	62-95
25.500-42	30	42	68	28	55	62-95
25.500-58	30	58	68	28	55	62-95
25.510-32	40	32	83	32,5	63	62-95
25.510-42	40	42	83	32,5	63	62-95
25.510-58	40	58	83	32,5	63	62-95

* Diese Abmessungen ohne Verzahnung, da technisch nicht möglich

* These measurements are without serrations as this is technically not possible

* Utilisation techniquement non recommandée

Bohrfutteraufnahme

Drill Chuck Adaptor

Porte mandrin de perçage

DIN 69 880

VDI 3425 Bl. 2

DIN 69 880

VDI 3425 Sheet 2

DIN 69 880

VDI 3425 page 2

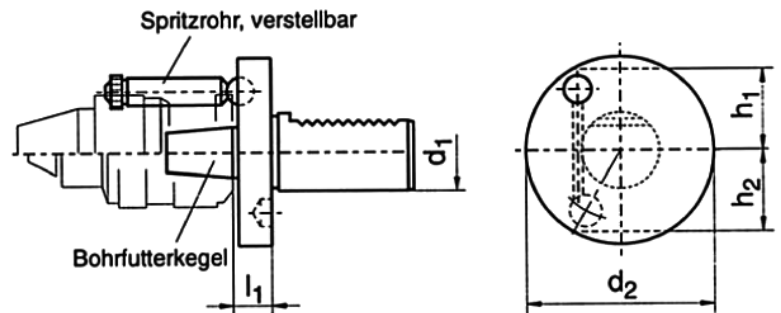

Nr.	d ₁	d ₂	Bohrfutterkegel Taper Cône	l ₁	h ₁	h ₂
25.551/16	16	40	B12	20		18
25.551/20	20	50	B12	20		23
25.551/30	30	68	B16	20	28	30
25.551/40	40	83	B16	20	32,5	
25.551/50	50	98	B16	20	35	

Räumwerkzeughalter Räumstempel

Broaching tool holder Broaching cutters

Porte-outils de brochage Outils de brochage hexagonal interne

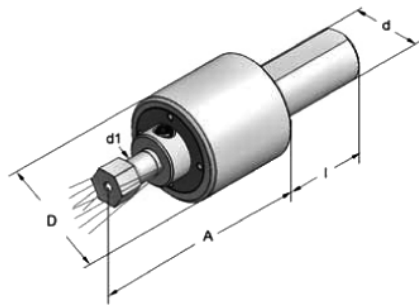

Zylinderschaft
cycl. shank
Manche du cylindre

Nr.	d	d ₁	D	l	A
RWZ 20.08.5010	20	8	40	38	65
RWZ 25.08.5010	25	8	40	48	65
RWZ 25.12.5010	25	12	50	55	88

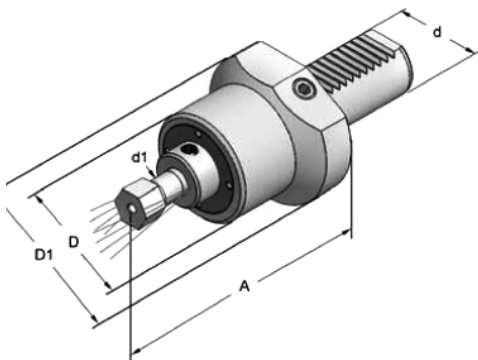

DIN 69880
VDI

Nr.	d	d ₁	D	D ₁	A
RWZ16.08.5000	16	8	40	44	70
RWZ20.08.5000	20	8	40	50	70
RWZ25.08.5000	25	8	40	58	70
RWZ30.12.5000	30	12	50	68	96
RWZ40.12.5000	40	12	50	83	96

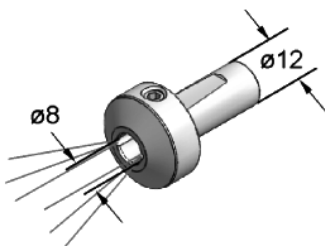

Reduzierung
Reduction

Nr.
RWZ12.08.5000

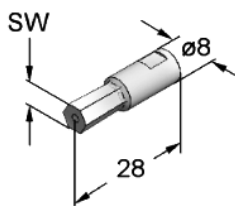

Räumstempel SW
Hexagonal broach SW

Nr.	SW	Ø	Nr.	TORX	Ø
P0828-2	2	8	P0828-T6	6	8
P0828-2,5	2,5	8	P0828-T7	7	8
P0828-3	3	8	P0828-T8	8	8
P0828-4	4	8	P0828-T10	10	8
P0828-5	5	8	P0828-T15	15	8
P0828-6	6	8	P0828-T20	20	8
P0828-8	8	8	P0828-T25	25	8
P0828-10	10	8	P0828-T27	27	8
P1255-4	4	12	P0828-T30	30	8
P1255-5	5	12	P0828-T40	40	8
P1255-6	6	12	P0828-T45	45	8
P1255-8	8	12	P0828-T50	50	8
P1255-10	10	12			
P1255-12	12	12			
P1255-14	14	12			
P1255-17	17	12			

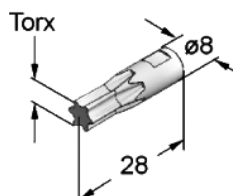
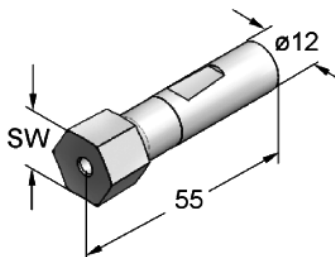

Räumstempel TORX
Broaching cutters TORX

Sonderprofile auf Anfrage · Special profiles in inquiry

Gewindeschneidkopf für RD/ER Spannzangen

Tap-Cuttinghead with RD/ER collets

Tête de taraudage avec RD/ER pince de serrage

DIN 69 880

VDI 3425 Bl. 2

DIN 69 880

VDI 3425 Sheet 2

DIN 69 880

VDI 3425 page 2

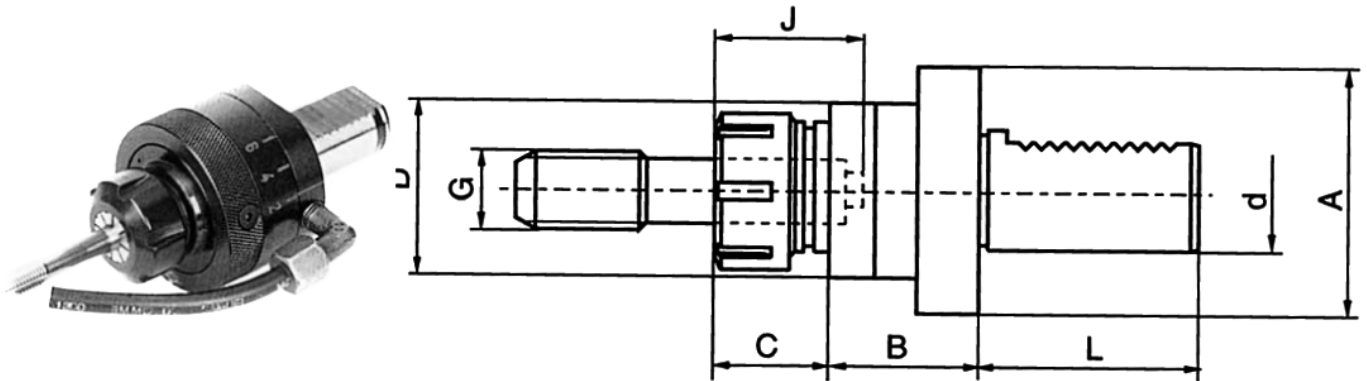

Nr.	Größe Size/Taille	Maße Dimensions d	L	A	D	B	C	J	G
25.595.1	1	16	32	40	32	38	20	34	2-8
25.605.1	1	20	40	50	32	38	20	34	2-8
25.615.1	1	30	55	68	32	40	20	34	2-8
25.595.2	2	16	32	50	50	44	29	41	3-14
25.605.2	2	20	40	50	50	44	29	41	3-14
25.615.2	2	30	55	68	50	46	29	41	3-14
25.625.2	2	40	63	83	50	46	29	41	3-14
25.615.3	3	30	55	70	70	48	29	45	6-20
25.625.3	3	40	63	83	70	48	29	45	6-20
25.635.3	3	50	78	98	70	48	29	45	6-20
25.615.4	4	30	55	85	85	53	34	51	8-27
25.625.4	4	40	63	85	85	53	34	51	8-27
25.635.4	4	50	78	98	85	53	34	51	8-27
25.645.4	4	60	94	120	85	53	34	51	8-27
25.635.6	6	50	78	120	120	67	50	60	12-42
25.645.6	6	60	94	120	120	67	50	60	12-42

Aufbaufansch für Außengewinde

Diebox for external thread Flasque porte fileière

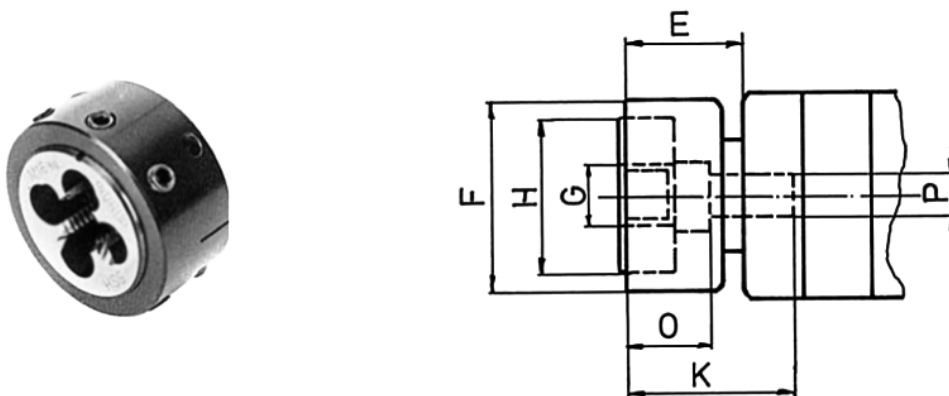

Nr.	Größe Size/Taille	Maße Dimensions E	F	H	K	O	P	G
25.655.1	1	20	32	25	32	16	7	2-8
25.665.2	2	32	49	38	45			3-14
25.655.3	3	34	59	45	52	30	20	6-20
25.655.4	4	42	74	55	62	30	25	8-27

Spannzangen für Gewindebohrer

Collets for Tapping

Pince de serrage pour taraud

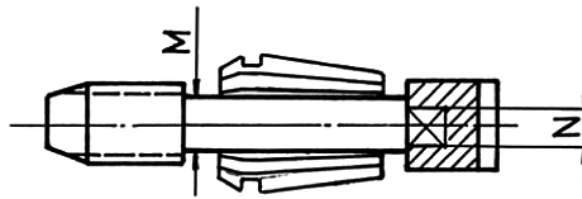

Größe Size/Taille	Nr.	Maß M ø Dimensions
1	120 424E	2,5-2; 3-2,5; 4-3; 5-4; 6-5; 7-6
2	200 428E	4-3; 5-4; 6-5; 7-6; 8-7; 9-8; 10-9; 11-10; 12-11
3	250 430E	5-4; 6-5; 7-6; 8-7; 9-8; 10-9; 11-10; 12-11; 13-12; 14-13; 15-14; 16-15
4	320 470E	7-6; 8-7; 9-8; 10-9; 11-10; 12-11; 13-12; 14-13; 15-14; 16-15; 17-16; 18-17; 19-18; 20-19
6	500 477E	10-8; 12-10; 14-12; 16-14; 18-16; 20-18; 22-20; 24-22; 26-24; 28-26; 30-28; 32-30; 34-32

Bestell-Beispiel:
Spannzange 120 424E = 2,5-2

Sample for ordering:
Collet 120 424E = 2,5-2

Exemple de commande:
pince 120 424E = 2,5-2

Mitnehmer für Gewindebohrer

Drive for Tapping Head

Entraîneur pour taraud

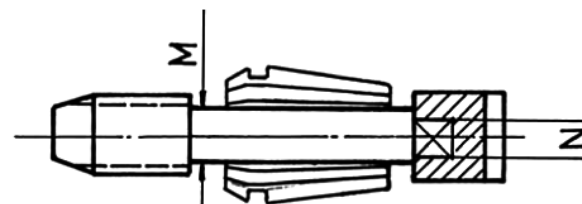

Größe Size/Taille	Nr.	Maß N ø Dimensions N
2	M35-2	2,5; 2,8; 3,15; 3,55; 4; 4,5; 5; 5,6; 6,3; 7,1; 8; 9
3	M35-3	3,15; 3,55; 4; 4,5; 5; 5,6; 6,3; 7,1; 8; 9; 10; 11,2; 12; 12,5
4	M35-4	5; 5,6; 6,3; 7,1; 8; 9; 10; 11,2; 12; 12,5; 14; 14,5; 16
6	M35-6	6,3; 7,1; 8; 9; 10; 11,2; 12; 12,5; 14; 14,5; 16; 18; 20; 22,4; 24; 25; 26

Bestell-Beispiel:
Mitnehmer M35-2; N = 2,5

Sample for ordering:
Drive M35-2; N = 2,5

Exemple de commande:
entraîneur M35-2; N = 2,5

Reduktion und Hinterlegscheibe für Schneideisen

Reductions and Deposit-sheet for Cutting iron

Réduction et rondelle d'épaisseur pour filière

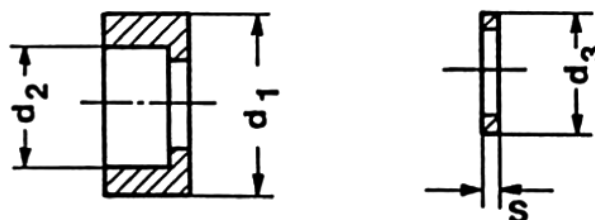

Größe/Sizes/Taille	Größe/Size/Taille
R1 ø 25-20	H1 ø 20 x 1 mm dick
R2 ø 38-30	H2 ø 38 x 2 mm dick
R3 ø 45-38	H3 ø 45 x 2 mm dick
R4 ø 55-45	H4 ø 55 x 3 mm dick

Bestell-Beispiel:
Sample for ordering:
Exemple de commande:

R1 ø 25 x 20
R1 ø 25 x 20
R1 ø 25 x 20

Bestell-Beispiel:
Sample for ordering:
Exemple de commande:

H1 ø 20 x 1
H1 ø 20 x 1
H1 ø 20 x 1

Gewindeschneidfutter mit Längenausgleich auf Druck und Zug

DIN 69 880

Tapping head with tension and compression

DIN 69 880

Mandrin de taraudage à tension et compression

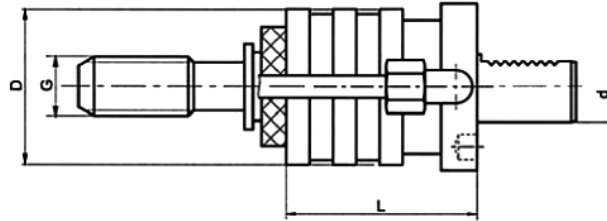

Gewindeschneidfutter

Nr.	Größe	d	D	L	G
25.795.1	1	16	36	52	3-12
25.800.1	1	20	36	58	3-12
25.810.1	1	25	36	50	3-12
25.820.1	1	30	36	62,5	3-12
25.830.1	1	40	36	62,5	3-12
25.840.1	1	50	36	70,5	3-12
25.820.2	2	30	53	87	8-20
25.830.2	2	40	53	87	8-20
25.840.2	2	50	53	104	8-20
25.850.2	2	60	53	104	8-20
25.830.3	3	40	78	122	14-33
25.840.3	3	50	78	108	14-33
25.850.3	3	60	78	108	14-33

Schnellwechsel-Einsätze IG
ohne Sicherheitskupplung zur Aufnahme
von Gewindebohrer

Quick change inserts IG
for taper

Porte-taraud à changement rapide

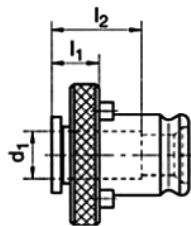

Schnellwechsel-Einsätze AG
zur Aufnahme von Schneideisen

Quick change inserts AG

Porte-filière changement rapide

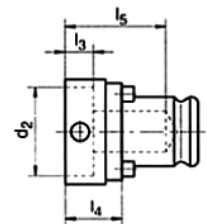

Nr.	Größe	d, Ø	□	l ₁	l ₂
IG 1-2521	1	2,5	2,1	7	17
IG 1-2821	1	2,8	2,1	7	17
IG 1-3125	1	3,15	2,5	7	17
IG 1-3527	1	3,5	2,7	7	17
IG 1-3528	1	3,55	2,8	7	17
IG 1-4030	1	4	3	7	17
IG 1-4031	1	4	3,1	7	17
IG 1-4534	1	4,5	3,4	7	17
IG 1-5040	1	5	4	7	17
IG 1-6049	1	6	4,9	7	17
IG 1-6350	1	6,3	5	7	17
IG 1-7055	1	7	5,5	7	17
IG 1-8062	1	8	6,2	7	17
IG 1-9070	1	9	7	7	17
IG 1-10080	1	10	8	7	17
IG 1-11090	1	11	9	7	17
IG 1-11290	1	11,2	9	7	17
IG 2-6049	2	6	4,9	11	30
IG 2-6350	2	6,3	5	11	30
IG 2-7055	2	7	5,5	11	30
IG 2-8062	2	8	6,2	11	30
IG 2-9070	2	9	7	11	30
IG 2-10080	2	10	8	11	30
IG 2-11090	2	11	9	11	30

Nr.	Größe	d, Ø	□	l ₁	l ₂
IG 2-11290	2	11,2	9	11	30
IG 2-12090	2	12	9	11	30
IG 2-125100	2	12,5	10	11	30
IG 2-140110	2	14	11	11	30
IG 2-140112	2	14	1,2	11	30
IG 2-160120	2	16	12	11	30
IG 2-160125	2	16	12,5	11	30
IG 2-180140	2	18	14	11	30
IG 2-180145	2	18	14,5	11	30
IG 3-11090	3	11	9	14	44
IG 3-11290	3	11,2	9	14	44
IG 3-12090	3	12	9	14	44
IG 3-125100	3	12,5	10	14	44
IG 3-140110	3	14	11	14	44
IG 3-140112	3	14	11,2	14	44
IG 3-160120	3	16	12	14	44
IG 3-160125	3	16	12,5	14	44
IG 3-180140	3	18	14	14	44
IG 3-180145	3	18	14,5	14	44
IG 3-200160	3	20	16	14	44
IG 3-220180	3	22	18	14	44
IG 3-224180	3	22,4	18	14	44
IG 3-250200	3	25	20	14	44
IG 3-280220	3	28	22	14	44

Nr.	Größe	d ₂	l ₃	l ₄	l ₅
AG 1-1605	1	16	4,8	14	28
AG 1-2005	1	20	4,8	14	28
AG 1-2007	1	20	6,5	16	30
AG 1-2509	1	25	8,5	19	33
AG 1-3011	1	30	10	21	35
AG 1-3810	1	38	9	20	34
AG 1-3814	1	38	13	24	38
AG 2-2005	2	20	4,8	20	55
AG 2-2007	2	20	6,5	21,5	56
AG 2-2509	2	25	8,5	23,5	55
AG 2-3011	2	30	10	22	57
AG 2-3810	2	38	9	21	56
AG 2-3814	2	38	13	25	60
AG 2-4514	2	45	13	25	60
AG 2-4518	2	45	17	35	64
AG 3-3011	3	30	10	30	85
AG 3-3810	3	38	9	28	83
AG 3-3814	3	38	13	32	87
AG 3-4514	3	45	13	32	87
AG 3-4518	3	45	17	36	91
AG 3-5516	3	55	15	30	85
AG 3-5522	3	55	20	35	90
AG 3-6518	3	65	17	32	87
AG 3-6525	3	65	23	38	93

Gewindeschneidfutter mit Längenausgleich auf Druck und Zug

mit Zylinderschaft

Tapping head with tension and

with cylindr. shank

Mandrin de taraudage à extension et compression

queue cylindrique

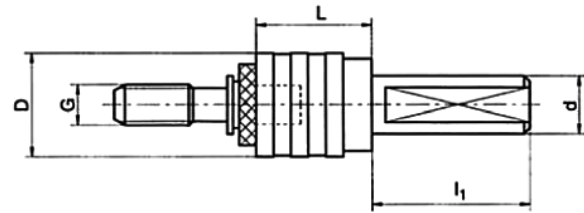

Bestell Nr.	Order No.	Größe	d	l ₁	L	D	G
WFLK 1/16		1	16	56	39	36	M3-M12
WFLK 1/25		1	25	48	41	35	M3-M12
WFLK 2/25		2	25	48	64	53	M8-M20

Pendelhalter für RD/ER Spannzangen

mit Zylinderschaft
für Werkzeuge mit äußerer oder innerer Kühlmittelzufuhr

Floating Toolholder with RD/ER collets

with cylindr. shank
for ols with internal or external coolant

Porte outil pendule avec RD/ER pince RD/ER

queue cylindrique
arrosage interne-externe

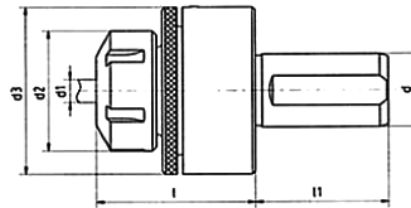
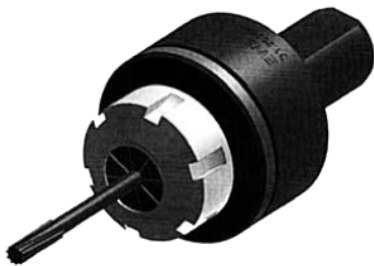

Bestell-Nr.	Order No.	d	l	l ₁	d ₁	d ₂	d ₃	passende Spannzangen
PH31.1611-ZYL		16	40	46	1-7	19	42	110 4008 E
PH31.1616-ZYL		16	48,5	44	2-10	32	45	160 426 E
PH31.1620-ZYL		16	50	44	2-13	35	50	200 426 E
PH31.2011-ZYL		20	40	46	1-7	19	42	110 4008 E
PH31.2016-ZYL		20	48,5	45	2-10	32	45	160 426 E
PH31.2020-ZYL		20	50	45	2-13	35	50	200 426 E
PH31.2025-ZYL		20	57	45	2-16	42	58	250 430 E
PH31.2520-ZYL		25	50	45	2-13	35	50	200 428 E
PH31.2525-ZYL		25	57	46	2-16	42	58	250 430 E
PH31.25,4/25-ZYL		25,4	57	46	2-16	42	58	250 430 E
PH31.2532-ZYL		25	62	46	3-20	50	68	320 470 E
PH31.3225-ZYL		32	57	55	2-16	42	58	250 430 E
PH31.3232-ZYL		32	62	55	3-20	50	68	320 470 E
PH31.4025-ZYL		40	57	65	2-16	42	68	250 430 E
PH31.4032-ZYL		40	62	65	3-20	50	68	320 470 E

Externe Kühlung - durch Spannzangenschlitze
Interne Kühlung - durch Werkzeug mit abgedichteter Spannzange

External cooling - through collet slits
Internal cooling - with sealed collet

Arrosage extérieur à travers les fentes de la pince
Arrosage intérieur avec les princes étanches

Aufnahme DIN 69380

Adaptor

Adaptateur porte-outil

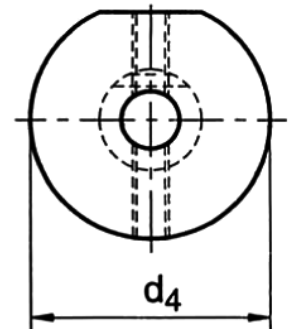
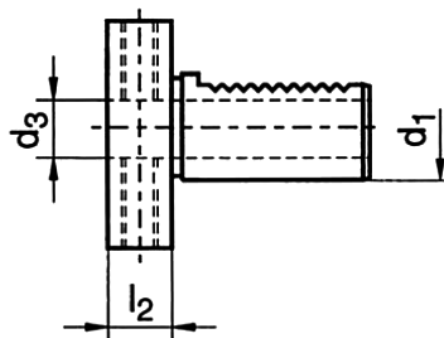

Bestell Nr.	Order No.	d ₁	d ₂	d ₃	l ₂
33.3016		30	16	68	13
33.4025		40	25	83	13

Pendelhalter für RD/ER Spannzangen

DIN 69 880 VDI 3425 Bl. 2
Für Werkzeuge mit äußerer oder innerer Kühlmittelzufuhr

Floating Toolholder with RD/ER collets

DIN 69 880 VDI 3425 Sheet 2
for tools with internal or external coolant

Porte outil pendule avec RD/ER pinse de serrage

DIN 69 880 VDI 3425 page 2
outil à arrosage interne

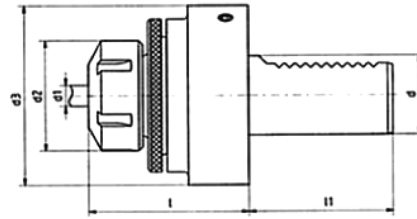

Best. Nr. Order No.	d	l	l ₁	d ₁	d ₂	d ₃	passende Spannzangen
PH31.1616-VDI	16	57	32	2-10	32	45	160 426 E
PH31.1620-VDI	16	59	32	2-13	35	50	200 428 E
PH31.2016-VDI	20	57	40	2-10	32	50	160 426 E
PH31.2020-VDI	20	59	40	2-13	35	50	200 428 E
PH31.2525-VDI	25	63	48	2-16	42	58	250 430 E
PH31.3025-VDI	30	63	55	2-16	42	68	250 430 E
PH31.3032-VDI	30	71	55	3-20	50	68	320 470 E
PH31.3040-VDI	30	75	55	4-26	63	80	400 472 E
PH31.4025-VDI	40	63	63	2-16	42	83	250 430 E
PH31.4032-VDI	40	71	63	3-20	50	83	320 470 E
PH31.4040-VDI	40	75	63	4-26	63	83	400 472 E
PH31.5032-VDI	50	71	78	3-20	50	98	320 470 E
PH31.6032-VDI	60	71	94	3-20	50	123	320 470 E

Externe Kühlung - durch Spannzangenschlitze
Interne Kühlung - durch Werkzeug mit abgedichteter Spannzange

External cooling - through collet slits
Internal cooling - with sealed collet

Arrosage extérieur à travers les fentes de la pince
Arrosage intérieur avec les princes étanches

Stangengreifer

Bar pick up

tire - barre

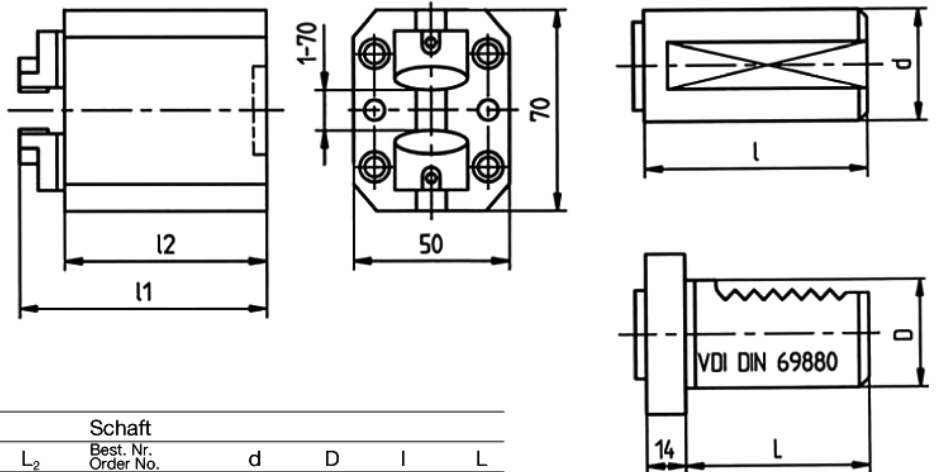
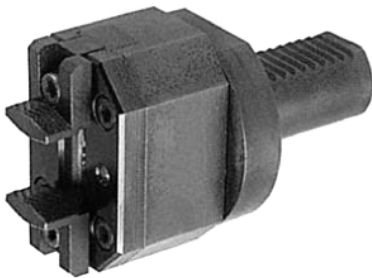

Stangengreifer Best. Nr.	Stangengreifer					Schaft				
	A	B	C	L ₁	L ₂	Best. Nr. Order No.	d	D	l	L
SG-10	70	50	2-70	78	61	SGS-20 - ZYL	Ø20	--	63	--
SG-10	70	50	2-70	78	61	SGS-25 - ZYL	Ø25	--	63	--
SG-10	70	50	2-70	78	61	SGS-30 - ZYL	Ø30	--	63	--
SG-10	70	50	2-70	78	61	SGS-32 - ZYL	Ø32	--	63	--
SG-10	70	50	2-70	78	61	SGS-40 - ZYL	Ø40	--	63	--
SG-10	70	50	2-70	78	61	SGS-50 - ZYL	Ø50	--	63	--
SG-10	70	50	2-70	78	61	SGS-50 - ZYL	Ø50	--	63	--
SG-09	50	42	2-42	54	40	SGS-16 - VDI	--	16	--	32
SG-09	50	42	2-42	54	40	SGS-20 - VDI	--	20	--	40
SG-09	50	42	2-42	54	40	SGS-25 - VDI	--	25	--	48
SG-11	70	50	2-70	58	41	SGS-30 - VDI	--	30	--	55
SG-11	70	50	2-70	58	41	SGS-40 - VDI	--	40	--	63
SG-11	70	50	2-70	58	41	SGS-50 - VDI	--	50	--	78

Stangengreifer

DIN 69 880 VDI 3425 Bl. 2
rechts

Bar pick-up

DIN 69 880 VDI 3425 Sheet 2
right hand

Preneur pour barre

DIN 69 880 VDI 3425 page 2
droite

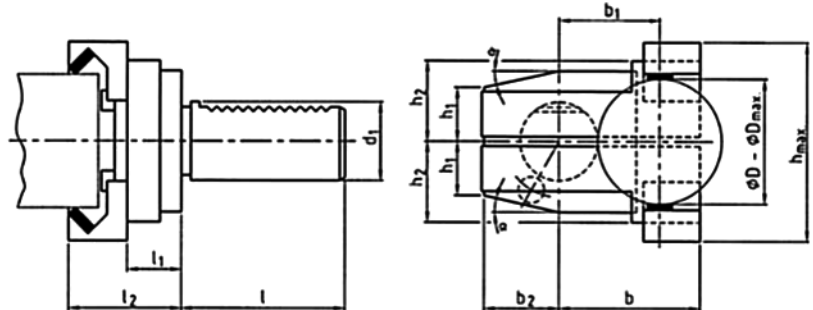
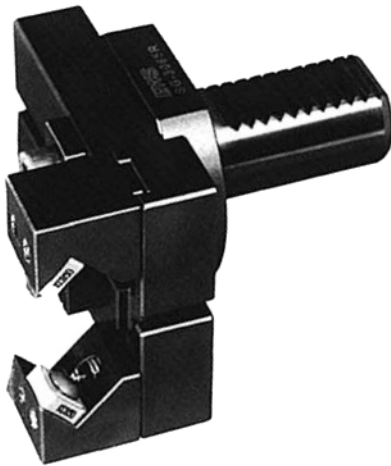

1

Bestell Nr. Order No.	d_1	L	l_1	l_2	b	b_1	b_2	D	Sonderzubehör Special accessories	h	h_1	α	h_2
SG-1636 R	16	32	28	53	35	28	26,5	2-22	GRA-36	74	12,5	15	28
SG-2042 R	20	40	34	59	61	54	36,5	2-42		85	17	15	38
SG-2565 R	auf Anfrage / on request / sur demand												
SG-3065 R	30	55	34	59/63	61	54	37	2-42	GRA-65	105	27		38
SG-4085 R	40	63	34	59/63	61	54	41,5	2-65	GRA-85	125	27		38
SG-5085 R	50	78	34	59/63	61	54	49	2-65	GRA-85	125	32		38

links / left hand / gauche

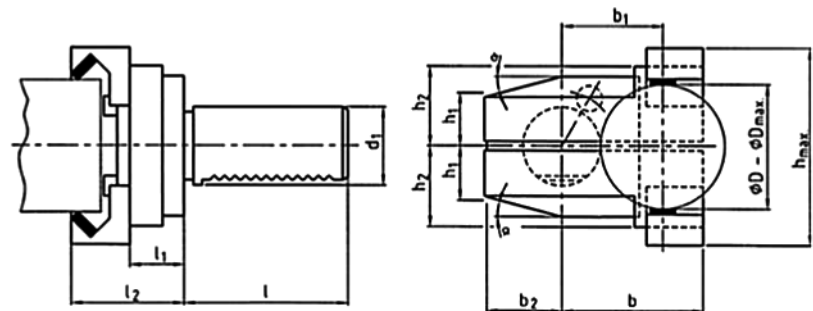

Bestell Nr. Order No.	d_1	L	l_1	l_2	b	b_1	b_2	D	Sonderzubehör Special accessories	h	h_1	h_2
SG-3065 L	30	55	34	59/63	61	54	37	2-42	GRA-65	105	27	38
SG-4085 L	40	63	34	59/63	61	54	41,5	2-65	GRA-85	125	27	38

Sonderzubehör und Ersatzteile
Greifer-Aufsätze

Bestell Nr.
Order No.

D	nmax	für / for / pour
2-22	68	SG-1636 R
18-36	74	SG-1636 R
2-42	85	SG-2042 R / SG-3065 R/L / SG-4085 R/L / SG-5085 R
42-65	105	SG-3065 R/L / SG-4085 R/L / SG-5085 R
62-85	125	SG-4085 R/L / SG-5085 R

Hartmetall-Platte
Hard-metal-plate
plaquette en carbure

Bestell Nr.
Order No.

HP-1305
HP-1305
HP-1305
HP-1305
HP-1305

Mitlaufende Zentrierspitze

Driver centering point

Pointe de centrage entraînée

DIN 69 880

VDI 3425 Bl. 2

DIN 69 880

VDI 3425 Sheet 2

DIN 69 880

VDI 3425 page 2

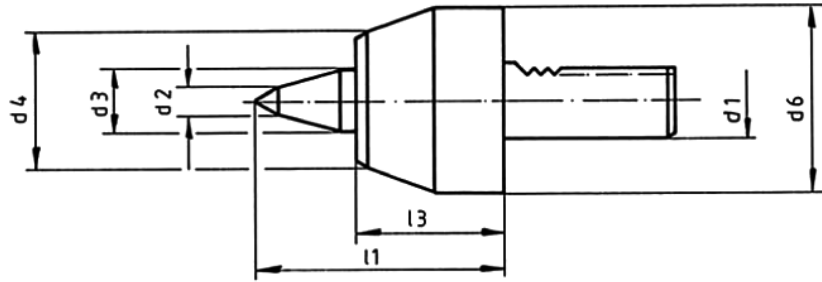

Nr.	d ₁	d ₂	d ₃	d ₄	d ₆	l ₁	l ₃
4720020	20	6	18	41	50	73	42
4720030	30	11	22	47	67	88	51
4720040	40	16	32	56	83	111	63

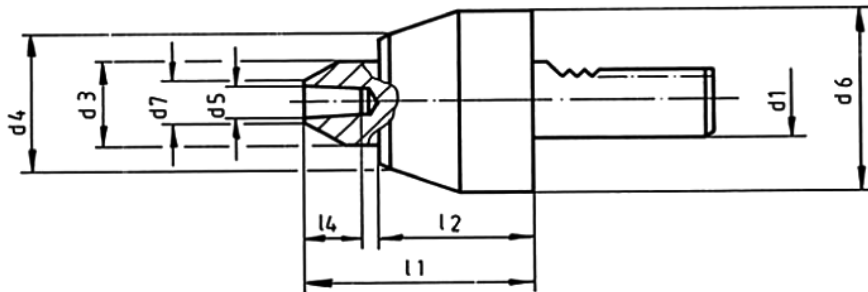

Nr.	d ₁	d ₃	d ₄	d ₅	Kegel 1:10	d ₆	d ₇	l ₁	l ₂	l ₄
4760020	20	18	41	7		50	12	73	64	20
4760030	30	22	47	12		67	18	88	76	24
4760040	40	32	56	12		83	18	111	96	27

Zentriereinsätze

Centering inserts

Inserts de centrage

Type 100

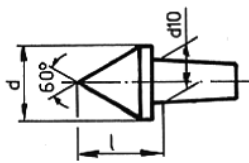

Type 400

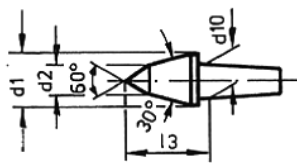

Type 200

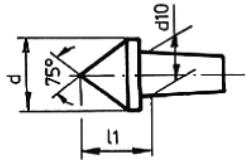

Type 500

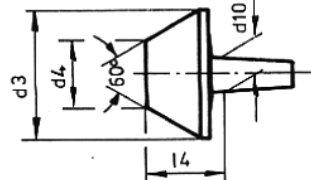

Type 300

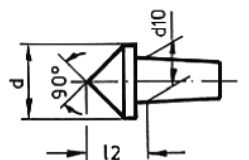

Type 600

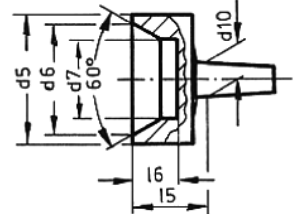

zu DIN 69 880 Ø	20	30	40
d	16	20	24
d ₁	14	18	18
d ₂	6	8	8
d ₃	25	35	45
d ₄	10	15	25
d ₅	25	35	45
d ₆	20	30	40
d ₇	10	15	25
d ₁₀ Kegel 1:10	7	12	12
l	20	24	27,5
l ₁	17	19,5	22,5
l ₂	14,5	16,5	19
l ₃	25	30	30
l ₄	21	26	27
l ₅	18	24	25
l ₆	11	16	16

Type	Nr.		
100	4061002	4061003	4061004
200	4062002	4062003	4062004
300	4063002	4063003	4063004
400	4064002	4064003	4064004
500	4065002	4065003	4065004
600	4066002	4066003	4066004
Austreiber	4067002	4067003	4067004

Rändel-Fräswerkzeuge

Knurting tool

Outil a moletter

DIN 69 880 VDI 3425 Bl. 2

DIN 69 880 VDI 3425 Sheet 2

DIN 69 880 VDI 3425 page 2

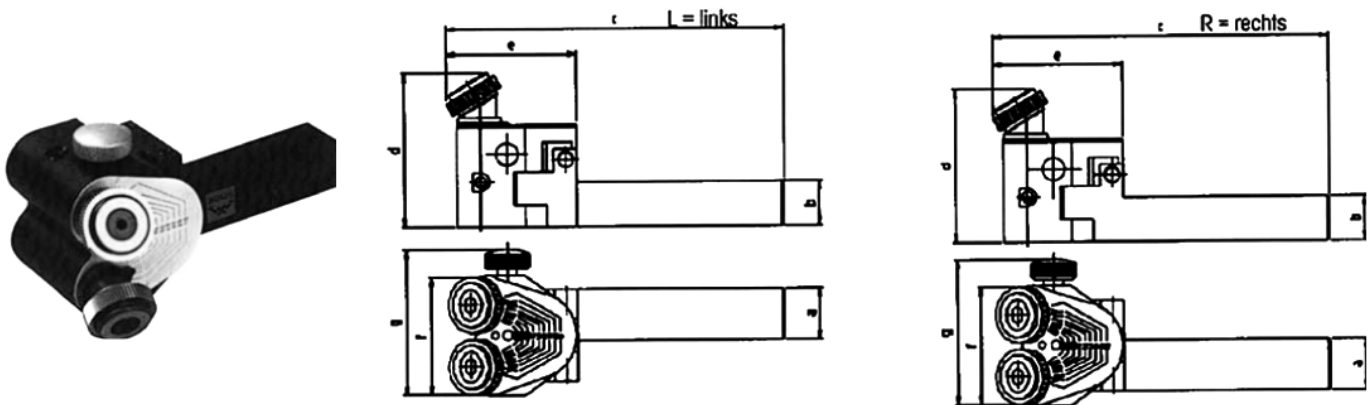

Bestell-Nr. komplett	Bestell-Nr. 1 Schaft	Bestell-Nr. 2 Rändelfräskopf	Arbeitsbereich xmm	Rändel-fräsrollen								
				a	b	c	d	e	f	g		
241-16M 150 408	21BHR0439	21BHR0513	3-50	16	20	115	40	35	34	39	15x4x8	
241-20M 150 408	21BHR0012	21BHR0513	3-50	20	20	115	40	35	34	39	15x4x8	
241-25M 150 408	21BHR0441	21BHR0513	3-50	25	20	115	40	35	34	40	15x4x8	
241-20M 250 608	21BHR0029	21BHR0518	10-250	20	20	138	70	58	58	64	25x6x8	
241-25M 250 608	21BHR0363	21BHR0518	10-250	25	25	138	70	58	58	64	25x6x8	

Rändelfräskrollen

Bestell-Nr.	d ₂	Rändelmutter	Teilung
15x4x8BL15/BR15	15	Kreuz	0,4/0,5/0,6/0,8/1,0/1,2
25x4x8BL15/BR15	25	Kreuz	0,4/0,5/0,6/0,8/1,0/1,2/1,5/1,6/2,0
15x4x8AA	15	Fischhaut	0,4/0,5/0,6/0,8/1,0/1,2
25x6x8AA	25	Fischhaut	0,4/0,5/0,6/0,8/1,0/1,2/1,5/1,6/2,0

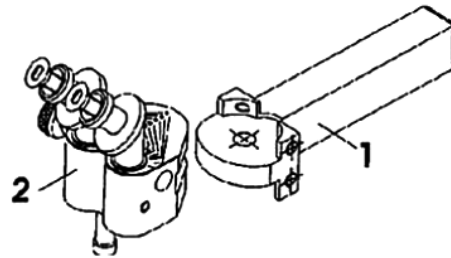

Verschlussstopfen

Plug

Bouchon de protection

wahlweise aus Stahl oder Kunststoff

made either from steel or plastic

acier ou plastique

DIN 69 880 VDI 3425 Bl. 2 Form Z2

DIN 69 880 VDI 3425 Sheet 2 Form Z2

DIN 69 880 VDI 3425 page 2 Form Z2

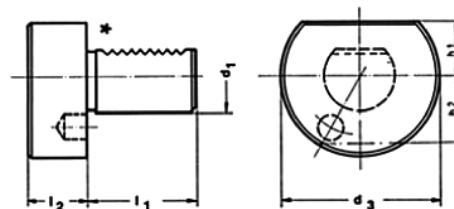

Bestell Nr.	d ₁	d ₃	h ₁	h ₂	l ₁	l ₂
29.16	16	40	18	23	32	13
29.20	20	50	23	23	40	16
29.25	25	58	25	25	48	16
29.30	30	68	28	30	55	16
29.40	40	83	32,5		63	20
29.50	50	98	35		78	20
29.60	60	123	42,5		78	20
29.80	80	158	55		124	20

Im Bestellfalle bei

Stahl

Kunststoff

Kunststoff verstärkt

Bestell Nr. mit Zusatz "S"

Bestell Nr. mit Zusatz "K"

Bestell Nr. mit Zusatz "KV"

When ordering

in steel

in plastic

in plastic /strong vers.)

order no + add "S"

order no + add "K"

order no + add "KV"

Lors de la commande

specifier en plus de la référence S pour bouchon acier

Einrichtehalter

Setting-Holder

Porte-outil de réglage

DIN 69 880

VDI 3425 Bl. 2

DIN 69 880

VDI 3425 Sheet 2

DIN 69 880

VDI 3425 page 2

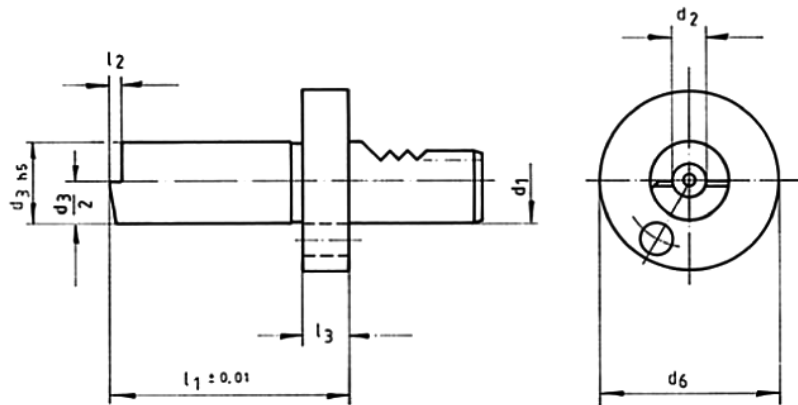

Nr.	d ₁	d ₁	d ₃	d ₆	l ₁	l ₂	l ₃
E16.30.100	16	20	30	40	100	8	15
E20.40.100	20	20	40	50	100	8	15
E25.40.100	25	20	40	58	100	8	15
E30.40.100	30	20	40	68	100	8	15
E40.40.100	40	20	40	83	100	8	15
E50.40.100	50	20	40	98	100	8	15
E60.40.100	60	20	40	123	100	8	15

Prüfdorn

Test mandrel

Mandrin de contrôle

DIN 69 880

VDI 3425 Bl. 2

DIN 69 880

VDI 3425 Sheet 2

DIN 69 880

VDI 3425 page 2

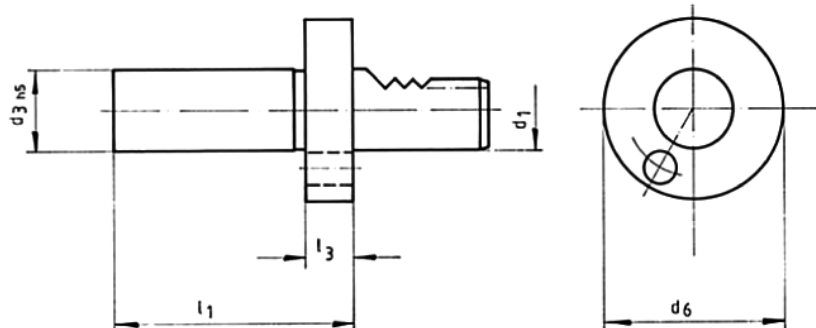

Nr.	d ₁	d ₃	d ₆	l ₁	l ₃
P16.30.120	16	30	40	120	15
P20.40.150	20	40	50	150	15
P25.40.150	25	40	58	150	15
P30.40.200	30	40	68	200	15
P40.40.200	40	40	83	200	15
P50.40.200	50	40	98	200	15
P60.40.200	60	40	123	200	15

Etuis



Nr.	für	Nr.	für
HKE16	E16.30.100	HKP16	P16.30.120
HKE20	E20.40.100	HKP20	P20.40.150
HKE25	E25.40.100	HKP25	P25.40.150
HKE30	E30.40.100	HKP30	P30.40.200
HKE40	E40.40.100	HKP40	P40.40.200
HKE50	E50.40.100	HKP50	P50.40.200
HKE60	E60.40.100	HKP60	P60.40.200

Spannzangenanschlag
für Werkstückspannung

Collets stop
for workpiece clamping

Pince arrêt
pour tension d'ouvrage

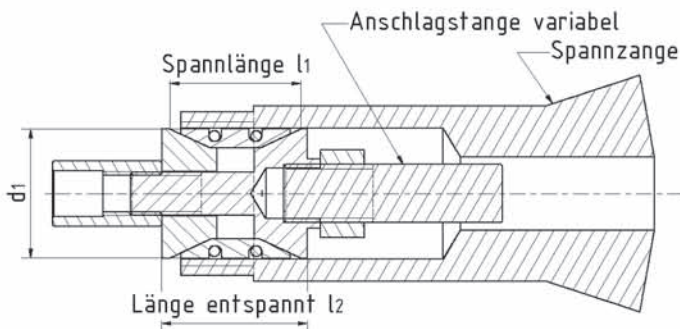

Nr.	Spann Ø d1	Spannlänge l1	Länge entspannt l2
ZA 9	9-11	16	27
ZA11	11-13	17	28
ZA13	13-15	20	32
ZA15	15-17	22	34
ZA17	17-20	24	37
ZA20	20-24	28	40
ZA24	24-30	30	43
ZA30	30-36	30	43
ZA36	36-42	30	43
ZA42	42-48	30	43
ZA48	48-54	30	43
ZA54	54-61	30	44

1

Spannzangenanschlag für Druckspannzangen
Reihe 100

Back stop for Push-outcollets
Series 100

Arrêt Pur pincey poussées
Série 100

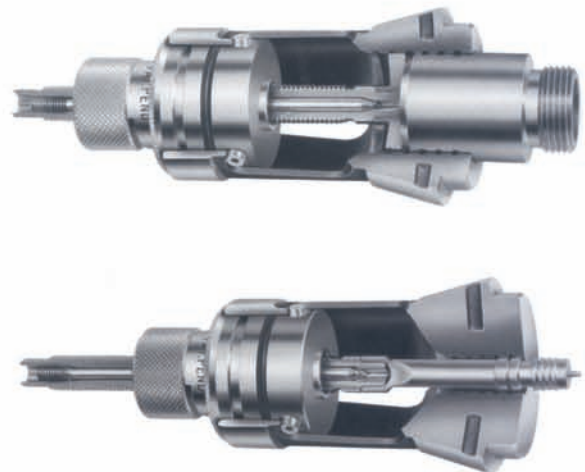

Nr.	Für Spannzangen
ASF-32/32 161 0000	161E
ASF-35/35 162 0000	162E/163E
ASF-38/38 164 0000	164E
ASF-48/48 173 0000	173E
ASF-66/66 185 0000	185E

SE-Spannelemente

zum Ausdrehen von weichen Backen
in Spannfutter

SE-Gripping-element

for turning of soft flanges
in the sleeve

Élément de serrage SE

Pour le tournage des mors doux
en porte - pince

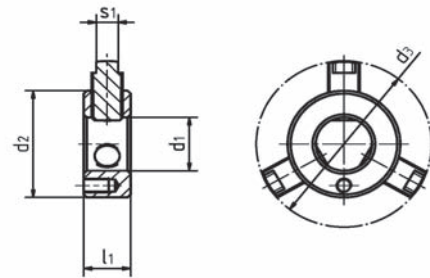

Type	Nr.	Maße/Dimensions				
		s ₁	d ₁	d ₂	d _{3max}	l ₁
SE1	600.101	7	11	24	34	15
SE2	600.102	7	14	30	44	15
SE3	600.103	7	18	36	56	15
SE4	600.104	7	24	52	84	15
SE5	600.105	7	45	76	130	15
SE6	600.106	7	80	124	178	15

Spannelemente mit weiterem d₂ und
d₃ Maßen auf Anfrage

Gripping element with further d₂ and
d₃ measurements on request

Élément de serrage avec autre dimension
pour d₂ ou d₃ sur demande

Bolzen

Nr.	Maße/Dimensions	
	d ₄	l ₂
600.110	6	115

Bolts

Clé de montage

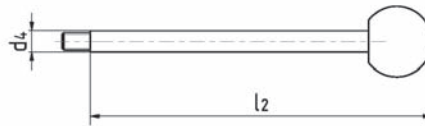

LA-Längenanschlag

für Drehmaschinen
ohne Kraftspanneinrichtung

LA-Length Back stop

for turning machines
without hydraulic clamping

LA-Long arrêt

pour Tourmachines
sans tensionhydraulique

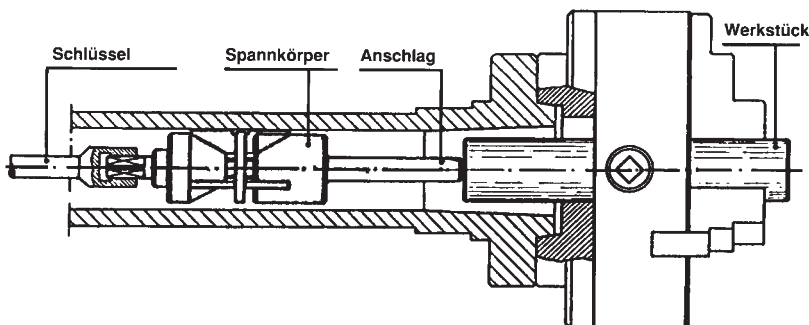

Nr.	Spanndurchmesser in mm
LA 20.23	20-23
LA 23.27	23-27
LA 27.31	27-31
LA 31.39	31-39
LA 39.47	39-47
LA 47.57	47-57
LA 57.65	57-65
LA 65.78	65-78
LA 78.94	78-94
LA 94.110	94-110
LA 110.130	110-130





Prismenaufnahmen nach DIN 69881

Dove tail tool holder according to DIN 69881
Porte-outils prismatiques conforme DIN 69881

DIN 69 881 VDI 3425 / 3

Werkzeughalter mit Prisma
Toolholder with Dove Tail Clamp
Porte-outil prismatique

			Form	Page
Radial-Werkzeughalter Axial-Werkzeughalter	Radial-Tool holder Axial-Toolholder	Porte-outil radial Porte-outil axial	A1 / A2 B1 / B2	2.1
Mehrfach Werkzeughalter	Multi-Tool holder	Porte-outil multiple	C1 - C3	2.2 / 2.3 /2.6
Bohrstangenhalter	Boring bar holder	Porte-barre d'alésage	D1 - D3	2.3 / 2.4
Kühlmittelverteiler	Coolant Distributer	Conduit d'arrosage		2.5
Stellhülsen	Automotive Shank holders	Porte-outil réglable		2.5 - 2.5
Doppel-Bohrstangenhalter Werkzeughalterplatten	Twin boring bor holder Tool holder adaptor Plates	Porte-barre pour outil à plaquettes carbure		2.7
Bohrhalter für Wendeplattenbohrer	Boring Bar for Carbide tipped Tools	Porte-barre pour outil à plaquettes		2.8 / 2.9
Werkzeughalter für kleine Borstangen höhenverstellbar	Toolholders, Height adjustable for small Boring Bars	Porte-barre réglable en hauteur pour petit diamètre		2.10
Aufnahmehülsen	Sleeves	Douilles		2.11 / 2.12
Kegelaufnahmen	Morse Taper Shank holder	Porte-outil pour queue à cône Morse		2.13
Spannzangengutter	Collet Chucks	Porte-pinces		
Stellhülsen	Morse Taper Shank holder	Porte-outil pour embout réglable		2.14
MK Reduzierhülsen	Collet Chuck	Douille de réduction		

Vierkant-Queraufnahme

Turning Toolholder

Radial-Porte outil

DIN 69881 Teil 2 VDI 3425 Bl. 3
Form A

DIN 69881 Part 2 VDI 3425 Sheet 3
Form A

DIN 69881 Partie 2 VDI 3425 page 3
Forme A

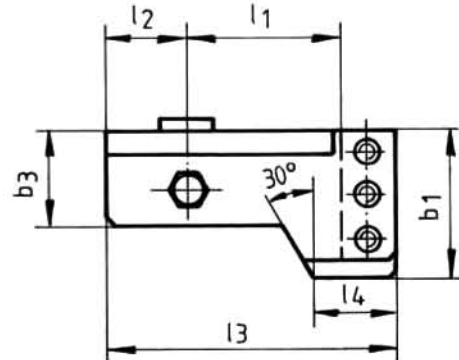
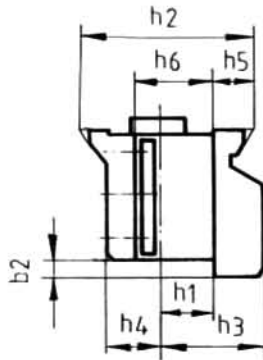

Form
A2 Rechte Ausführung (wie gezeichnet)
A1 Ausführung links (spiegelbildlich)

Form
A2 Right side (as drawn)
A1 Left side (mirror image)

Forme
A2 Exécution droite dessin ci-dessus
A1 Exécution gauche dessin inverse

Nenngröße h ₁ Size Taille	Nr. Rechts Right Droite	Nr. Links Left Gauche	Maße/Dimensions											
			h ₂	b ₁	b ₂	b ₃	h ₃	h ₄	h ₅ ± 0,05	h ₆ max.	l ₁ +0,5 0	l ₂	l ₃	l ₄
16	10.100	10.101	56	50	6	32	40	19	12	22	49	31	94	34
20	10.110	10.111	72	63	6	40	43	27	16	29	49	39	110	45
25	10.120	10.121	90	72	9	40	50	35,5	20	34	73	39	138	45
32	10.130	10.131	115	85	9	50	60	40	25,5	41	112	49	191	50
40	10.140	10.141	140	110	12	60	78	57,5	30	53	115	59	209	55

2

Vierkant-Längsaufnahme

Turning Toolholder for Square Tool

Axial-Porte outil

DIN 69881 Teil 3 VDI 3425 Bl. 3

DIN 69881 Part 3 VDI 3425 Sheet 3

DIN 69881 Partie 3 VDI 3425 page 3

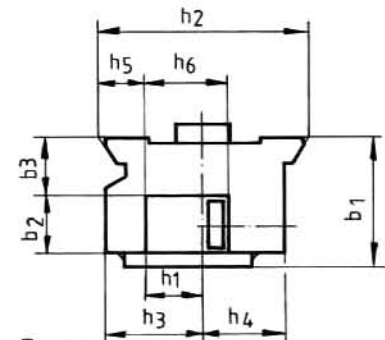
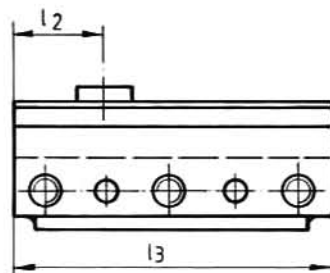

Form
B2 Linke Ausführung (wie gezeichnet)
B1 Ausführung rechts (spiegelbildlich)

Form
B2 Left side (as drawn)
B1 Right side (mirror image)

Forme
B2 Exécution droite dessin ci-dessus
B1 Exécution gauche dessin inverse

Nenngröße h ₁ Size Taille	Nr. Rechts Right Droite	Nr. Links Left Gauche	Maße/Dimensions									
			h ₂	b ₁	b ₂	b ₃ +0,5 0	h ₃	h ₄	h ₅ ± 0,05	h ₆ max.	l ₂	l ₃
16	10.150	10.151	56	39	20	16	26	19	12	22	31	94
20	10.160	10.161	72	47	26	16	34	27	16	29	39	110
25	10.170	10.171	90	49	26	18	42,5	35,5	20	34	39	118
32	10.180	10.181	115	56	33	18	55	40	25,5	41	49	123
40	10.190	10.191	140	67	42	20	67,5	57,5	30	53	59	160

Vierkant-Mehrfachaufnahme

DIN 69881 Teil 4 VDI 3425 Bl. 3
Form C

Multi Purpose Square Toolholder

DIN 69881 Part 4 VDI 3425 Sheet 3
Form C

Radial-Porte outil carré universelle

DIN 69881 Partie 4 VDI 3425 page 3
Forme C

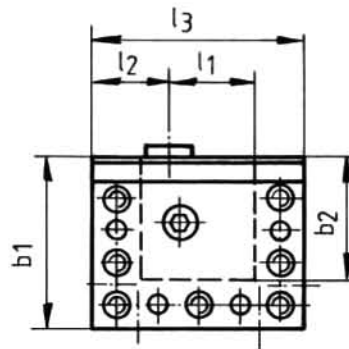

Ausführung A

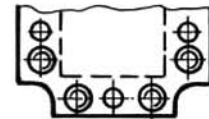
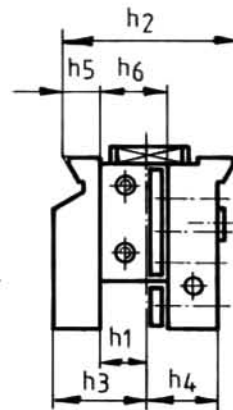

Ausführung B

Form C2 Linke Ausführung (wie gezeichnet)
C1 Ausführung rechts (spiegelbildlich)

Form C2 Left side (as drawn)
C1 Right side (mirror image)

Forme C2 Exécution droite dessin ci-dessus
C1 Exécution gauche dessin inverse

Nenngröße h ₁ Size Taille	Nr. Rechts Right Droite	Nr. Links Left Gauche	Maße/Dimensions									
			h ₂	b ₁	b ₂ +0,5 0	h ₃	h ₄	h ₅ ± 0,05	h ₆ max.	l ₁ +0,5 0	l ₂	l ₃
16	10.200	10.201	56	60	46	40	19	12	22	39	31	84
20	10.210	10.211	72	81	59	43	27	16	29	37	39	98
25	10.220	10.221	90	88	62	50	35,5	20	34	43	39	108
32	10.230	10.231	115	94	68	60	40	25,5	41	43	49	118
40	10.240	10.241	140	115	83	78	57,5	30	53	53	59	144

Vierkant-Mehrfachaufnahme schmal

DIN 69881 Teil 4 VDI 3425 Bl. 3
Form C3

Multi Purpose Square Toolholder narrow

DIN 69881 Part 4 VDI 3425 Sheet 3
Form C3

Radial-Porte outil carré étroit

DIN 69881 Partie 4 VDI 3425 page 3
Forme C3

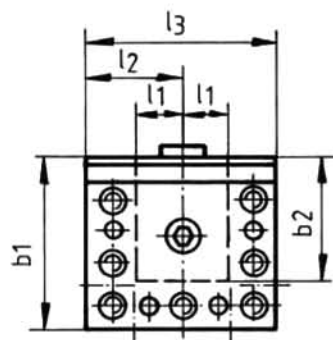

Ausführung A

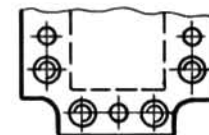
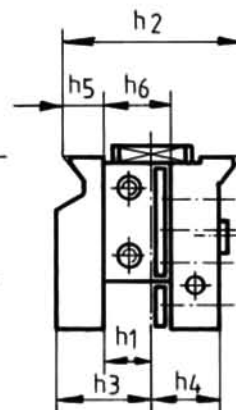

Ausführung B

Nenngröße h ₁ Size Taille	Nr.	Maße/Dimensions									
		h ₂	b ₁	b ₂ +0,5 0	h ₃	h ₄	h ₅ ± 0,05	h ₆ max.	l ₁ +0,5 0	l ₂	l ₃
16	10.250	56	60	46	40	19	12	22	17	31	62
20	10.260	72	81	59	43	27	16	29	17	39	78
25	10.270	90	88	62	50	35,5	20	34	23	49	98
32	10.280	115	94	68	60	40	25,5	41	23	49	98
40	10.290	140	115	83	78	57,5	30	53	27	59	118

**Doppel-Radial-
Werkzeughalter**

Double-Radial-Toolholder

Radial-Porte outil double

DIN 69881 VDI 3425 Bl. 3

DIN 69881 VDI 3425 Sheet 3

DIN 69881 VDI 3425 page 3

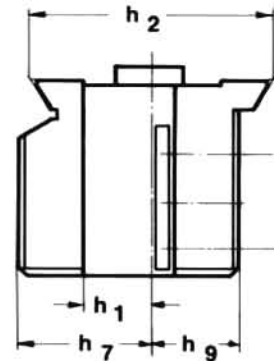
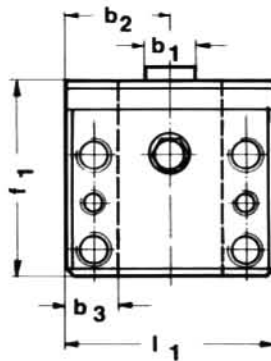

Nenngröße h ₁ Size Taille	Nr.	Maße/Dimensions							
		b ₁	b ₂	b ₃	h ₂	h ₇	h ₉	f ₁	l ₁
16	10.300	16	34	16	56	40	19	60	68
20	10.310	20	39	22	72	43	27	81	78
25	10.320	25	39	25	90	50	35,5	88	78
32	10.330	25	49	26	115	60	40	94	98
40	10.340	25	59	32	140	78	57,5	115	118

2

Zylinderaufnahme

Side Lock Adaptor

Porte outil cylindrique

DIN 69881 Teil 5 VDI 3425 Bl. 3
Form D3

DIN 69881 Part 5 VDI 3425 Sheet 3
Form D3

DIN 69881 Partie 5 VDI 3425 page 3
Forme D3

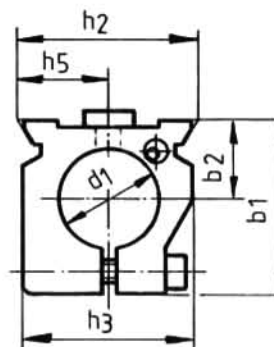
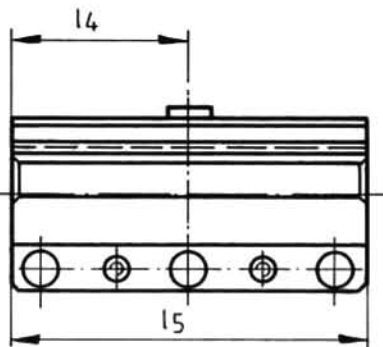
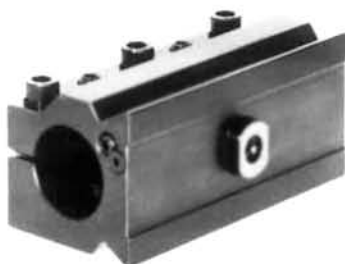

Nenngröße Size Taille	Nr.	Maße/Dimensions							
		h ₂	d ₁ H7	b ₁	b ₂	h ₃	h ₅	l ₄	l ₅
16	10.350	56	32	65	30	52	28	59	118
20	10.360	72	40	76	35	68	36	75	150
25	10.370	90	50	94	45	85	45	99	198
32	10.380	115	60	94	45	93	57,5	99	198
40	10.390	140	80	125	60	115	70	119	238

Nenngröße Size Taille	Nr.	Maße/Dimensions							
		h ₂	d ₁ H7	b ₁	b ₂	h ₃	h ₅	l ₄	l ₅
16	10.355	56	40	65	30	52	28	59	118
20	10.365	72	50	76	35	68	36	75	150
25	10.375	90	60	94	45	85	45	99	198
32	10.385	115	80	115	55	115	57,5	99	198
40	10.395	140	100	145	70	135	70	119	238

Zylinderaufnahme

kurz

DIN 69881 Teil 5 VDI 3425 Bl. 3
Form D

Side Lock Adaptor

short

DIN 69881 Part 5 VDI 3425 Sheet 3
Form D

Porte outil cylindrique

court

DIN 69881 Partie 5 VDI 3425 page 3
Forme D

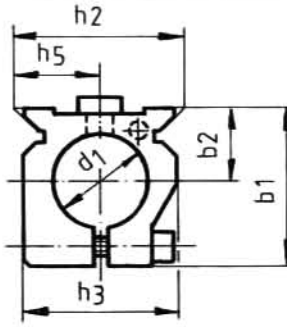
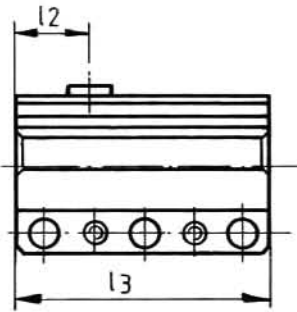

Form

D2 Rechte Ausführung (wie gezeichnet)
D1 Ausführung links (spiegelbildlich)

Form

D2 Right side (as drawn)
D1 Left side (mirror image)

Forme

D2 Exécution droite dessin ci-dessus
D1 Exécution gauche dessin inverse

Nenngröße Size Taille	Nr. Rechts Right Droite	Nr. Links Left Gauche	Maße/Dimensions							
			h_2	d_1 H7	b_1	b_2	h_3	h_5	l_2	l_3
16	10.400	10.401	56	32	65	30	52	28	31	94
20	10.410	10.411	72	40	76	35	68	36	39	110
25	10.420	10.421	90	50	94	45	85	45	39	138
32	10.430	10.431	115	60	94	45	93	57,5	49	148
40	10.440	10.441	140	80	125	60	115	70	59	178

Nenngröße Size Taille	Nr. Rechts Right Droite	Nr. Links Left Gauche	Maße/Dimensions							
			h_2	d_1 H7	b_1	b_2	h_3	h_5	l_2	l_3
16	10.450	10.451	56	40	65	30	52	28	31	94
20	10.460	10.461	72	50	76	35	68	36	39	110
25	10.470	10.471	90	60	94	45	85	45	39	138
32	10.480	10.481	115	80	94	55	115	57,5	49	148
40	10.490	10.491	140	100	125	70	135	70	59	178

Bohrstangenhalter

DIN 69881 VDI 3425 Bl. 3

Boring Bar Holder

DIN 69881 VDI 3425 Sheet 3

Porte barre d'alésage

DIN 69881 VDI 3425 page 3

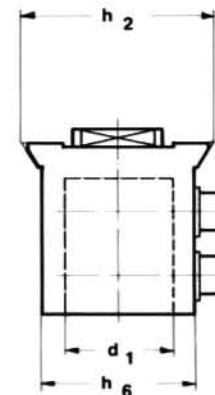
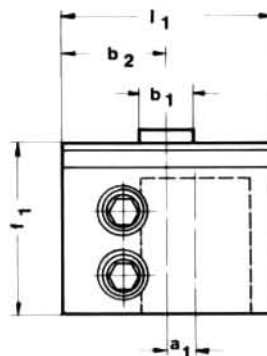

Nenngröße Size Taille	Nr.	Maße/Dimensions							
		d_1	a_1	b_1	b_2	h_2	h_6	f_1	l_1
16	10.500	32	8	16	34	56	39	54	68
20	10.510	40	10	20	39	72	53	65	78
25	10.520	50		25	59	90	71	80	98
32	10.530	60	12,5	25	49	115	95	94	98
40	10.540	80	12,5	25	59	140	115	120	118

Kühlmittelverteiler

Coolant distributor

Bloc d'arrosage

DIN 69881 VDI 3425 Bl. 3

DIN 69881 VDI 3425 Sheet 3

DIN 69881 VDI 3425 page 3

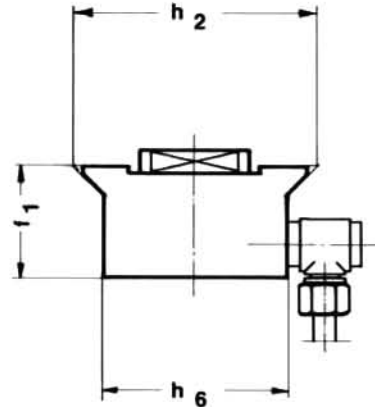
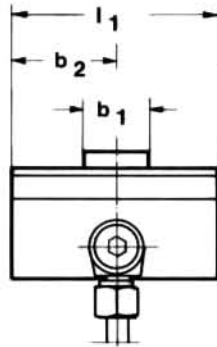

Nenngröße Size Taille	Nr.	Maße/Dimensions		h ₂	h ₆	f ₁	l ₁
		b ₁	b ₂				
16	10.550	16	34	56	39	28	68
20	10.560	20	39	72	53	34	78
25	10.570	25	39	90	71	42	78
32	10.580	25	49	115	95	54	98
40	10.590	25	59	140	115	60	118

2

Stellhülseaufnahme

Automotive Sleeves

Porte outil pour embout de réglage

DIN 69881 VDI 3425 Bl. 3

DIN 69881 VDI 3425 Sheet 3

DIN 69881 VDI 3425 page 3

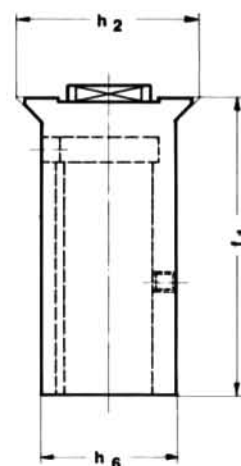
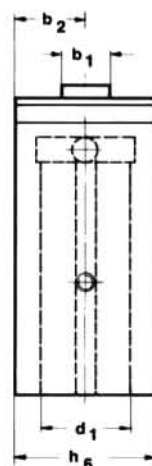

Nenngröße Size Taille	Nr.	Maße/Dimensions		b ₂	h ₂	h ₆	f ₁
		d ₁	b ₁				
16	10.600	36	16	26	56	52	120
20	10.610	36	20	26	72	52	120
25	10.620	48	25	35,5	90	71	140
32	10.630	48	25	47,5	115	95	140
40	10.640	48	25	57,5	140	115	140

Stellhülseaufnahme

Automotive Sleeves

Porte outil pour embout de réglage

DIN 69881 VDI 3425 Bl. 3

DIN 69881 VDI 3425 Sheet 3

DIN 69881 VDI 3425 page 3

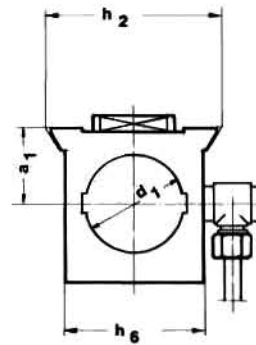
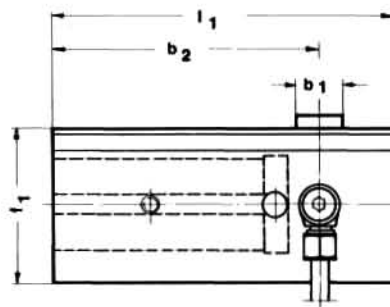

Nenngröße Size Taille	Nr.	Maße/Dimensions							
		d ₁	b ₁	b ₂	h ₂	h ₆	f ₁	l ₁	a ₁
16	10.650	36	16	90	56	52	58	119	30
20	10.660	36	20	100	72	52	58	139	30
25	10.670	48	25	135	90	71	80	174	40
32	10.680	48	25	175	115	95	80	224	40
40	10.690	48	25	175	140	115	80	224	40

Mehrfach-Werkzeughalter

schmal, lange Ausführung

Multi-Toolholder

narrow, long

Porte outil multiple

étroit, Execution longue

DIN 69881 VDI 3425 Bl. 3

DIN 69881 VDI 3425 Sheet 3

DIN 69881 VDI 3425 page 3

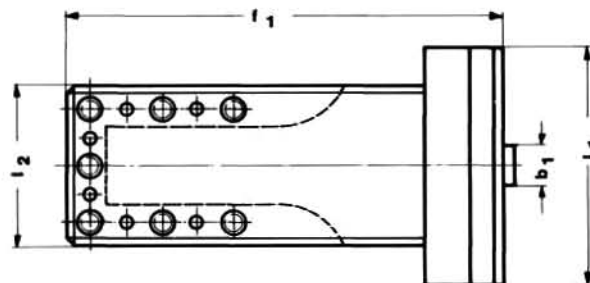
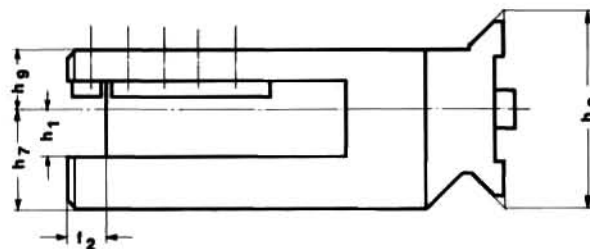
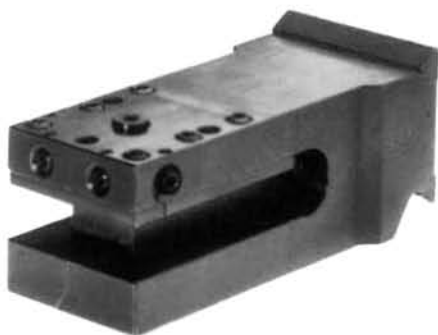

Nenngröße h ₁ Size Taille	Nr.	Maße/Dimensions							
		h ₂	h ₇	h ₉	b ₁	f ₁	f ₂	l ₁	l ₂
16	10.700	56	40	19	16	160	15	62	55
20	10.710	72	42,5	26	20	180	18	82	70
25	10.720	90	50	30	25	200	22	78	78
32	10.730	115	60	40	25	220	28	118	98
40	10.740	140	80	57	25	240	32	155	118

Doppel-Bohrstangenhalter Double-Boring Bar Holder Porte barre double

DIN 69881 VDI 3425 Bl. 3 DIN 69881 VDI 3425 Sheet 3 DIN 69881 VDI 3425 page 3

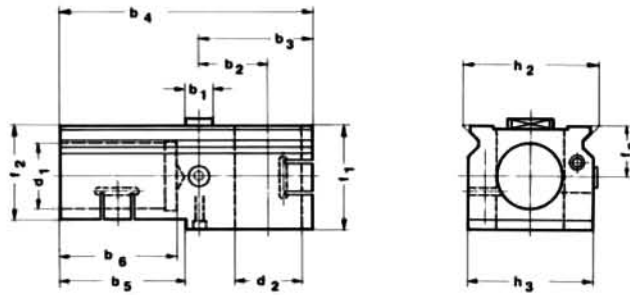

Nenngröße Size Taille	Nr.	Maße/Dimensions			h ₃	b ₁	b ₂	b ₃	b ₄	b ₅	b ₆	f ₁	f ₂	f ₃
		h ₂	d ₁	d ₂										
20	10.760	72	40	40	68	20	40	75	175		80	70	70	35
25	10.770	90	50	50	85	25	45	80	210	120	110	85	75	40
32	10.780	115	60	60	110	25	62,5	102	227	150	125	94	85	45
40	10.790	140	80	80	135	25	65	120	300	170	150	125	115	60

2

Werkzeughalterplatte Toolholder Plate Flasque porte outil

DIN 69881 VDI 3425 Bl. 3 DIN 69881 VDI 3425 Sheet 3 DIN 69881 VDI 3425 page 3



Lange Ausführung
Long execution
Exécution longue

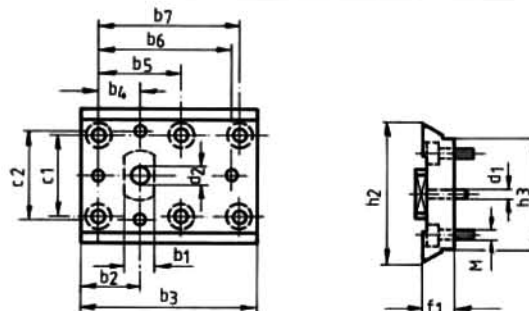

Nenngröße Size Taille	Nr.	Maße/Dimensions			b ₃	b ₄	b ₅	b ₆	b ₇	c ₁	c ₂	f ₁	M	d ₁	d ₂
		h ₂	h ₃	b ₁											
20	10.810	72	53	20	39	98	25		70	30	40	20	M8	6	13
25	10.820	90	71	25	39	115	25	50	87	87	55	55	M10	8	15
32	10.830	115	95	25	49	148	35	70	115	120	70	70	M10	8	15
40	10.840	140	115	25	59	200	45	90	172	172	90	90	M12	10	15

Kurze Ausführung
Short execution
Exécution court

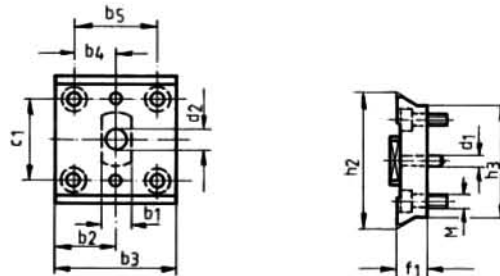

Nenngröße Size Taille	Nr.	Maße/Dimensions			b ₃	b ₄	b ₅	c ₁	f ₁	M	d ₁	d ₂	
		h ₂	h ₃	b ₁									b ₂
20	10.815	72	53	20	39	78	25	50	30	20	M8	6	13
25	10.825	90	71	25	39	78	25	50	55	25	M10	8	15
32	10.835	115	95	25	49	98	35	70	70	25	M10	8	15
40	10.845	140	115	25	59	160	45	132	90	35	M12	10	15

Bohrhalter für Wendeplattenbohrer

DIN 69881 VDI 3425 Bl. 3

Boring Holder for Carbide Tip Boring

DIN 69881 VDI 3425 Sheet 3

Porte outil pour forst à plaquette carbure

DIN 69881 VDI 3425 page 3

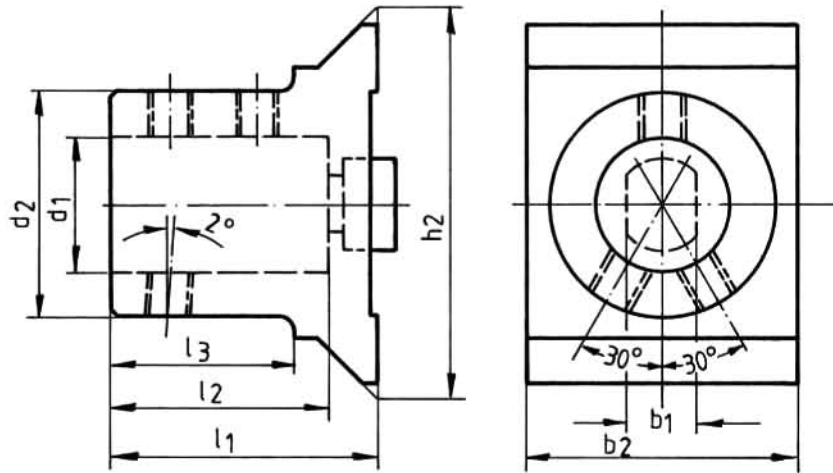

Nenngröße Size Taille	Nr.	Maße/Dimensions							
		h_2	b_1	b_2	d_1	d_2	l_1	l_2	l_3
16	10.900/20	56	16	68	20	44	66	54	44
16	10.900/25	56	16	68	25	49	71	59	49
16	10.900/32	56	16	68	32	56	75	63	54
16	10.900/40	56	16	68	40	64	85	73	60
20	10.910/20	72	20	78	20	44	66	54	44
20	10.910/25	72	20	78	25	49	71	59	49
20	10.910/32	72	20	78	32	56	75	63	54
20	10.910/40	72	20	78	40	64	85	73	60
20	10.910/50	72	20	78	50	74	95	83	70
25	10.920/20	90	25	98	20	44	66	54	44
25	10.920/25	90	25	98	25	49	71	59	49
25	10.920/32	90	25	98	32	56	75	63	54
25	10.920/40	90	25	98	40	64	85	73	60
25	10.920/50	90	25	98	50	74	95	83	70
32	10.930/20	115	25	98	20	44	66	54	44
32	10.930/25	115	25	98	25	49	71	59	49
32	10.930/32	115	25	98	32	56	75	63	54
32	10.930/40	115	25	98	40	64	85	73	60
32	10.930/50	115	25	98	50	74	95	83	70
40	10.940/20	140	25	118	20	44	66	54	44
40	10.940/25	140	25	118	25	49	71	59	49
40	10.940/32	140	25	118	32	56	75	63	54
40	10.940/40	140	25	118	40	64	85	73	60
40	10.940/50	140	25	118	50	74	95	83	70

**Bohrhalter für
Wendepplattenbohrer**

DIN 69881 VDI 3425 Bl. 3

**Boring Holder for Carbide
Tip Boring**

DIN 69881 VDI 3425 Sheet 3

**Porte outil pour forst à
plaquette carbure**

DIN 69881 VDI 3425 page 3

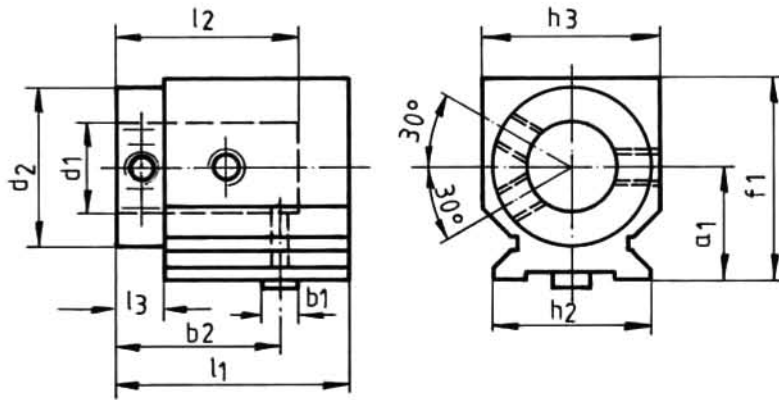

2

Nenngröße Size Taille	Nr.	Maße/Dimensions										
		a ₁	b ₁	b ₂	d ₁	d ₂	f ₁	h ₂	h ₃	l ₁	l ₂	l ₃
16	10.950/20	40	16	75	20	44	76	56	66	109	54	28
16	10.950/25	40	16	75	25	49	76	56	66	109	59	28
16	10.950/32	40	16	75	32	56	76	56	66	109	63	28
16	10.950/40	40	16	75	40	64	76	56	66	109	73	32
20	10.960/20	45	20	80	20	44	78	72	68	119	54	28
20	10.960/25	45	20	80	25	49	78	72	68	119	59	28
20	10.960/32	45	20	80	32	56	78	72	68	119	63	28
20	10.960/40	45	20	80	40	64	78	72	68	119	73	32
20	10.960/50	45	20	80	50	74	78	72	68	119	83	34
25	10.970/20	50	25	100	20	44	86	90	80	139	54	28
25	10.970/25	50	25	100	25	49	86	90	80	139	59	28
25	10.970/32	50	25	100	32	56	86	90	80	139	63	28
25	10.970/40	50	25	100	40	64	86	90	80	139	73	32
25	10.970/50	50	25	100	50	74	86	90	80	139	83	34
32	10.980/20	55	25	100	20	44	95	115	94	149	54	28
32	10.980/25	55	25	100	25	49	95	115	94	149	59	28
32	10.980/32	55	25	100	32	56	95	115	94	149	63	28
32	10.980/40	55	25	100	40	64	95	115	94	149	73	32
32	10.980/50	55	25	100	50	74	95	115	94	149	83	34
40	10.990/20	60	25	120	20	44	100	140	114	189	54	28
40	10.990/25	60	25	120	25	49	100	140	114	189	59	28
40	10.990/32	60	25	120	32	56	100	140	114	189	63	28
40	10.990/40	60	25	120	40	64	100	140	114	189	73	32
40	10.990/50	60	25	120	50	74	100	140	114	189	83	34

WH-Werkzeughalter für Bohrstangen

DIN 69881 VDI 3425 Bl. 3
Durchmesser und Drehmitte einstellbar

WH-Toolholder for Boring Bars

DIN 69881 VDI 3425 Sheet 3
Diameter and Centre turning point adjustable

Porte outil WH pour alésage

DIN 69881 VDI 3425 page 3
Diamètre et centrage réglables

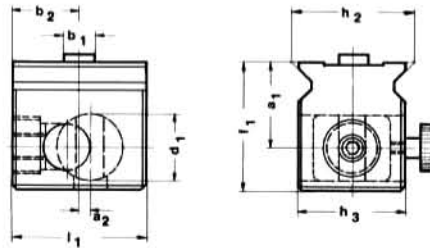

Nenngröße Size Taille	Nr.	Maße/Dimensions								
		d ₁	a ₁	a ₂	b ₁	b ₂	f ₁	h ₂	h ₃	l ₁
16	30.100	36	41	4	16	34	64	56	52	68
20	30.110	46	48	6	20	38	76	72	66	78
25	30.120	46	50	6	25	38	78	90	66	78
32	30.130	46	52	6	25	38	80	115	66	78
40	30.140	46	56	6	25	38	84	140	66	78

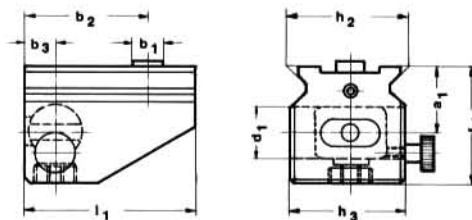

Nenngröße Size Taille	Nr.	Maße/Dimensions								
		d ₁	a ₁	b ₁	b ₂	b ₃	f ₁	h ₂	h ₃	l ₁
16	30.150	36	39	16	59	23	77	56	52	93
20	30.160	46	48	20	75	28	93	72	66	114
25	30.170	46	50	25	89	28	95	90	66	138
32	30.180	46	52	25	99	28	97	115	66	148
40	30.190	46	55	25	119	28	100	140	66	188

WH-Wechselhalter

WH-Infed Toolholders

WH-Supports interchangeable

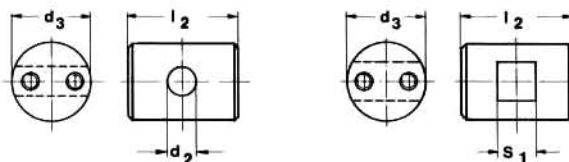

Nr.	Maße/Dimensions			Nr.	Maße/Dimensions			Nr.	Maße/Dimensions		
	d ₁	d ₂	l ₂		d ₁	d ₂	l ₂		d ₁	s ₁	l ₂
200.208	36	8	38	200.312	46	12	52	210.210	36	10	38
200.210	36	10	38	200.313	46	13	52	210.212	36	12	38
200.212	36	12	38	200.314	46	14	52	210.216	36	16	38
200.213	36	13	38	200.315	46	15	52	210.312	46	12	52
200.214	36	14	38	200.316	46	16	52	210.316	46	16	52
200.215	36	15	38	200.320	46	20	52	210.320	46	20	52
200.216	36	16	38	200.325	46	25	52				

Wechselhalter mit weiteren d₂ und s₁ Maßen auf Anfrage

Infed Toolholders with further d₂ and s₁ measurements on request

Support interchangeable avec autre dimension pour d₂ ou s₁ sur demande

Aufnahmehülsen

Adaptor Sleeve

Douille de réduction



Nr.	Maße/Dimensions			Nr.	Maße/Dimensions		
	d ₃	d ₂	l ₁		d ₃	d ₂	l ₁
100.110.32.060.	32	10	60	100.125.50.100	50	25	100
100.112.32.060	32	12	60	100.132.50.100	50	32	100
100.115.32.060	32	15	60	100.115.60.115	60	15	115
100.116.32.060	32	16	60	100.116.60.115	60	16	115
100.120.32.060	32	20	60	100.120.60.115	60	20	115
100.110.40.080	40	10	80	100.125.60.115	60	25	115
100.112.40.080	40	12	80	100.132.60.115	60	32	115
100.115.40.080	40	15	80	100.140.60.115	60	40	115
100.116.40.080	40	16	80	100.132.80.130	80	32	130
100.120.40.080	40	20	80	100.140.80.130	80	40	130
100.125.40.080	40	25	80	100.150.80.130	80	50	130
100.110.50.100	50	10	100	100.160.80.130	80	60	130
100.112.50.100	50	12	100	100.140.100.170	100	40	170
100.115.50.100	50	15	100	100.150.100.170	100	50	170
100.116.50.100	50	16	100	100.160.100.170	100	60	170
100.120.50.100	50	20	100	100.180.100.170	100	80	170

Aufnahmehülsen mit weiteren Maßen auf Anfrage

Adaptorsleeve with further measurements on request

Douille de réduction avec autres dimensions sur demande

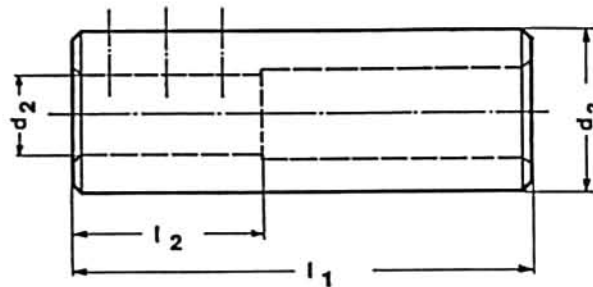

Nr.	Maße/Dimensions				Nr.	Maße/Dimensions			
	d ₃	d ₂	l ₁	l ₂		d ₃	d ₂	l ₁	l ₂
150.110.32.110	32	10	110	40	150.116.50.140	50	16	140	50
150.112.32.110	32	12	110	40	150.120.50.140	50	20	140	60
150.115.32.110	32	15	110	50	150.125.50.140	50	25	140	70
150.116.32.110	32	16	110	50	150.132.50.140	50	32	140	80
150.120.32.110	32	20	110	60	150.115.60.150	60	15	150	50
150.110.40.130	40	10	130	40	150.116.60.150	60	16	150	50
150.112.40.130	40	12	130	40	150.120.60.150	60	20	150	60
150.115.40.130	40	15	130	50	150.125.60.150	60	25	150	70
150.116.40.130	40	16	130	50	150.132.60.150	60	32	150	80
150.120.40.130	40	20	130	60	150.140.60.150	60	40	150	100
150.125.40.130	40	25	130	70	150.132.80.180	80	32	180	80
150.110.50.140	50	10	140	40	150.140.80.180	80	40	180	100
150.112.50.140	50	12	140	40	150.150.80.180	80	50	180	120
150.115.50.140	50	15	140	50	150.160.80.180	80	60	180	140

Aufnahmehülsen mit weiteren Maßen auf Anfrage

Adaptorsleeve with further measurements on request

Douille de réduction avec autres dimensions sur demande

Aufnahmehülsen

geschlitzt

Adaptor Sleeve

split

Douille de réduction

fendue

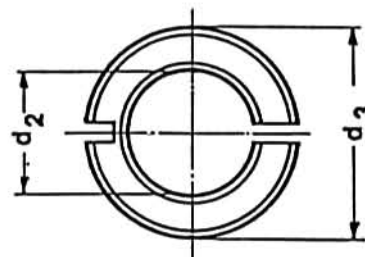
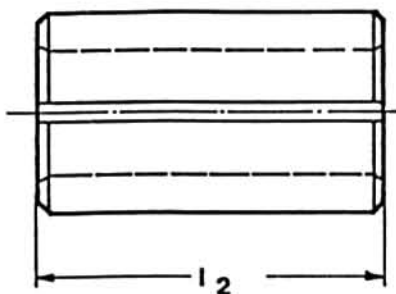

Nr.	Maße/Dimensions			Nr.	Maße/Dimensions		
	d ₃	d ₂	l ₂		d ₃	d ₂	l ₂
400.108.32.65	32	8	65	400.120.40.75	40	20	75
400.110.32.65	32	10	65	400.125.40.75	40	25	75
400.112.32.65	32	12	65	400.125,4.40.75	40	25,4	75
400.112,7.32.65	32	12,7	65	400.130.40.75	40	30	75
400.114.32.65	32	14	65	400.132.40.75	40	32	75
400.115.32.65	32	15	65	400.110.50.85	50	10	85
400.116.32.65	32	16	65	400.112.50.85	50	12	85
400.118.32.65	32	18	65	400.116.50.85	50	16	85
400.119,05.32.65	32	19,05	65	400.120.50.85	50	20	85
400.120.32.65	32	20	65	400.125.50.85	50	25	85
400.125.32.65	32	25	65	400.130.50.85	50	30	85
400.125,4.32.65	32	25,4	65	400.132.50.85	50	32	85
400.108.40.75	40	8	75	400.140.50.85	50	40	85
400.110.40.75	40	10	75	400.112.60.95	60	12	95
400.112.40.75	40	12	75	400.116.60.95	60	16	95
400.112,7.40.75	40	12,7	75	400.120.60.95	60	20	95
400.114.40.75	40	14	75	400.125.60.95	60	25	95
400.115.40.75	40	15	75	400.130.60.95	60	30	95
400.116.40.75	40	16	75	400.132.60.95	60	32	95
400.118.40.75	40	18	75	400.140.60.95	60	40	95
400.119,05.40.75	40	19,05	75	400.150.60.95	60	50	95

Aufnahmehülsen mit weiteren Maßen auf Anfrage

Adaptorsleeve with further measurements on request

Douille de réduction avec autres dimensions sur demande

Bohrerhalter

Morsetaper Sleeve

Douille porte forêt

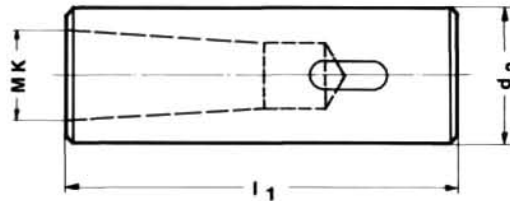

Nr.	Maße/Dimensions			Nr.	Maße/Dimensions		
	d ₃	MK	l ₁		d ₃	MK	l ₁
500.101.32.092	32	1	92	500.103.60.148	60	3	148
500.102.32.092	32	2	92	500.104.60.148	60	4	148
500.103.32.092	32	3	92	500.105.60.148	60	5	148
500.101.40.092	40	1	92	500.103.60.180	60	3	180
500.102.40.092	40	2	92	500.104.60.180	60	4	180
500.103.40.092	40	3	92	500.105.60.180	60	5	180
500.104.40.115	40	4	115	500.104.80.180	80	4	180
500.102.50.115	50	2	115	500.105.80.180	80	5	180
500.103.50.115	50	3	115	500.104.100.180	100	4	180
500.104.50.115	50	4	115	500.105.100.180	100	5	180

Bohrerhalter mit weiteren Maßen auf Anfrage

Morsetaper with further measurements on request

Douille porte foret avec autres dimensions sur demande

Spannzangenfutter

mit Zylinderschaft

Collet Chuck

with cylindrical shaft

Mandrin à pince

à queue cylindrique

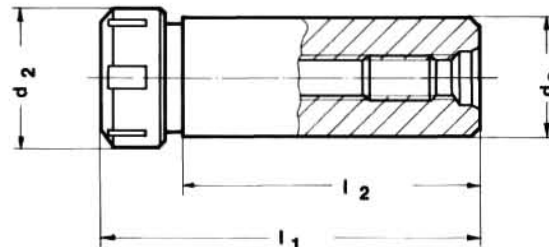

Nr.	Spannbereich		Maße/Dimensions		l ₁	l ₂	Spannzangen	Spannschlüssel
	Satz	Zange	d ₂	d ₃				
700.116/32	1-16	1	42	32	120	80	250 430 E	225
700.116/40	1-16	1	42	40	120	88	250 430 E	225
700.120/32	2-20	1	50	32	142	90	320 470 E	232
700.120/40	2-20	1	50	40	142	90	320 470 E	232
700.126/40	3-26	1	63	40	160	100	400 472 E	240
700.126/50	3-26	1	63	50	160	100	400 472 E	240

2

Stellhülsen

kurze Bauart

DIN 6327

Automotive to Morsetaper

Short

DIN 6327

Embout de réglage

Court

DIN 6327

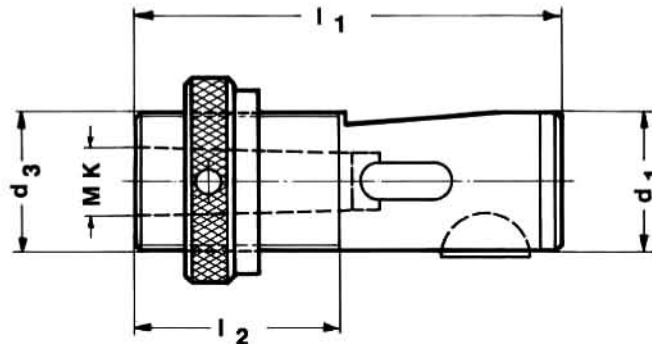

Nr.	Maße/Dimensions				
	MK	d ₁	d ₃	l ₁	l ₂
0120	1	28	Tr 28x2	95	42
0121	2	28	Tr 28x2	95	42
0126	2	36	Tr 36x2	118	50
0127	3	36	Tr 36x2	118	50
0134	3	48	Tr 48x2	144	65
0135	4	48	Tr 48x2	144	65

Reduzierhülsen

DIN 2185

Reducer Sleeve

DIN 2185

Douille de réduction

DIN 2185

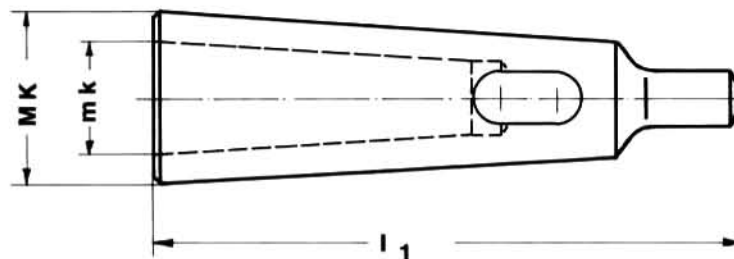

Nr.	Maße/Dimensions			Nr.	Maße		
	MK	mk	l ₁		MK	mk	l ₁
3002	2	1	92	3005	4	1	124
3003	3	1	99	3006	4	2	124
3004	3	2	112	3007	4	3	140





Angetriebene werkzeuge

Driven tools

Porte-outils motorisés

Angetriebene Werkzeugaufnahmen für die Komplettbearbeitung
Driven Tools for all Machining Operations
Porte-outil entraînés pour toutes opération en commande numérique

			Form	Page
Angetriebene Werkzeuge, Schaft 30 Sauter / Baruffaldi / Duplomatic	Driven tools, shank Ø 30 Sauter / Baruffaldi / Duplomatic	Porte-outils entraînés 30 Sauter / Baruffaldi / Duplomatic		3.30.1 - 3.30.7
Angetriebene Werkzeuge, Schaft 40 Sauter / Baruffaldi / Duplomatic	Driven tools, shank Ø 40 Sauter / Baruffaldi / Duplomatic	Porte-outils entraînés 40 Sauter / Baruffaldi / Duplomatic		3.40.1 - 3.40.7



**Angetriebene werkzeuge für Sauter-, Diplomatic-,
Baruffaldi-Revolver VDI30**

*Driven tools for Sauter-, Diplomatic-,
Baruffaldi-turret VDI30
Porte-outils motorisés pour tourelle Sauter,
Diplomatic et Baruffaldi VDI30*

Axial Bohr- und Fräskopf

Axial drilling and milling head

Tête de perçage et fraisage axial

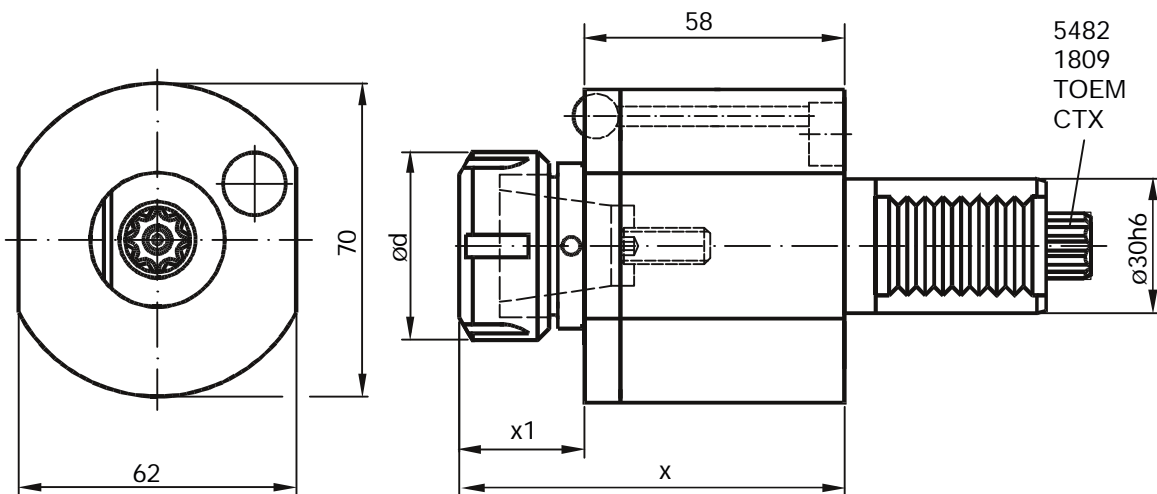

Innere Kühlmittelzufuhr. Zusatz IK an Bestellnummer anfügen.
Central cooling supply. Please add IK behind order no.

Sauter-Revolver DIN 5482 15x12 = 5482
Sauter-Revolver DIN 5480 = CTX
Diplomatic DIN 1809 = 1809
Baruffaldi TOEM 160 = TOEM
Beispiel / Example: 40.3025 5482

Bestell Nr. Order No.	i	x	x1	d	n_{max} [1/min]	T_{max} [Nm]	Schlüsselsatz Wrench-set	Spannzange (siehe 1.27) Collet (see 1.27)
40.3020 ...	1:1	85	27	35	6000	25	GS30/HS40	RD/ER 25 428E (1-13)
40.3025 ...	1:1	86	28	42	6000	25	225/HS40	RD/ER 25 430E (1-16)

Axial Bohr- und Fräskopf

Axial drilling and milling head

Tête de perçage et fraisage axial

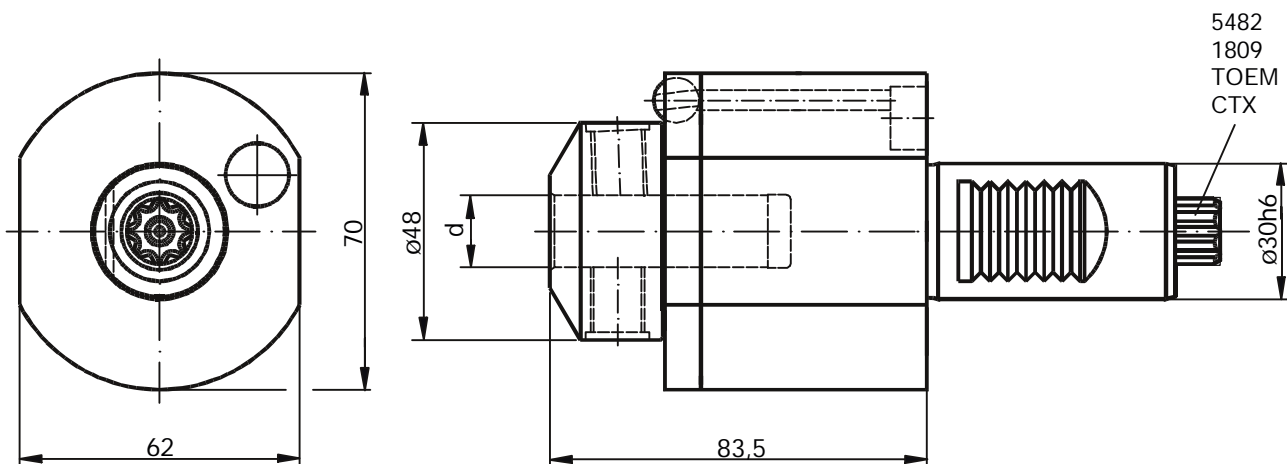

Bestell Nr. Order No.	i	d	n_{max} [1/min]	T_{max} [Nm]
40.3012 WN ...	1:1	12	6000	25
40.3016 WN ...	1:1	16	6000	25

Sauter-Revolver DIN 5482 15x12 = 5482
Sauter-Revolver DIN 5480 = CTX
Diplomatic DIN 1809 = 1809
Baruffaldi TOEM 160 = TOEM
Beispiel / Example: 40.3016 WN 5482

Axial Bohr-
und Fräskopf

Axial drilling and
milling head

Tête de perçage
et fraisage axial

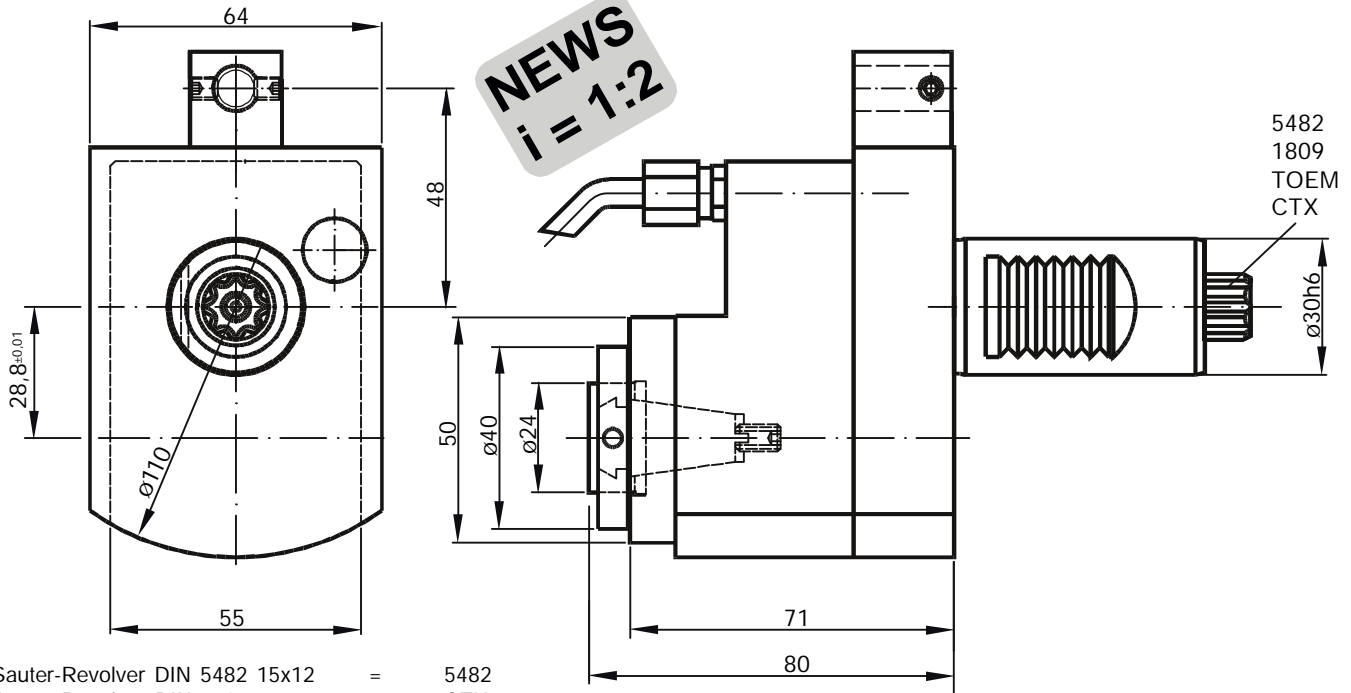

Sauter-Revolver DIN 5482 15x12 = 5482
 Sauter-Revolver DIN 5480 = CTX
 Diplomatic DIN 1809 = 1809
 Baruffaldi TOEM 160 = TOEM
 Beispiel / Example: 50.3016 1890/1

Bestell Nr. Order No.	i	n_{max} [1/min]	T_{max} [Nm]	Schlüsselsatz Wrench-set	Spannzange (siehe 1.27) Collet (see 1.27)
50.3016 ... /1	1:2	12000	8	LS16/HS40	RD/ER 16 426E (1-10)

Innere Kühlmittelzufuhr.
Zusatz IK an Bestellnummer anfügen.
Central cooling supply.
Please add IK behind order no.

Axial
Gewindebohrkopf

Axial
tapping head

Tête de
taraudage axial

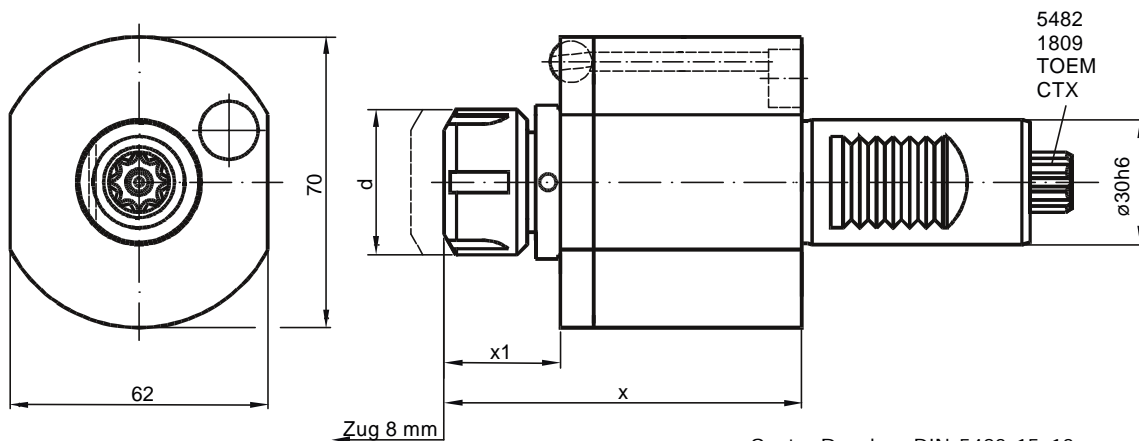

Sauter-Revolver DIN 5482 15x12 = 5482
 Sauter-Revolver DIN 5480 = CTX
 Diplomatic DIN 1809 = 1809
 Baruffaldi TOEM 160 = TOEM
 Beispiel / Example: 41.3025 CTX

Bestell Nr. Order No.	i	x	x1	d	n_{max} [1/min]	T_{max} [Nm]	Schlüsselsatz Wrench-set	Spannzange (siehe 1.27) Collet (see 1.27)
41.3020 ...	1:1	85	27	35	6000	16	GS30/GS22	RD/ER 20 428E (2-13)
41.3025 ...	1:1	86	29	42	6000	16	225/GS22	RD/ER 25 430E (2-16)

Axial
Fräskopf

Axial
milling head

Tête
fraisage axial

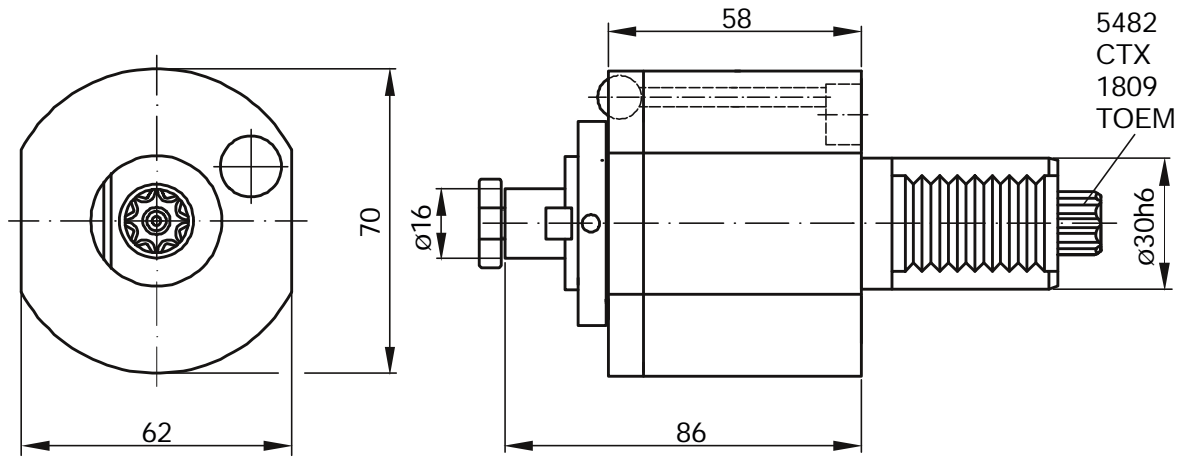

Bestell Nr. Order No.	i	n_{max} [1/min]	T_{max} [Nm]
42.3016 ...	1:1	6000	25

Andere \varnothing verfügbar
Other \varnothing available
Autres \varnothing possible

Sauter-Revolver DIN 5482 15x12 = 5482
Sauter-Revolver DIN 5480 = CTX
Diplomatic DIN 1809 = 1809
Baruffaldi TOEM 160 = TOEM
Beispiel / Example: 42.3016 TOEM

3

Radial Bohr-
und Fräskopf

Radial drilling
and milling head

Tête de perçage
et de fraisage radial

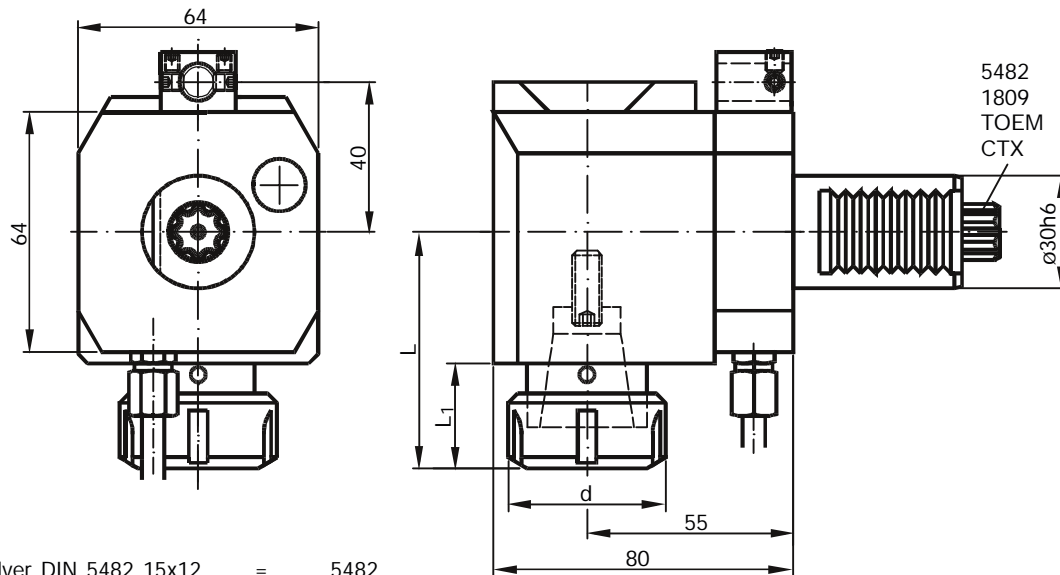

Sauter-Revolver DIN 5482 15x12 = 5482
Sauter-Revolver DIN 5480 = CTX
Diplomatic DIN 1809 = 1809
Baruffaldi TOEM 160 = TOEM
Beispiel / Example: 60.3025 5482

Innere Kühlmittelzufuhr. Zusatz IK an Bestellnummer anfügen.
Central cooling supply. Please add IK behind order no.

Bestell Nr. Order No.	i	d	L	L1	n_{max} [1/min]	T_{max} [Nm]	Schlüsselsatz Wrench-set	Spannzange (siehe 1.27) Collet (see 1.27)
60.3020 ...	1:1	35	63	27	6000	25	GS30/HS40	RD/ER 20 428E (2-13)
60.3020 ... / 1	1:2	35	63	27	12000	12	GS30/HS40	RD/ER 20 428E (2-13)
60.3020 ... / 2	2:1	35	63	27	4000	40	GS30/HS40	RD/ER 20 428E (2-13)
60.3025 ...	1:1	42	64	28	6000	25	225/HS40	RD/ER 25 430E (2-16)
60.3025 ... / 2	2:1	42	64	28	4000	40	225/HS40	RD/ER 25 430E (2-16)

Radial Bohr- und Fräskopf

Radial drilling and milling head

Tête de perçage et fraisage radial

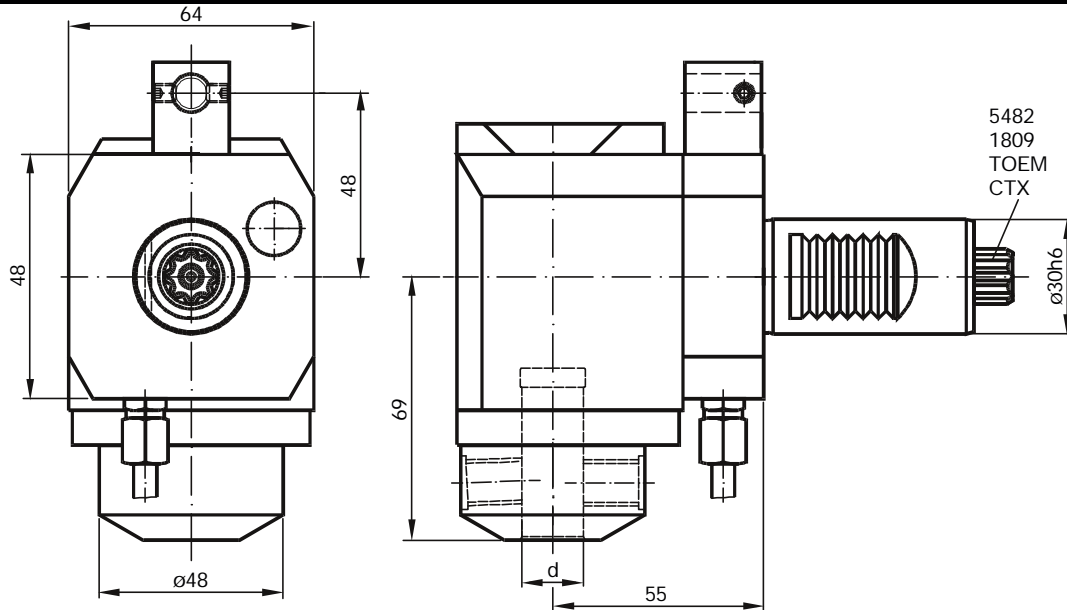

Bestell Nr. Order No.	i	d	n _{max} [1/min]	T _{max} [Nm]
60.3012 WN ...	1:1	12	6000	25
60.3016 WN ...	1:1	16	6000	25
60.3016 WN ... / 2	2:1	16	4000	40
60.3020 WN ... / 2	2:1	20	4000	40

Sauter-Revolver DIN 5482 15x12 = 5482
 Sauter-Revolver DIN 5480 = CTX
 Diplomatic DIN 1809 = 1809
 Baruffaldi TOEM 160 = TOEM
 Beispiel / Example: 60.3016 WN CTX

Innere Kühlmittelzufuhr. Zusatz IK an Bestellnummer anfügen.
 Central cooling supply. Please add IK behind order no.

Radial Gewindebohrkopf

Radial tapping head

Tête de taraudage radial

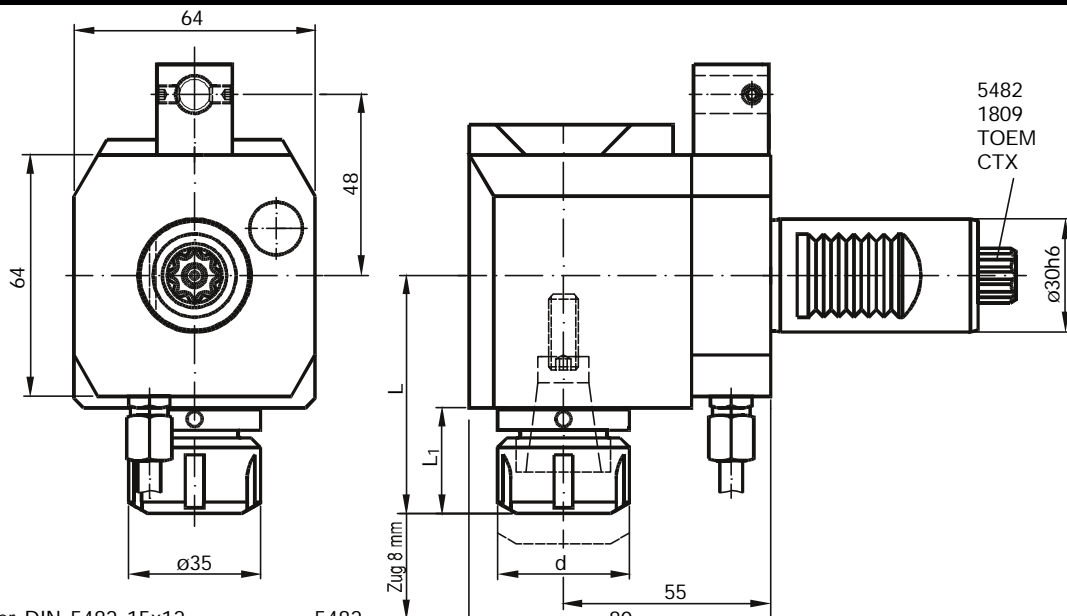

Sauter-Revolver DIN 5482 15x12 = 5482
 Sauter-Revolver DIN 5480 = CTX
 Diplomatic DIN 1809 = 1809
 Baruffaldi TOEM 160 = TOEM
 Beispiel / Example: 61.3020 TOEM

Bestell Nr. Order No.	i	d	L	L1	n _{max} [1/min]	T _{max} [Nm]	Schlüsselsatz Wrench-set	Spannzange (siehe 1.27) Collet (see 1.27)
61.3020 ...	1:1	35	76	27	6000	16	GS30/GS22	RD/ER 20 428E (2-13)
61.3025 ...	1:1	42	77	28	6000	16	225/GS22	RD/ER 25 430E (2-16)

Radial Fräskopf

Radial milling head

Tête de fraisage radial

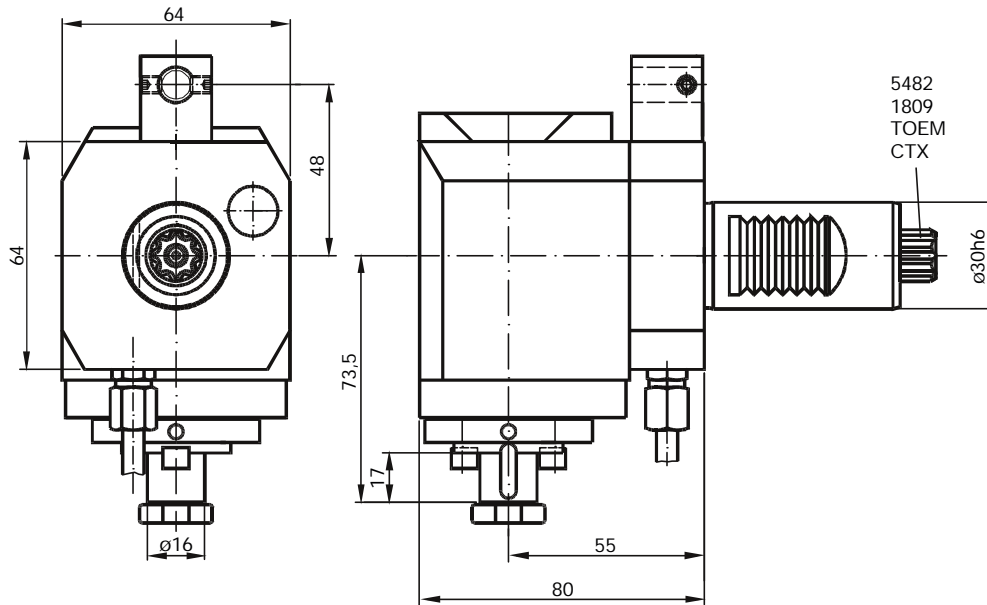

Bestell Nr. Order No.	i	n_{max} [1/min]	T_{max} [Nm]
62.3016 ...	1:1	6000	25
62.3016 ... / 2	2:1	4000	40

Andere ø auf Anfrage.
Other ø on request.
Autres ø sur demande.

Sauter-Revolver DIN 5482 15x12	=	5482
Sauter-Revolver DIN 5480	=	CTX
Diplomatic DIN 1809	=	1809
Baruffaldi TOEM 160	=	TOEM
Beispiel / Example: 62.3016 CTX		

3

Radial Bohr- und Fräskopf, zurückgesetzt

Radial drilling and milling head

Tête de perçage et fraisage radial

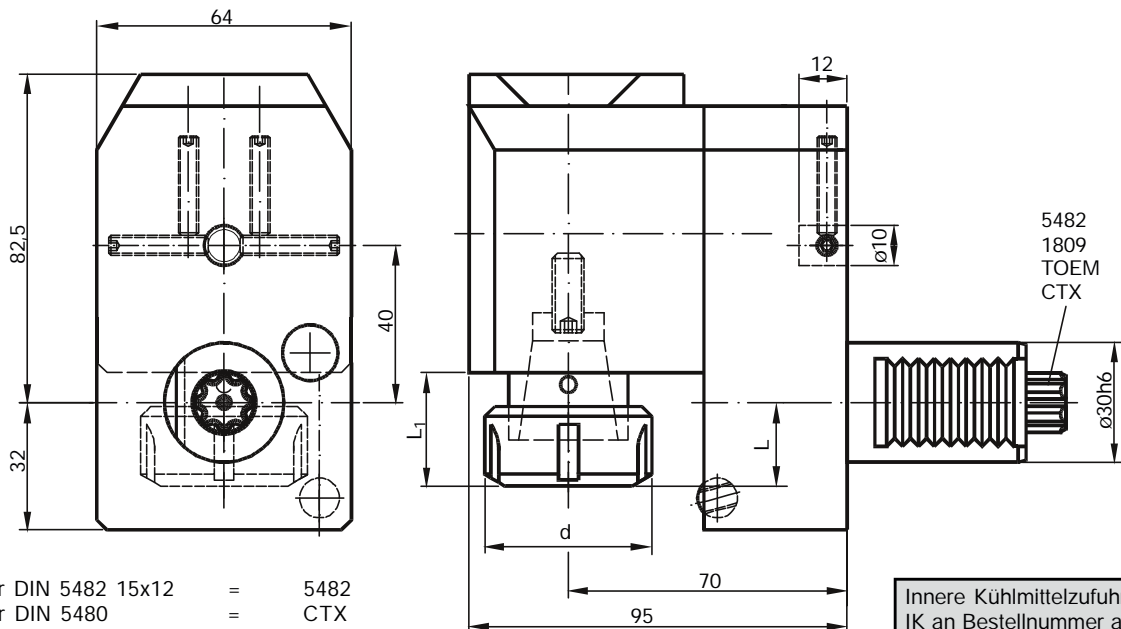

Sauter-Revolver DIN 5482 15x12	=	5482
Sauter-Revolver DIN 5480	=	CTX
Diplomatic DIN 1809	=	1809
Baruffaldi TOEM 160	=	TOEM
Beispiel / Example: 80.3020 5482/2		

Innere Kühlmittelzufuhr. Zusatz IK an Bestellnummer anfügen.
Central cooling supply. Please add IK behind order no.

Bestell Nr. Order No.	i	d	L	L1	n_{max} [1/min]	T_{max} [Nm]	Schlüsselsatz Wrench-set	Spannzange (siehe 1.27) Collet (see 1.27)
80.3020 ...	1:1	35	20	27	6000	25	GS30/HS40	RD/ER 20 428E (2-13)
80.3020 ... / 1	1:2	35	20	27	12000	12	GS30/HS40	RD/ER 20 428E (2-13)
80.3020 ... / 2	2:1	35	20	27	4000	40	GS30/HS40	RD/ER 20 428E (2-13)
80.3025 ...	1:1	42	21	28	6000	25	225/HS40	RD/ER 25 430E (2-16)
80.3025 ... / 2	2:1	42	21	28	4000	40	225/HS40	RD/ER 25 430E (2-16)

Radial
Gewindebohrkopf
achsversetzt

Radial
tapping head
offset

Tête de taraudage
radial

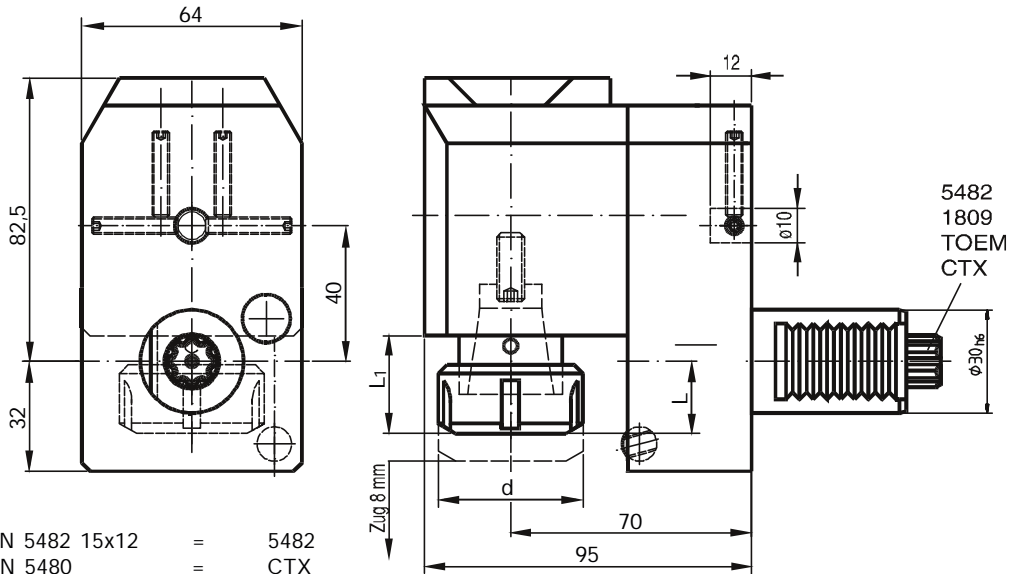

Sauter-Revolver DIN 5482 15x12 = 5482
 Sauter-Revolver DIN 5480 = CTX
 Diplomatic DIN 1809 = 1809
 Baruffaldi TOEM 160 = TOEM
 Beispiel / Example: 81.3025 CTX

Bestell Nr. Order No.	i	d	L	L1	n_{max} [1/min]	T_{max} [Nm]	Schlüsselsatz Wrench-set	Spannzange (siehe 1.27) Collet (see 1.27)
81.3020 ...	1:1	35	25	32	6000	16	GS30/GS22	RD/ER 20 428E (2-13)
81.3025 ...	1:1	42	26	33	6000	16	225/GS22	RD/ER 25 430E (2-16)

Radial Bohr- und
Fräskopf, achsversetzt

Radial drilling and
milling head, offset

Tête de perçage
et fraisage radial

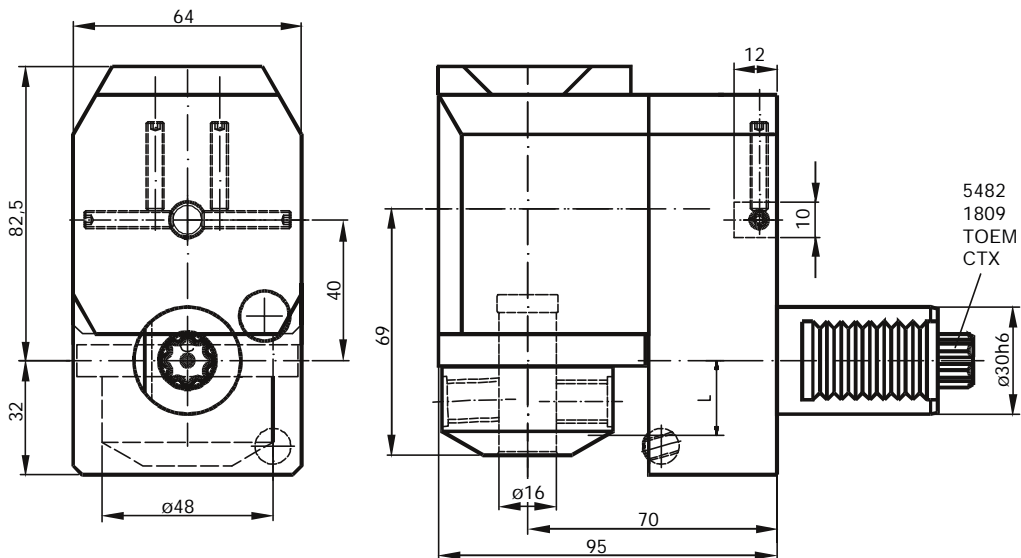

Sauter-Revolver DIN 5482 15x12 = 5482
 Sauter-Revolver DIN 5480 = CTX
 Diplomatic DIN 1809 = 1809
 Baruffaldi TOEM 160 = TOEM
 Beispiel / Example: 80.3016 WN CTX

Andere \varnothing auf Anfrage.
 Other \varnothing on request.
 Autres \varnothing sur demande.

Bestell Nr. Order No.	i	n_{max} [1/min]	T_{max} [Nm]
80.3016 WN ...	1:1	6000	25
80.3016 WN ... / 2	2:1	4000	40

Innere Kühlmittelzufuhr. Zusatz IK an Bestellnummer anfügen.
 Central cooling supply. Please add IK behind order no.

Schwenkkopf
± 105°

Swivel head
± 105°

Tête pivotante
± 105°

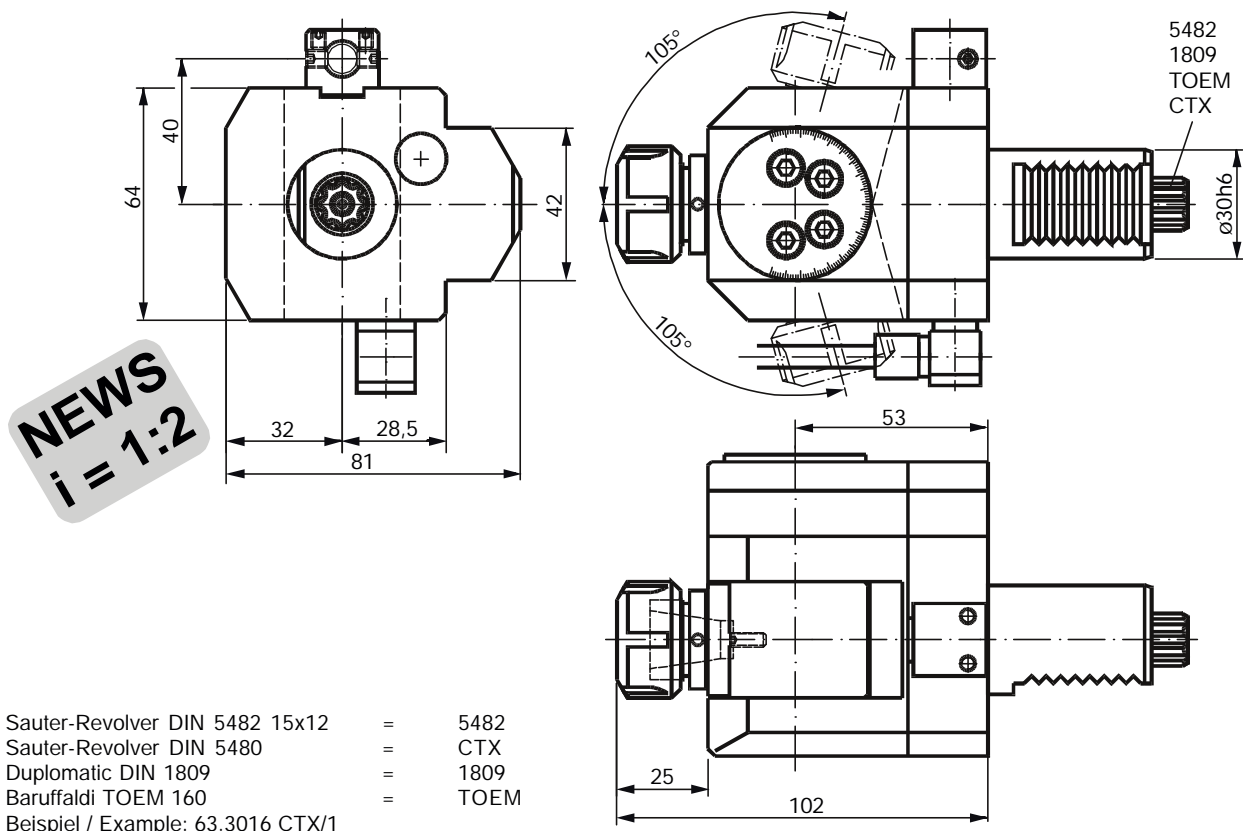

Bestell Nr. Order No.	i	n _{max} [1/min]	T _{max} [Nm]	Schlüsselsatz Wrench-set	Spannzange (siehe 1.27) Collet (see 1.27)
63.3016 ... /1	1:2	10000	10	GS35/HS28	RD/ER 16 426E (1-10)
63.3020 ...	1:1	5000	16	GS25/220	RD/ER 20 428E (2-13)

Radial
Scheibenfräserkopf

Radial drilling head
for side milling cutters

Tête de fraisage radial
pour fraise scie

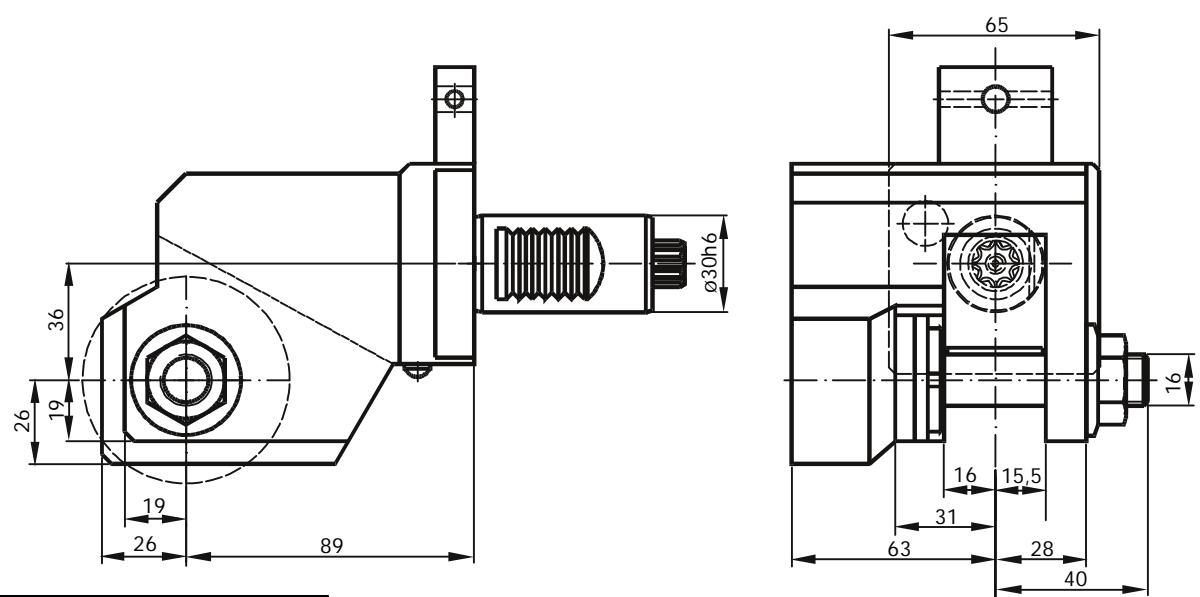

Bestell Nr. Order No.	i	n _{max} [1/min]	T _{max} [Nm]
64.3016 5482	3:2	2000	40



**Angetriebene werkzeuge für Sauter-, Diplomatic-,
Baruffaldi-Revolver VDI40**

*Driven tools for Sauter-, Diplomatic-,
Baruffaldi-turret VDI40
Porte-outils motorisés pour tourelle Sauter,
Diplomatic et Baruffaldi VDI40*

Axial Bohr- und Fräskopf

Axial drilling and milling head

Tête de perçage et fraisage axial

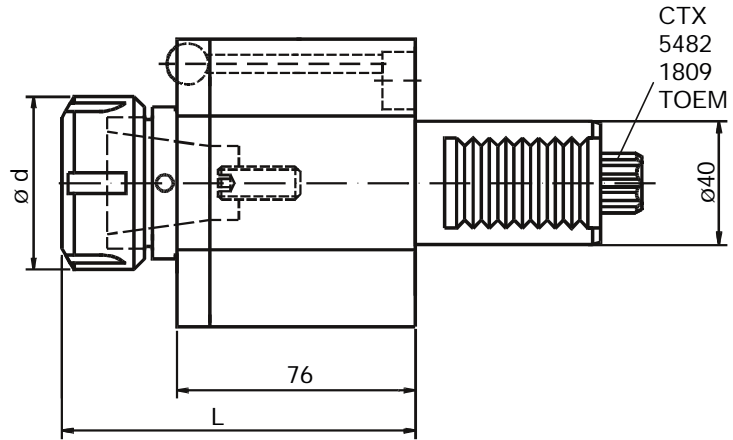
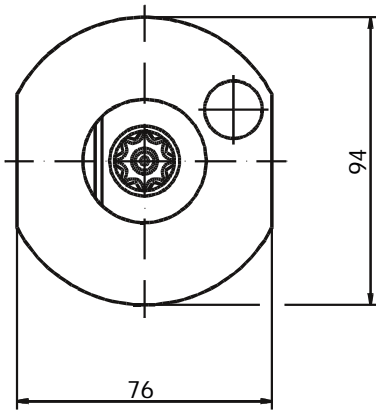

Innere Kühlmittelzufuhr; Zusatz IK an Bestellnummer anfügen
Central cooling supply; Please add IK behind order no.

Sauter-Revolver DIN 5480 = CTX
Sauter-Revolver DIN 5482 17 x 14 = 5482
Diplomatic DIN 1809 = 1809
Baruffaldi TOEM 200 = TOEM
Beispiel / Example: 40.4032 TOEM

Bestell Nr Order No.	d	i	L	n_{max} [1/min]	T_{max} [Nm]	Schlüsselsatz Wrench-set	Spannzange (siehe 1.27) Collet (see 1.27)
40.4025 ...	42	1:1	107	5000	50	225/DIN 1810B 45-50	RD/ER 25 430E (1-16)
40.4032 ...	50	1:1	109	5000	50	232/DIN 1810B 45-50	RD/ER 32 470E (3-20)

3

Axial Bohr- und Fräskopf

Axial drilling and milling head

Tête de perçage et fraisage axial

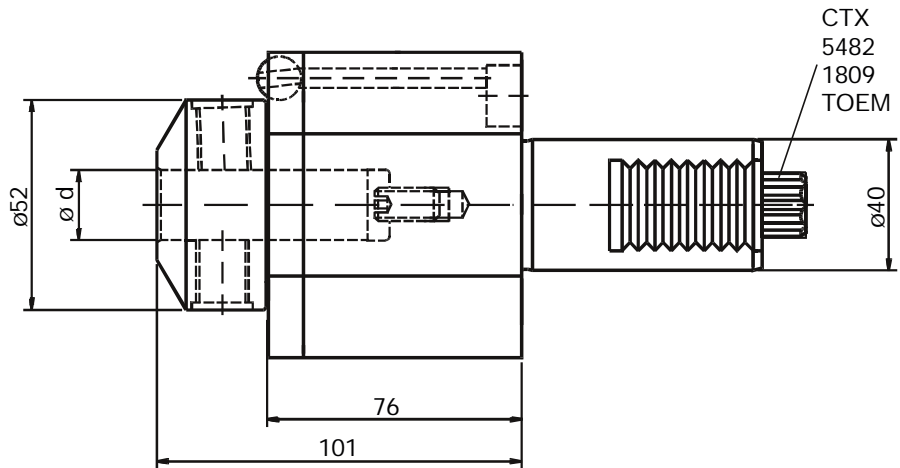
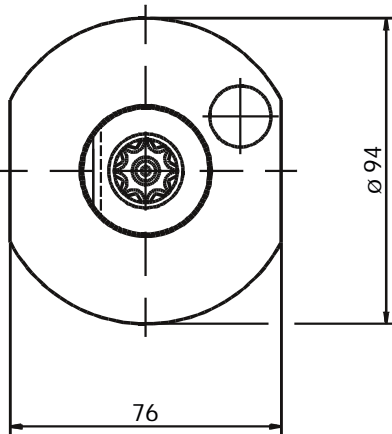

Bestell Nr Order No.	i	d	n_{max} [1/min]	T_{max} [Nm]
40.4010 WN ...	1:1	10	5000	50
40.4012 WN ...	1:1	12	5000	50
40.4016 WN ...	1:1	16	5000	50
40.4020 WN ...	1:1	20	5000	50
40.4025 WN ...	1:1	25	5000	50

Innere Kühlmittelzufuhr; Zusatz IK an Bestellnummer anfügen
Central cooling supply; Please add IK behind order no.

Sauter-Revolver DIN 5480 = CTX
Sauter-Revolver DIN 5482 17 x 14 = 5482
Diplomatic DIN 1809 = 1809
Baruffaldi TOEM 200 = TOEM
Beispiel / Example: 40.4016 WN 5482

Axial Bohr- und Fräskopf

Axial drilling and milling head

Tête de perçage et fraisage axial

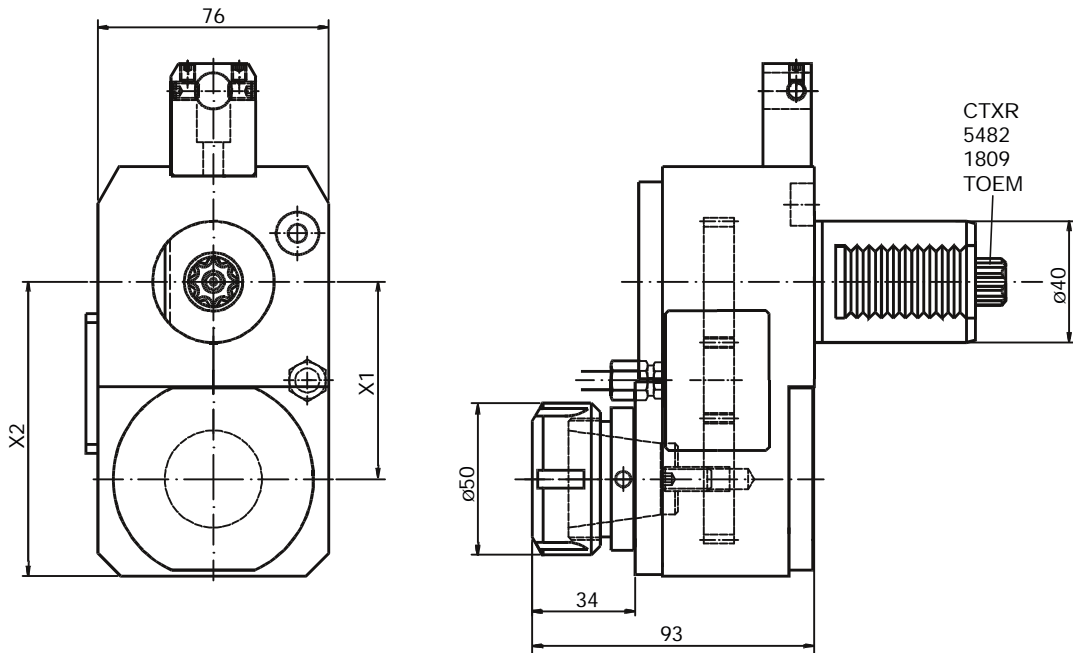

Innere Kühlmittelzufuhr; Zusatz IK an Bestellnummer anfügen
Central cooling supply; Please add IK behind order no.

Sauter-Revolver DIN 5480[^] = CTX R
Sauter-Revolver DIN 5482 17 x 14 = 5482
Duplomatic DIN 1809 = 1809
Baruffaldi TOEM 200 = TOEM
Beispiel / Example: 50.4025 5482

Bestell Nr Order No.	i	X ₁	X ₂	n _{max} [1/min]	T _{max} [Nm]	Schlüsselsatz Wrench-set	Spannzange (siehe 1.27) Collet (see 1.27)
50.4032 ...	1:1	65	97	5000	40	225/DIN 1810B 45-50	RD/ER 32 470E (3-20)
50.4032 ... / 2	2:1	50	92	5000	65	225/DIN 1810B 45-50	RD/ER 32 470E (3-20)
50.4025 ... / 1	1:2	auf Anfrage / on request sur demande				225/DIN 1810B 45-50	RD/ER 25 430E (1-16)

Axial Gewindebohrkopf

Axial tapping head

Tête de taraudage axial

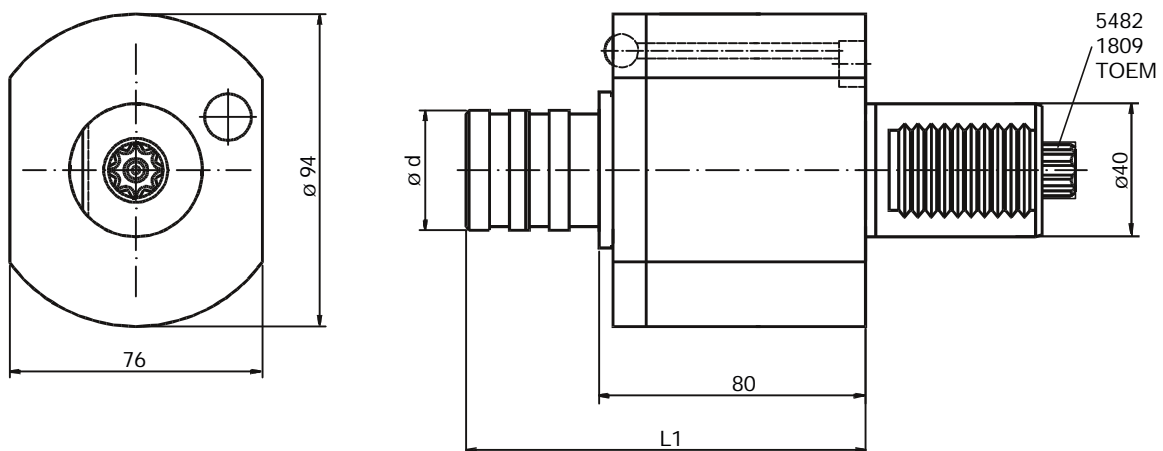

Bestell Nr Order No.	d	i	L ₁	n _{max} [1/min]	T _{max} [Nm]	Gewindebohraufnahme Tapping adaptor
41.4012 ...	36	1:1	120	5000	50	WFLK 1 (M3-M10)
41.4020 ...	53	1:1	143	5000	50	WFLK 2 (M8-M20)

Sauter-Revolver DIN 5482 17 x 14 = 5482
Duplomatic DIN 1809 = 1809
Baruffaldi TOEM 200 = TOEM
Beispiel / Example: 41.4012 5482

Axial Fräskopf

Axial milling head

Tête de fraisage axial

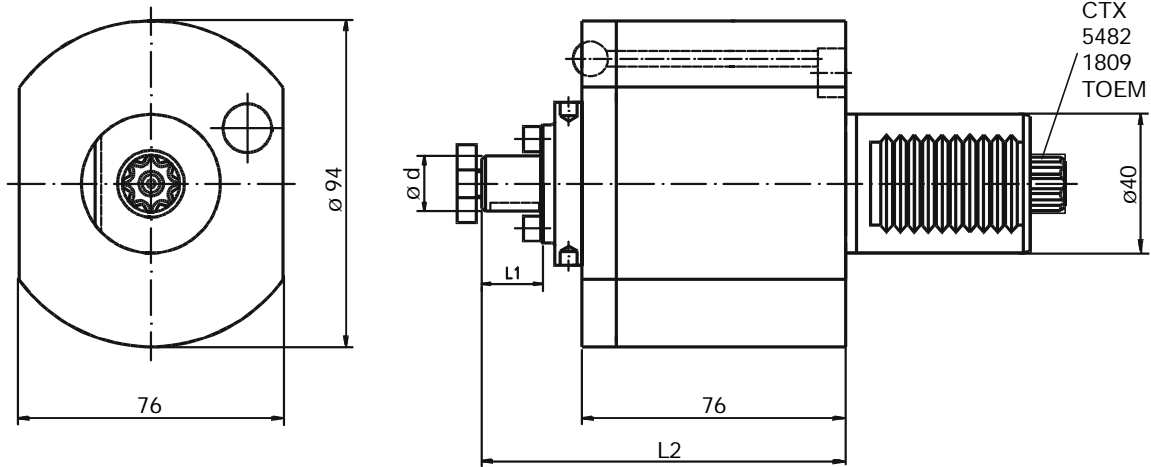

Bestell Nr Order No.	d ₁	i	L ₁	L ₂	n _{max} [1/min]	T _{max} [Nm]	Schlüsselsatz Wrench-set
42.4013 ...	13	1:1	17,5	105	5000	50	DIN 1810B 45-50
42.4016 ...	16	1:1	17,5	105	5000	50	DIN 1810B 45-50
42.4022 ...	22	1:1	19	106,5	5000	50	DIN 1810B 45-50
42.4027 ...	27	1:1	19	106,5	5000	50	DIN 1810B 45-50

Sauter-Revolver DIN 5480 = CTX
 Sauter-Revolver DIN 5482 17 x 14 = 5482
 Diplomatic DIN 1809 = 1809
 Baruffaldi TOEM 200 = TOEM
 Beispiel / Example: 42.4013 5482

3

Radial Bohr- und Fräskopf

Radial drilling and milling head

Tête de perçage et de fraisage radial

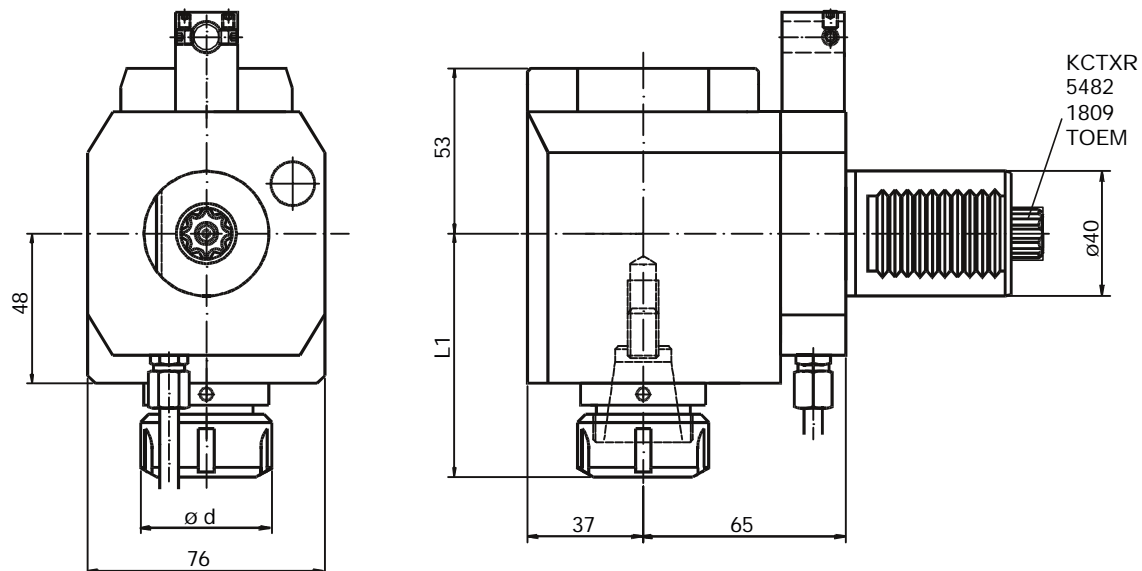

Innere Kühlmittelzufuhr; Zusatz IK an Bestellnummer anfügen
 Central cooling supply; Please add IK behind order no.

Sauter-Revolver DIN 5480 = KCTXR
 Sauter-Revolver DIN 5482 17 x 14 = 5482
 Diplomatic DIN 1809 = 1809
 Baruffaldi TOEM 200 = TOEM
 Beispiel / Example: 60.4025 KCTXR

Bestell Nr Order No.	d	i	L	n _{max} [1/min]	T _{max} [Nm]	Schlüsselsatz Wrench-set	Spannzange (siehe 1.27) Collet (see 1.27)
60.4025 ...	42	1:1	78	5000	50	DIN 1810B 45-50	RD/ER 25 430E (2-16)
60.4032 ...	50	1:1	82	5000	50	DIN 1810B 45-50	RD/ER 32 470E (3-20)
60.4025 ... / 1	42	1:2	78	9000	25	DIN 1810B 45-50	RD/ER 25 430E (2-16)
60.4032 ... / 2	50	2:1	82	5000	80	DIN 1810B 45-50	RD/ER 32 470E (3-20)

Radial Bohr- und Fräskopf

Radial drilling and milling head

Tête de perçage et fraisage radial

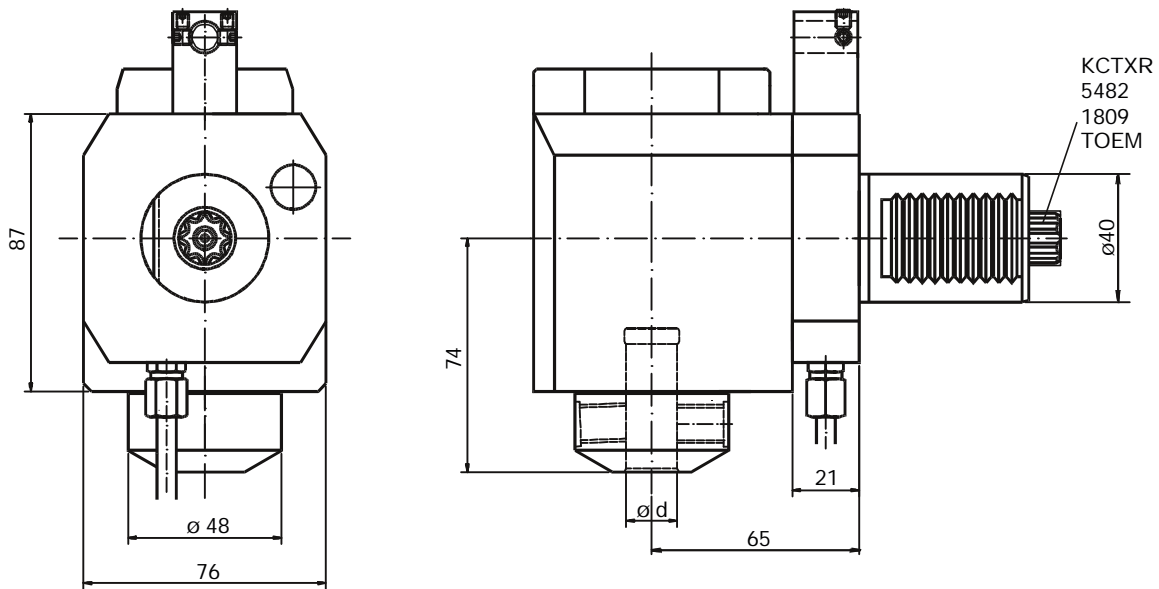

Bestell Nr Order No.	i	d	n_{max} [1/min]	T_{max} [Nm]
60.4008 WN ...	1:1	8	5000	50
60.4010 WN ...	1:1	10	5000	50
60.4012 WN ...	1:1	12	5000	50
60.4016 WN ...	1:1	16	5000	50
60.4020 WN ...	1:1	20	5000	50

Sauter-Revolver DIN 5480 = KCTXR
 Sauter-Revolver DIN 5482 17 x 14 = 5482
 Diplomatic DIN 1809 = 1809
 Baruffaldi TOEM 200 = TOEM
 Beispiel / Example: 60.4016 WN KCTXR

Innere Kühlmittelzufuhr; Zusatz IK an Bestellnummer anfügen
 Central cooling supply; Please add IK behind order no.

Radial Fräskopf

Radial milling head

Tête de fraisage radial

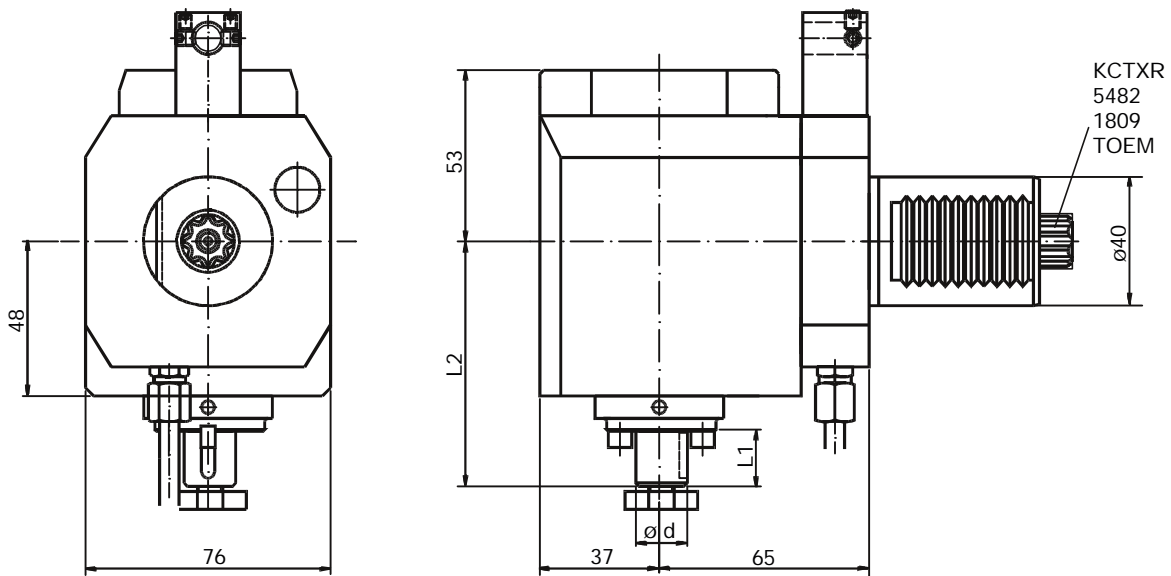

Bestell Nr Order No.	d	i	L_1	L_2	n_{max} [1/min]	T_{max} [Nm]
62.4016 ...	16	1:1	17,5	76	5000	50
62.4022 ...	22	1:1	19	77,5	5000	50
62.4027 ...	27	1:1	19	77,5	9000	25

Sauter-Revolver DIN 5480 = KCTXR
 Sauter-Revolver DIN 5482 17 x 14 = 5482
 Diplomatic DIN 1809 = 1809
 Baruffaldi TOEM 200 = TOEM
 Beispiel / Example: 62.4016 5482

Radial Bohr- und Fräskopf achsversetzt

Radial drilling and milling head offset

Tête de perçage et fraisage radial

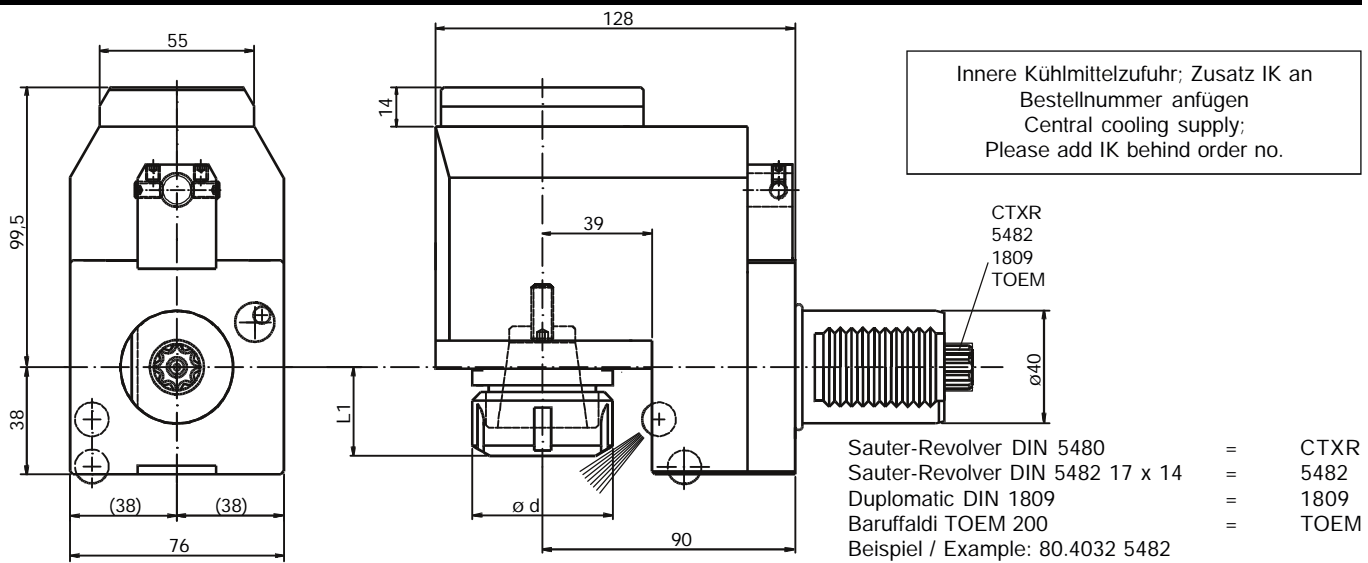

Bestell Nr Order No.	i	d	L_1	n_{max} [1/min]	T_{max} [Nm]	Schlüsselsatz Wrench-set	Spannzange (siehe 1.27) Collet (see 1.27)
80.4025 ...	1:1	42	29	5000	50	225/DIN 1810B 45-50	RD/ER 25 430E (2-16)
80.4032 ...	1:1	50	31,5	5000	50	232/DIN 1810B 45-50	RD/ER 32 470E (3-20)
80.4025 .../115	1:1,5	42	29	9000	30	225/DIN 1810B 45-50	RD/ER 25 430E (2-16)
80.4032 ... /151	1,5:1	50	31,5	5000	75	232/DIN 1810B 45-50	RD/ER 32 470E (3-20)
80.4032 ... /3	3:1	50		Maße auf Anfrage / Dimensions on request / Dimensions sur demande			RD/ER 32 470E (3-20)

3

Radial Bohr- und Fräskopf achsversetzt

Radial drilling and milling head offset

Tête de perçage et fraisage radial

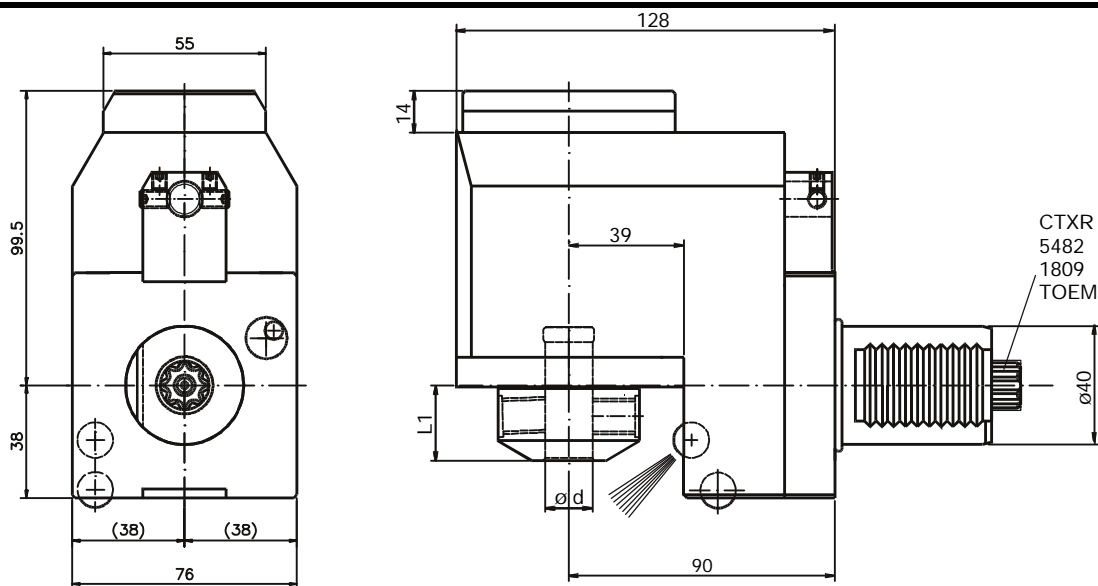

Bestell Nr Order No.	i	d	L_1	n_{max} [1/min]	T_{max} [Nm]
80.4016 WN ...	1:1	16	28	5000	50
80.4020 WN ...	1:1	20	28	5000	50
80.4020 WN .../3	3:1	20		Maße auf Anfrage Dimensions on request Dimensions sur demande	

Innere Kühlmittelzufuhr; Zusatz IK an Bestellnummer anfügen
Central cooling supply; Please add IK behind order no.

Sauter-Revolver DIN 5480	=	CTXR
Sauter-Revolver DIN 5482 17 x 14	=	5482
Diplomatic DIN 1809	=	1809
Baruffaldi TOEM 200	=	TOEM
Beispiel / Example: 80.4020 WN TOEM		

Radial Gewindebohrkopf achsversetzt

Radial tapping head offset

Tête de taraudage radial

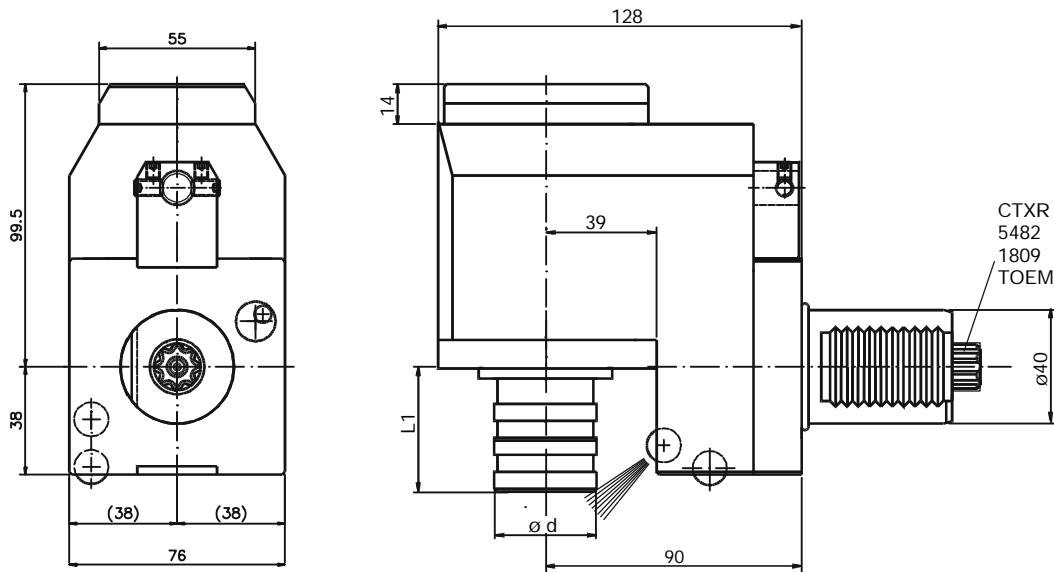

Bestell Nr Order No.	i	d	L ₁	n _{max} [1/min]	T _{max} [Nm]	Gewindebohraufnahme Tapping adaptor
81.4012 ...	1:1	36	45	5000	50	WFLK 1 (M3-M10)
81.4020 ...	1:1	53	68	5000	50	WFLK 2 (M8-M12)

Sauter-Revolver DIN 5480 = CTXR
 Sauter-Revolver DIN 5482 17 x 14 = 5482
 Diplomatic DIN 1809 = 1809
 Baruffaldi TOEM 200 = TOEM
 Beispiel / Example: 81.4012 5482

Radial Bohr- und Fräskopf zurückgesetzt

Radial drilling and milling head offset

Tête de perçage et fraisage radial

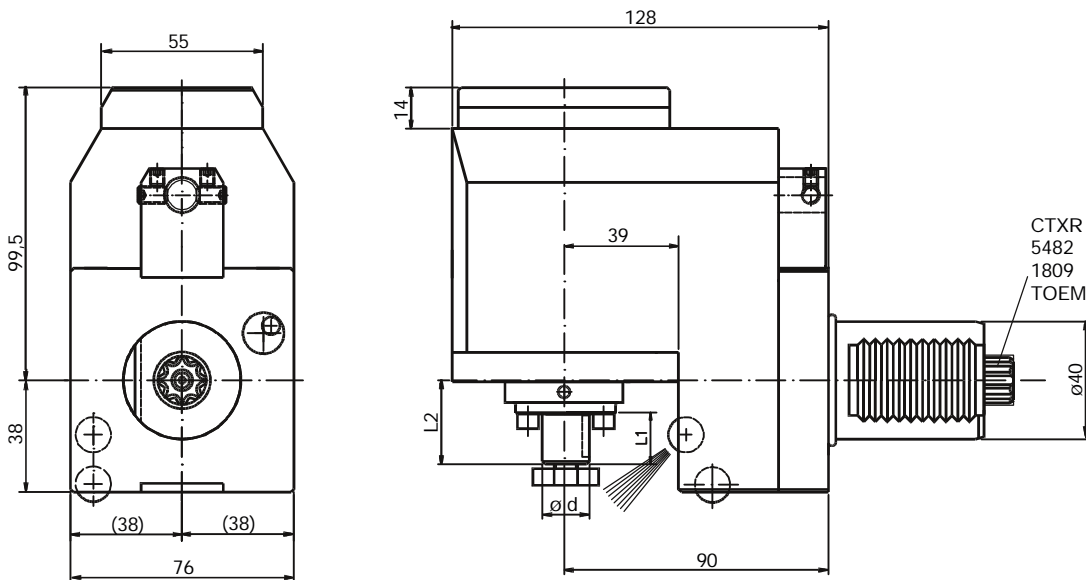

Bestell Nr Order No.	i	d	L ₁	L ₂	n _{max} [1/min]	T _{max} [Nm]
82.4016 ...	1:1	16	17,5	28,5	5000	50
82.4022 ...	1:1	22	19	30	5000	50
82.4027 ...	1:1	27	19	30	5000	50
82.4016 .../3	3:1	16	Maße auf Anfrage			120
82.4022 .../3	3:1	22	Dimensions sur demande			120
82.4027 .../3	3:1	27				120

Sauter-Revolver DIN 5480 = CTXR
 Sauter-Revolver DIN 5482 17 x 14 = 5482
 Diplomatic DIN 1809 = 1809
 Baruffaldi TOEM 200 = TOEM
 Beispiel / Example: 82.4027 1809

Schwenkkopf
± 105°

Swivel head
± 105°

Tête pivotante
± 105°

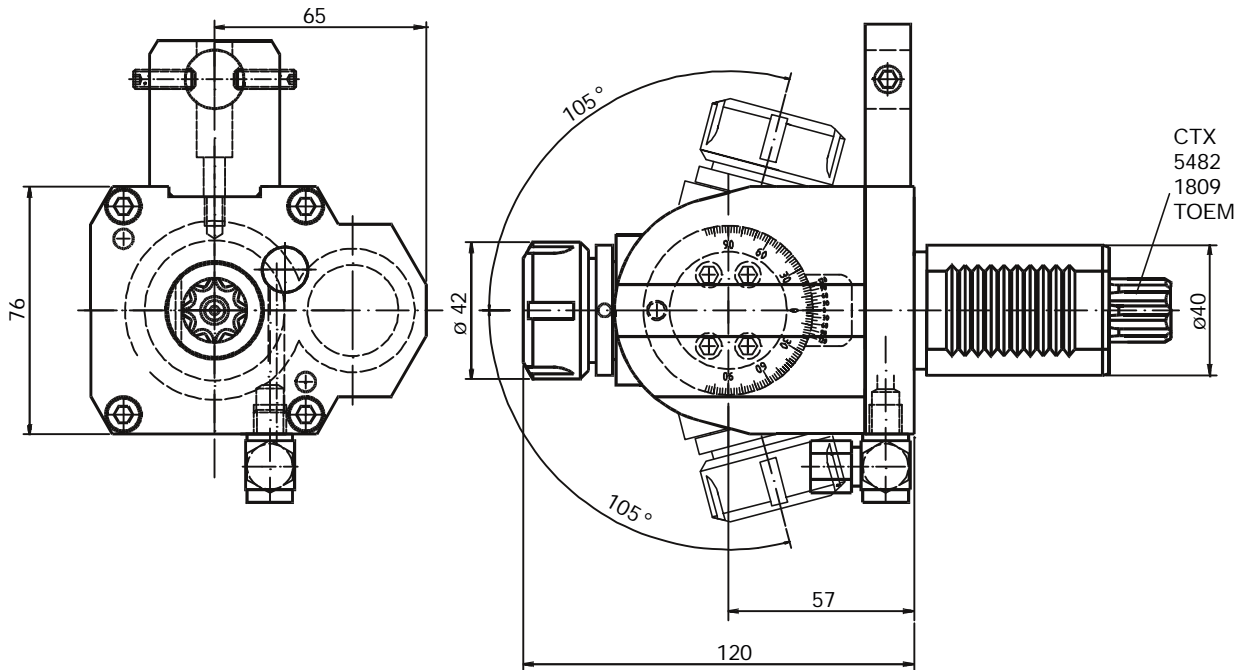

3

Bestell Nr Order No.	i	Schlüsselsatz Wrench-set	Spannzange (siehe 1.27) Collet (see 1.27)	Sauter-Revolver DIN 5480 = CTX Sauter-Revolver DIN 5482 17 x 14 = 5482 Diplomatic DIN 1809 = 1809 Baruffaldi TOEM 200 = TOEM Beispiel / Example: 63.4025 5482
63.4025 ...	1:1	225/DIN 1810B 40-45	RD/ER 25 430E (M3-M10)	

Radial Scheiben-
fräserkopf

Radial drilling head
for side milling cutters

Tête de fraisage radial
pour fraise scie

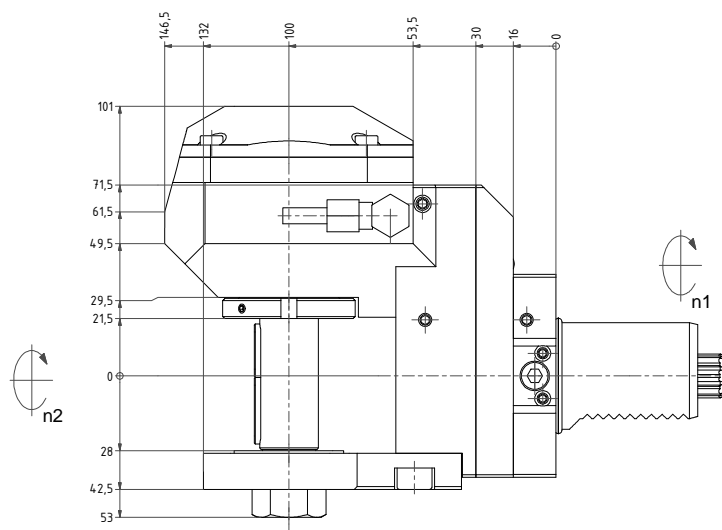

Bestell Nr Order No.	i	d	n _{max} [1/min]	T _{max} [Nm]	Sauter-Revolver DIN 5480 = CTX Sauter-Revolver DIN 5482 17 x 14 = 5482 Diplomatic DIN 1809 = 1809 Baruffaldi TOEM 200 = TOEM Beispiel / Example: 64.4016 5482
64.4016 ...	3:1	16	2000	50	
64.4022 ...	3:1	22	2000	50	



Werkzeuge für Index / Traub Maschinen

Tools for Index / Traub machines
Porte-outils pour machines Index / Traub

Werkzeughalter für Index / Traub Maschinen
Toolholder for Index / Traub Machines
Porte-outil por machines Index / Traub

			Page
DIN 69 880 Ø20	DIN 69 880 Ø20	DIN 69 880 Ø20	4.1 - 4.5
DIN 69 880 Ø30	DIN 69 880 Ø30	DIN 69 880 Ø30	4.11 - 4.21
DIN 69 880 Ø40	DIN 69 880 Ø40	DIN 69 880 Ø40	4.31 - 4.36
DIN 69 880 Ø50	DIN 69 880 Ø50	DIN 69 880 Ø50	4.41
DIN 69 880 Ø25 für Maschinentyp G200/G160/C42/65	DIN 69 880 Ø25 to suit G200/G160/C42/65	DIN 69 880 Ø25 pour Tour G200/G160/C42/65	4.61 - 4.70.8
DIN 69 880 Ø25 für Maschinentyp ABC	DIN 69 880 Ø25 to suit ABC	DIN 69 880 Ø25 pour Tour ABC	4.71 - 4.79.8
DIN 69 880 Ø30 für Maschinentyp G300/G250	DIN 69 880 Ø30 to suit G300/G250	DIN 69 880 Ø30 pour Tour G300/G250	4.80 - 4.90.7
DIN 69 880 Ø30 für TND300G/TNC42/TNC65	DIN 69 880 Ø30 to suit TND300G/TNC42/TNC65	DIN 69 880 Ø30 pour Tour TND300G/TNC42/ TNC65	4.130 - 4.140.4



Statische Werkzeuge für Index-Maschinen

Static tools for Index machines
Porte-outils pour machines Index

Bohrhalter

für INDEX

Drill Holder

for INDEX

Porte-outil

pour INDEX

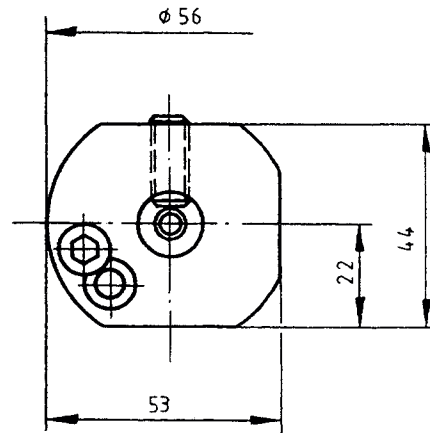
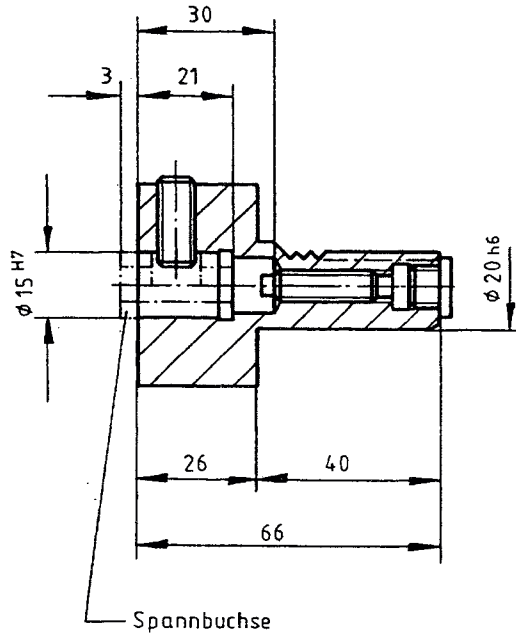

Nr. / No.
20.250
210.0000

Bohrhalter

für INDEX

Drill Holder

for INDEX

Porte-foret

pour INDEX

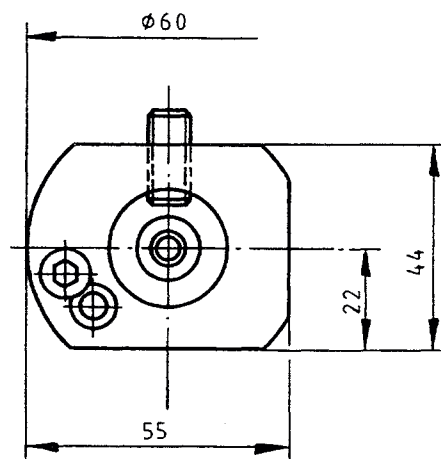
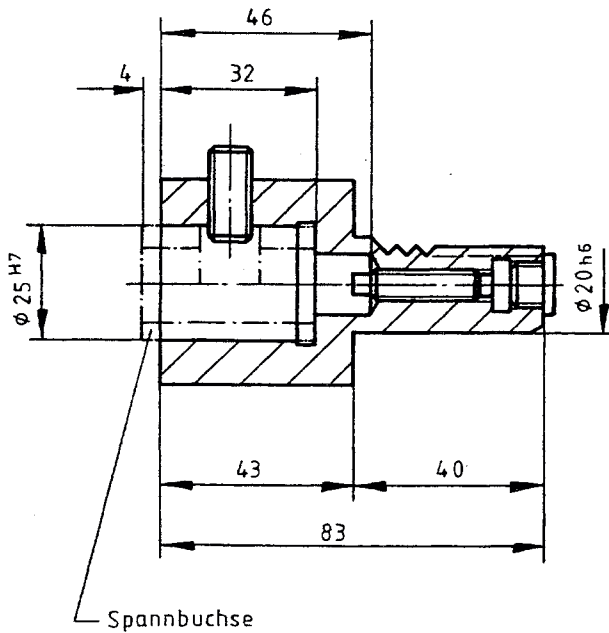

Nr. / No.
20.250
210.0025

Ausdrehalter

mit Höheneinstellung für INDEX

Boring Tool Holder

with Height Adjustment for INDEX

Porte-outil d'alésage

avec hauteur réglable pour INDEX

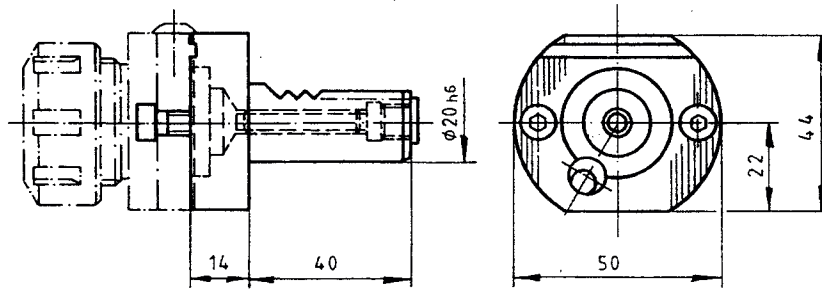

Nr. / No.

20.600
220.1000

Ausdrehaltestück

für INDEX

Boring Tool Block

for INDEX

Support d'alésage

pour INDEX

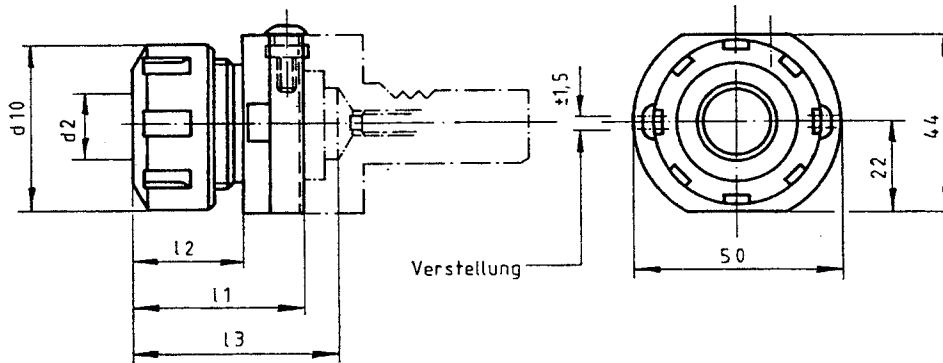

Nr. / No.	Maße/Dimensions Spannbereich / Collet Range Capacité serrage d ₂				Spannzange / Collets Pince de serrage Nr.	
	d ₁₀	l ₁	l ₂	l ₃		
20.650 220.1010	28	36	20	44	BER 16 426 E	
20.650 220.1020	42	41	25	49	BER 25 430 E	

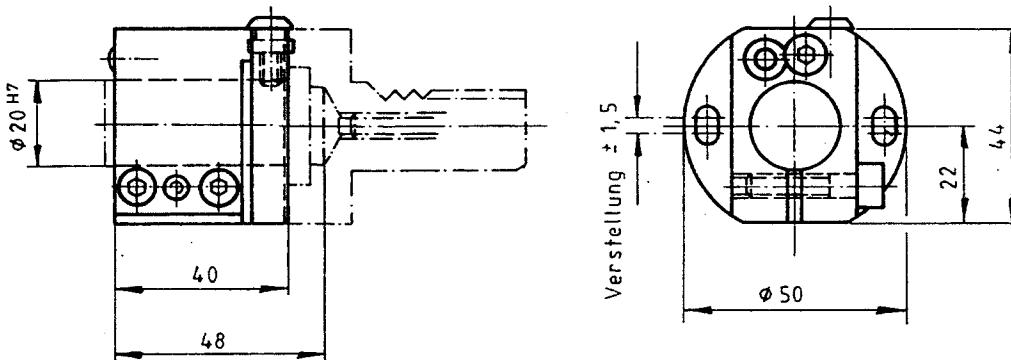

Nr. / No.

20.650
220.1030

Ausdrehhalter

vorgearbeitet, für INDEX

Boring Tool Holder

blank, for INDEX

Porte-outil d'alésage

e'bauche, pour INDEX

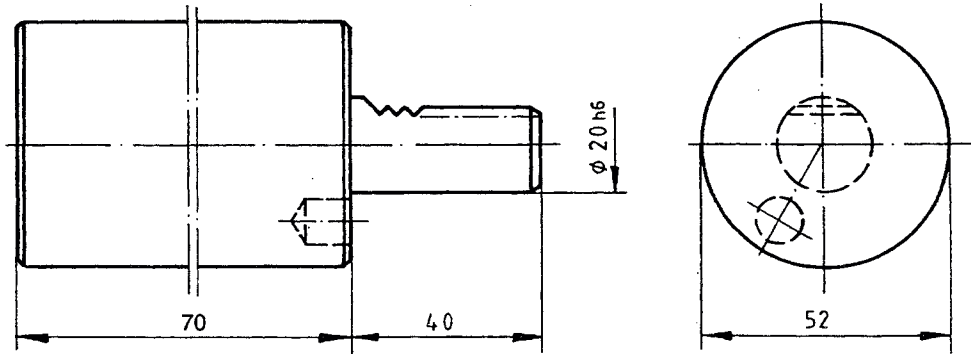

Nr. / No.
R 20.52.70

Ausdrehhalter

für INDEX

Boring Tool Holder

for INDEX

Porte-outil d'alésage

pour INDEX

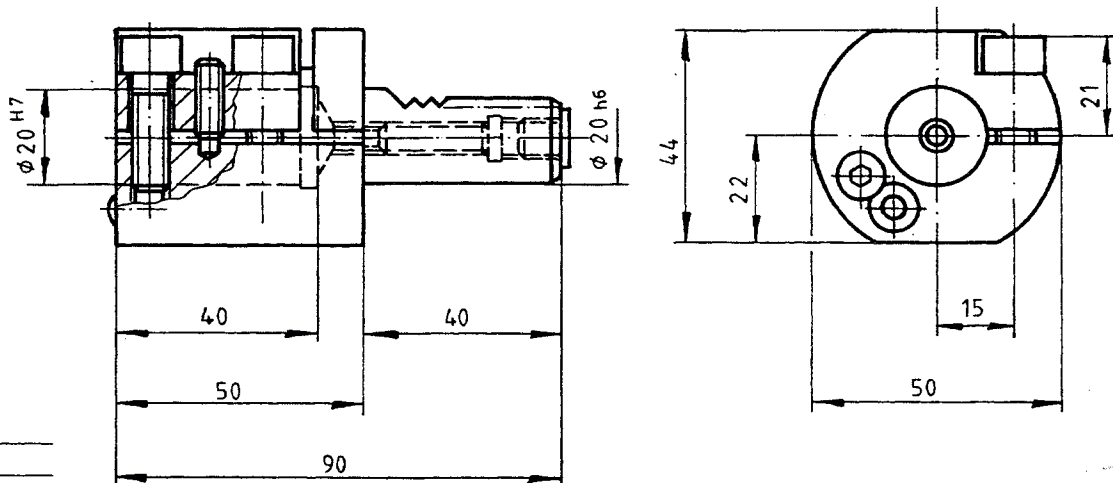

Nr. / No.
20.250
220.0100

Aufnahmebüchsen

für INDEX

Adaptor Bushes

for INDEX

Douille

pour INDEX

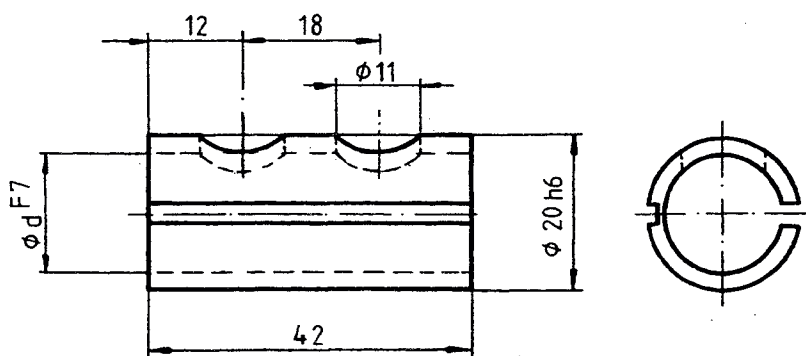

Nr. / No.	d ^{F7}
400.108.20.42	8
400.110.20.42	10
400.112.20.42	12
400.115.20.42	15
400.115,87.20.42	5/8"
400.16.20.40	16

Bohr- und Ausdrehhalter

für INDEX

**Drilling and Boring
Tool Holder**

for INDEX

**Porte-outil et
Porte-outil d'alésage**

pour INDEX

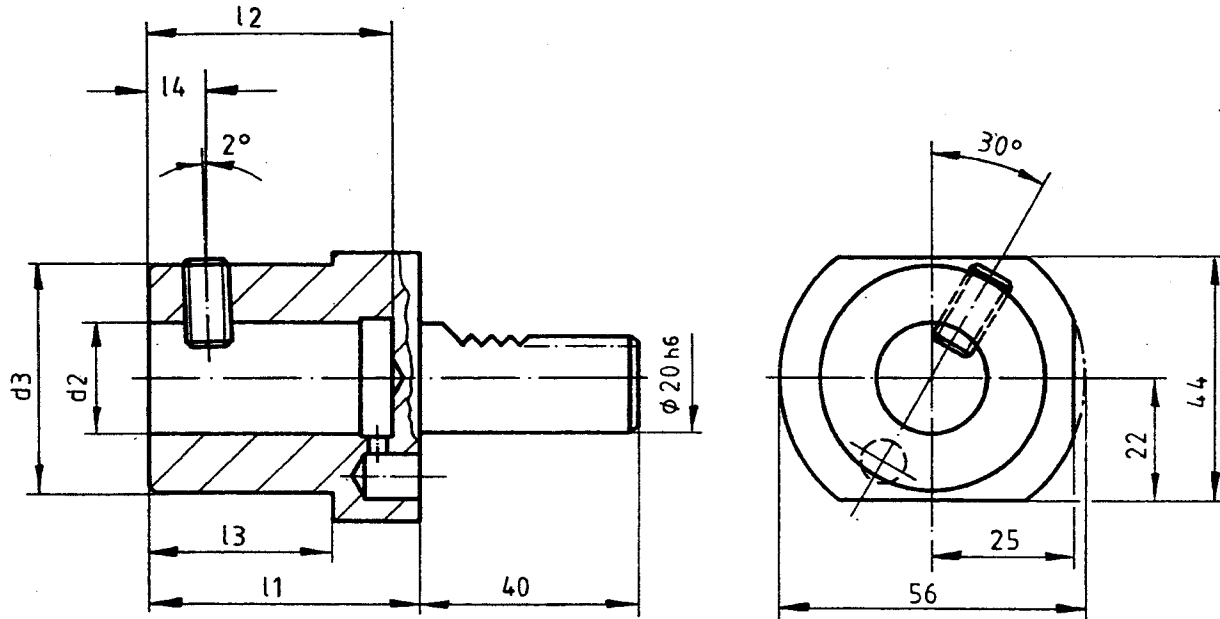

Nr. / No.	Maße / Dimensions					
	d2	d3	l1	l2	l3	l4
220.4000	20	42	48	43	32	10
220.4100	25	42	56,5	48	40	12

Aufnahmehülsen

für INDEX

Adaptor Bushes

for INDEX

Douille de réduction

pour INDEX

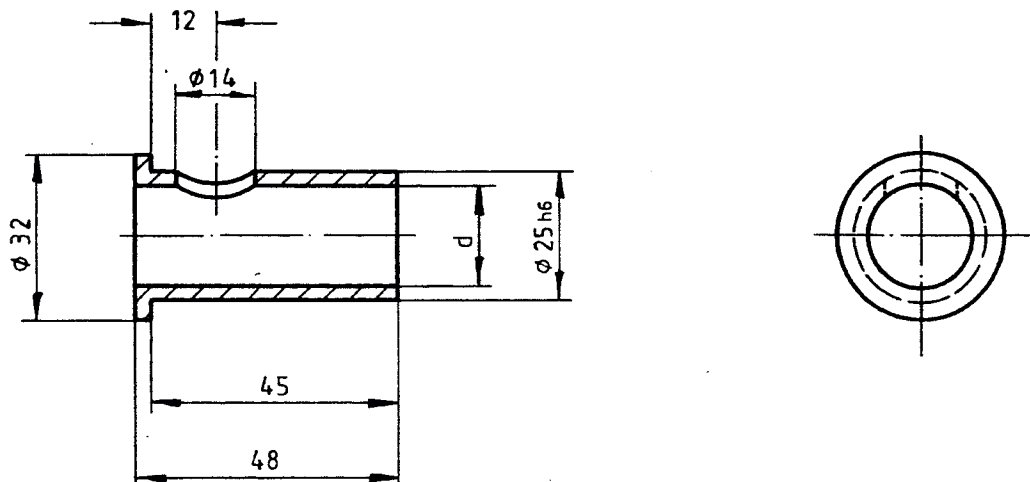

Nr. / No.	d
220.4116	16 ^{H7}
220.4120	20 ^{H7}

Ausgleichhalter

für INDEX

Tool Holder Adaptor

for INDEX

Adaptateur

pour INDEX

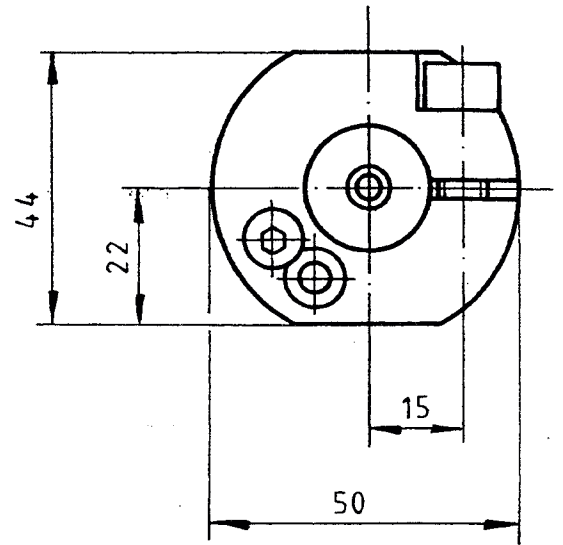
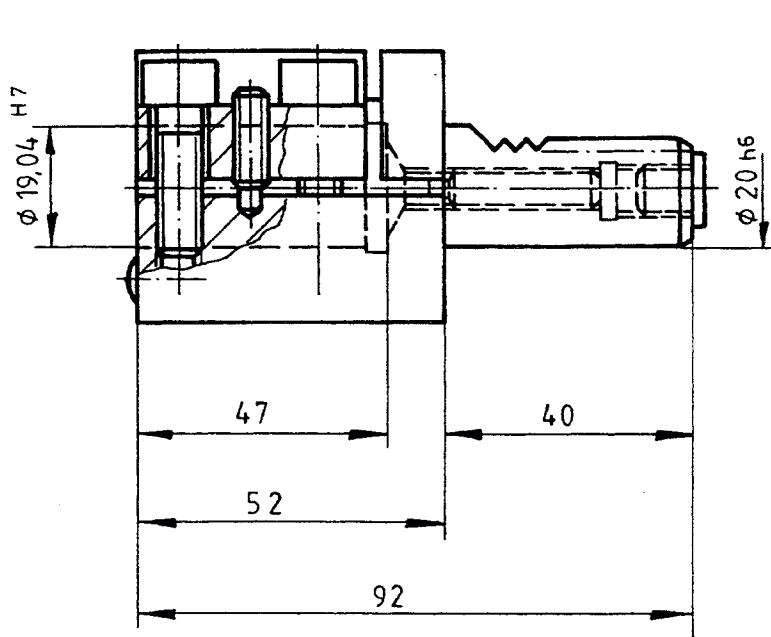

Nr. / No.
20.250
520.0000

4

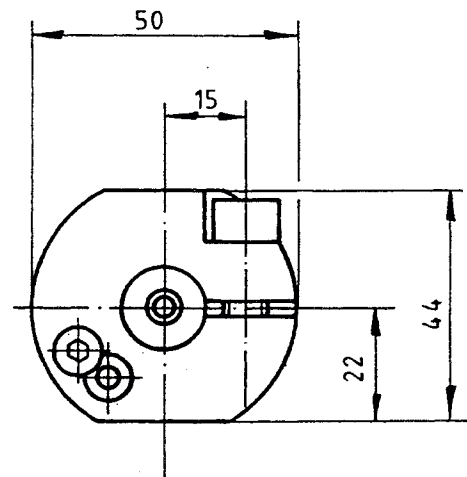
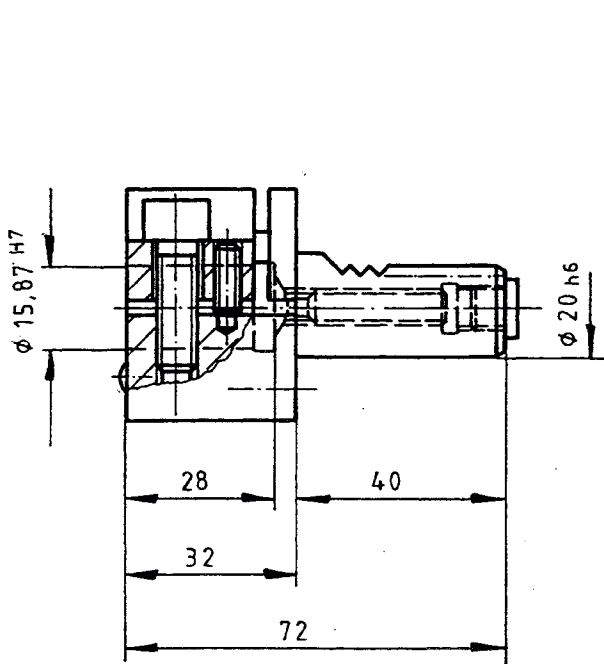

Nr. / No.
20.250
520.0100



Bohrhalter

für INDEX

Drill Holder

for INDEX

Porte-outil

pour INDEX

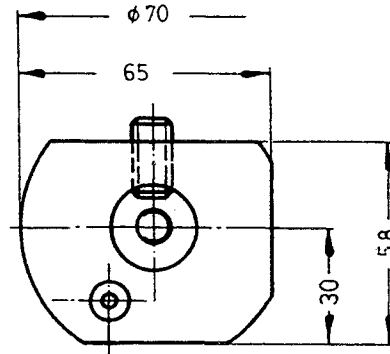
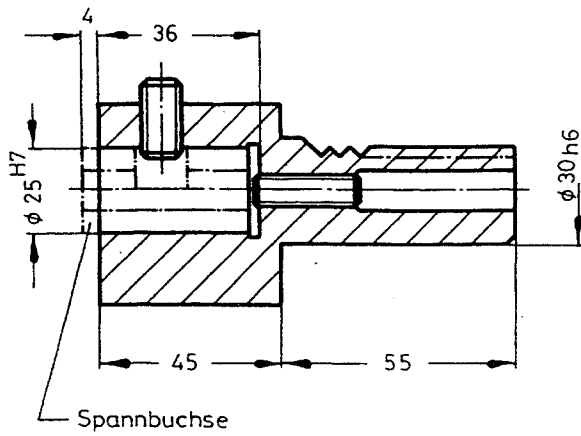

Nr. / No.

25.250

211.0000

Spannbüchsen Druckstöcke

für INDEX

Clamping Bush Pressure Pads

for INDEX

Douille de serrage Cale

pour INDEX

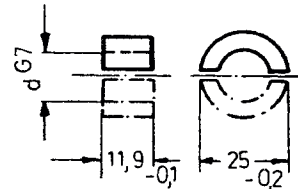
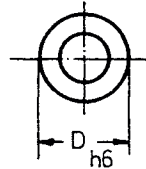
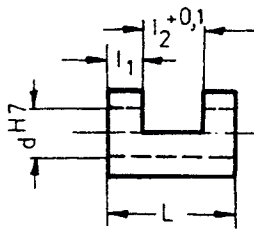

Maße / Dimensions

D	L	l ₁	l ₂
25	36	12	12

Nr. / No.

	d
125.0500	5
125.0600	6
125.0700	7
125.0800	8
125.0900	9
125.1000	10
125.1100	11
125.1200	12
125.1300	13
125.1400	14
125.1500	15
125.1600	16
125.1700	17
125.1800	18
125.1900	19
125.2000	20

Maße / Dimensions

D	L	l ₁	l ₂
32	40	13	14

Nr. / No.

	d
132.1400	14
132.1500	15
132.1600	16
132.1700	17
132.1800	18
132.1900	19
132.2000	20
132.2200	22
132.2400	24
132.2500	25
132.2600	26

Nr. / No.

	d
825.0500	5
825.0600	6
825.0700	7
825.0800	8
825.0900	9
825.1000	10

Ausdrehalter

für INDEX

Boring Tool Holder

for INDEX

Porte-outil d'alésage

pour INDEX

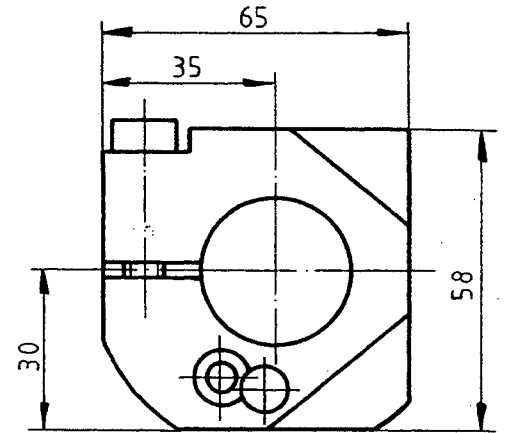
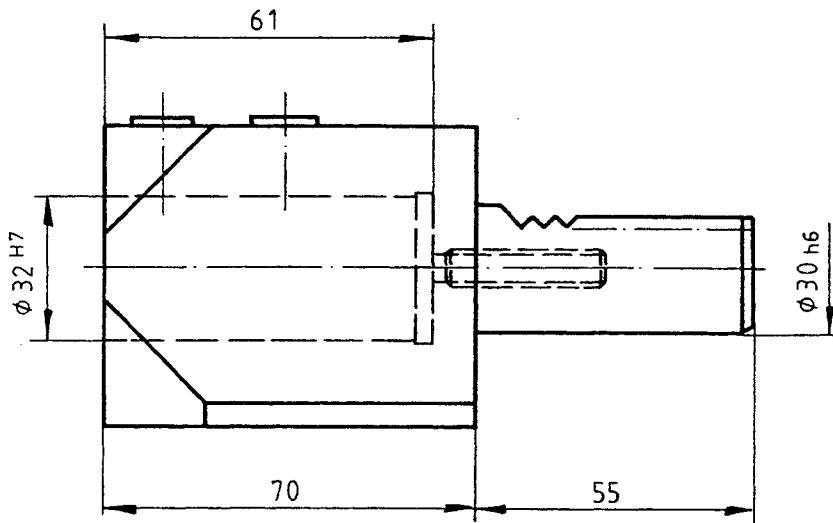

Nr. / No.
25.250
222.0200

Ausdrehalter

10 mm außermittig
für INDEX

Boring Tool Holder

10 mm off centre
for INDEX

Porte-outil d'alésage

10 mm du centre
pour INDEX

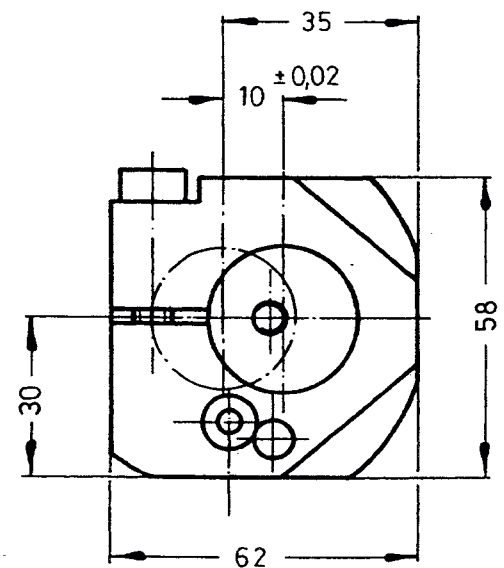
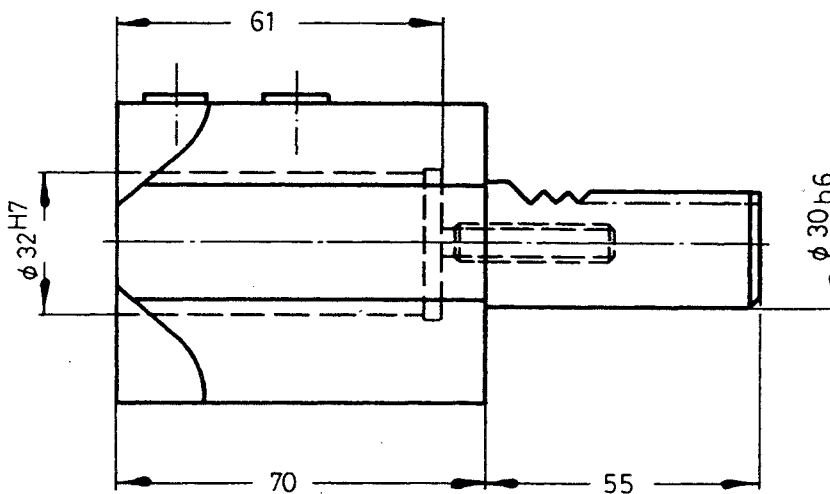

Nr. / No.
25.250
222.0300

Ausdrehhalter

für INDEX

Boring Tool Holder

for INDEX

Porte-outil d'alésage

pour INDEX

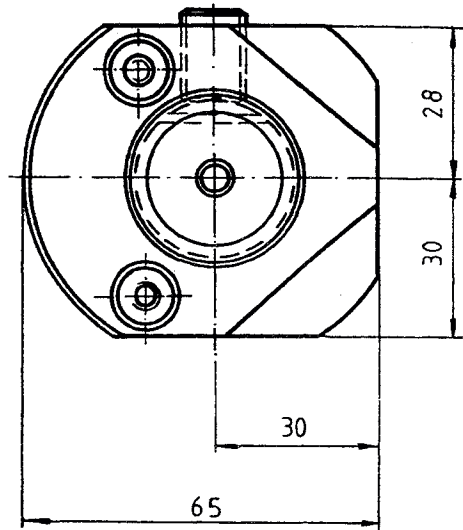
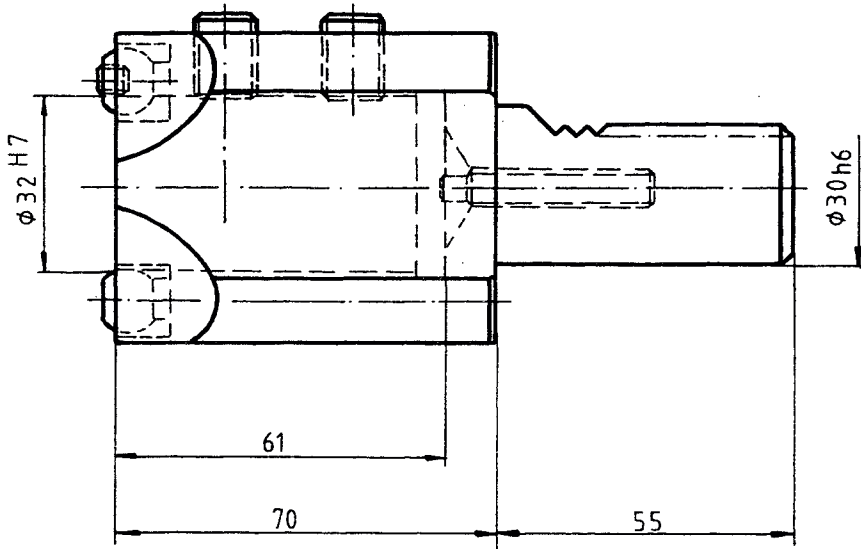

Nr. / No.
25.250
221.0600

Ausdrehhalter

10 mm außermittig
für INDEX

Boring Tool Holder

10 mm off centre
for INDEX

Porte-outil d'alésage

10 mm du centre
pour INDEX

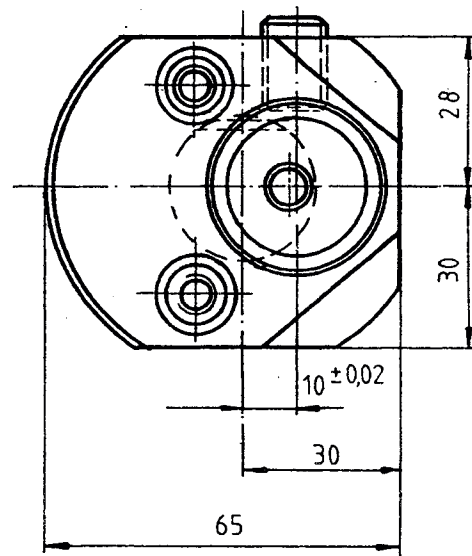
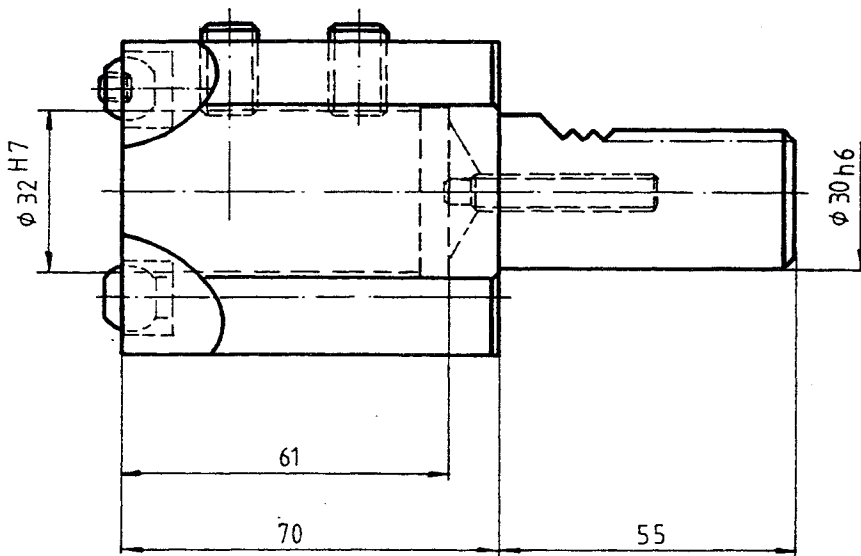

Nr. / No.
25.250
221.0700

Ausdrehhalter

mit Höhenverstellung
für INDEX

Boring Block Holder

with height adjustment
for INDEX

Porte-outil d'alésage

avec hauteur réglable
pour INDEX

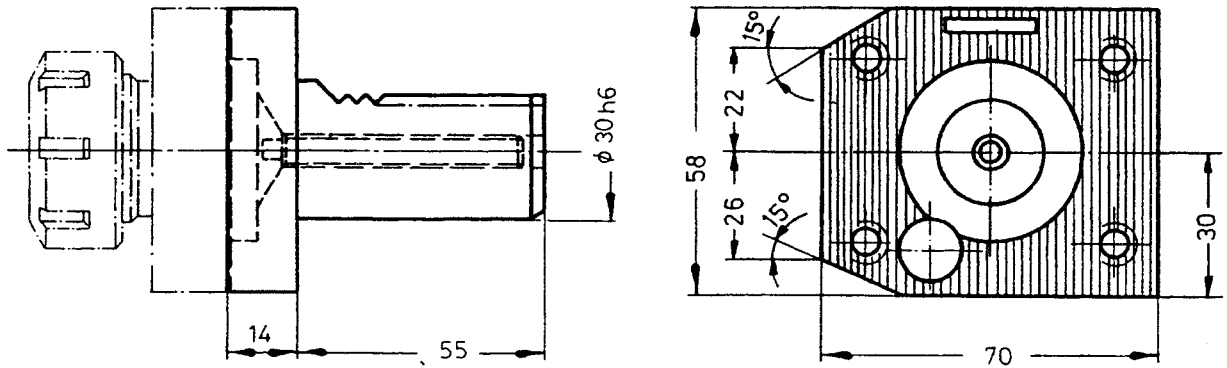

Nr. / No.
25.600
221.1000

Ausdrehhaltestück

für INDEX

Boring Block

for INDEX

Support d'alésage

pour INDEX

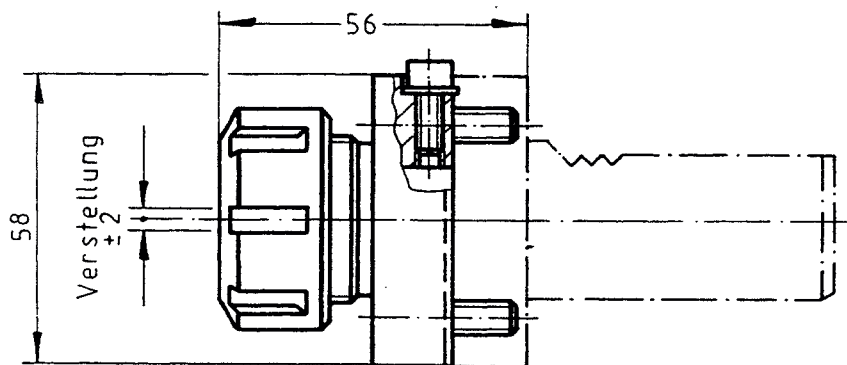

Nr. / No.	Spannzange Collets Pince de serrage	Spannbereich Collet Range Capacité serrage
25.650 221.1010	BER 25 430 E	1 - 16

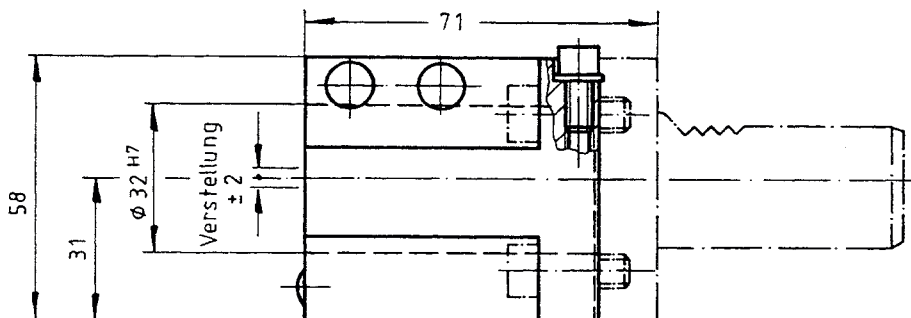

Nr. / No.
25.650
221.1020

Bohrhalter

für INDEX

Collet Chuck

for INDEX

Porte-outil

pour INDEX

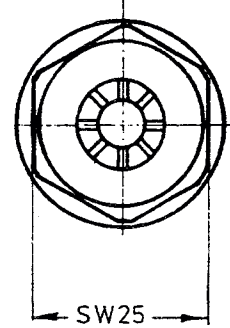
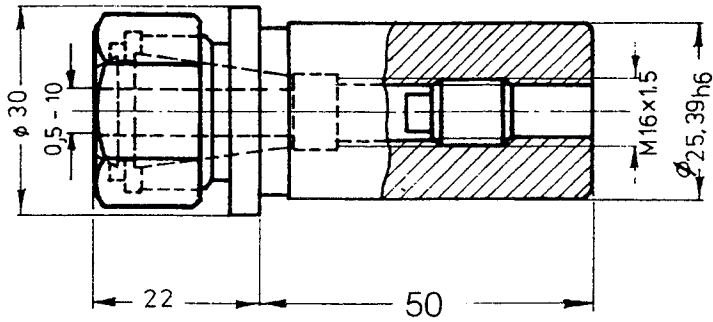

Nr. / No.	Spannzange Collets Pince de serrage	Spannbereich Collet Range Capacité serrage
100.1650	160 426 E	0,5 - 10

4

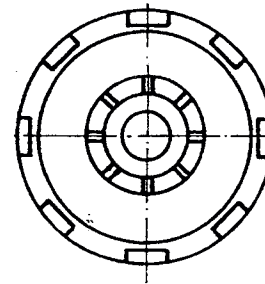
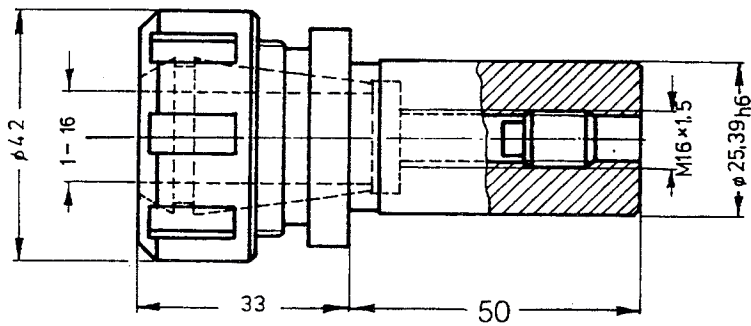

Nr. / No.	Spannzange Collets Pince de serrage	Spannbereich Collet Range Capacité serrage
100.2550	250 430 E	1 - 16

Ausgleichhalter

für INDEX

Tool Holder Adaptor

for INDEX

Adaptateur

pour INDEX

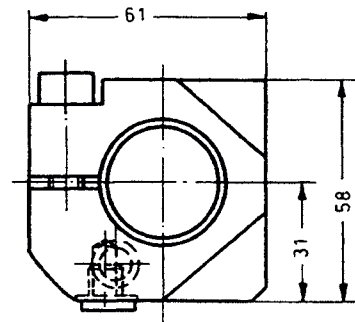
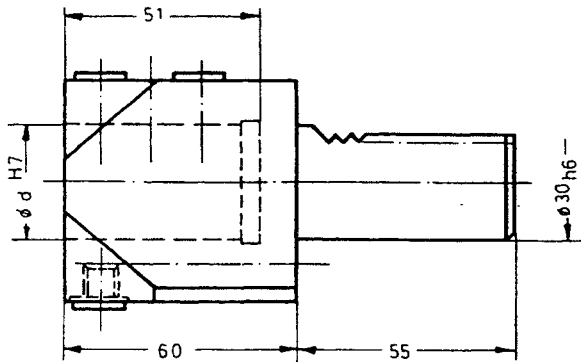

Nr. / No.	d
25.250	31,75
521.0000	
25.250	25,4
521.0100	

Ausgleichsbüchse

für INDEX

Adaptor Bush

for INDEX

Douille d'adaptation

pour INDEX

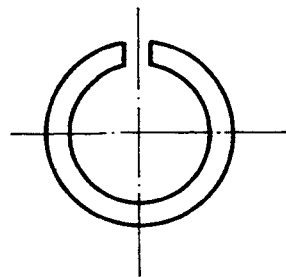
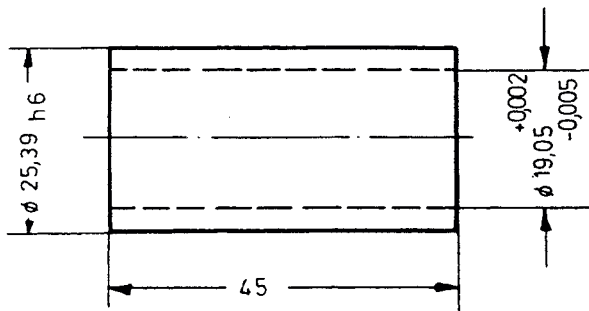

Nr. / No.
200.1905

Ausgleichsbüchse

für INDEX

Adaptor Bush

for INDEX

Douille d'adaptation

pour INDEX

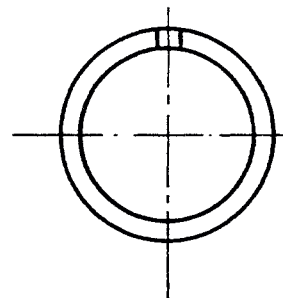
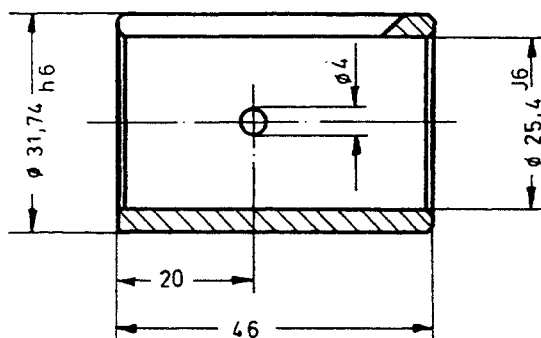

Nr. / No.
752

Aufnahmebüchsen

für INDEX

Adaptor Bush

for INDEX

Douille

pour INDEX

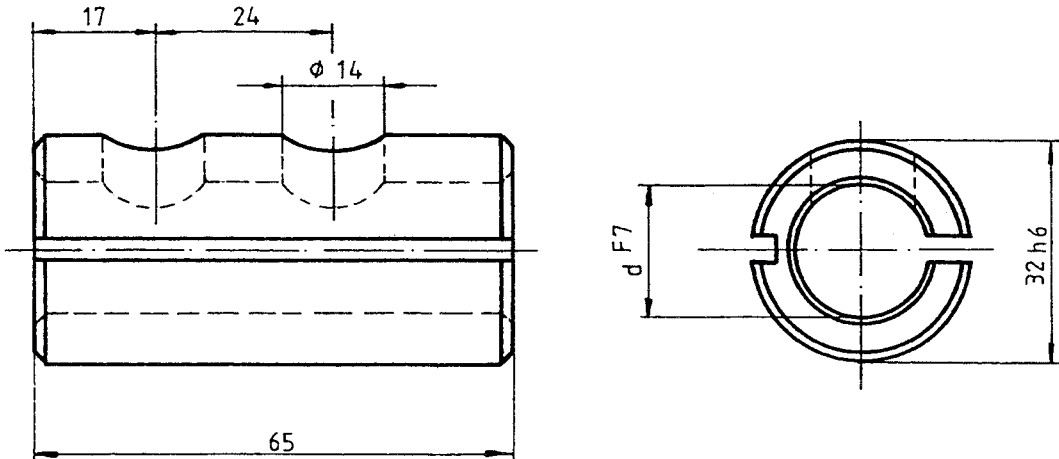

Nr. / No.	d
400.108.32.65	8
400.110.32.65	10
400.112.32.65	12
400.112,7.32.65	12,7 (1/2")
400.114.32.65	14
400.115.32.65	15

Nr. / No.	d
400.116.32.65	16
400.118.32.65	18
400.119,05.32.65	19,05 (3/4")
400.120.32.65	20
400.125.32.65	25
400.125,4.32.65	25,4 (1")

4

Ausgleichsbüchse

für INDEX

Adaptor Bush

for INDEX

Douille d'adaptation

pour INDEX

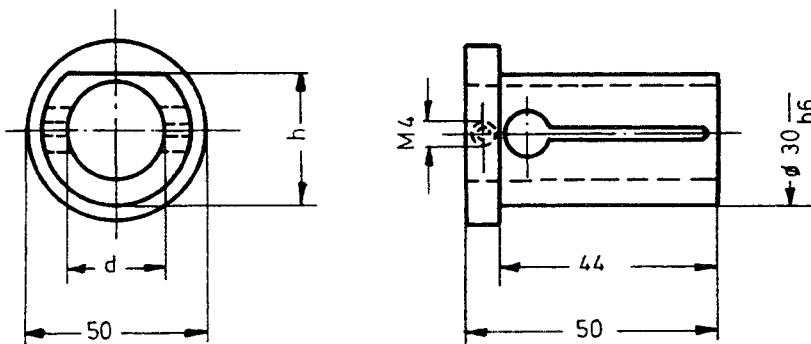

Nr. / No.	Maße / Dimensions	
	d	h
520.1905	19,05	27
520.2540	25,4	28,7

Werkstoffanschlag

mitlaufend Länge verstellbar
für INDEX

Stock Stop

revolving, length adjustable
for INDEX

Butée

longueur réglable
pour INDEX

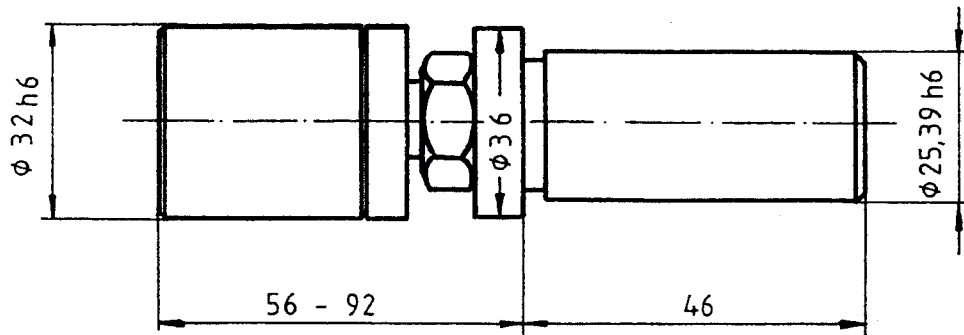

Nr. / No.

041.00

Werkstoffanschlag

mitlaufend, Länge verstellbar
für INDEX

Stock Stop

revolving, length adjustable
for INDEX

Butée

longueur réglable
pour INDEX

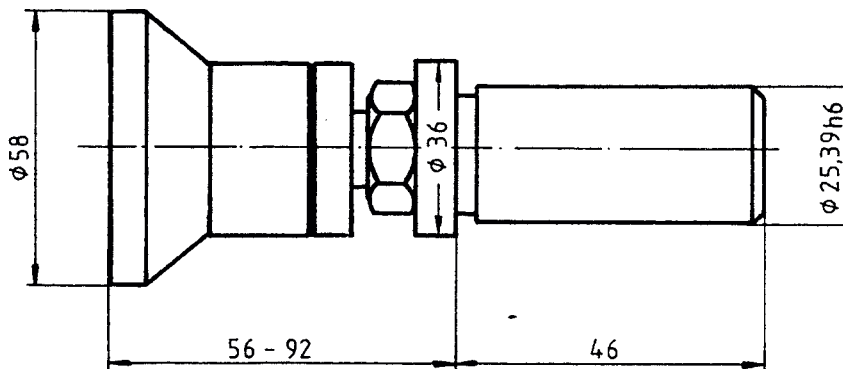

Nr. / No.

051.00

Bohrhalter

für INDEX

Drill Holder

for INDEX

Porte-outil

pour INDEX

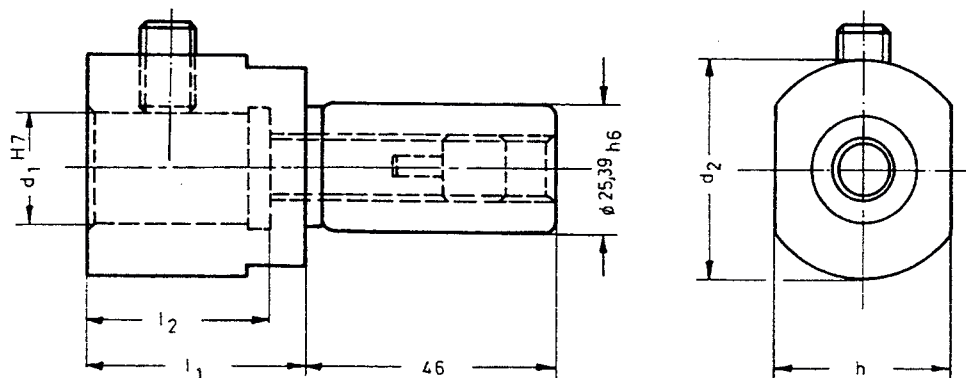

Nr. / No.	Maße / Dimensions				
	d_1	d_2	l_1	l_2	h
32.100.00	25	48	40	32	36
32.100.0002	32	60	44	36	46

Stechhalter

mit Höhenverstellung
für INDEX

**Infeed Tool Holder
(chasers)**

with height adjustment
for INDEX

Porte-outil de plongée

avec hauteur réglable
pour INDEX

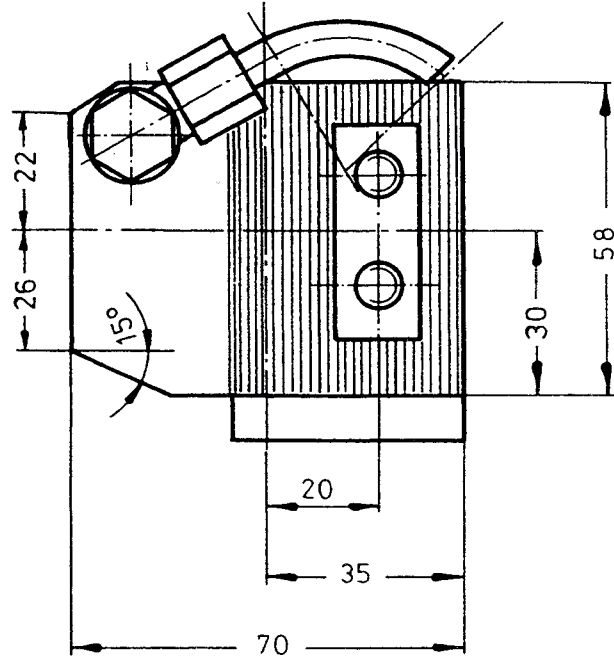
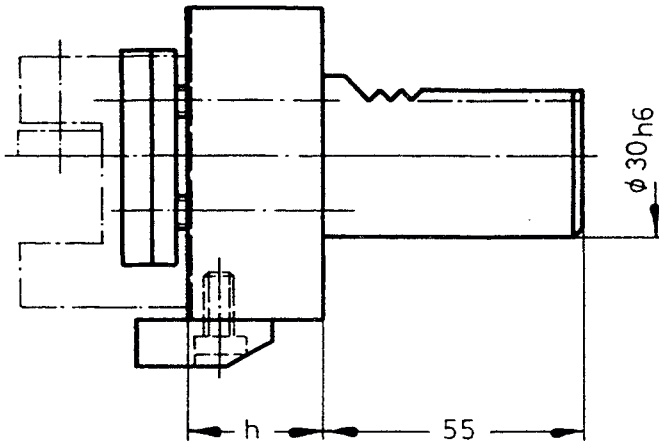

Nr. / No.	h
25.700	24
230.0000	
25.700	44
230.0100	

Stechhaltestück

für INDEX

Chaser Block

for INDEX

Support de plongée

pour INDEX

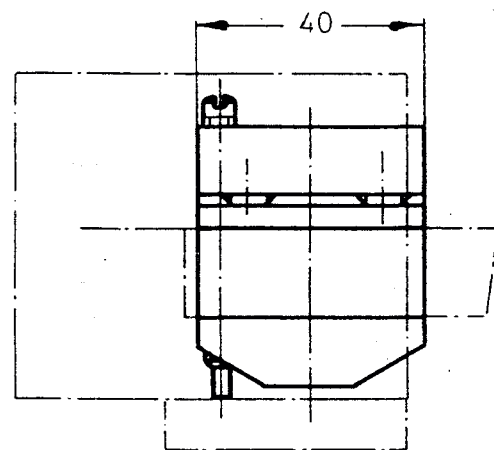
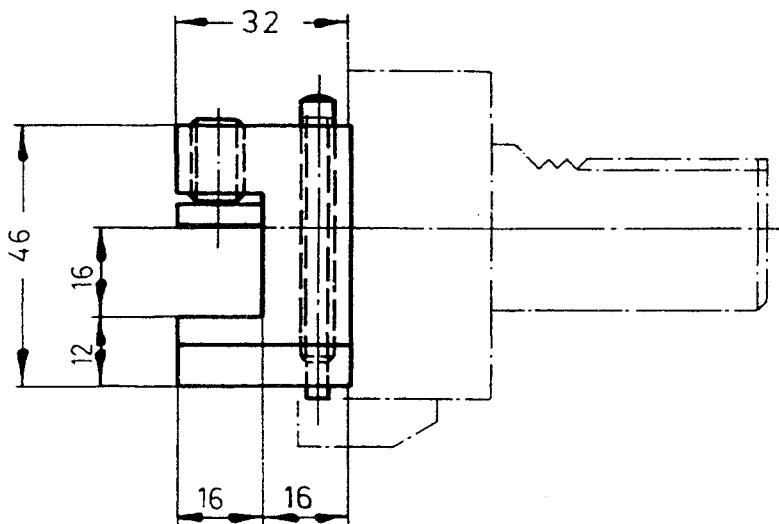

Nr. / No.
25.701
1661.10

Stechhaltestück

für INDEX

Chaser Block

for INDEX

Support de plongée

pour INDEX

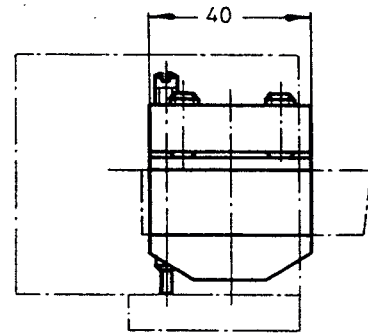
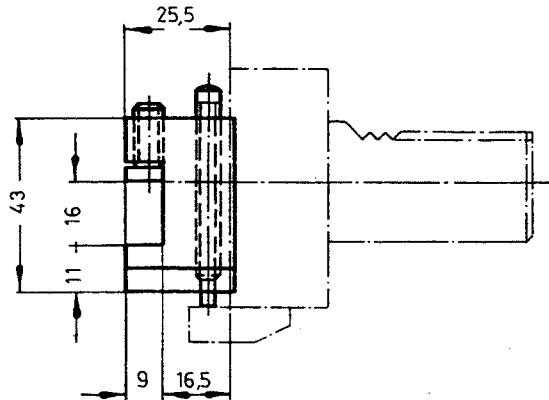

Nr. / No.
25.703
1661.30

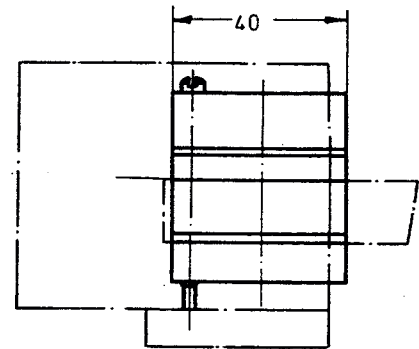
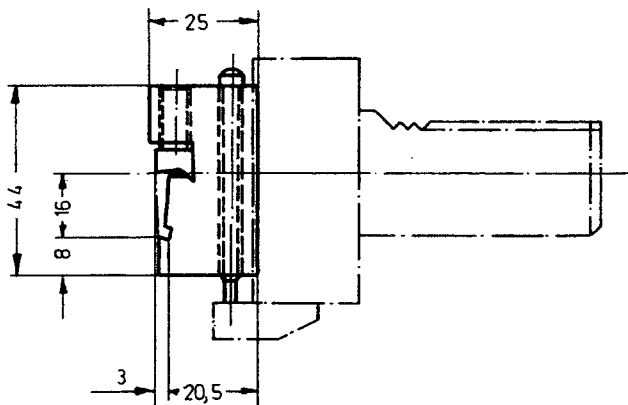

Nr. / No.
25.704
1661.40

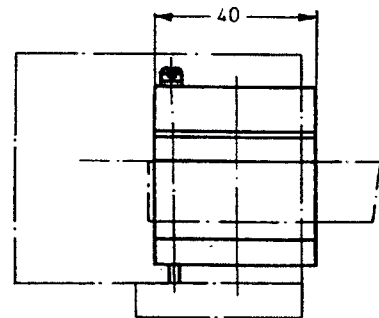
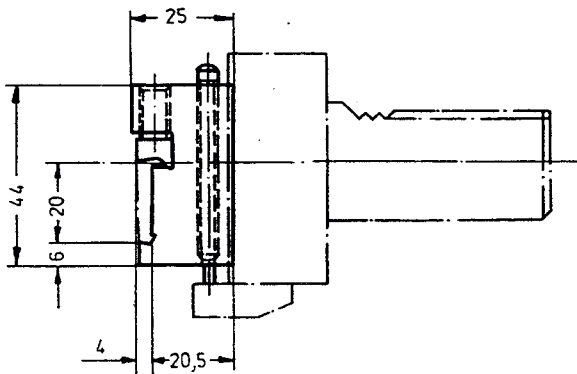

Nr. / No.
25.705
1661.70

Drehhalter

für Linkslauf für INDEX

**Turning Tool Holder,
square**

Left hand for INDEX

Porte-outil de tournage

Gauche pour INDEX

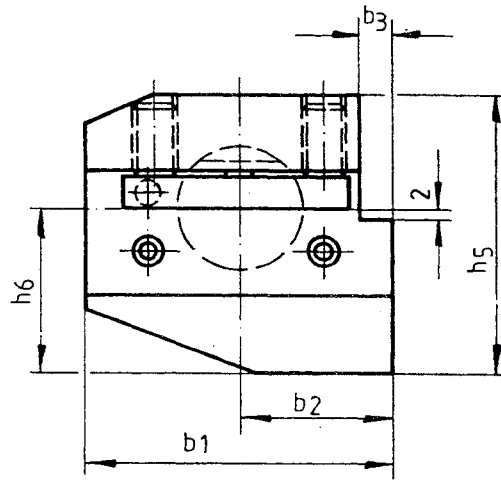
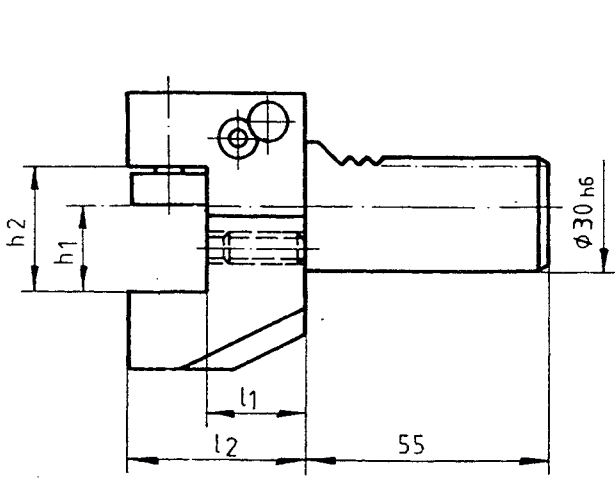

Nr. / No.	Maße / Dimensions								
	b ₁	b ₂	b ₃	h ₁	h ₂	h ₅	h ₆	l ₁	l ₂
25.101 301.0100	70	35	8	20	29	66	38	42	60
25.101 351.0025	72,5	42,5	7,5	25	34	71	43	22	45
25.101 301.0700	70	35	8	20	29	66	38	57	77

4

Drehhalter

für Rechtslauf für INDEX

**Turning Tool Holder,
square**

Right hand for INDEX

Porte-outil de tournage

Droite pour INDEX

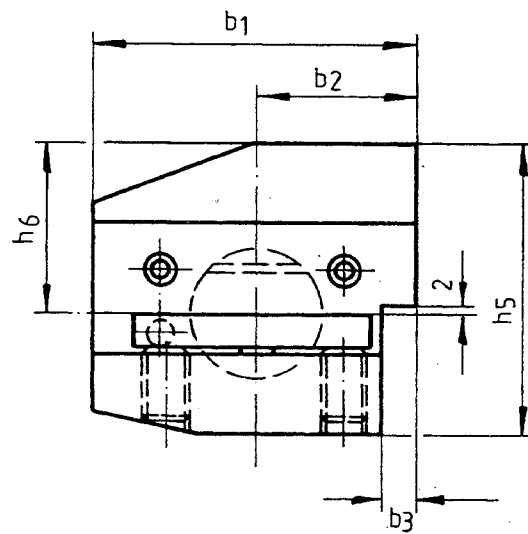
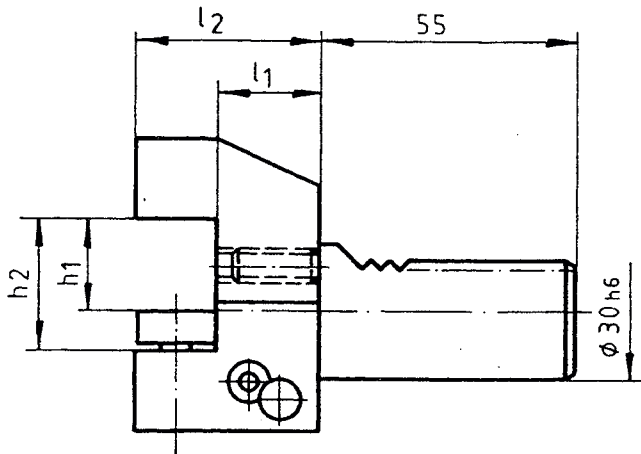

Nr. / No.	Maße / Dimensions								
	b ₁	b ₂	b ₃	h ₁	h ₂	h ₅	h ₆	l ₁	l ₂
25.100 301.0300	70	35	8	20	29	68	38	57	77
25.100 301.0225	70	35	8	25	34	73	43	22	46



Ausdrehhalter

10 mm außermittig
für INDEX

Boring Tool Holder

10 mm off centre
for INDEX

Porte-outil d'alésage

10 mm du centre
pour INDEX

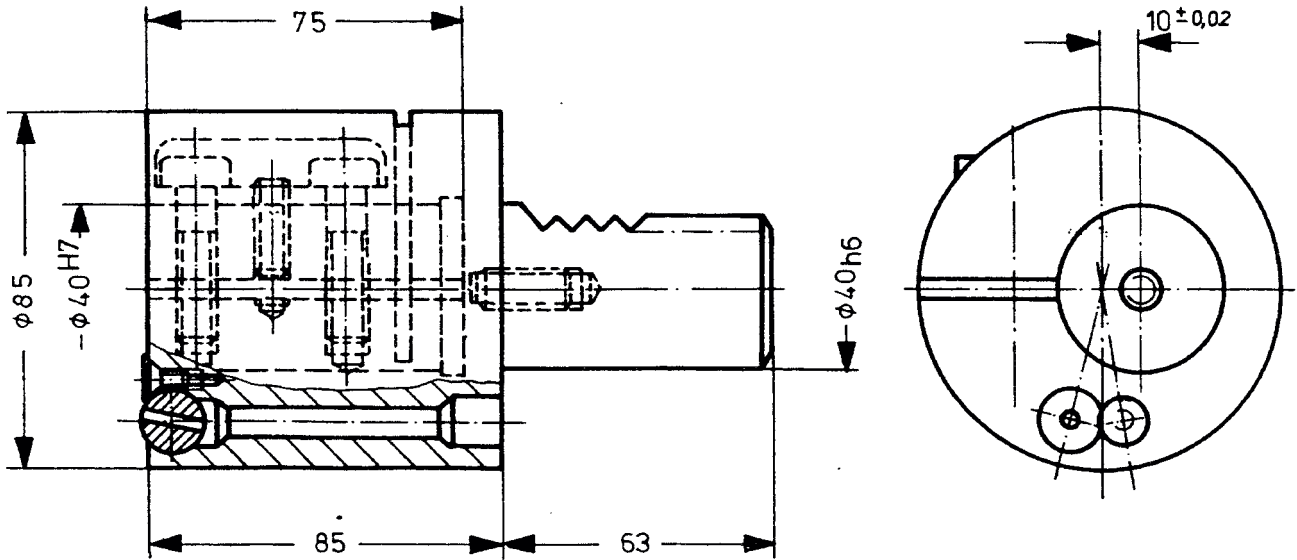

Nr. / No.
25.260
221.1400

Ausdrehhalter

für INDEX

Boring Tool Holder

for INDEX

Porte-outil d'alésage

pour INDEX

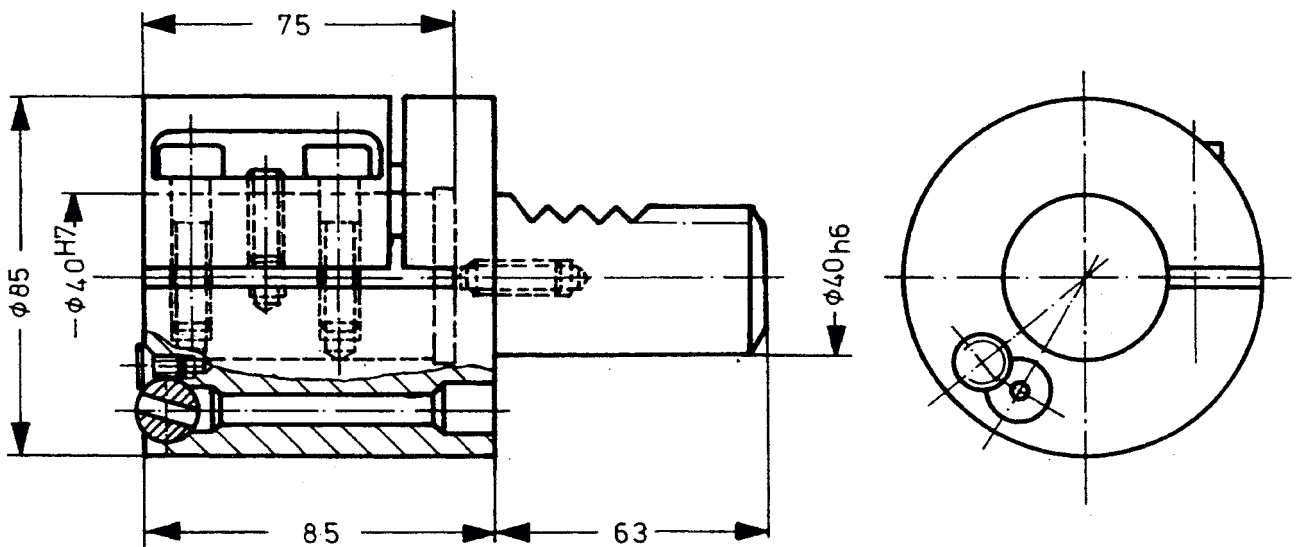

Nr. / No.
25.260
221.1500

Ausdrehalter

für INDEX

Boring Tool Holder

for INDEX

Porte-outil d'alésage

pour INDEX

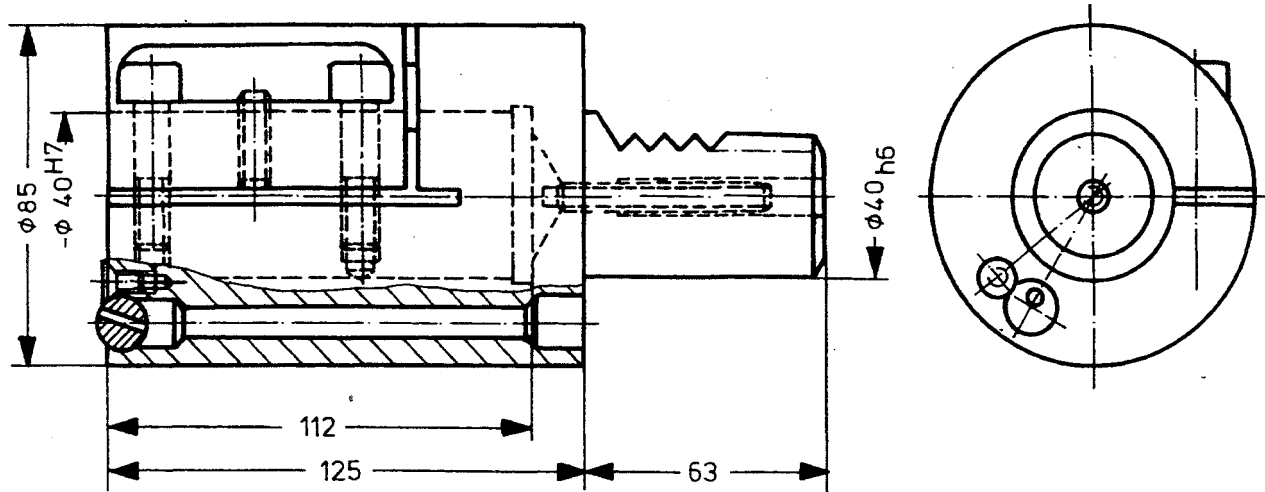

Nr. / No.
25.260
222.1600

Ausdrehalter

für INDEX

Boring Tool Holder

for INDEX

Porte-outil d'alésage

pour INDEX

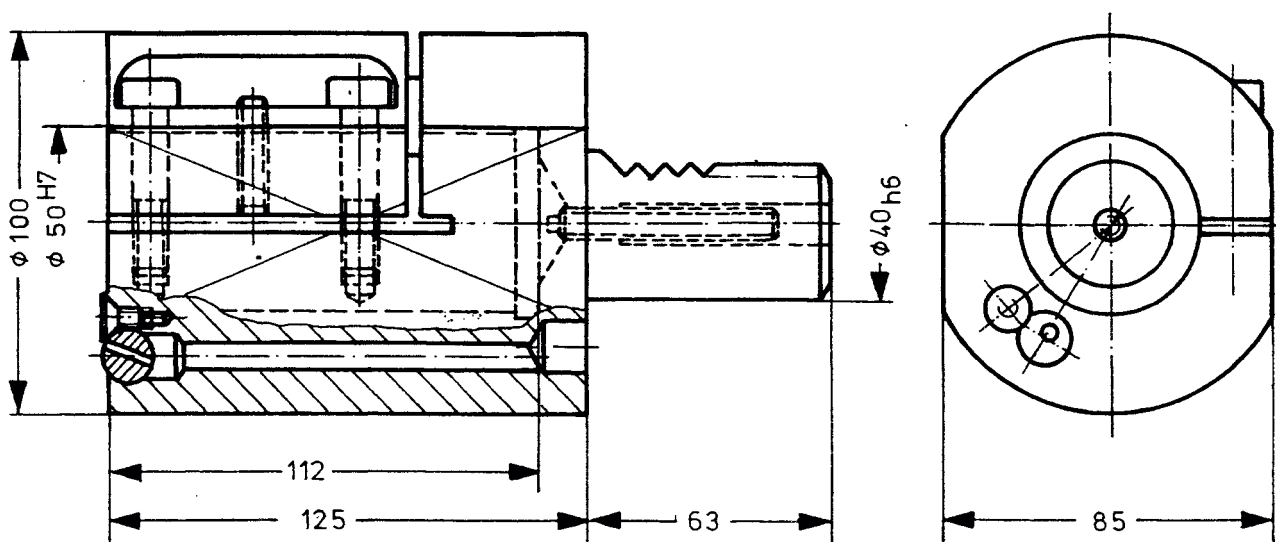

Nr. / No.
25.260
221.1700

Aufnahmebuchsen

für INDEX

Adaptor Bushes

for INDEX

Douille de réduction

pour INDEX

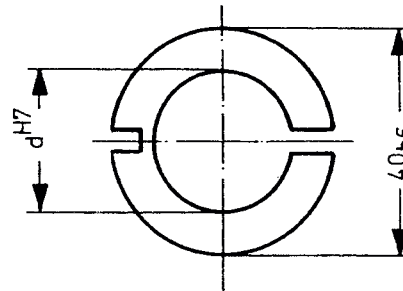
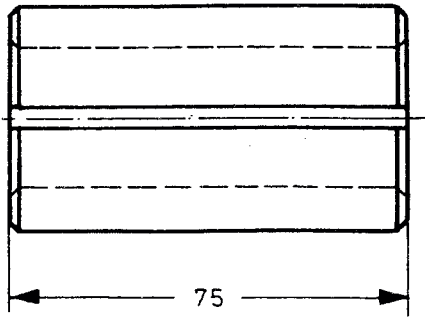

Nr. / No.	d
400.108.40.75	8
400.110.40.75	10
400.112.40.75	12
400.112,7.40.75	12,7 (1/2")
400.114.40.75	14
400.115.40.75	15
400.116.40.75	16

Nr. / No.	d
400.118.40.75	18
400.119,05.40.75	19,05 (3/4")
400.120.40.75	20
400.125.40.75	25
400.125,4.40.75	25,4 (1")
400.130.40.75	30
400.132.40.75	32

4

Aufnahmebuchsen

für INDEX

Adaptor Bushes

for INDEX

Douille de réduction

pour INDEX

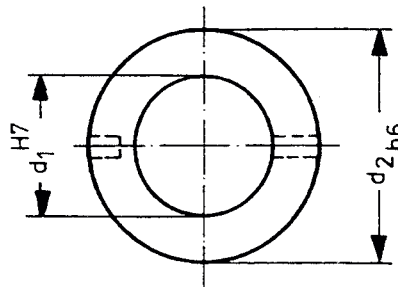
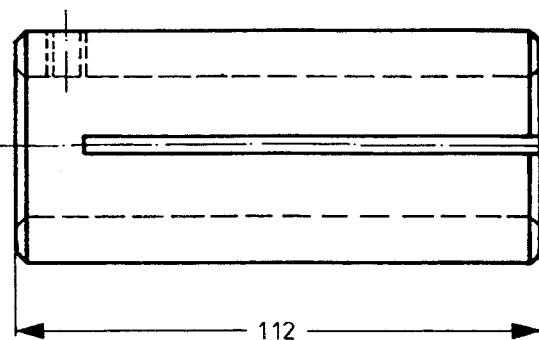

Nr. / No.	d ₁	d ₂
221.1616	16	40
221.1620	20	40
221.1625	25	40

Nr. / No.	d ₁	d ₂
221.1730	30	50
221.1732	32	50
221.1740	40	50

Drehhalter

für 32 Vierkant
für INDEX

Turning Tool Holder

for 32 mm square
for INDEX

Porte-outil de tournage

pour 32 mm carré
pour INDEX

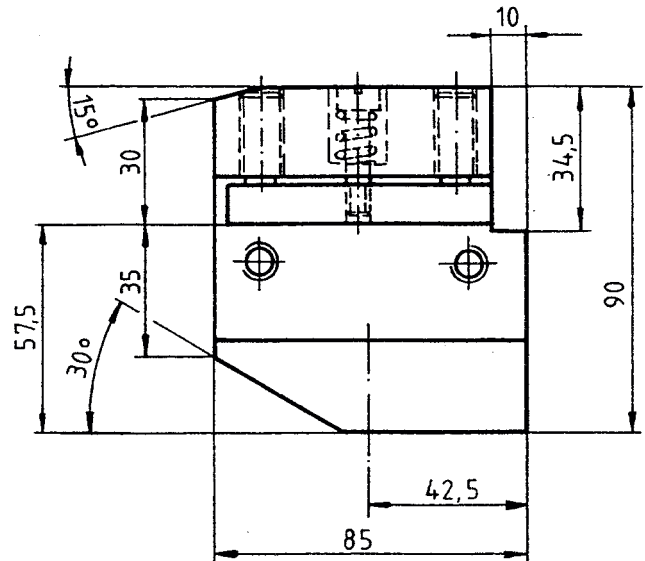
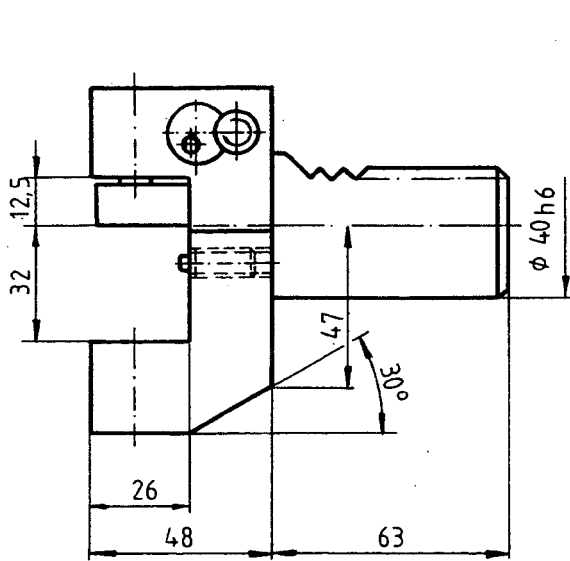

Nr. / No.

25.111

303.1000

Drehhalter

für 32 mm Vierkant
lange Ausführung für INDEX

Turning Tool Holder

32 mm square long type
for INDEX

Porte-outil de tournage

pour 32 mm carré
Exécution longue pour INDEX

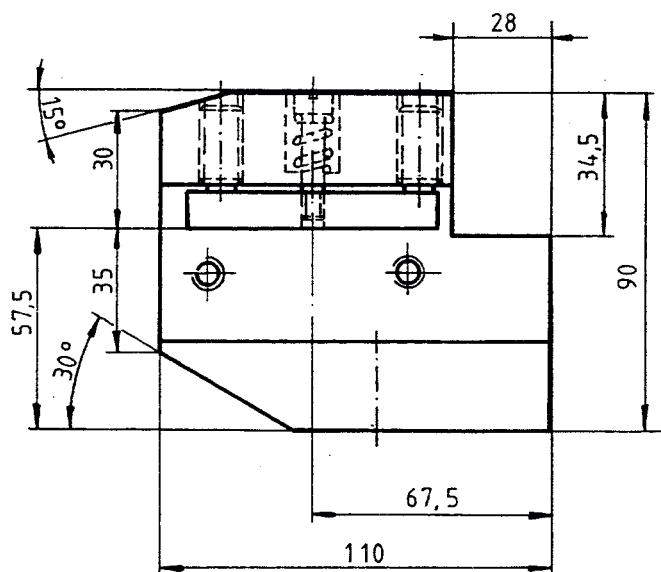
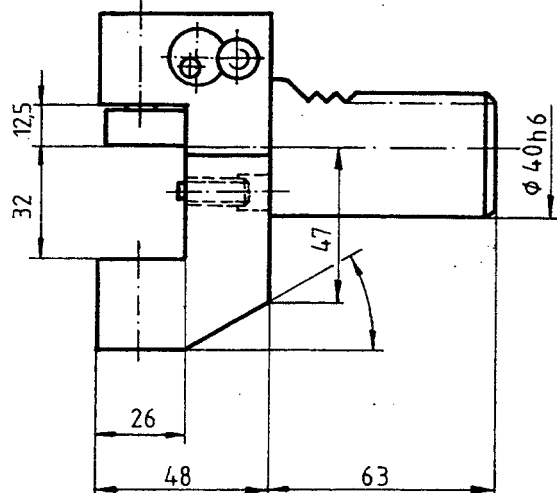

Nr. / No.

25.111

302.1300

Drehhalter

für 32 Vierkant
für INDEX

Turning Tool Holder

for 32 mm square
for INDEX

Porte-outil de tournage

pour 32 mm carré
pour INDEX

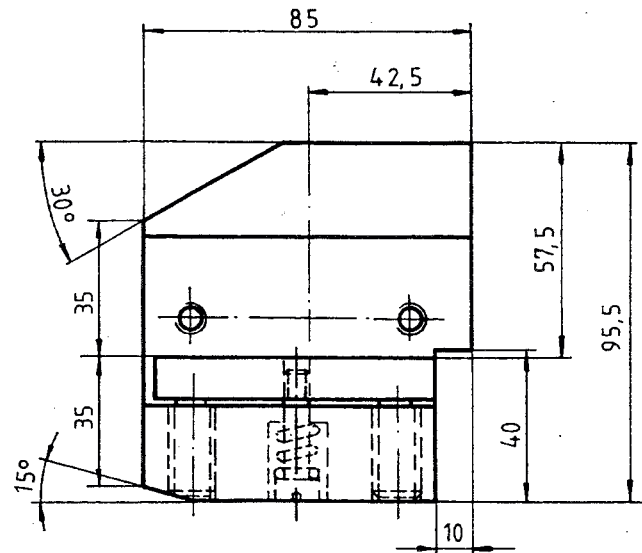
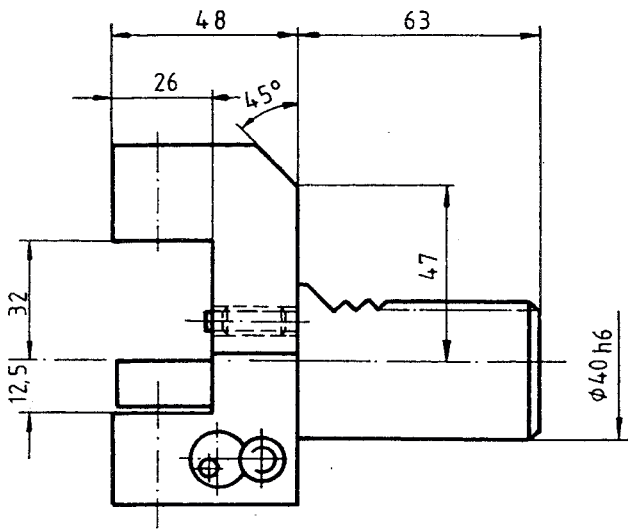

Nr. / No.
25.111
302.1500

4

Drehhalter

für INDEX

Turning Tool Holder

for INDEX

Porte-outil de tournage

pour INDEX

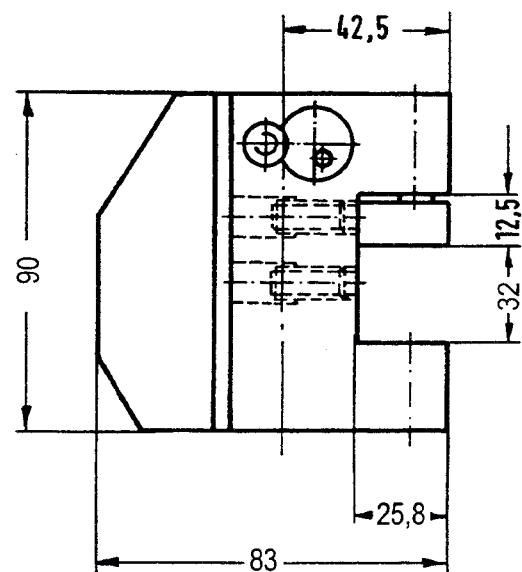
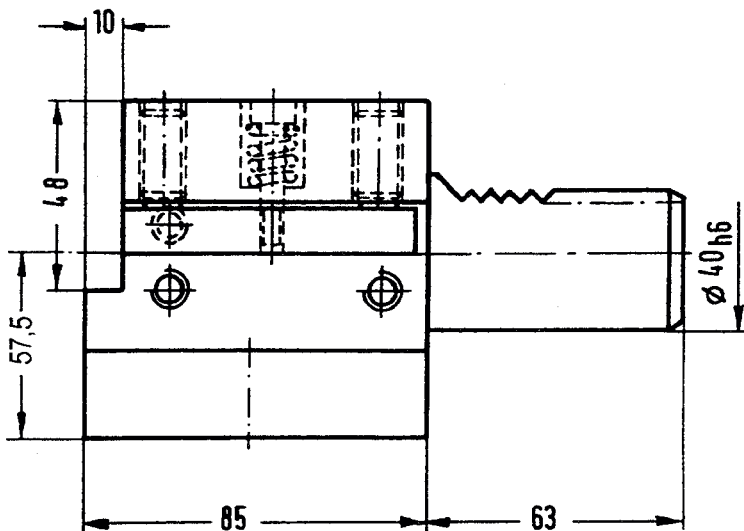

Nr. / No.
25.161
301.1700

Drehhalter

für 40 mm Schafthöhe
für INDEX

Turning Tool Holder

40 mm shaft height
for INDEX

Porte-outil de tournage

pour 40 mm hauteur tige
pour INDEX

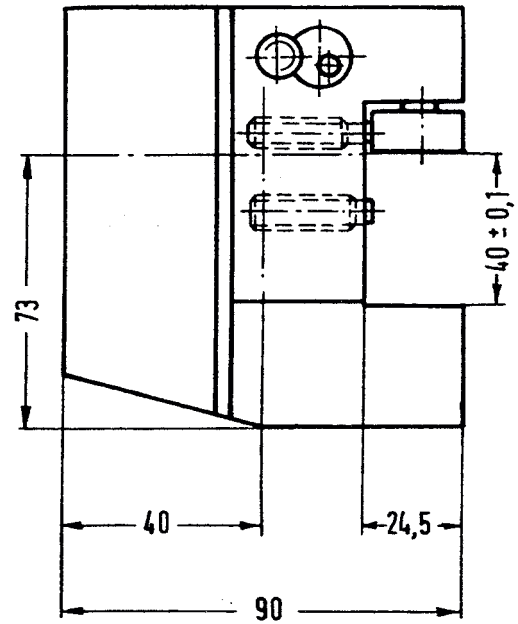
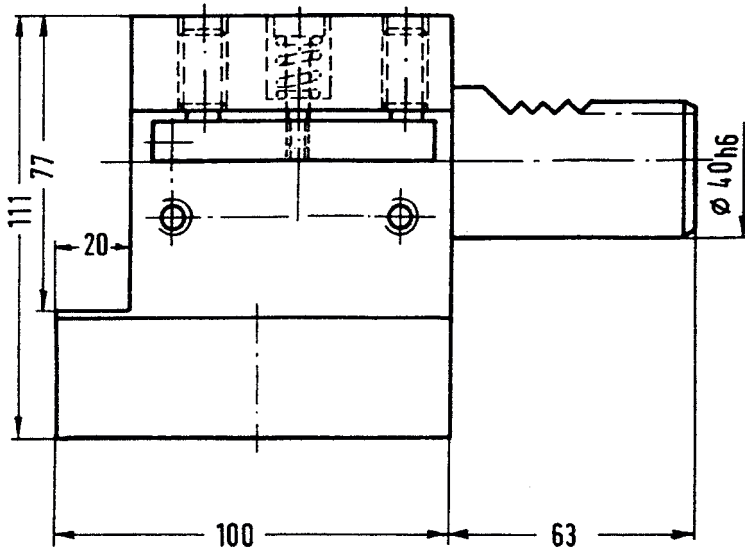

Nr. / No.

22.161

302.9300

Drehhalter

Innenbearbeitung
für INDEX

Knee Tool Holders

for internal machining
for INDEX

Porte-outil

d'usage interne
pour INDEX

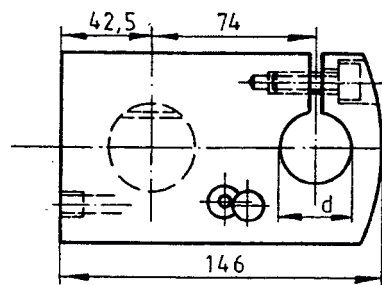
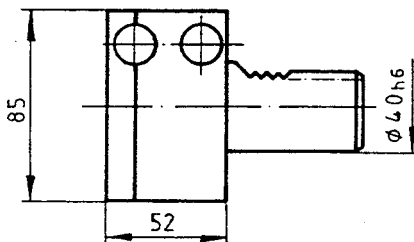

Nr. / No.

d

302.8200

25,39^{H7}

301.8300

32^{H7}

Ausdrehhalter

für INDEX

Boring Tool Holder

for INDEX

Porte-outil d'alésage

pour INDEX

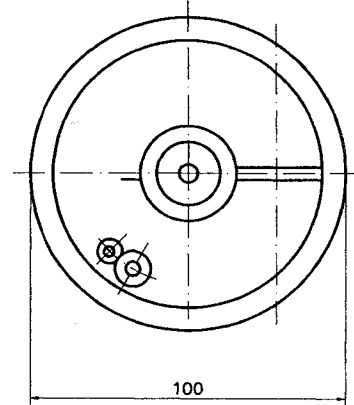
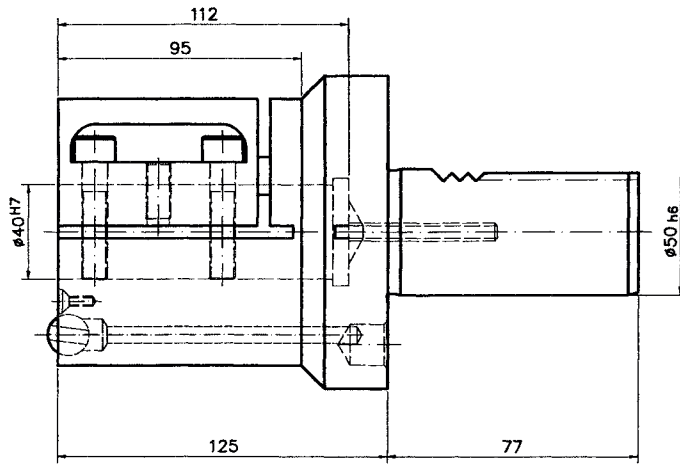

Nr. / No.
25.270
220.1600

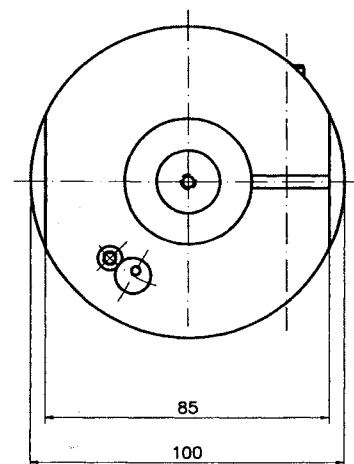
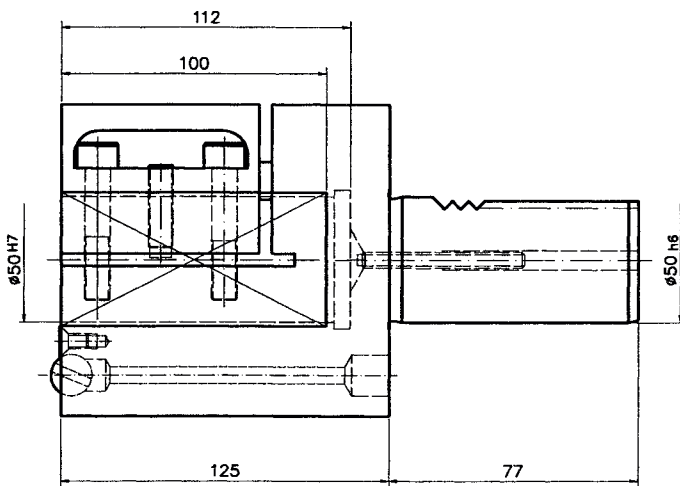

Nr. / No.
25.270
220.1700



Statische- und angetriebene Werkzeuge Schaft Ø25 für:

Static and driven tools shank Ø25 for:

Porte-outils statiques et motorisés VDI25 pour:

Index C65, C100, C200, G200, G160, V160, V200

Ausgleichhalter

für Werkzeugaufnahmen
mit Schaft nach DIN 69880
ø 20 x 40

Adaptor
for VDI 20

Adapteur
pour VDI 20

Bestell Nr
Order No.

WA2520 G200 R (V)

WA2520 G200 L (V)

WA2520 G200 RL (V)

Mit V-Leiste,
bitte hinter Bestell-Nr. angeben,
z.B. WA2520 G200 RV

With V-plate,
please add V behind the part No.
for example WA 2520 G200 RV

- Ausführung R wie gezeichnet
right hand design as shown
à droite suivant croquis
- Ausführung L spiegelbildlich
left hand design reversed
à gauche inversé
- Ausführung RL mit doppelverzahntem DIN-Schaft
(Lizenz Traub)
with doubletoothed DIN shaft
universelle pour broche et
contre-broche

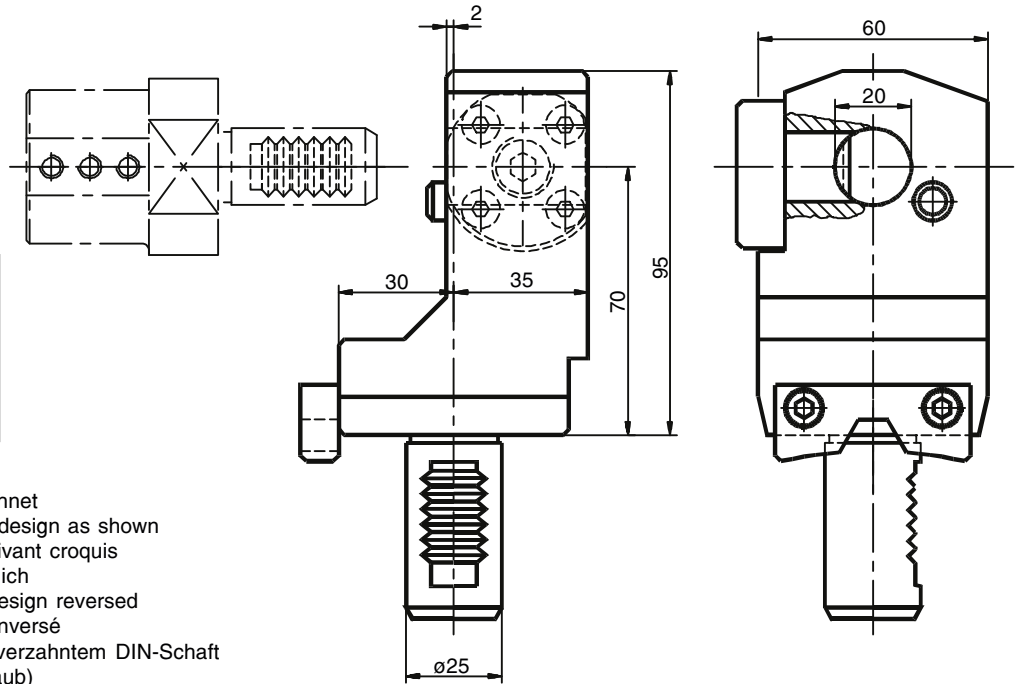

Bohrhalter

Drill Holder

Porte-foret

Mit V-Leiste,
bitte hinter Bestell-Nr. angeben,
z.B. 31.2525 G200 RV

With V-plate,
please add V behind the part No.
for example 31.2525 G200 RV

- Ausführung R wie gezeichnet
right hand design as shown
à droite suivant croquis
- Ausführung L spiegelbildlich
left hand design reversed
à gauche inversé
- Ausführung RL mit doppelverzahntem DIN-Schaft
(Lizenz Traub)
with doubletoothed DIN shaft
universelle pour broche et
contre-broche

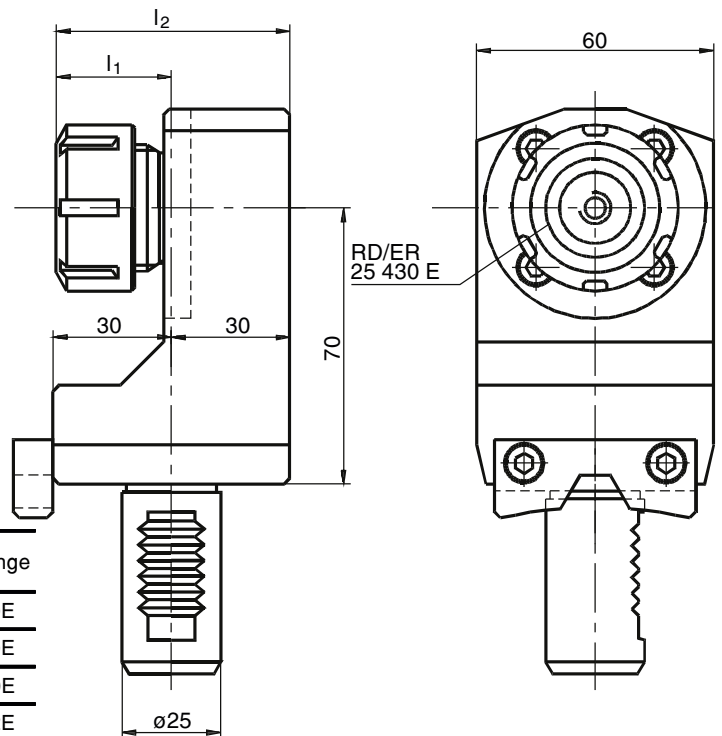

Bestell Nr Order No.	Maße d ₂ Spannbereich	l ₁	l ₂	Spannzange
31.2525 G200 R (V)	1 - 16	30	60	250 430E
31.2525 G200 L (V)	1 - 16	30	60	250 430E
31.2525 G200 RL (V)	1 - 16	30	60	250 430E
31.2540 G200 R (V)	3 - 26	55	85	400 472E
31.2540 G200 L (V)	3 - 26	55	85	400 472E
31.2540 G200 RL (V)	3 - 26	55	85	400 472E

Kombihalter

Combi holder

Porte-outil combiné

Mit V-Leiste,
bitte hinter Bestell-Nr. angeben,
z.B. 17.2525 G200 V

With V-plate,
please add V behind the part No.
for example 17.2525 G200 V

Bestell Nr Order No.	Maße d	l_1	l_2
17.2525 G200 (V)	25	70	95
17.2525K G200 (V)	25	55	80
17.2520 G200 (V)	20	70	95
17.2516 G200 (V)	16	70	95
17.2512 G200 (V)	12	70	95
17.2510 G200 (V)	10	70	95
17.2508 G200 (V)	8	70	95

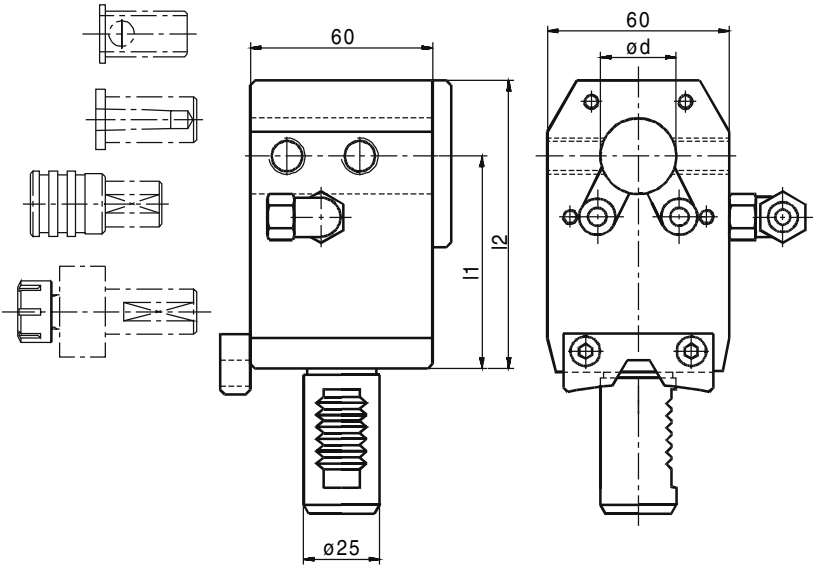

Aufnahmehülsen

Adaptor Sleeve

Douille de réduction

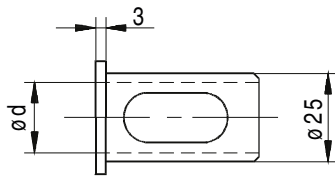

Bestell Nr Order No.	Maße ød
28.2508 S	8
28.2510 S	10
28.2512 S	12
28.2516 S	16
28.2520 S	20

Bohrer-Einsatzhülsen

Drill Insert Sleeves

Douille pour foret

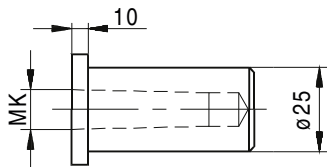

Bestell Nr Order No.	MK
QT 831	1
QT 832	2

Weiter Hülsen siehe
Katalog Rubrik 2
Further sleeves please
find in chapter 2

Gewindeschneid- Schnellwechselfutter

Thread Cutting quick-change Chuck

Porte foret pour taraud à serrage rapide

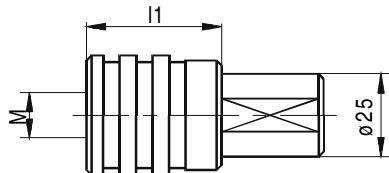

Bestell Nr Order No.	l_1	M
WFLK 1/25	41	M3 - M12
WFLK 2/25	64	M8 - M20

Pendelhalter

Floating Reamer Holder

Mandrins flottant

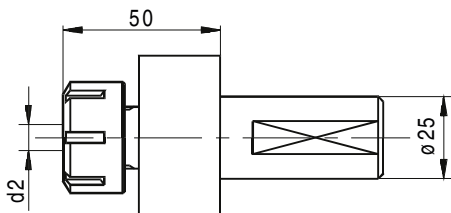

Bestell Nr Order No.	d_2	Spannzangen Collet Pince
0250025	41	RD/ER 25430E

Kombihalter und Aufnahmehülsen

Für Haupt- und Gegenspindel

Combi tool holder and Adaptor Sleeve

For main and subspindle

Porte-outil combiné et douille de réduction

Pour broche et contre-broche

Mit V-Leiste, bitte hinter Bestell-Nr. angeben, z.B. 17.2540 G200 V
With V-plate, please add V behind the part No. for example 17.2540 G200 V

Weitere ϕ auf Anfrage.
Other diameter on request.
Autre diameters sur demande.

Bestell Nr Order No.	Maße d	l_1	l_2
17.2540 G200 (V)	40	70	95
17.2532 G200 (V)	32	70	95
17.2532K G200 (V)	32	55	80
17.2532 ABC (V)	32	60	85
17.2532L G200 (V)	32	80	105

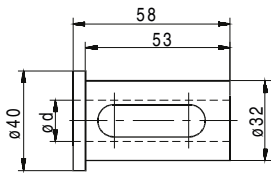

Bestell Nr Order No.	d
28.3206 G200	06
28.3208 G200	08
28.3210 G200	10
28.3212 G200	12
28.3216 G200	16
28.3220 G200	20
28.3225 G200	25
28.3225.4 G200	25,4 (1")

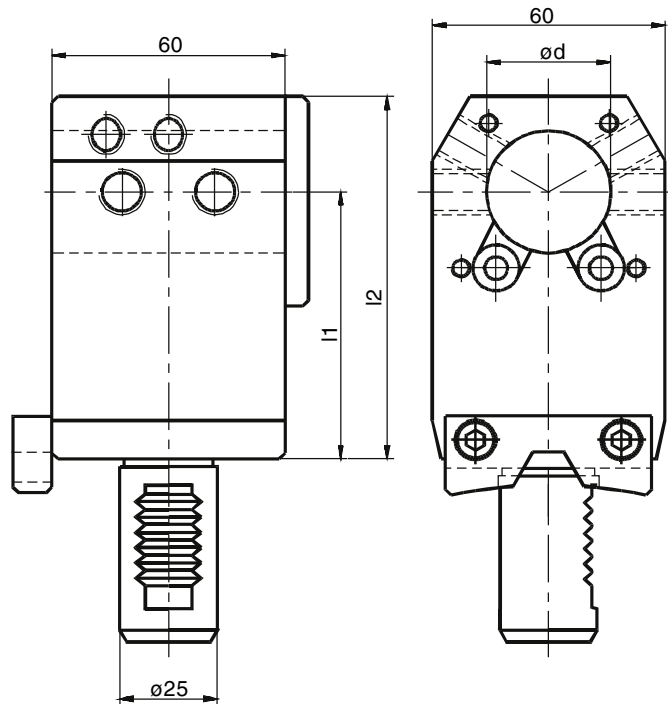

Ausdrehalter

Boring Tool Holder

Porte-outil d'alésage

Mit V-Leiste, bitte hinter Bestell-Nr. angeben, z.B. 27.2525 G200 RV
With V-plate, please add V behind the part No. for example 27.2525 G200 LV

Bestell Nr Order No.
27.2525 G200 R (V)
27.2525 G200 L (V)
27.2525 G200 RL (V)

Ausführung	R	wie gezeichnet right hand design as shown à droite suivant croquis
Ausführung	L	spiegelbildlich left hand design reversed à gauche inversé
Ausführung	RL	mit doppelverzahntem DIN-Schaft (Lizenz Traub) with doubletoothed DIN shaft universelle pour broche et contre-broche

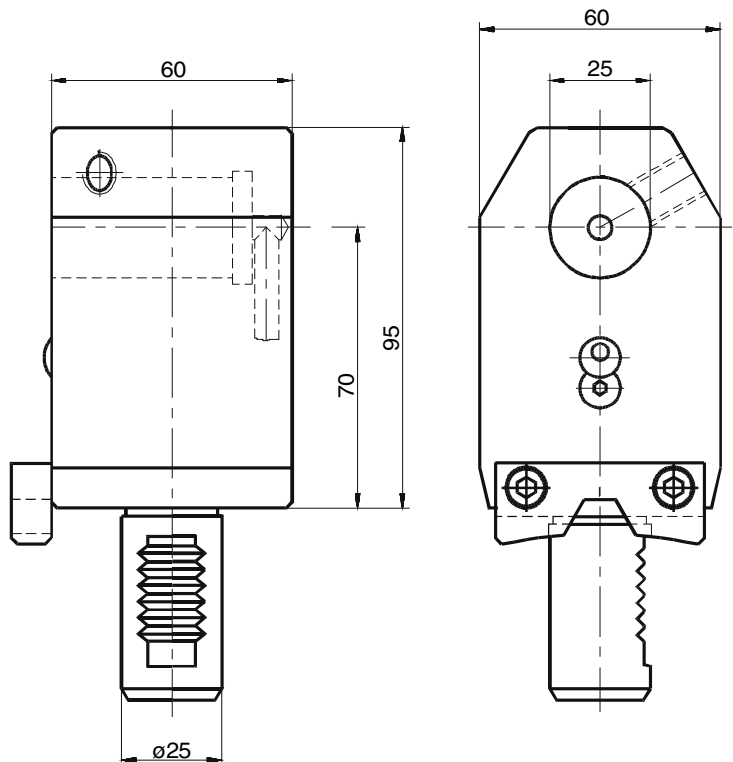

Ausdrehalter mit Höhenverstellung

Boring Tool Holder with height adjustment

Porte-outil d'alésage avec hauteur réglable

Mit V-Leiste, bitte hinter Bestell-Nr. angeben, z.B. 220.1000 G200 RV
 With V-plate, please add V behind the part No. for example 220.1000 G200 RV

Bestell Nr Order No.
220.1000 G200 R (V)
220.1000 G200 L (V)
220.1000 G200 RL (V)

- Ausführung R wie gezeichnet
right hand design as shown
à droite suivant croquis
- Ausführung L mit Spiegelbildlich
left hand design reversed
à gauche inversé
- Ausführung RL mit doppelverzahntem DIN-Schaft
(Lizenz Traub)
with doubletoothed DIN shaft
universelle pour broche et contre-broche

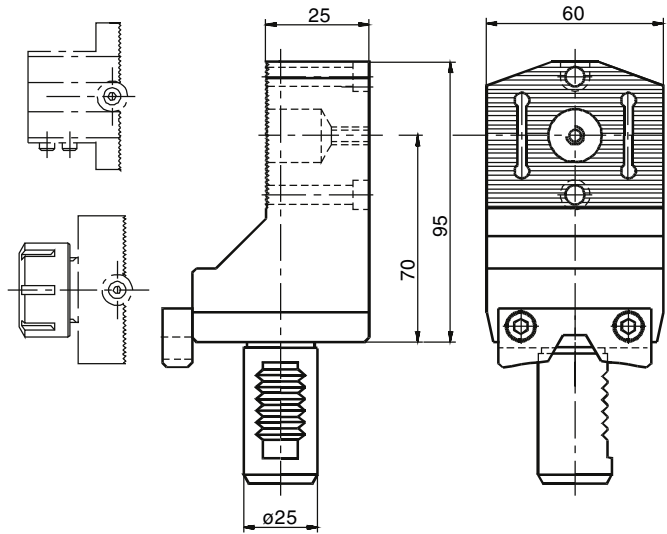

Ausdrehaltestück

Boring Tool Block

Support d'alésage

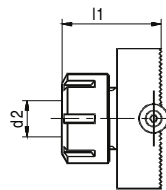

Bestell Nr Order No.	Maße d ₂ Spannbereich capacity / capacité	l ₁	Spannzange Collet / Pince
20.650	0,5 - 10	36	160 426E
220.1010			
20.650	1 - 16	41	250 430E
220.1020			

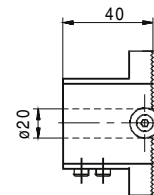

Bestell Nr Order No.
20.650
220.1030

Werkstoffanschlag verstellbar Stock Stop Porte-outil à buté de longueur

Abstechhalter höhenverstellbar Parting off holder Porte-outil de plongée

Bestell Nr Order No.
25.500 G200 RL

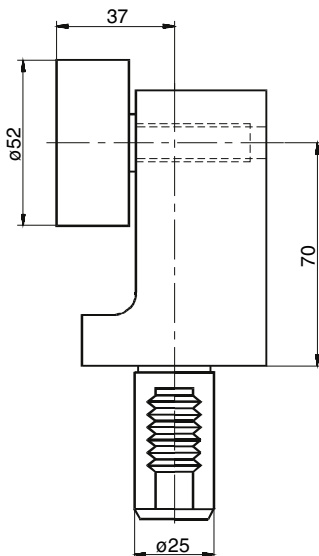

Bestell Nr Order No.	SH
32.2526 G200 RL	26
32.2526 G200 RL ÜK	26
32.2532 G200 RL	32
32.2532 G200 RL ÜK	32

- RL wie gezeichnet
right hand design as shown
à droite suivant croquis
- RL ÜK spiegelbildlich
left hand design reversed
à gauche inversé

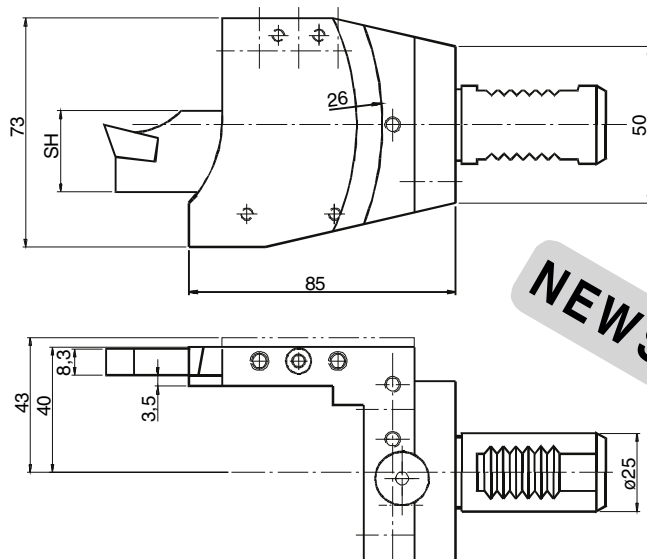

NEWS

Stechhalter mit Höheneinstellung

Infeed Tool Holder with height adjustment

Porte-outil de plongée à réglage vertical de centrage

Mit V-Leiste, bitte hinter Bestell-Nr. angeben, z.B. 310.0800 G200 RV
 With V-plate, please add V behind the part No. for example 310.0800 G200 RV

Bestell Nr Order No.
310.0800 G200 R (V)
310.0900 G200 L (V)
310. G200 RL (V)

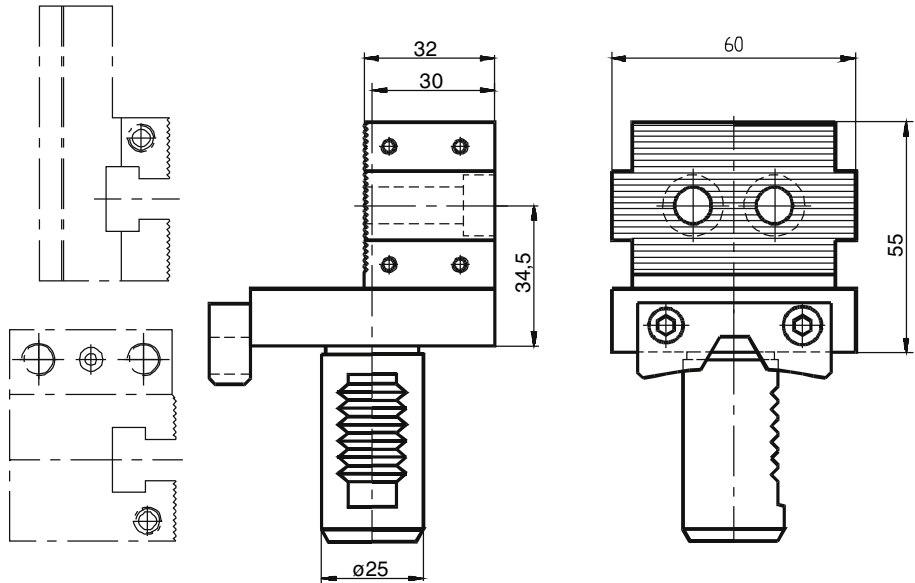

R wie gezeichnet
right hand design as shown
à droite suivant croquis

L spiegelbildlich
left hand design reversed
à gauche inversé

RL mit doppelverzahntem DIN-Schaft (Lizenz Traub)
with doubletoothed DIN shaft
universelle pour broche et contre-broche

Stechhaltestück

Infeed Tool Block

Support outil de plongée

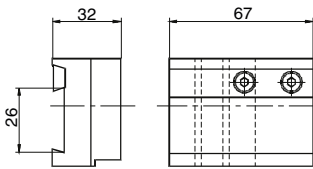

Bestell Nr Order No.	h_1
300.0980 R*	26
300.0981 R*	32
300.0980 L*	26
300.0981 L*	32

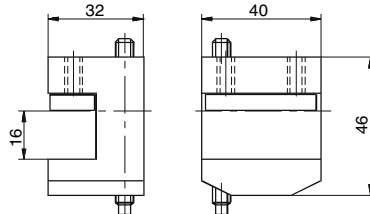

Bestell Nr Order No.
25.701
1661.10

*L wie gezeichnet / left hand design as shown / à gauche suivant croquis
 *R spiegelbildlich / right hand design reversed / à droite inversé

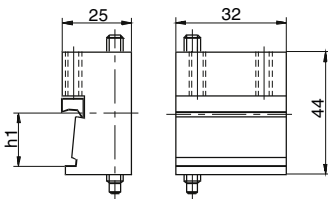

Bestell Nr Order No.	h_1
25.704	16
1661.40	
25.705	20
1661.70	

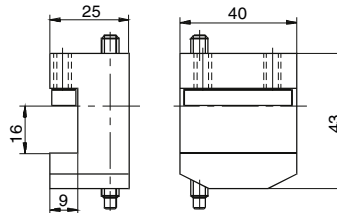

Bestell Nr Order No.
25.703
1661.30

Strehlhaltestück

Chaser Block

Support outil à fileter

Bestell Nr Order No.
230.0010

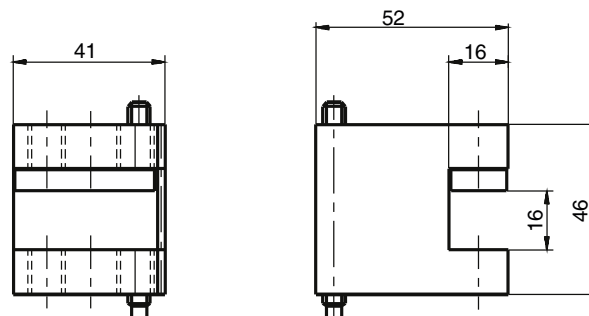

Drehhalter

Turning Tool holder

Porte-outil de tournage

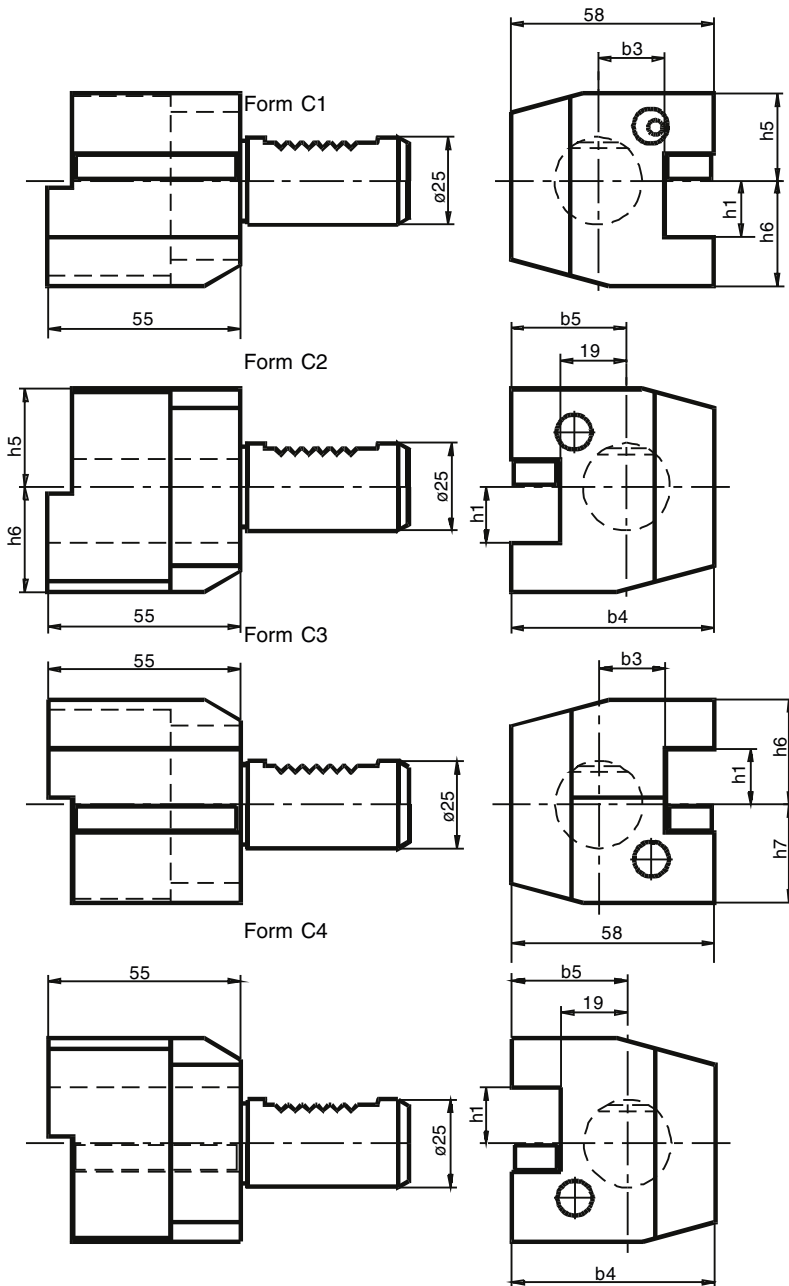

Bestell Nr Order No.	h_1	h_5	h_6	h_7	b_3	b_4	b_5
Form C1							
1.2516	16	25	30	--	19	--	--
1.2520	20	28	38	--	15	--	--
Form C2							
4.2516	16	25	30	--	--	58	33
4.2520	20	28	38	--	--	62	37
Form C3							
2.2516	16	--	30	25	19	--	--
2.2520	20	--	38	28	15	--	--
Form C4							
3.2516	16	--	30	25	--	58	33
3.2520	20	--	38	28	--	62	37

Auch mit Doppelverzahnung lieferbar.
Also as RL-version available.

Doppel-Drehhalter

Double turning toolholder

Porte-outil double-coté

Bestell Nr
Order No.
15.2520 G200

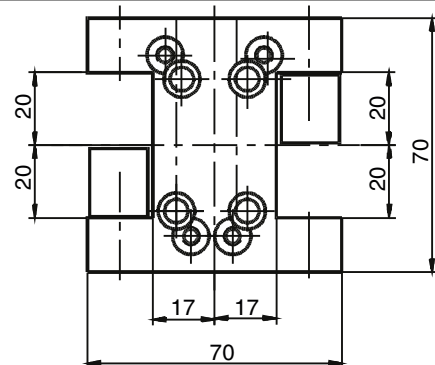
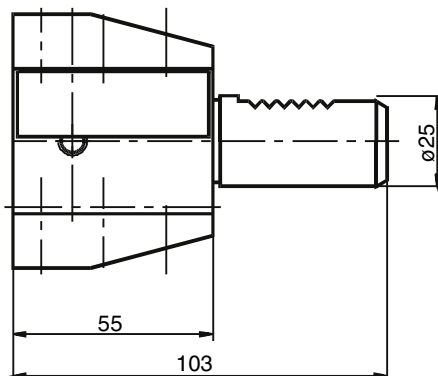

Vierkant Queraufnahme

Turning tool radial

Radial porte-outil carré

Bestell Nr Order No.	
5.2520 G200	wie gezeichnet right hand design as shown à droite suivant croquis
6.2520 G200	spiegelbildlich left hand design reversed à gauche inversé
5.2520 G200 RL	mit doppelverzahntem DIN - Schaft with doubletoothed DIN shaft universelle pour broche et contre-broche

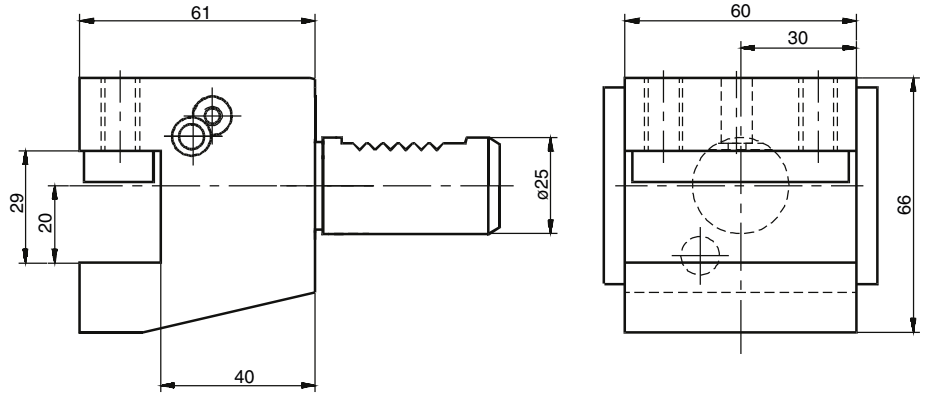

Bohrhalter für Werkzeuge nach DIN 1835 E

Drillholder for tools to suit DIN 1835 E

Porte barre d'alésage pour outils DIN 1835 E

Mit V-Leiste,
bitte hinter Bestell-Nr. angeben,
z.B. 27.2506 G2WN RV
With V-plate,
please add V behind the part No.
for example 27.2506 G2WN RV

Bestell Nr Order No.	d ₁	l ₁
27.2506 WN G200 RL	6	36
27.2508 WN G200 RL	8	36
27.2510 WN G200 RL	10	40
27.2512 WN G200 RL	12	45
27.2514 WN G200 RL	14	45
27.2516 WN G200 RL	16	48
27.2518 WN G200 RL	18	48
27.2520 WN G200 RL	20	50
27.2525 WN G200 RL	25	54

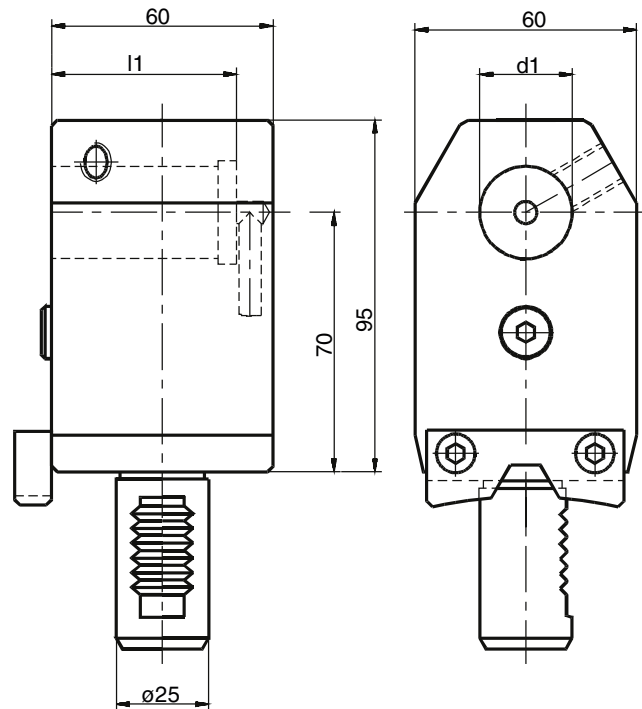

Ausführung RL mit doppelverzahntem DIN-Schaft
(Lizenz Traub)
with doubletoothed DIN shaft
universelle pour broche et
contre-broche



Axial Bohr- und Fräskopf

Axial drilling and milling head

Tête de perçage et fraisage

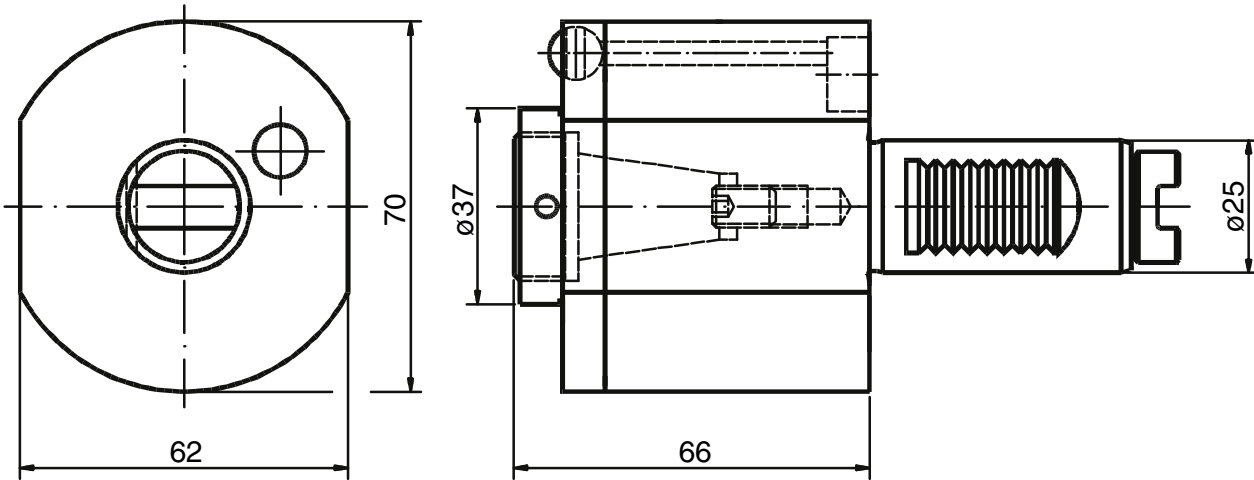

Bestell Nr Order No.	i	n _{max} [1/min]	T _{max} [Nm]	Schlüsselsatz Wrench-set	Spannzange (siehe 1.27) Collet (see 1.27)
40.2520 G200	1:1	6000	16	LS20/HS40	RD/ER 20 428E (1-13)

Innere Kühlmittelzufuhr:
Zusatz IK an Bestellnummer anfügen.
Central cooling supply:
Please add IK behind order no.

Axial Bohr- und Fräskopf

Axial drilling and milling head

Tête de perçage et fraisage

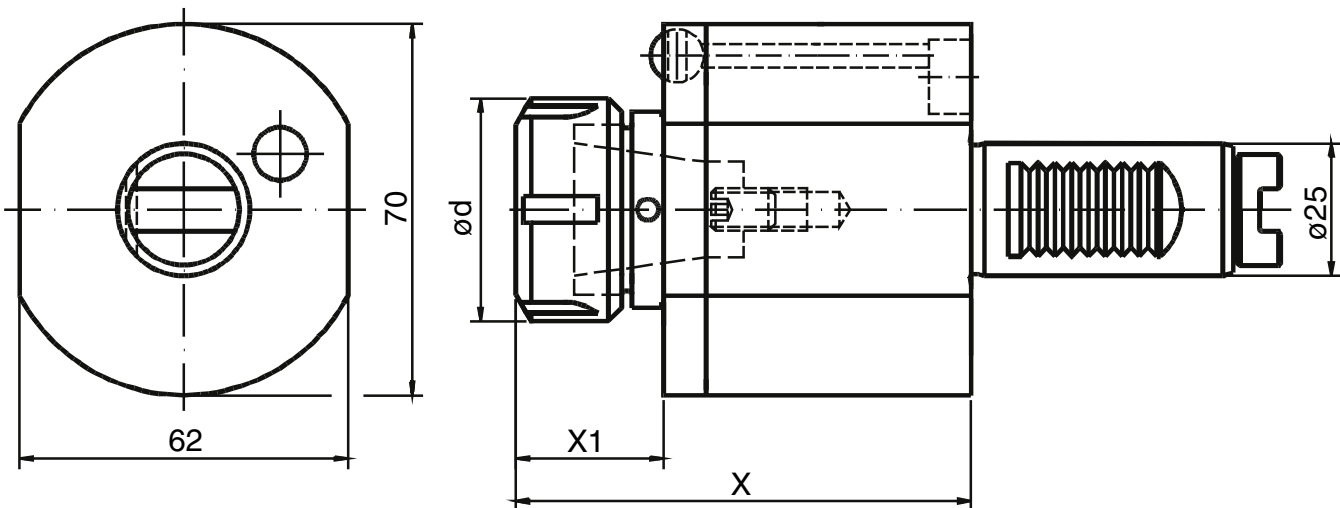

Innere Kühlmittelzufuhr:
Zusatz IK an Bestellnummer anfügen.
Central cooling supply:
Please add IK behind order no.

Bestell Nr Order No.	i	X	X ₁	$\varnothing d$	n _{max} [1/min]	T _{max} [Nm]	Schlüsselsatz Wrench-set	Spannzange (siehe 1.27) Collet (see 1.27)
40.2520 G200 AM	1:1	78	--	35	6000	16	GS30/HS40	RD/ER 20 428E (1-13)
40.2525 G200	1:1	79	27	42	6000	16	225/HS40	RD/ER 20 430E (2-16)

Axial Bohr- und Fräskopf

Axial drilling and milling head

Tête de perçage et fraisage

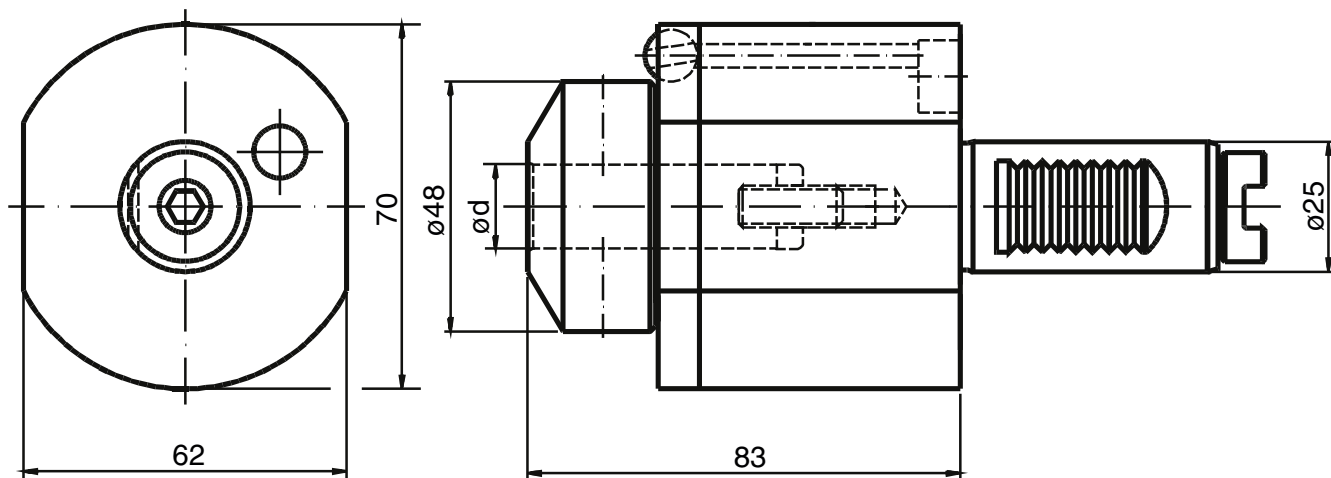

Bestell Nr Order No.	i	ød	n _{max} [1/min]	T _{max} [Nm]
40.2516 WN G200	1:1	16	6000	16
40.2512 WN G200	1:1	12	6000	16
40.2510 WN G200	1:1	10	6000	16

Innere Kühlmittelzufuhr:
Zusatz IK an Bestellnummer anfügen.
Central cooling supply:
Please add IK behind order no.

Axial Bohr- und Fräskopf

Axial drilling and milling head

Tête de perçage et fraisage

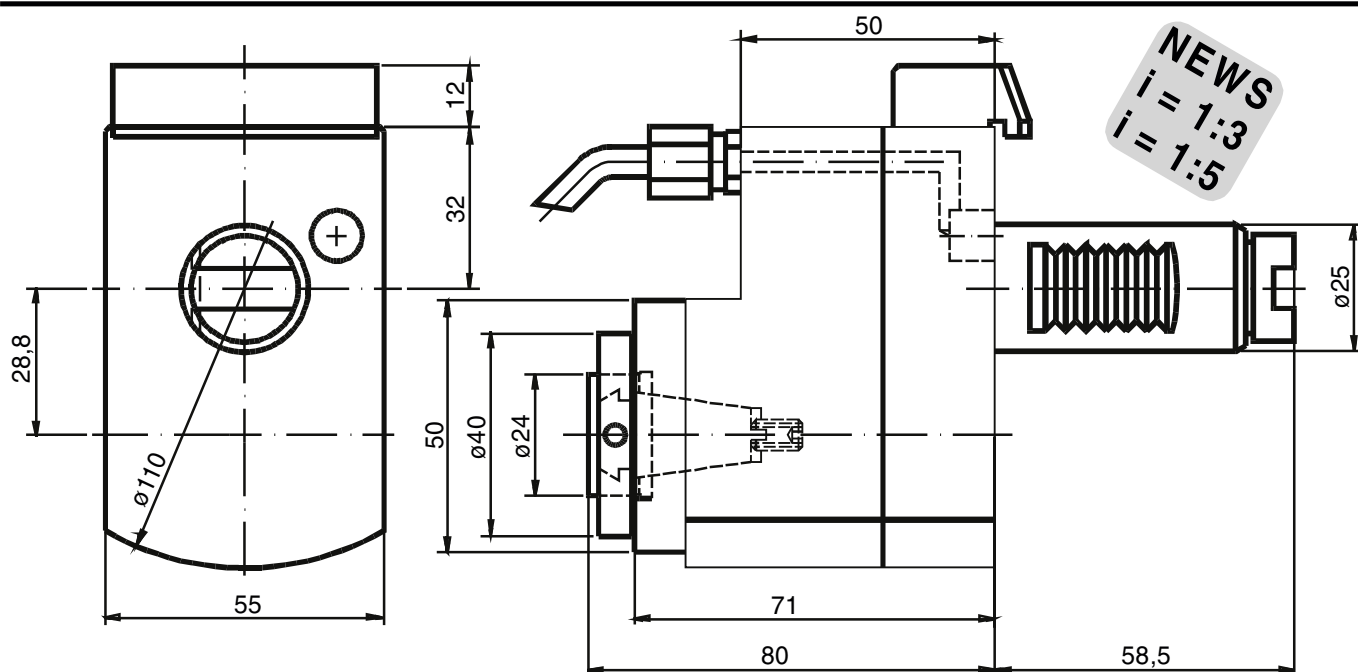

Bestell Nr Order No.	i	n _{max} [1/min]	T _{max} [Nm]	Schlüsselsatz Wrench-set	Spannzange (siehe 1.27) Collet (see 1.27)
50.2516 G200/1	1:2	12000	8	LS16/HS40	RD/ER 16 426E (1-10)
40.2516 G200/13	1:3	15000	6	Maße auf Anfrage Dim. on request	RD/ER 16 426E (1-10)
40.2516 G200/15	1:5	25000	4		RD/ER 16 426E (1-10)

Innere Kühlmittelzufuhr:
Zusatz IK an Bestellnummer anfügen.
Central cooling supply:
Please add IK behind order no.

Axial Gewindebohrkopf

Axial tapping head

Tête de taraudage

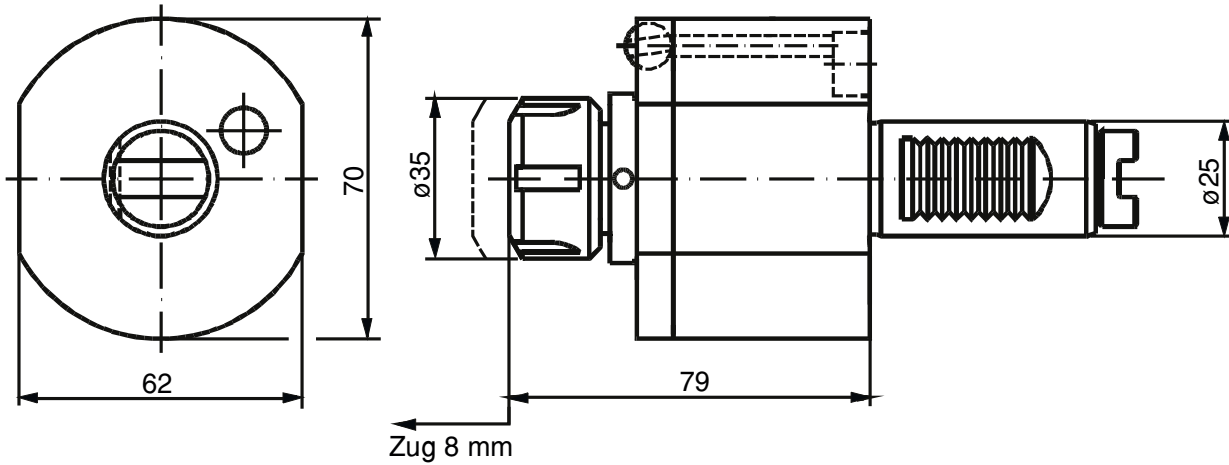

Bestell Nr Order No.	i	n_{max} [1/min]	T_{max} [Nm]	Schlüsselsatz Wrench-set	Spannzange (siehe 1.27) Collet (see 1.27)
41.2520 G200	1:1	6000	16	GS30/GS22	RD/ER 20 428 E (1-13)

Radial Bohr- und Fräskopf

Radial drilling and milling head

Tête de perçage et fraisage radial

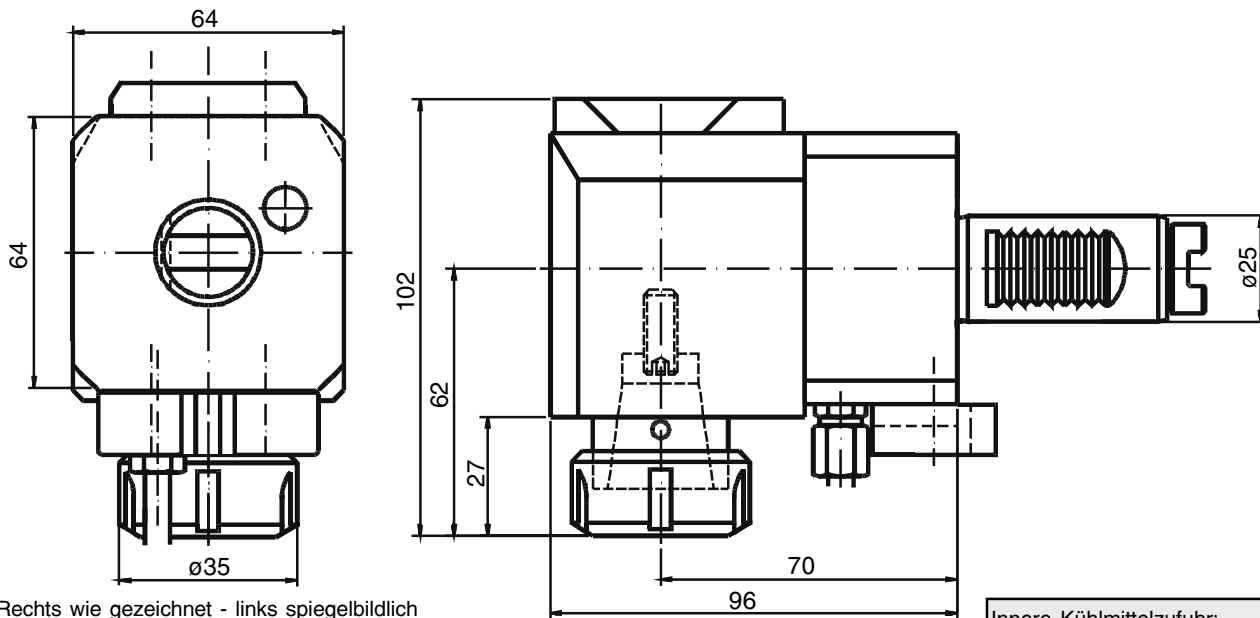

Rechts wie gezeichnet - links spiegelbildlich
Bitte bei linker Ausführung L angeben.

Right hand as shown - left hand reversed
add L behind order No.

Innere Kühlmittelzufuhr:
Zusatz IK an Bestellnummer anfügen.
Central cooling supply:
Please add IK behind order no.

Bestell Nr Order No.	i	n_{max} [1/min]	T_{max} [Nm]	Schlüsselsatz Wrench-set	Spannzange (siehe 1.27) Collet (see 1.27)
60.2520 G200 (V)	1:1	6000	16	GS30/HS40	RD/ER 20 428 E (1-13)
60.2520 G200/1 (V)	1:2	12000	16	GS30/HS40	RD/ER 20 428 E (1-13)
60.2520 G200/2 (V)	2:1	6000	32	GS30/HS40	RD/ER 20 428 E (1-13)
60.2516 G200/15 (V)	1:5	20000	5	Maße auf Anfrage	

Mit V-Leiste,
bitte hinter Bestell-Nr. angeben,
z.B. 60.2520 G200 V

With V-plate,
please add V behind the part No.
for example 60.2520 G200 V

Radial Bohr- und Fräskopf

Radial drilling and milling head

Tête de perçage et fraisage radial

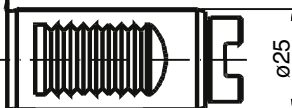
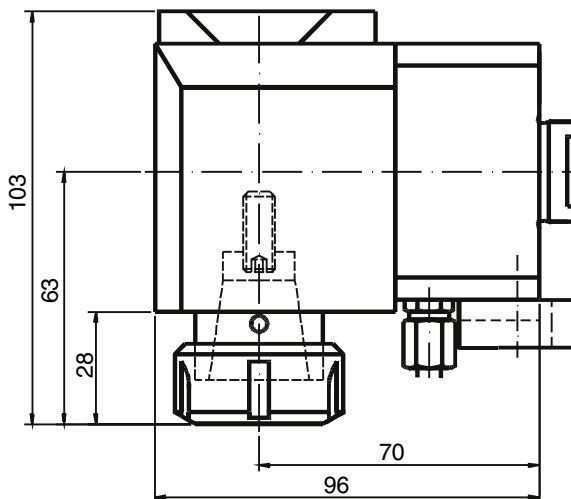
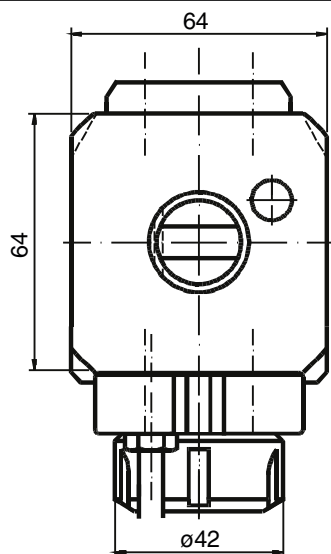

Rechts wie gezeichnet - links spiegelbildlich
 Bitte bei linker Ausführung L angeben.

Right hand as shown - left hand reversed
 add L behind order No.

Innere Kühlmittelzufuhr:
 Zusatz IK an Bestellnummer anfügen.
 Central cooling supply:
 Please add IK behind order no.

Mit V-Leiste,
 bitte hinter Bestell-Nr. angeben,
 z.B. 60.2525 G200 V
 With V-plate,
 please add V behind the part No.
 for example 60.2525 G200 V

Bestell Nr Order No.	i	n_{max} [1/min]	T_{max} [Nm]	Schlüsselsatz Wrench-set	Spannzange (siehe 1.27) Collet (see 1.27)
60.2525 G200 (V)	1:1	6000	16	225/HS40	RD/ER 25 430 E (2-16)
60.2525 G200/2 (V)	2:1	6000	32	225/HS40	RD/ER 25 430 E (2-16)

Radial Bohr- und Fräskopf

Radial drilling and milling head

Tête de perçage et fraisage radial

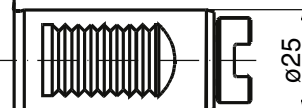
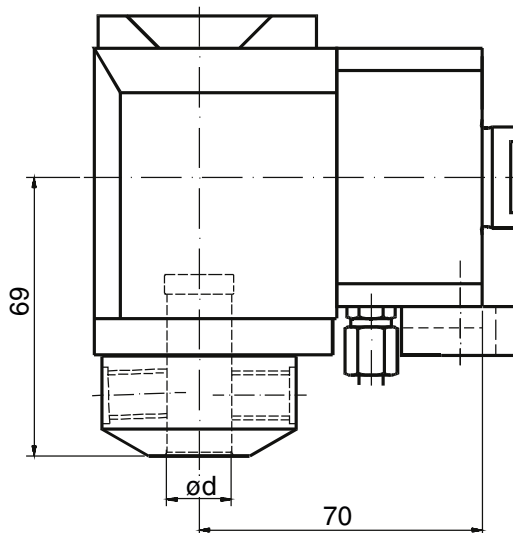
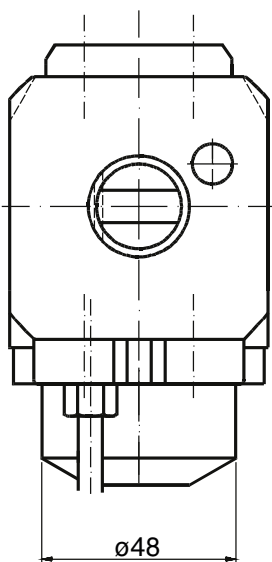

Rechts wie gezeichnet - links spiegelbildlich
 Bitte bei linker Ausführung L angeben.

Right hand as shown - left hand reversed
 add L behind order No.

Innere Kühlmittelzufuhr:
 Zusatz IK an Bestellnummer anfügen.
 Central cooling supply:
 Please add IK behind order no.

Mit V-Leiste,
 bitte hinter Bestell-Nr. angeben,
 z.B. 60.2520 G200 V

With V-plate,
 please add V behind the part No.
 for example 60.2520 G200 V

Bestell Nr Order No.	i	d	n_{max} [1/min]	T_{max} [Nm]
60.2508 WN G200 (V)	1:1	8	6000	16
60.2510 WN G200 (V)	1:1	10	6000	16
60.2512 WN G200 (V)	1:1	12	6000	16
60.2514 WN G200 (V)	1:1	14	6000	16
60.2516 WN G200 (V)	1:1	16	6000	16
60.2516 WN G200/2 (V)	1:2	16	6000	32
60.2520 WN G200 (V)	1:1	20	6000	16

Radial Gewindebohrkopf

Radial tapping head

Tête de taraudage radial

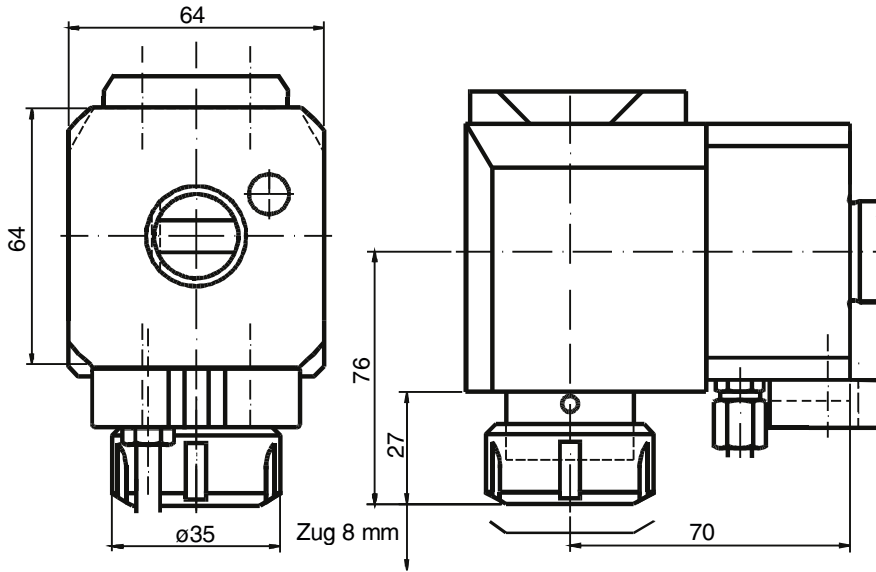

Rechts wie gezeichnet - links spiegelbildlich
 Bitte bei linker Ausführung L angeben.
 Doppelverzahnung RL (Patent Traub)

Right hand as shown - left hand reversed
 add L behind order No.
 Double serration RL (licence Traub)

Innere Kühlmittelzufuhr:
 Zusatz IK an Bestellnummer anfügen.
 Central cooling supply:
 Please add IK behind order no.

Mit V-Leiste,
 bitte hinter Bestell-Nr. angeben,
 z.B. 61.2520 G200 V

With V-plate,
 please add V behind the part No.
 for example 61.2520 G200 V

Bestell Nr Order No.	i	n_{max} [1/min]	T_{max} [Nm]	Schlüsselsatz Wrench-set	Spannzange (siehe 1.27) Collet (see 1.27)
61.2520 G200 (V)	1:1	6000	16	GS30/GS22	RD/ER 20 428 E (1-13)

Radial Bohr- und Fräskopf

Radial drilling and milling head

Tête de perçage et fraiseage radial

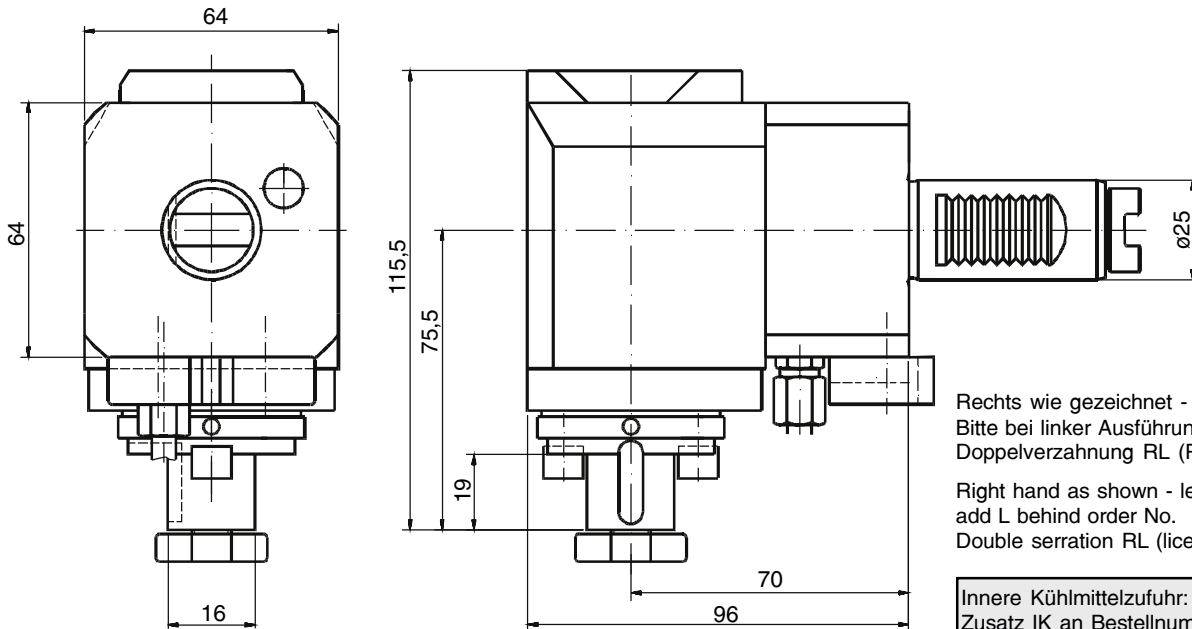

Rechts wie gezeichnet - links spiegelbildlich
 Bitte bei linker Ausführung L angeben.
 Doppelverzahnung RL (Patent Traub)

Right hand as shown - left hand reversed
 add L behind order No.
 Double serration RL (licence Traub)

Innere Kühlmittelzufuhr:
 Zusatz IK an Bestellnummer anfügen.
 Central cooling supply:
 Please add IK behind order no.

Mit V-Leiste,
 bitte hinter Bestell-Nr. angeben,
 z.B. 60.2525 G200 V

With V-plate,
 please add V behind the part No.
 for example 60.2525 G200 V

Bestell Nr Order No.	i	n_{max} [1/min]	T_{max} [Nm]	Andere ϕ verfügbar Other ϕ available Autre ϕ possible
62.2516 G200 (V)	1:1	6000	25	
62.2516 G200/2 (V)	2:1	3000	40	
62.2522 G200 (V)	1:1	6000	25	
62.2522 G200/2 (V)	2:1	3000	40	

Axial Fräskopf

Axial milling head

Tête de fraisage

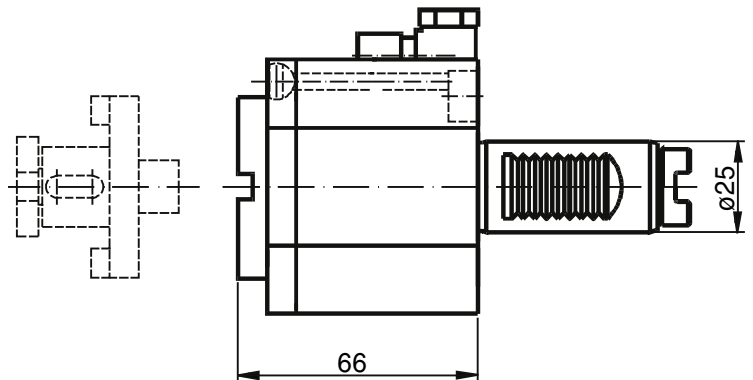
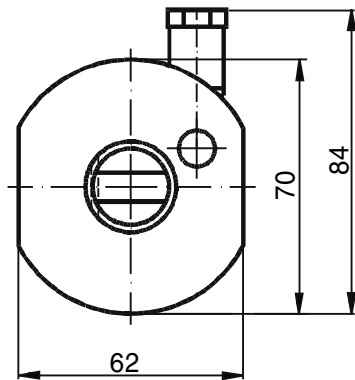

Bestell Nr Order No.	i	n_{\max} [1/min]	T_{\max} [Nm]
42.2500 G200	1:1	5000	25

Schwenkkopf $\pm 105^\circ$

Swivel head $\pm 105^\circ$

Tête pivotante $\pm 105^\circ$

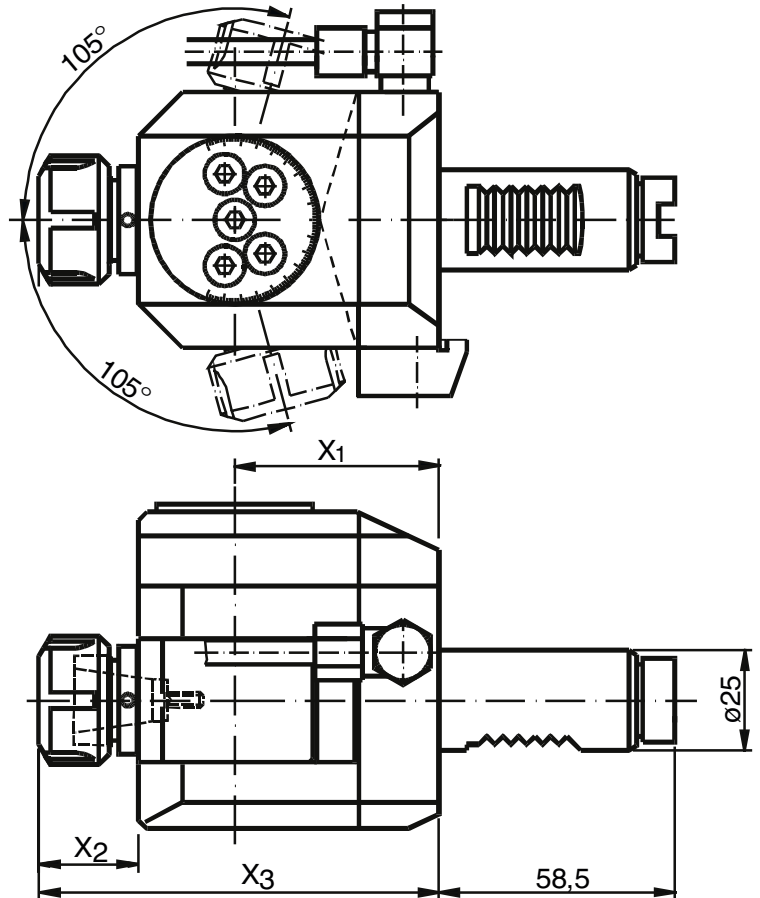
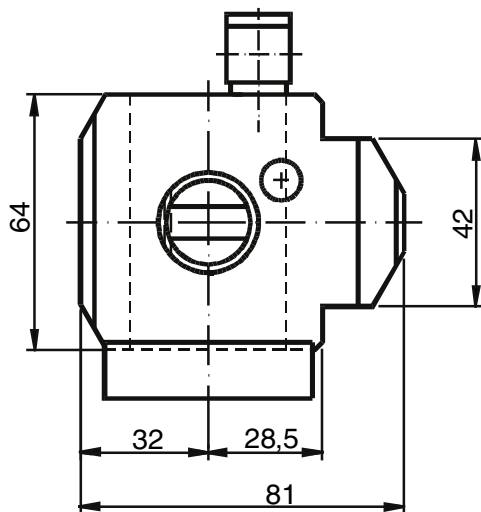

NEWS
i = 1:2

Bestell Nr Order No.	i	d	X ₁	X ₂	X ₃	n_{\max} [1/min]	T_{\max} [Nm]	Schlüsselsatz Wrench-set	Spannzange (siehe 1.27) Collet (see 1.27)
63.2516 G200/1(V)	1:2	32	53	25	102	10000	18	GS25/HS25	RD/ER 16 426 E (1-10)
63.2520 G200 (V)	1:1	35	58	26	115	10000	16	GS30/HS35	RD/ER 20 428 E (1-13)

Radial Scheibenfräserkopf

Radial drilling head for side milling cutters

Tête de fraisage radial pour fraise scie

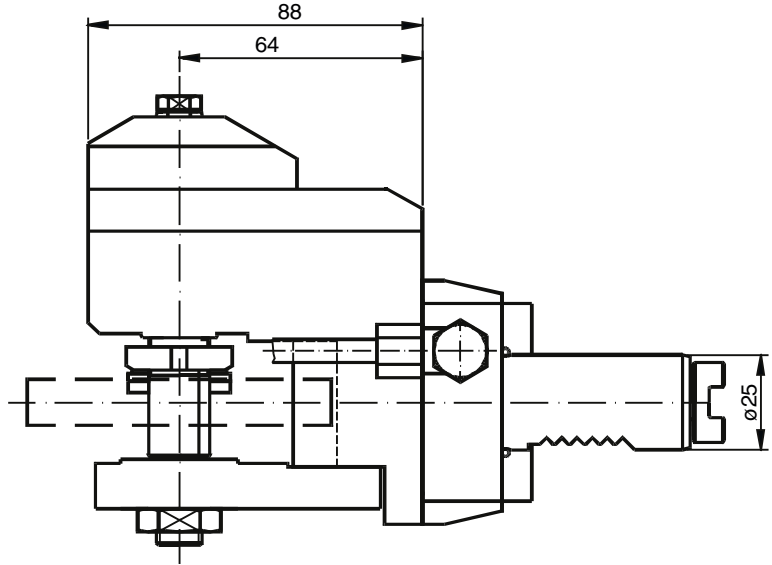
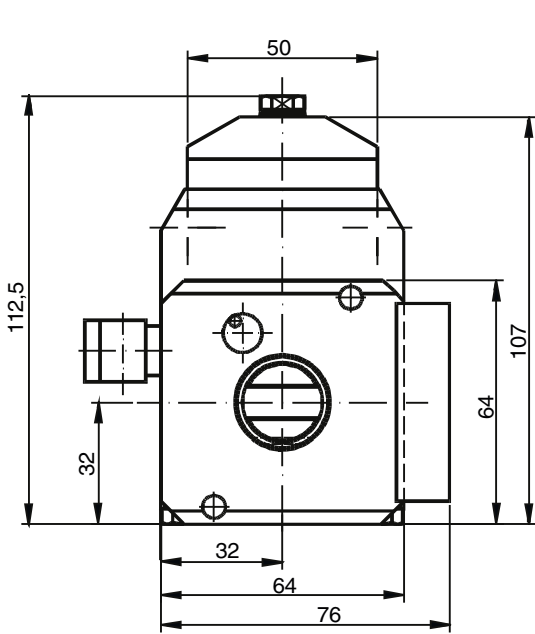

Bestell Nr Order No.	i	n_{max} [1/min]	T_{max} [Nm]	Fräswelle ød Milling arbor ød Mandrins de fraise ød
64.25(d) G200	3:1	2000	40	10 / 13 / 16 / 22

Fräserwelle ø bei Bestellung angeben.
Milling arbor ø please inform of order.
Beispiel / Example: 64.2516 G200

Querfräskopf

Angle milling head

Tête de fraisage angulaire

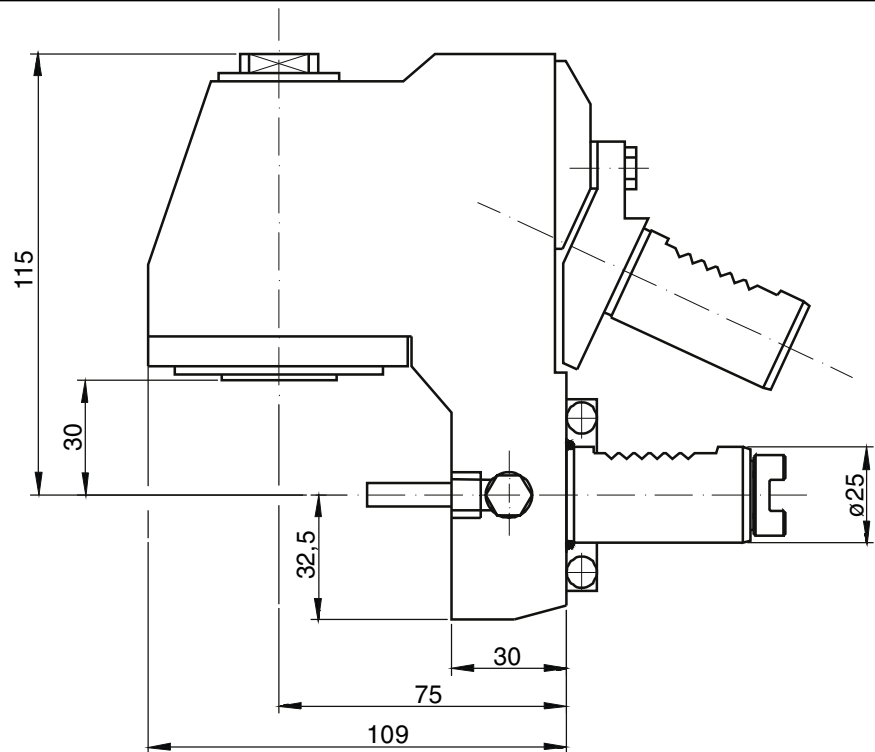
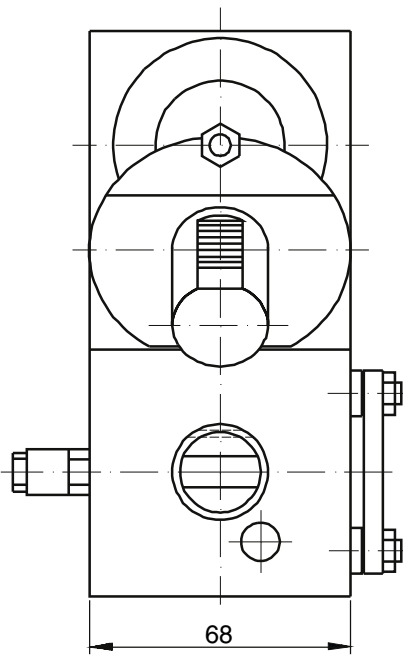

Bestell Nr Order No.	i	n_{max} [1/min]	T_{max} [Nm]	Schlüsselsatz Wrench-set	Spannzange (siehe 1.27) Collet (see 1.27)	WN
65.2520 G200	2:1	4000	32	LS20	RD/ER 20 426 E (1-13)	
65.2516 WN G200	2:1	4000	32	LS20	WN 16	

Axial Bohr- und Fräskopf
y-verstellbar

Axial drilling and milling head
y-axis adjustable

Tête de perçage et fraisage
reglable y-axis

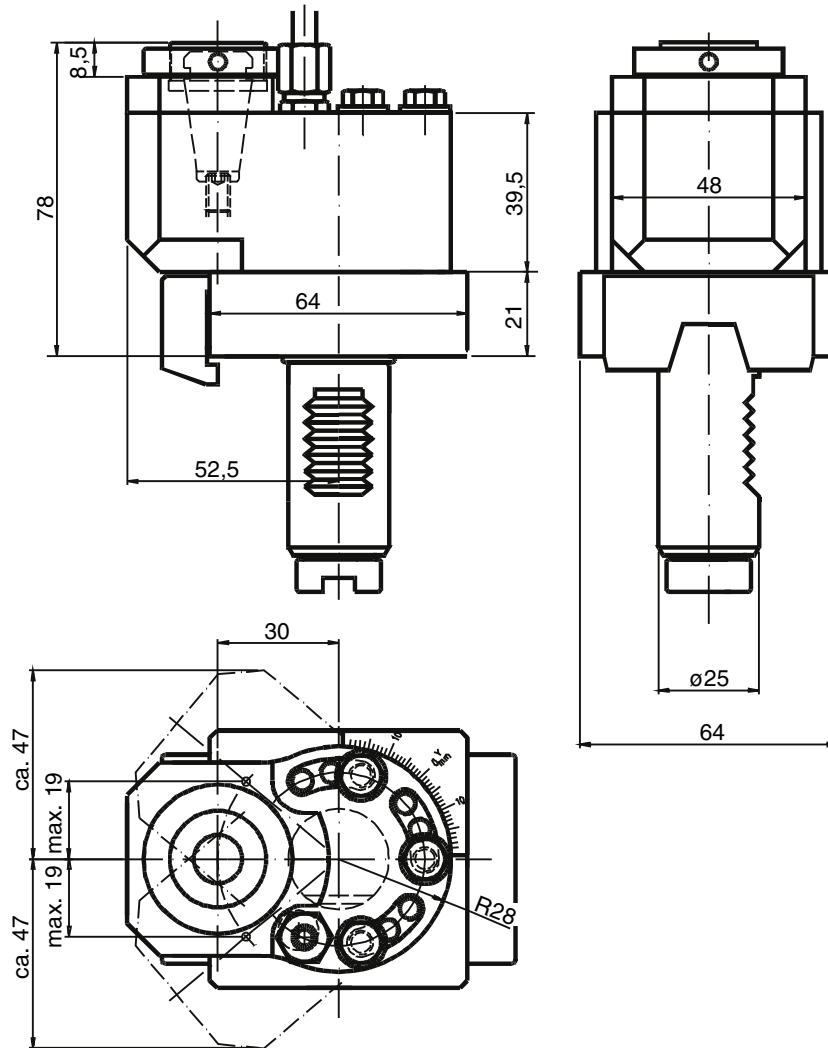

Bestell Nr Order No.	i	n_{max} [1/min]	T_{max} [Nm]	Spannzange (siehe 1.27) Collet (see 1.27)
56.2516 G200 (V)	1:1	6000	12	RD/ER 16 426 E (1-10)



Statische- und angetriebene Werkzeuge Schaft Ø25 für:

*Static and driven tools shank Ø25 for:
Porte-outils statiques et motorisés VDI25 pour:*

Index ABC

Ausgleichhalter

Werkzeugaufnahme
für VDI 20 Werkzeuge

Adaptor

Tooladaptor for
VDI 20 Toolholders

Adapteur

pour VDI 20

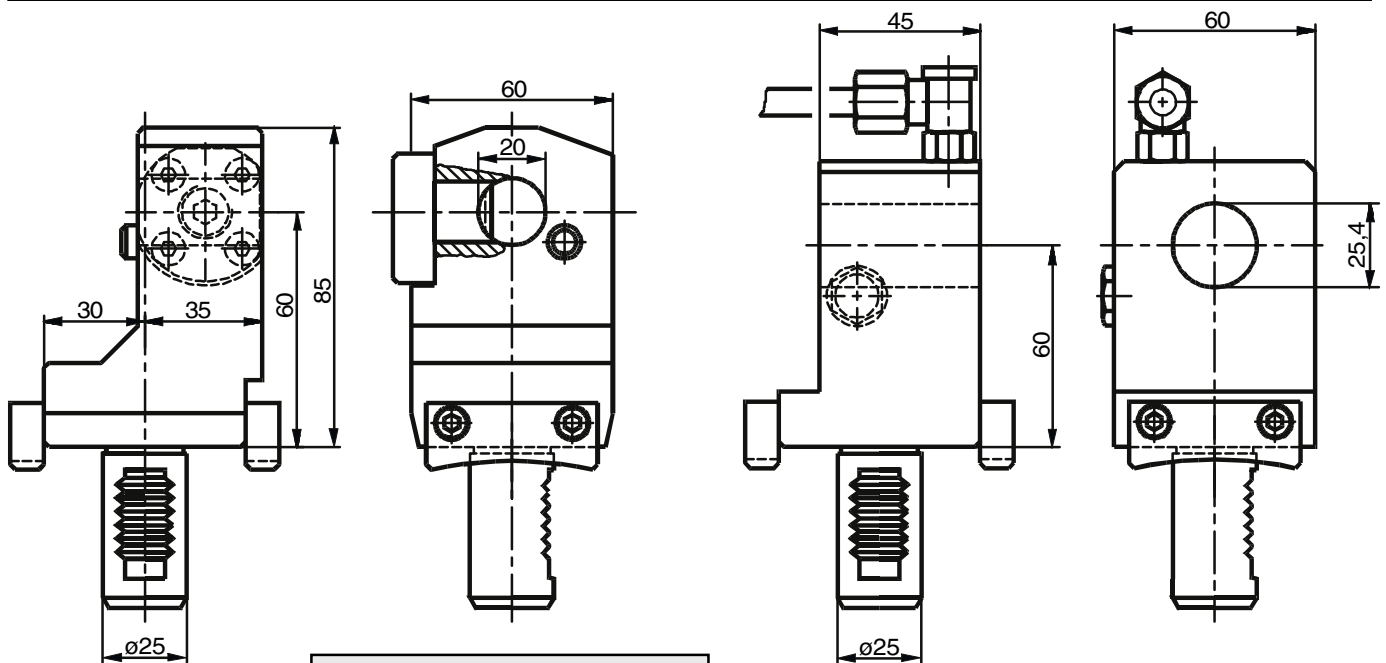

Mit V-Leiste, bitte **V** hinter Bestell-Nr. angeben, z.B. WA 2520 ABC **V** (Lizenz Index)

With V-plate, please add **V** behind the part No. for ex. WA 2520 ABC **V** (licence Index)

Nr. / No.
WA 2520 ABC (V)

Nr. / No.
WA 2525.4 ABC (V)

Bohrhalter

Drill Holder

Porte-foret

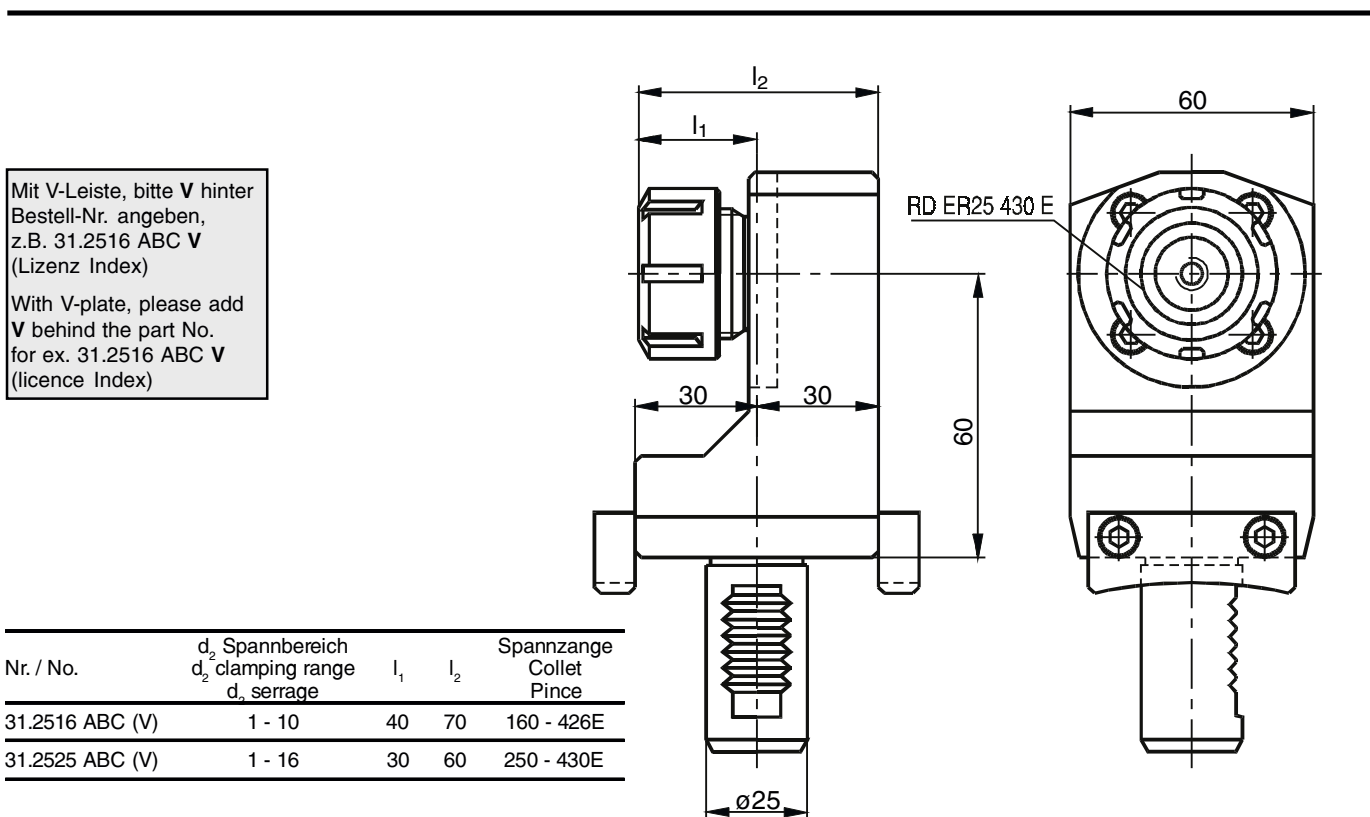

Mit V-Leiste, bitte **V** hinter Bestell-Nr. angeben, z.B. 31.2516 ABC **V** (Lizenz Index)
With V-plate, please add **V** behind the part No. for ex. 31.2516 ABC **V** (licence Index)

Nr. / No.	d ₂ Spannbereich d ₂ clamping range d, serrage	l ₁	l ₂	Spannzange Collet Pince
31.2516 ABC (V)	1 - 10	40	70	160 - 426E
31.2525 ABC (V)	1 - 16	30	60	250 - 430E

Kombihalter

Combi holder

Porte-outil combiné

Nr. / No.

17.2525 ABC (V)

Einsätze siehe Seite 4.62
Accessories see 4.62
Accessoires page 4.62

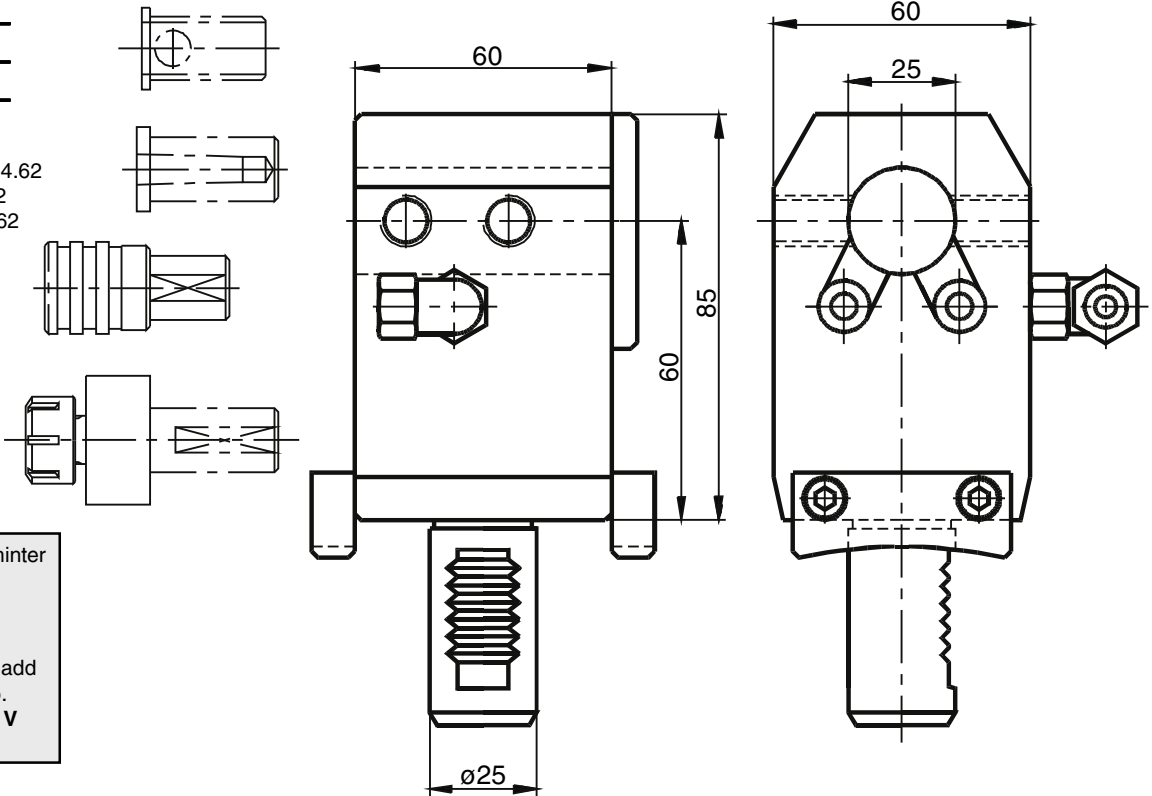

Mit V-Leiste, bitte **V** hinter Bestell-Nr. angeben, z.B. 17.2525 ABC **V** (Lizenz Index)
With V-plate, please add **V** behind the part No. for ex. 17.2525 ABC **V** (licence Index)

Kombihalter und Aufnahmehülsen

Combi holder and adaptor sleeve

Porte-outil combiné et douille de réduction

Nr. / No.

17.2532 ABC (V)

Mit V-Leiste, bitte **V** hinter Bestell-Nr. angeben, z.B. 17.2532 ABC **V** (Lizenz Index)
With V-plate, please add **V** behind the part No. for ex. 17.2532 ABC **V** (licence Index)

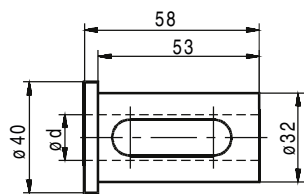

Nr. / No.	d
28.3206 G200	06
28.3208 G200	08
28.3210 G200	10
28.3212 G200	12
28.3216 G200	16
28.3220 G200	20
28.3225 G200	25
28.3225,4 G200	25,4 (1")

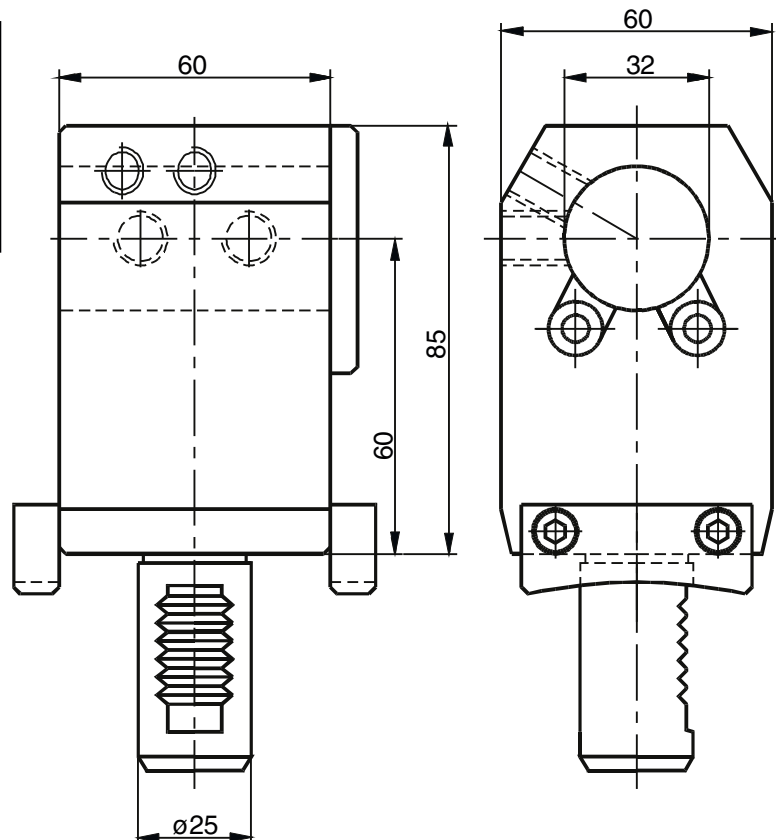

Werkstoffanschlag

Stock stop

**Porte-outil à buté
de longueur**

Nr. / No.
25.500 ABC

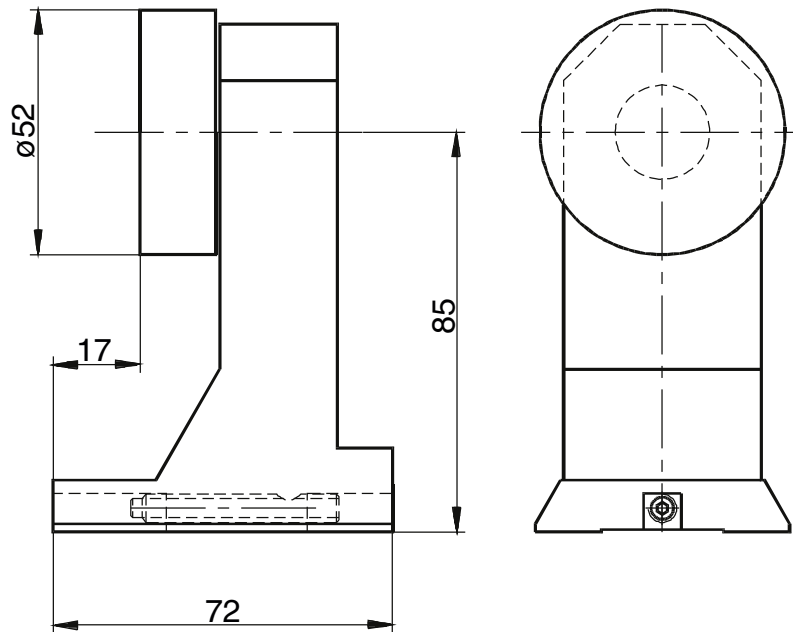

Werkstoffanschlag
Zurückgesetzt

Stock stop
offset

**Porte-outil à buté
de longueur**

Nr. / No.
25.500L ABC

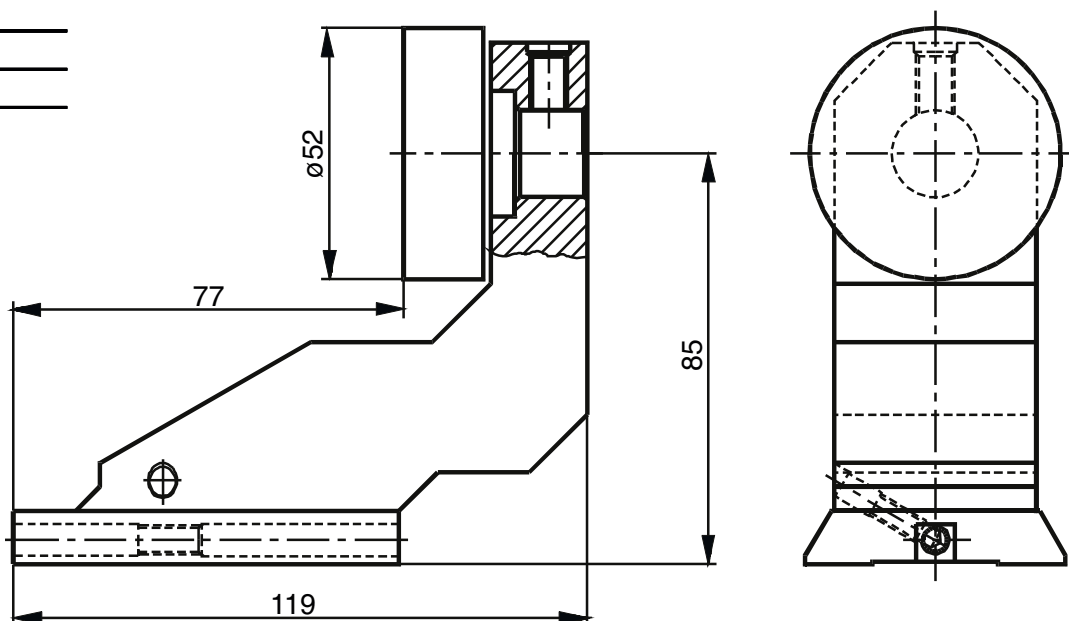

**Stechhalter mit
Höheneinstellung**

**Infeed Tool Holder
with height adjustment**

**Porte-outil de plongée
à réglage vertical de
centrage**

Nr. / No.

001.0000 ABC

Wechselhalter siehe Seite 4.65

Accessories see page 4.65

Accessoires page 4.65

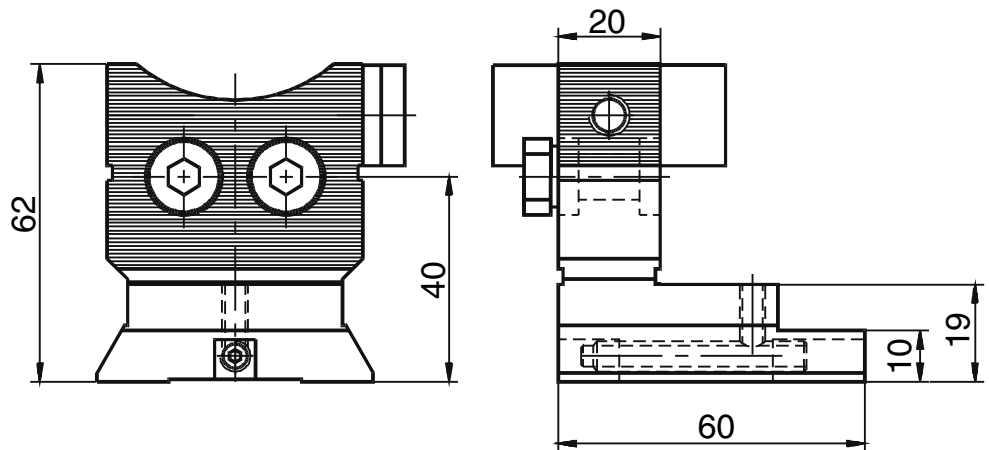

Drehhalter

Turning toolholder

Porte-outil detournage

Nr. / No.

10.250 ABC

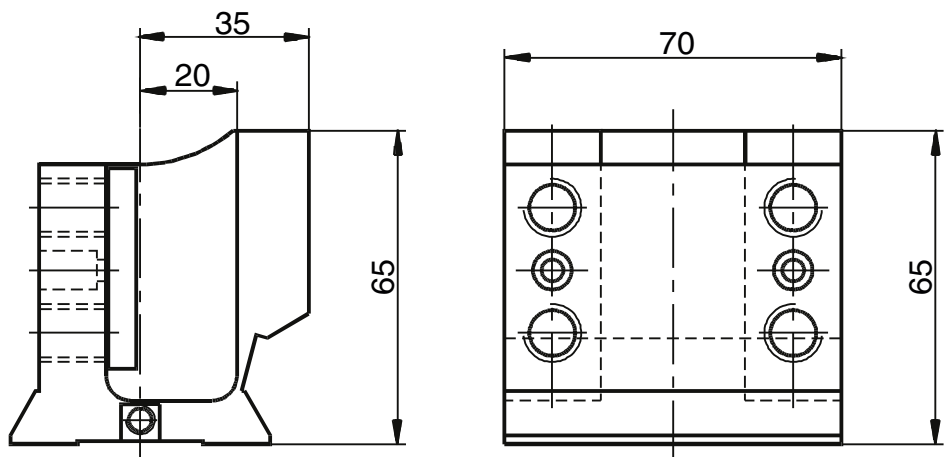

Drehhalter

Turning toolholder

Porte-outil detournage

Nr. / No.

10.250 LABC

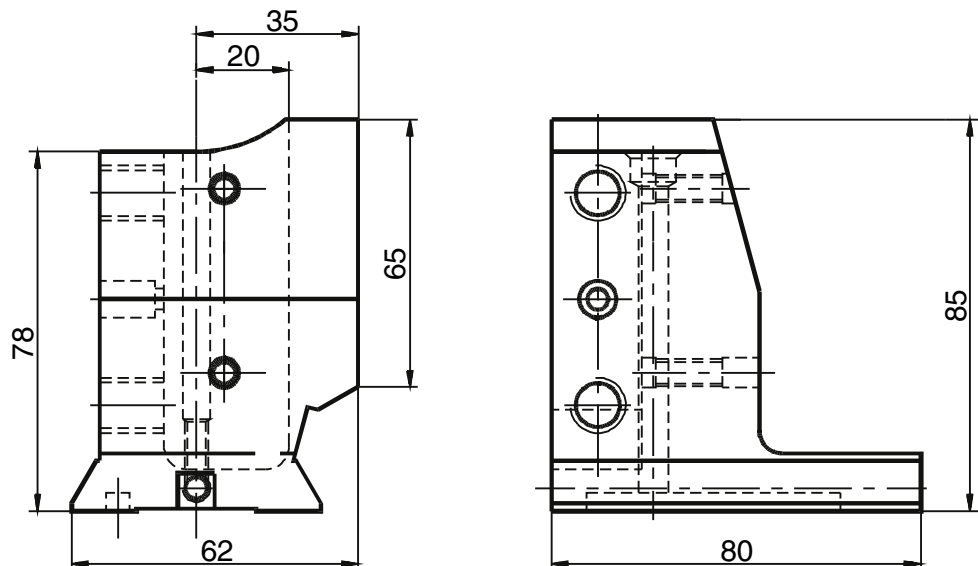

Werkzeughalter

Toolholder blank

Ébanche de porte-outil

vorbearbeitet

Nr. / No.
RABC 75.108

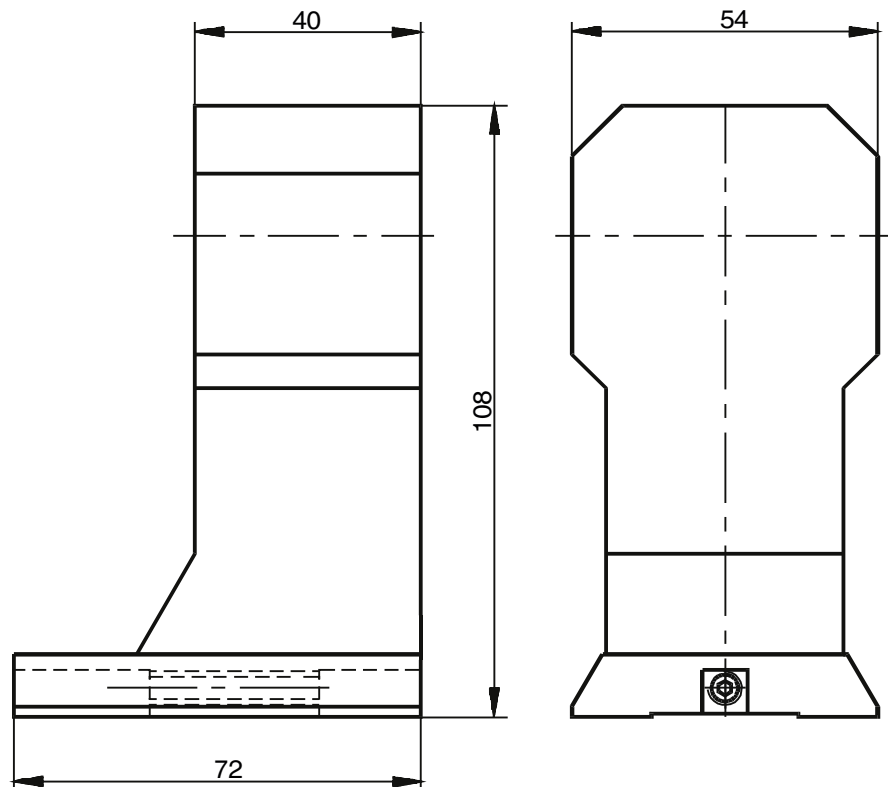

4

Bohrstangenaufnahme

Boring bar holder

Porte barre d'alésage

Nr. / No.
19. ABC 32

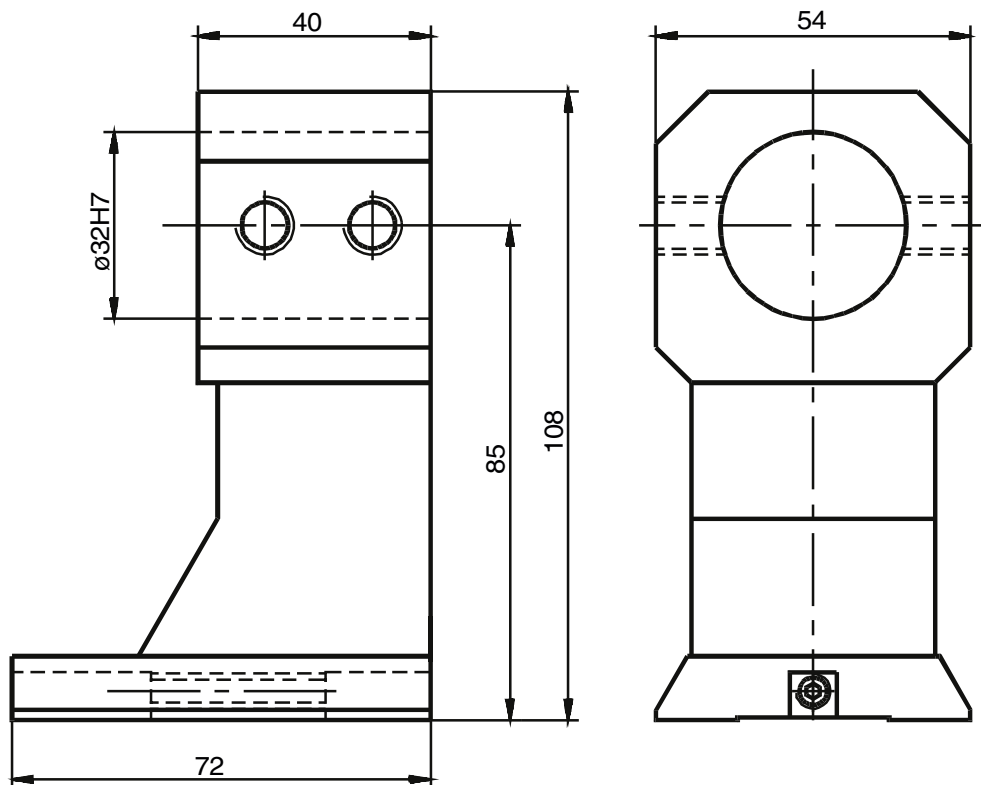

Ausgleichhalter

Werkzeugaufnahme
für VDI 20 Werkzeuge

Adaptor

Tool adaptor for
VDI 20 Tool holders

Adapteur

pour VDI 20

Nr. / No.
WA 20 ABC

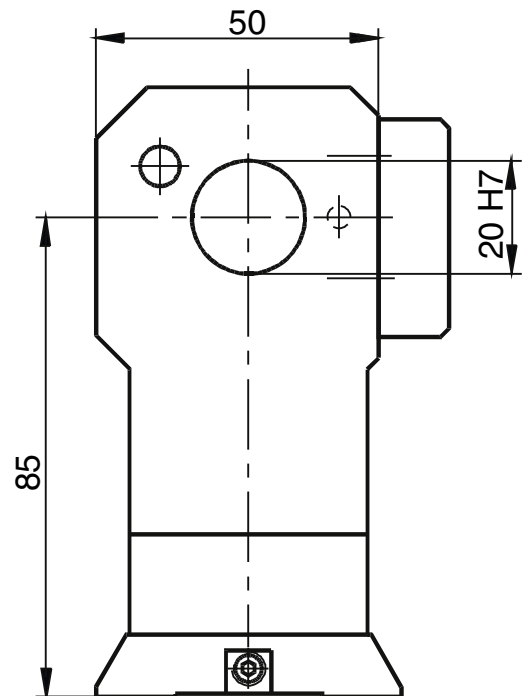
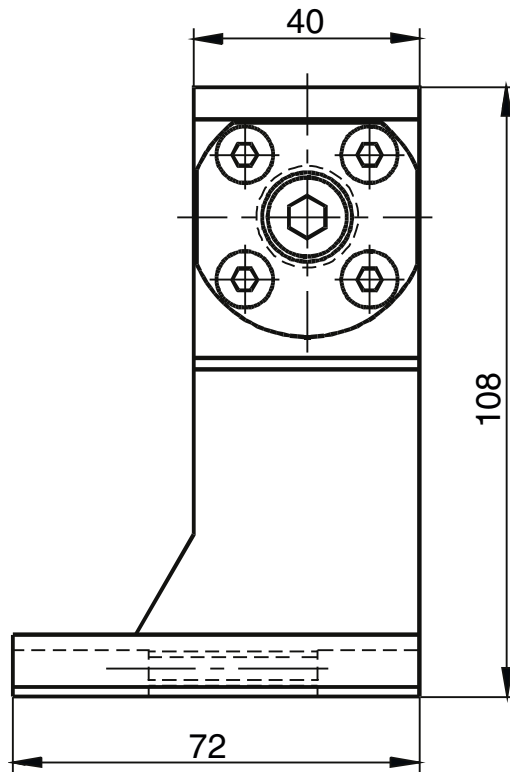

Bohrhalter

Drillholder

Porte-foret

Nr. / No.
31. ABC 25

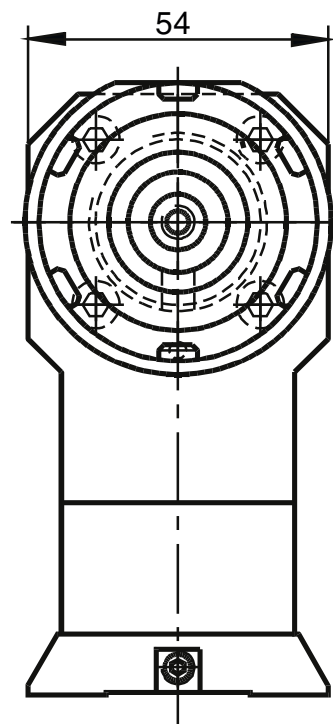
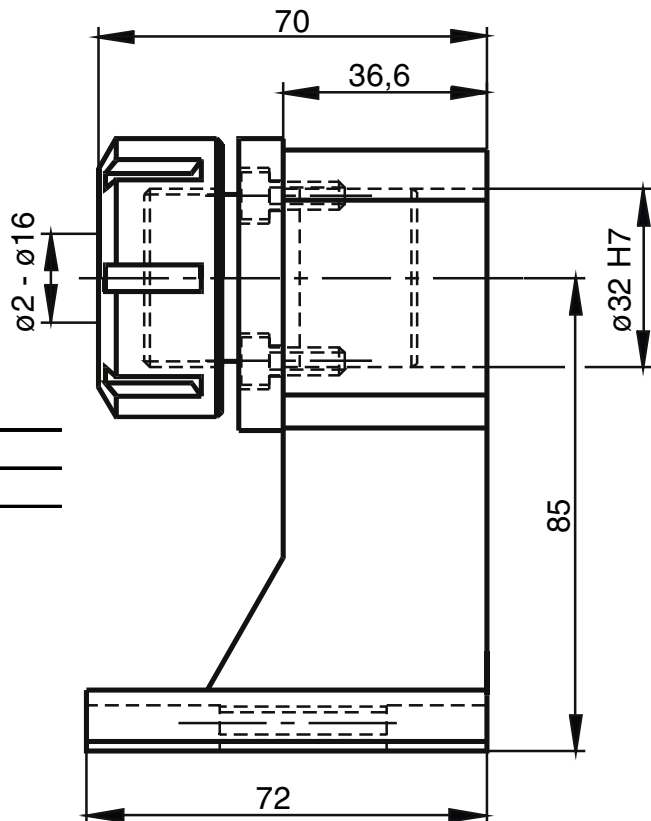

Pinole

für Hinterbohrereinrichtung
zur Aufnahme von VDI 20 Werkzeugen

Sleeve

for backside machining
with VDI 20 toolholders

Adapteur

pour VDI 20

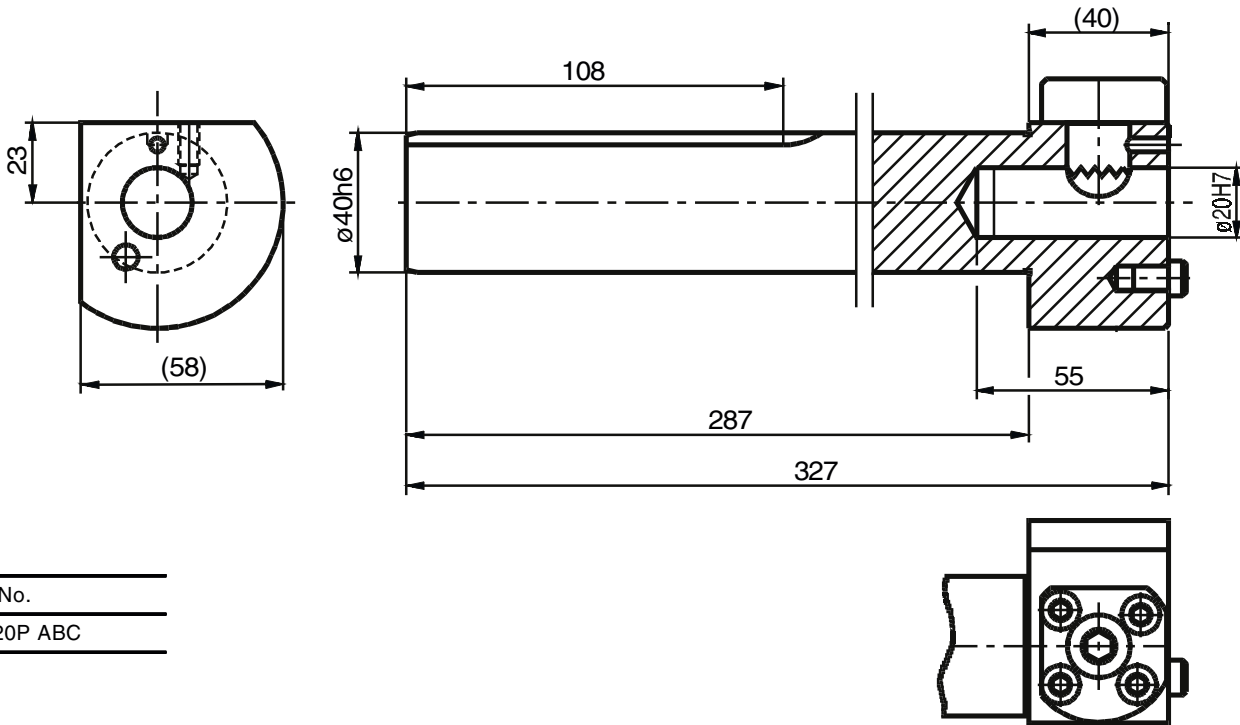

Nr. / No.

WA 20P ABC

Abdeckplatte

Plate

Flasque

Nr. / No.

29. ABC

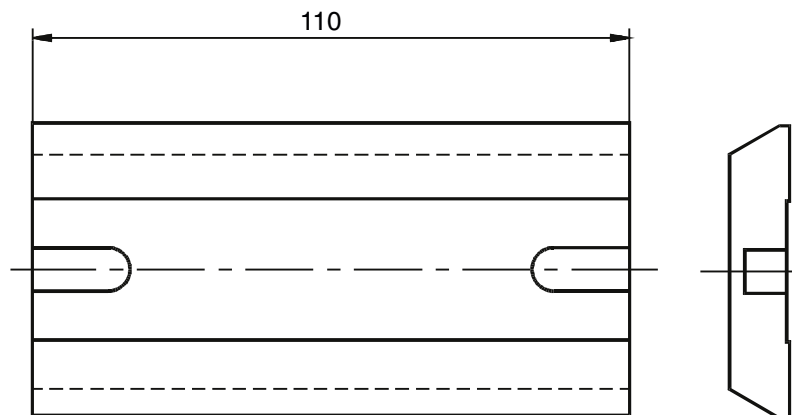



**Axial Bohr-
und Fräskopf**

**Axial drilling and
milling head**

**Tête de perçage
et fraisage**

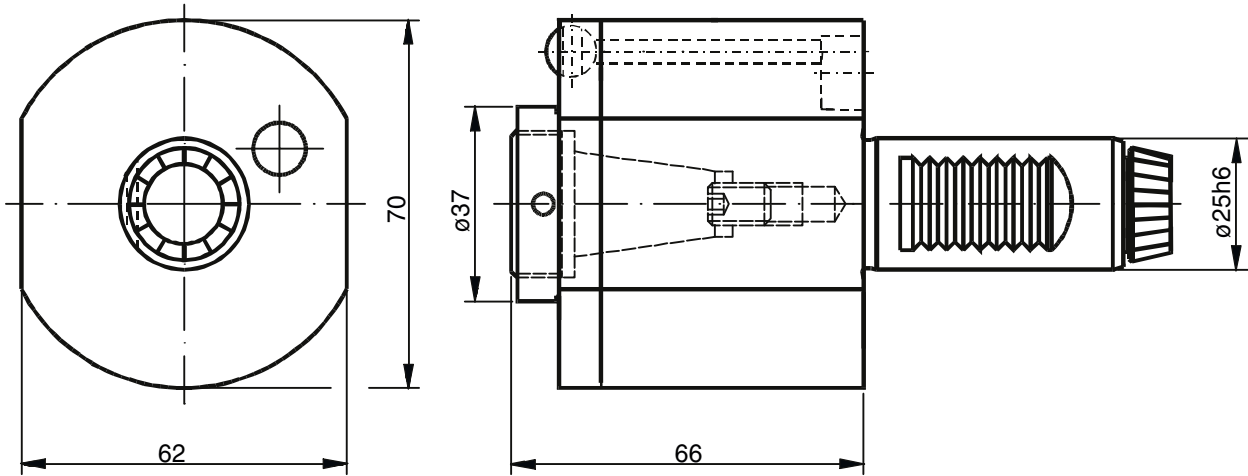

Innere Kühlmittelzufuhr. Zusatz IK an Bestellnummer anfügen.
Central cooling supply. Please add IK behind order no.

Bestell Nr. Order No.	i	n_{max} [1/min]	T_{max} [Nm]	Schlüsselsatz Wrench-set	Spannzange (siehe 1.27) Collet (see 1.27)
40.2520 ABC	1:1	6000	16	LS20/HS40	RD/ER 20 428E (1-13)

**Axial Bohr-
und Fräskopf**

**Axial drilling and
milling head**

**Tête de perçage
et fraisage**

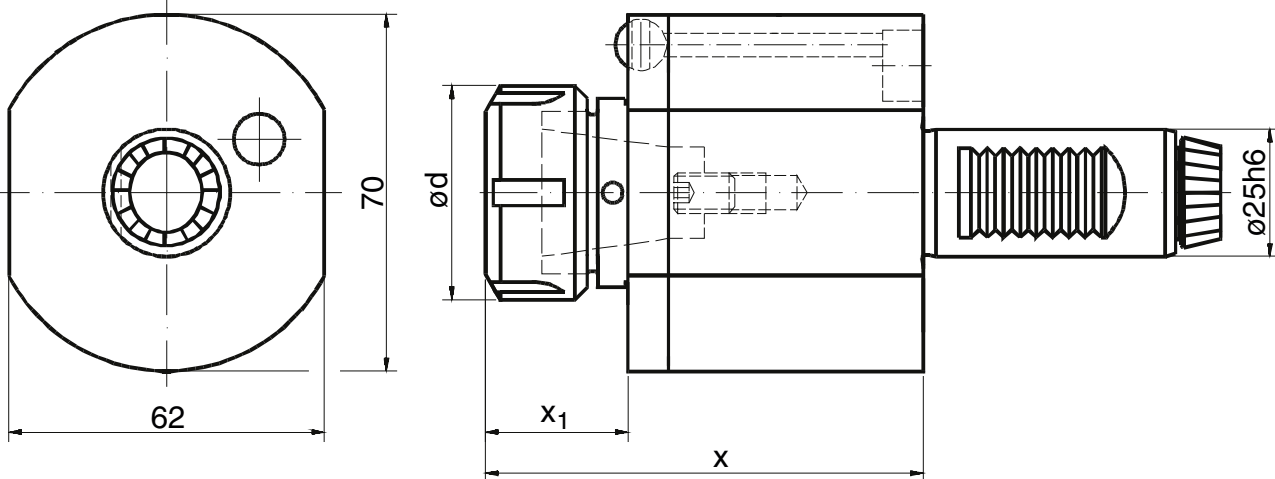

Innere Kühlmittelzufuhr. Zusatz IK an Bestellnummer anfügen.
Central cooling supply. Please add IK behind order no.

Bestell Nr. Order No.	i	d	x	x_1	n_{max} [1/min]	T_{max} [Nm]	Schlüsselsatz Wrench-set	Spannzange (siehe 1.27) Collet (see 1.27)
40.2520 ABC AM	1:1	35	78	27	6000	16	220/HS40	RD/ER 20 428E (1-13)
40.2525 ABC	1:1	42	79	28	6000	16	225/HS40	RD/ER 25 430E (2-15)

Axial Bohr- und Fräskopf

Axial drilling and milling head

Tête de perçage et fraisage

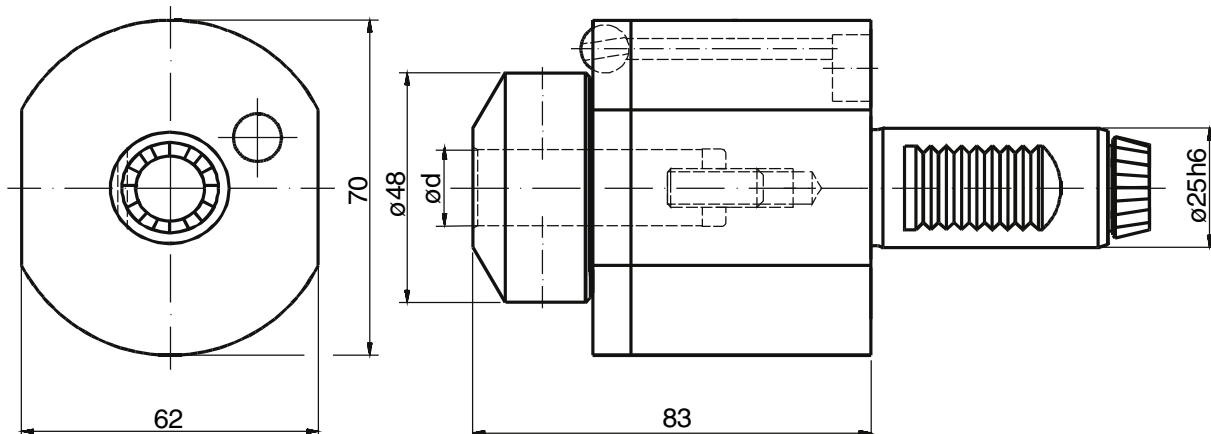

Innere Kühlmittelzufuhr. Zusatz IK an Bestellnummer anfügen.
Central cooling supply. Please add IK behind order no.

Bestell Nr. Order No.	i	d	n_{\max} [1/min]	T_{\max} [Nm]
40.2516 WN ABC	1:1	16	6000	16
40.2512 WN ABC	1:1	12	6000	16
40.2510 WN ABC	1:1	10	6000	16

Axial Bohr- und Fräskopf

Axial drilling and milling head

Tête de perçage et fraisage

NEWS
i = 1:2

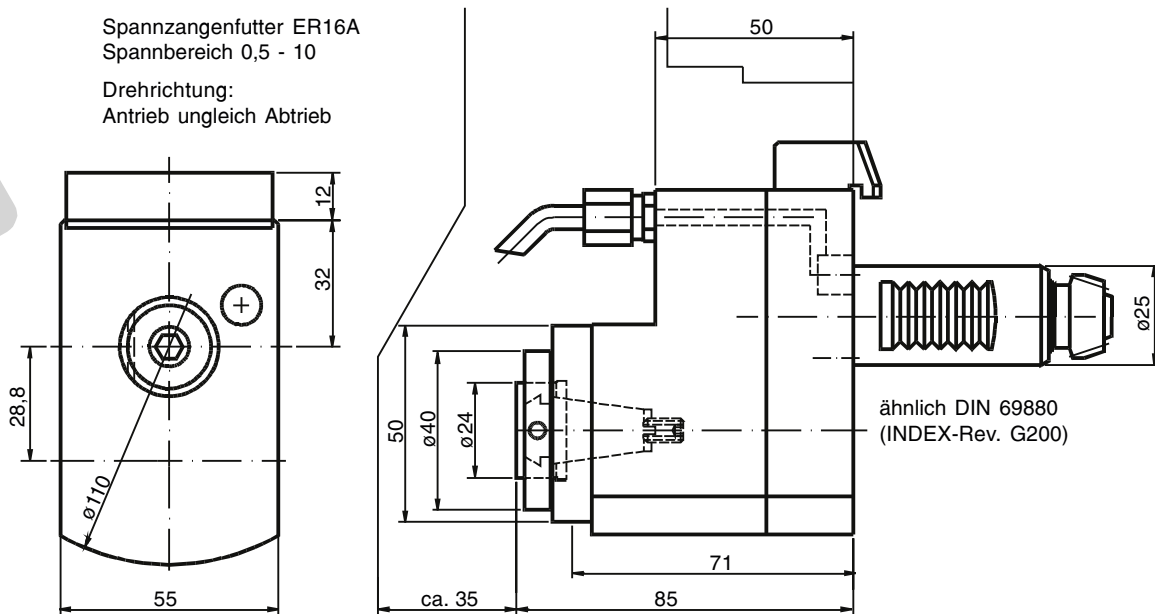

Spannzangenfutter ER16A
Spannbereich 0,5 - 10

Drehrichtung:
Antrieb ungleich Abtrieb

Innere Kühlmittelzufuhr. Zusatz IK an Bestellnummer anfügen.
Central cooling supply. Please add IK behind order no.

Bestell Nr. Order No.	i	n_{\max} [1/min]	T_{\max} [Nm]	Schlüsselsatz Wrench-set	Spannzange (siehe 1.27) Collet (see 1.27)
50.2516 ABC/1	1:2	12000	8	LS16/HS40	RD/ER 16 426E (1-10)

Axial Gewindebohrkopf

Axial tapping head

Tête de taraudage

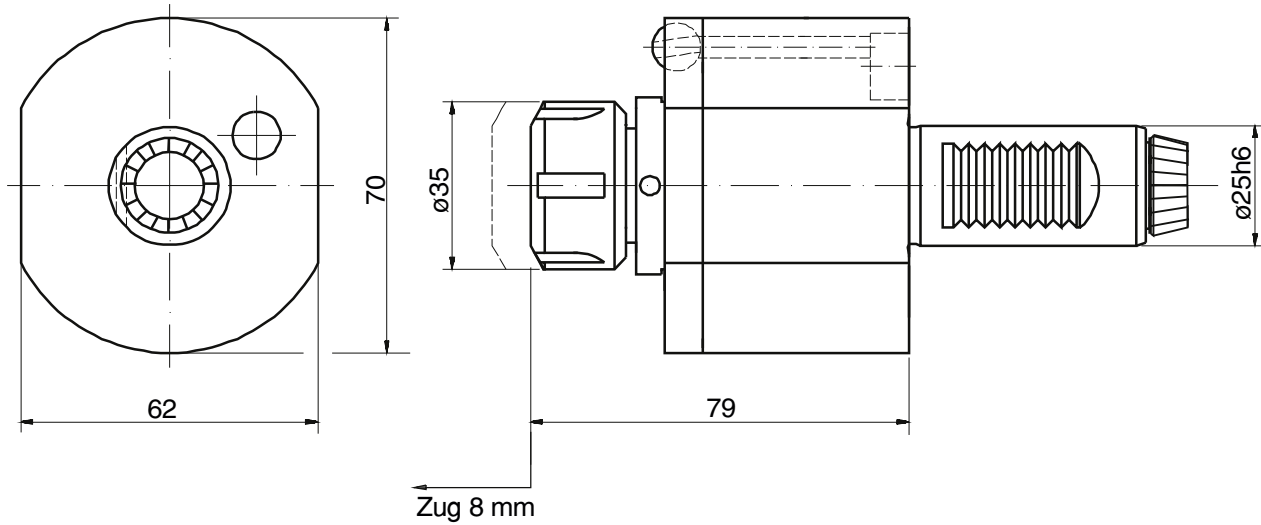

Bestell Nr. Order No.	i	n_{max} [1/min]	T_{max} [Nm]	Schlüsselsatz Wrench-set	Spannzange (siehe 1.27) Collet (see 1.27)
41.2520 ABC	1:1	6000	16	GS30/GS22	RD/ER 20 428E (1-13)

Radial Bohr- und Fräskopf

Radial drilling and milling head

Tête de perçage et fraisage radial

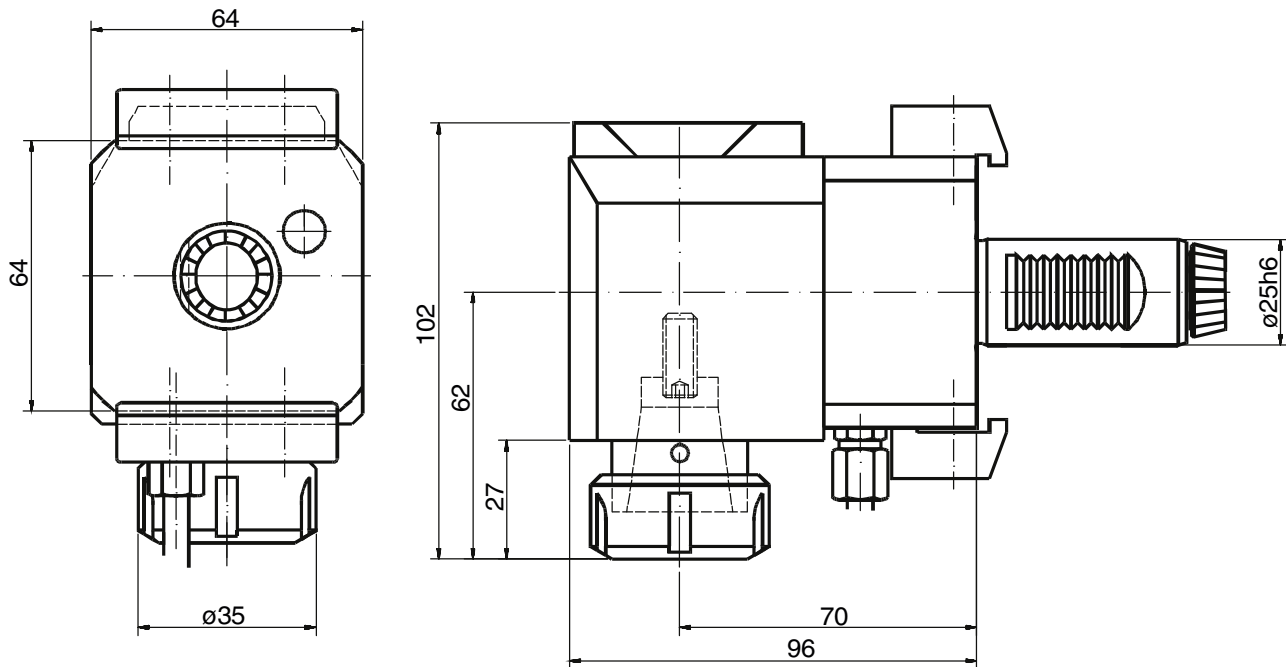

Innere Kühlmittelzufuhr. Zusatz IK an Bestellnummer anfügen.
Central cooling supply. Please add IK behind order no.

Bestell Nr. Order No.	i	n_{max} [1/min]	T_{max} [Nm]	Schlüsselsatz Wrench-set	Spannzange (siehe 1.27) Collet (see 1.27)
60.2520 ABC (V)	1:1	6000	16	GS30/HS40	RD/ER 20 428E (1-13)
60.2520 ABC/1 (V)	1:2	12000	16	GS30/HS40	RD/ER 20 428E (1-13)
60.2520 ABC/2 (V)	2:1	6000	32	GS30/HS40	RD/ER 20 428E (1-13)

Mit V-Leiste, bitte V hinter Bestell-Nr. angeben,
z.B. 60.2520 ABC V
(Lizenz Index)

With V-plate, please add V behind the part No.
for ex. 60.2520 ABC V
(licence Index)

Radial Bohr- und Fräskopf

Radial drilling and milling head

Tête de perçage et fraisage radial

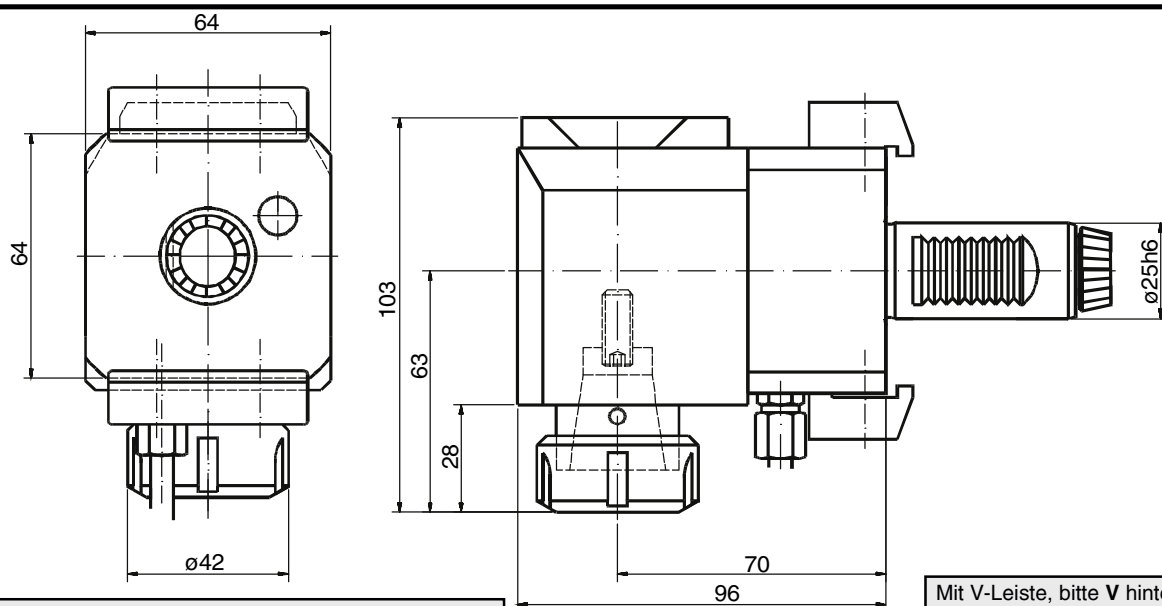

Innere Kühlmittelzufuhr. Zusatz IK an Bestellnummer anfügen.
Central cooling supply. Please add IK behind order no.

Mit V-Leiste, bitte V hinter Bestell-Nr. angeben, z.B. 60.2525 ABC V (Lizenz Index)

With V-plate, please add V behind the part No. for ex. 60.2525 ABC V (licence Index)

Bestell Nr. Order No.	i	n_{max} [1/min]	T_{max} [Nm]	Schlüsselsatz Wrench-set	Spannzange (siehe 1.27) Collet (see 1.27)
60.2525 ABC (V)	1:1	6000	16	225/HS40	RD/ER 25 430E (2-16)
60.2525 ABC/2 (V)	2:1	6000	32	225/HS40	RD/ER 25 430E (2-16)

Radial Bohr- und Fräskopf

Radial drilling and milling head

Tête de perçage et fraisage radial

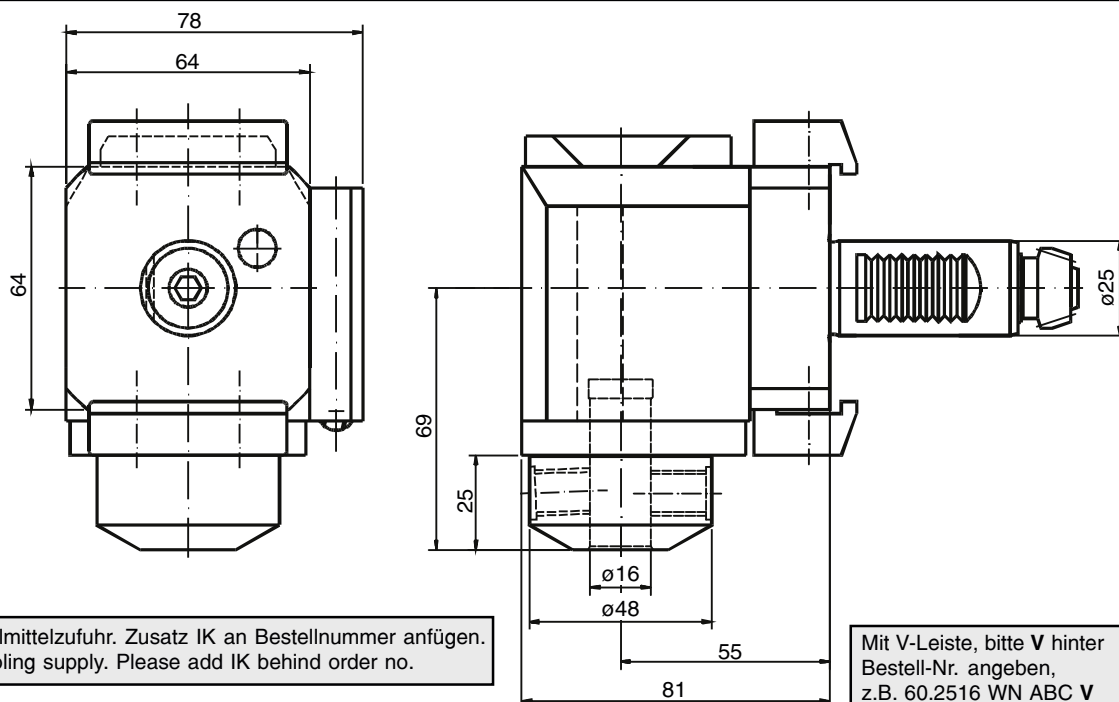

Innere Kühlmittelzufuhr. Zusatz IK an Bestellnummer anfügen.
Central cooling supply. Please add IK behind order no.

Mit V-Leiste, bitte V hinter Bestell-Nr. angeben, z.B. 60.2516 WN ABC V (Lizenz Index)

With V-plate, please add V behind the part No. for ex. 60.2516 WN ABC V (licence Index)

Bestell Nr. Order No.	i	n_{max} [1/min]	T_{max} [Nm]
60.2516 WN ABC (V)	1:1	6000	16
60.2516 WN ABC/2 (V)	2:1	6000	32

Andere \varnothing auf Anfrage / Other \varnothing on request.

**Radial
Gewindebohrkopf**

**Radial
tapping head**

**Tête de taraudage
radial**

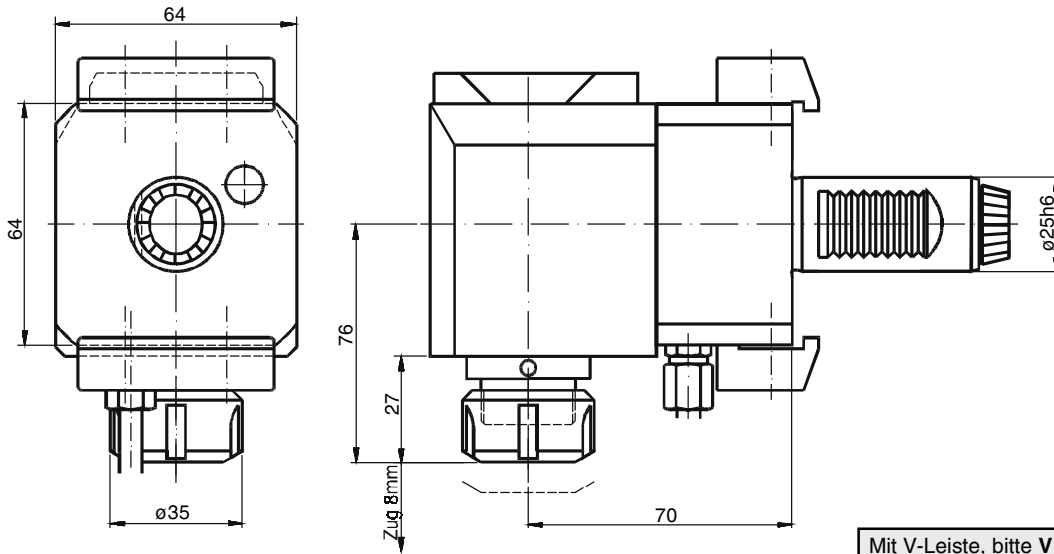

Innere Kühlmittelzufuhr. Zusatz IK an Bestellnummer anfügen.
Central cooling supply. Please add IK behind order no.

Mit V-Leiste, bitte V hinter Bestell-Nr. angeben,
z.B. 61.2520 ABC V
(Lizenz Index)

With V-plate, please add V behind the part No.
for ex. 61.2520 ABC V
(licence Index)

Bestell Nr. Order No.	i	n _{max} [1/min]	T _{max} [Nm]	Schlüsselsatz Wrench-set	Spannzange (siehe 1.27) Collet (see 1.27)
61.2520 ABC (V)	1:1	6000	16	GS30/GS22	RD/ER 25 428E (1-13)

**Radial
Fräskopf**

**Radial
milling head**

**Tête
fraisage radial**

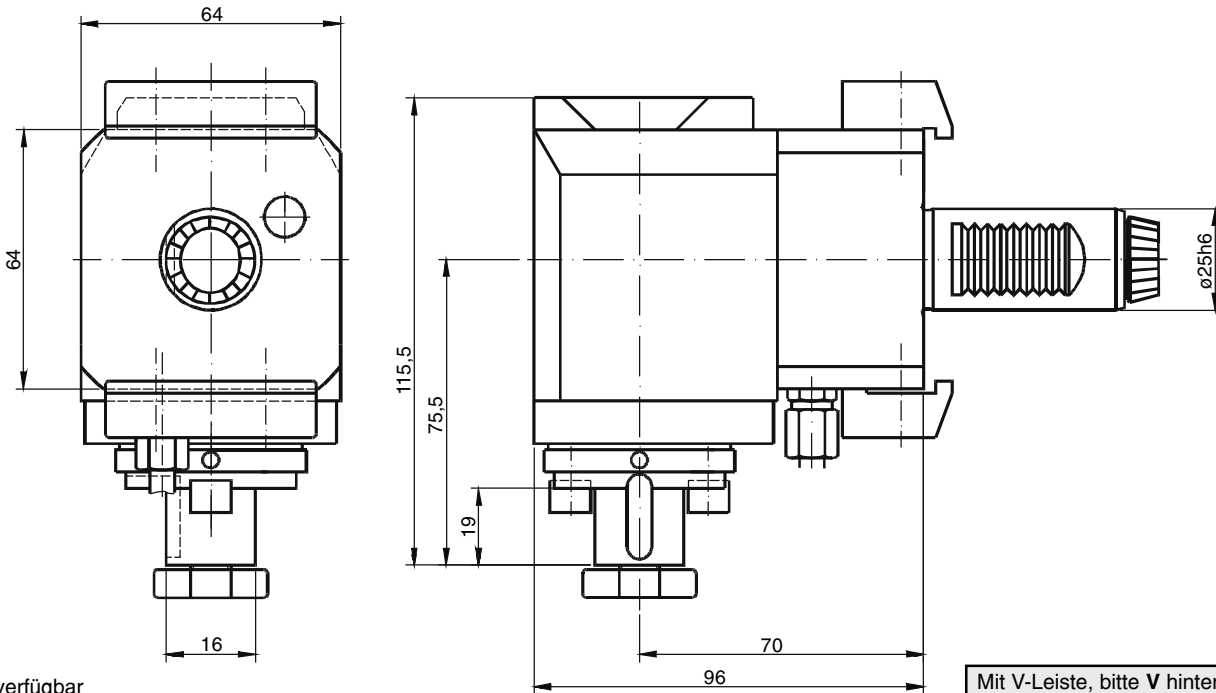

Andere ø verfügbar
Other ø available
Autre ø possible

Mit V-Leiste, bitte V hinter Bestell-Nr. angeben,
z.B. 62.2516 ABC V
(Lizenz Index)

With V-plate, please add V behind the part No.
for ex. 62.2516 ABC V
(licence Index)

Bestell Nr. Order No.	i	n _{max} [1/min]	T _{max} [Nm]
62.2516 ABC (V)	1:1	6000	25
62.2516 ABC/2 (V)	2:1	6000	40

Radial Bohr- und Fräskopf 180° schwenkbar

Radial drilling and milling head, swivel 180°

Tête de perçage et fraisage radial, pivotante 180°

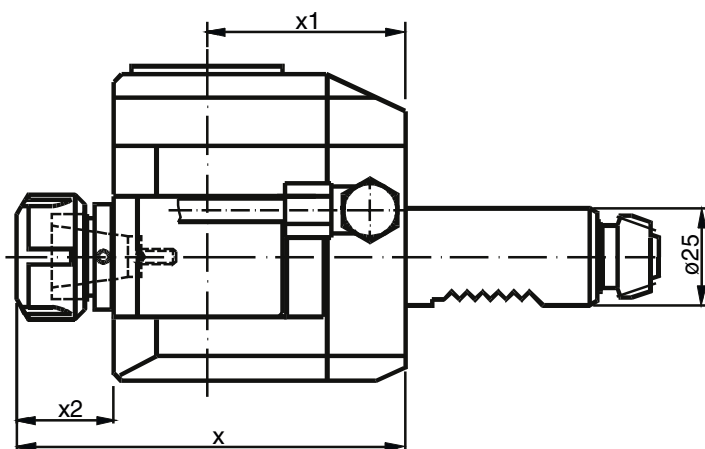
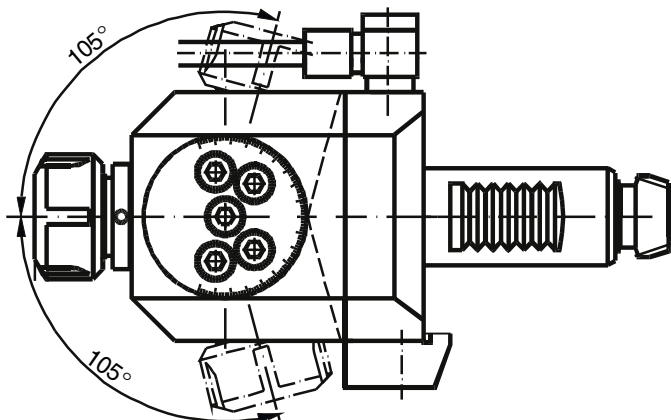
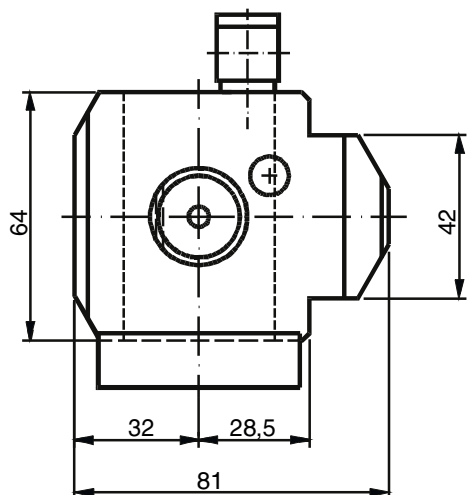

Bestell Nr. Order No.	i	X	X ₁	X ₂
63.2516 ABC/1	1:2	100	51	25
63.2520 ABC	1:1	115	58	26

Bestell Nr. Order No.	n _{max} [1/min]	T _{max} [Nm]	Spannzange (siehe 1.27) Collet (see 1.27)
63.2516 ABC/1	10000	6	RD/ER 16 426E (1-10)
63.2520 ABC	5000	16	RD/ER 20 428E (1-13)

Radial Scheiben- fräserkopf

Radial drilling head for side milling cutters

Tête de fraisage radial pour fraise scie

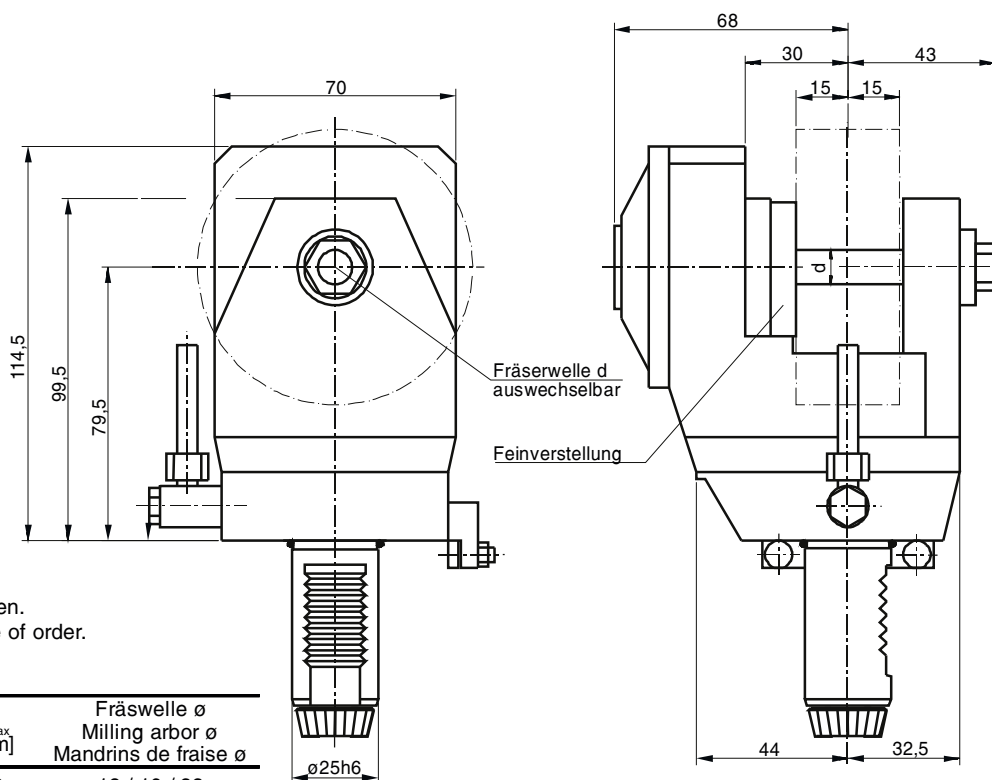

Fräserwelle \varnothing bei Bestellung angeben.
Milling arbor \varnothing please inform in case of order.
Beispiel / Example 64.2516 ABC

Bestell Nr. Order No.	i	n _{max} [1/min]	T _{max} [Nm]	Fräserwelle \varnothing Milling arbor \varnothing Mandrins de fraise \varnothing
64.25.. ABC	2,55:1	2000	40	13 / 16 / 22

Querfräskopf

Angle milling head

**Tête de fraisage
angulaire**

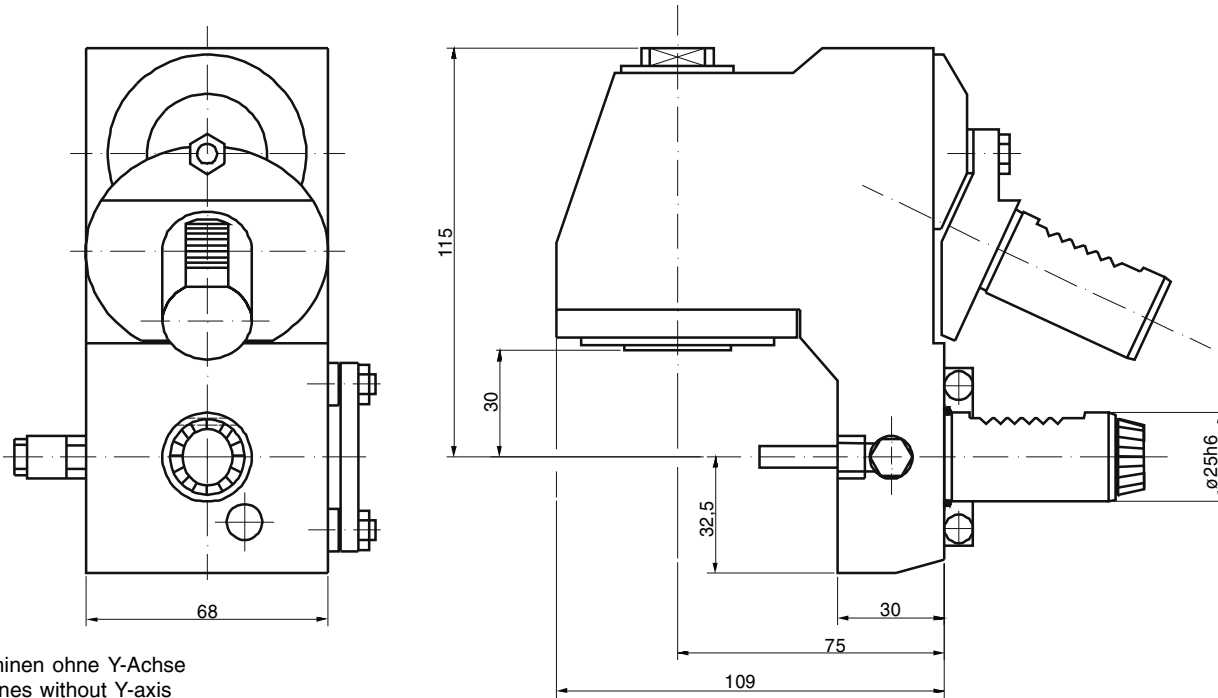

Für Maschinen ohne Y-Achse
For machines without Y-axis

Bestell Nr. Order No.	i	n_{max} [1/min]	T_{max} [Nm]	Schlüsselsatz Wrench-set	Spannzange (siehe 1.27) Collet (see 1.27)
65.2520 ABC	2:1	6000	32	LS20/	RD/ER 20 428E (1-13)

4

**Axial Bohr-
und Fräskopf**

y-verstellbar

**Axial drilling and
milling head**

y-axis adjustable

**Tête de perçage
et fraisage axial**

y-axis adjustable

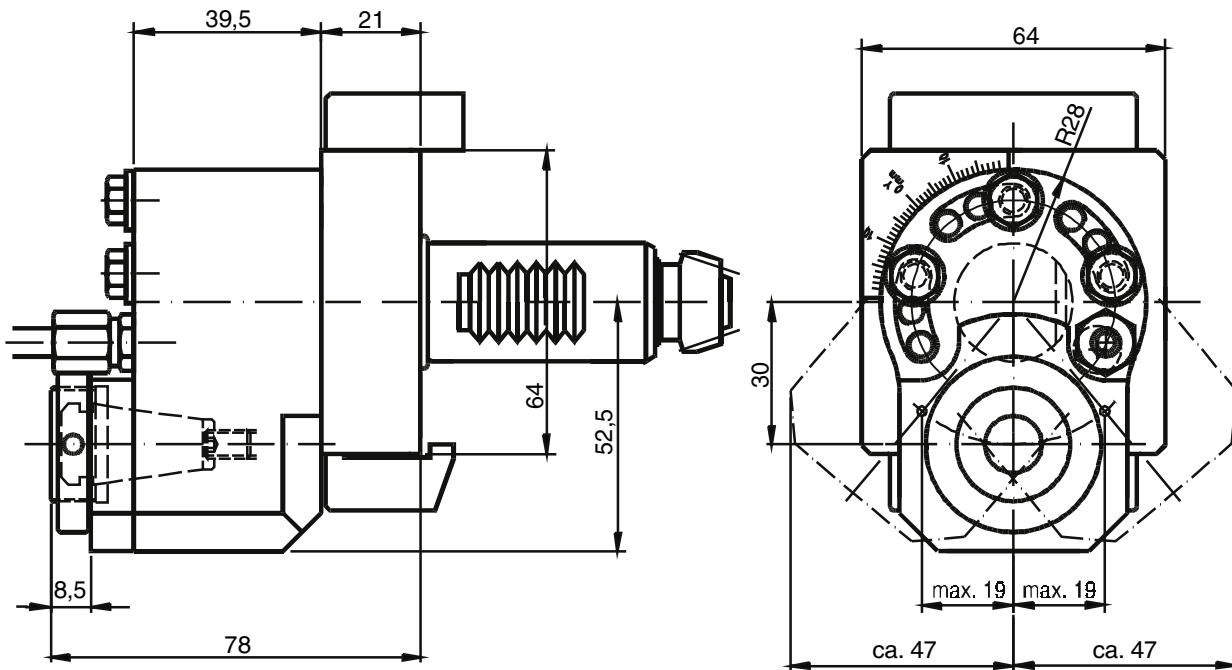

Bestell Nr. Order No.	i	n_{max} [1/min]	T_{max} [Nm]	Spannzange (siehe 1.27) Collet (see 1.27)
56.2516 ABC	1:1	6000	16	RD/ER 16 426E (1-10)

Axial Fräskopf

Axial milling head

Tête de fraisage axial

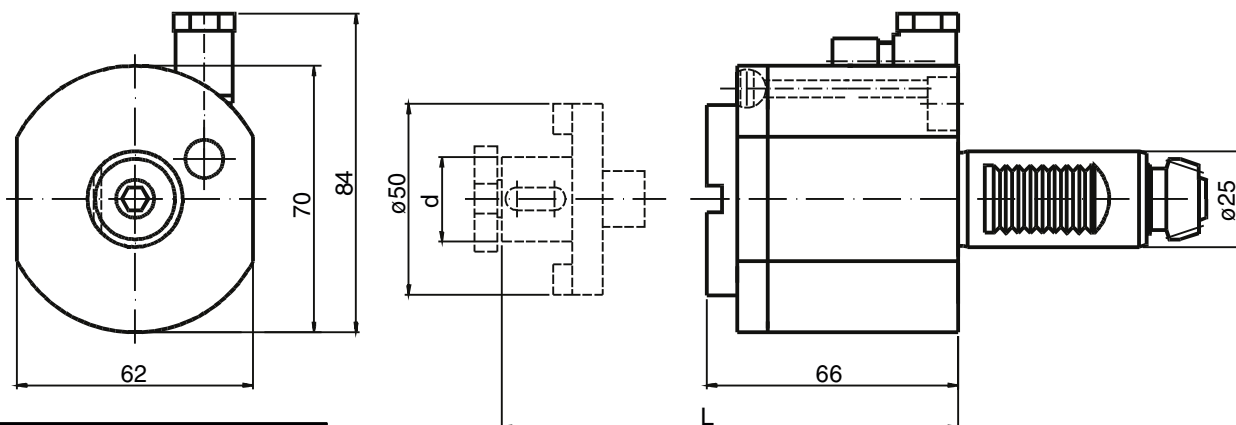

Bestell Nr. Order No.	i	n_{max} [1/min]	T_{max} [Nm]
42.2500 ABC	1:1	6000	25

Fräshaltestück

zu 42.2500 ABC

Milling arbor inserts

for 42.2500 ABC

Adaptateur de fraisage

pour 42.2500 ABC

Bestell Nr. Order No.	d	x
501.0507	13	24
501.0510	16	29
501.0520	22	31
501.0530	27	33

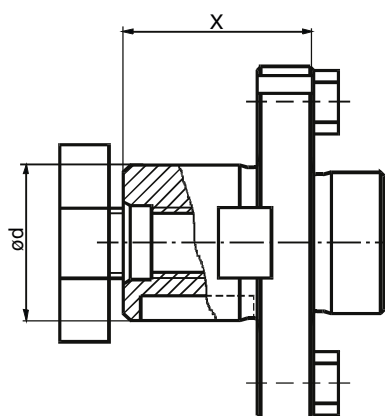

Axial Bohr- und Fräskopf

Axial drilling and milling head

Tête de perçage et fraisage axial

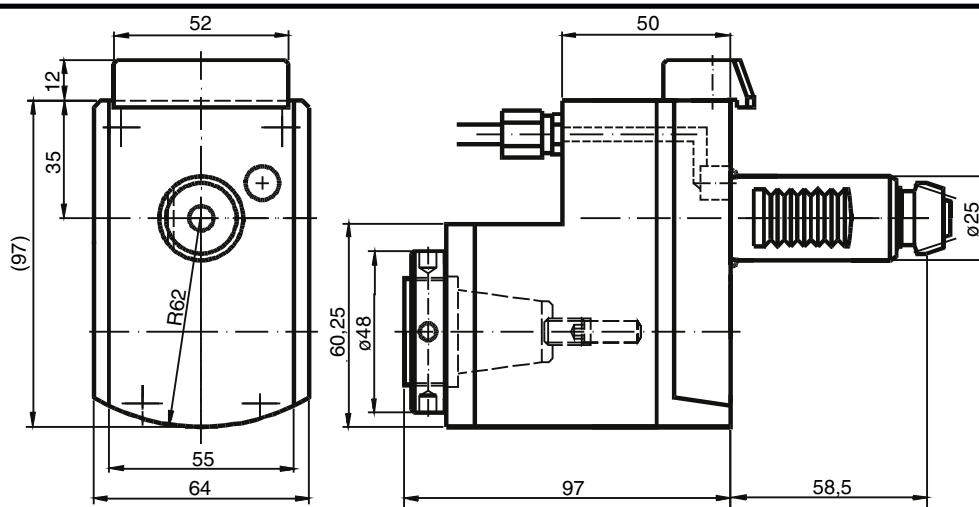

Bestell Nr. Order No.	i	n_{max} [1/min]	T_{max} [Nm]	Spannzange (siehe 1.27) Collet (see 1.27)
50.2525 ABC/2	2:1	3000	40	RD/ER 25 430E (2-16)



Statische- und angetriebene Werkzeuge Schaft Ø25 für:

*Static and driven tools shank Ø25 for:
Porte-outils statiques et motorisés VDI25 pour:*

Index G250, G300, V250, V300

Ausgleichhalter

für Werkzeugaufnahmen
mit Schaft nach DIN 69880
ø 30 x 55

Adaptor

for toolholders
DIN 69880 shaft 30

Adapteur

pour VDI 20

Nr. / No.

WA 3030 G300 R (V)

WA 3030 G300 L (V)

WA 3030 G300 RL (V)

Mit V-Leisten,
bitte hinter Bestell-Nr. angeben,
z.B. WA 3030 G300 R V

With V-plates,
please add V behind the part No.
for example WA 3030 G300 R V

Ausführung R wie gezeichnet
right hand design as shown
à droite suivant croquis

Ausführung L spiegelbildlich
left hand design reversed
à gauche inversé

Ausführung RL mit doppelverzahntem DIN-Schaft
with doubletoothed DIN shaft
universelle pour broche et contre-broche

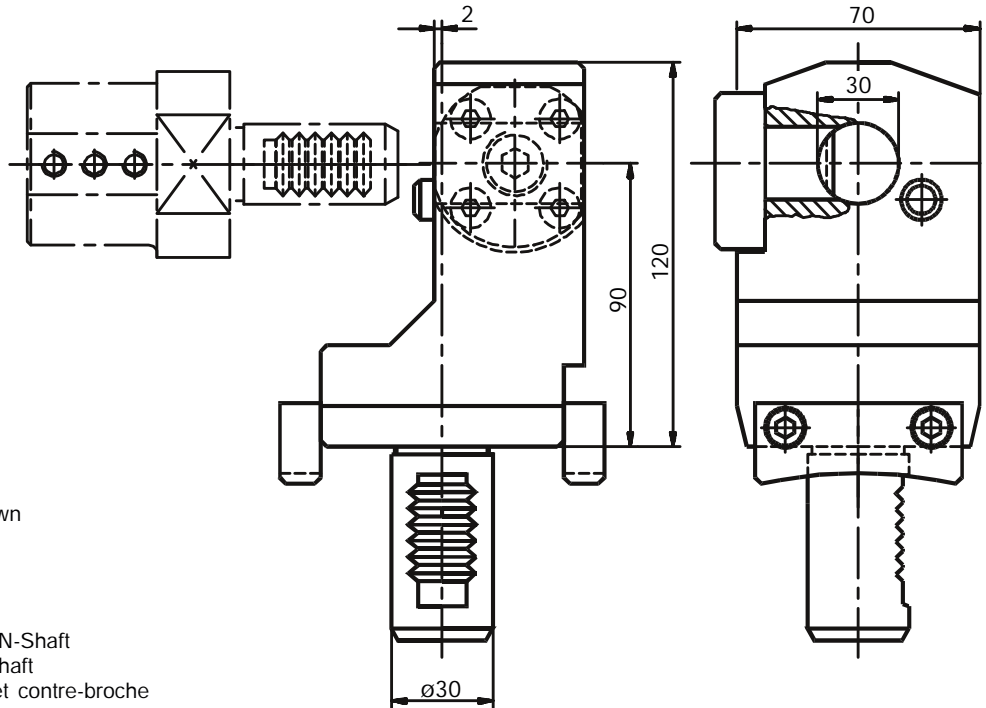

Bohrhalter

Drill Holder

Porte-foret

Ausführung R wie gezeichnet
right hand design as shown
à droite suivant croquis

Ausführung L spiegelbildlich
left hand design reversed
à gauche inversé

Ausführung RL mit doppelverzahntem DIN-Schaft
with doubletoothed DIN shaft
universelle pour broche et contre-broche

Mit V-Leisten,
bitte hinter Bestell-Nr. angeben,
z.B. 31.3032 G300 R V

With V-plates,
please add V behind the part No.
for example 31.3032 G300 R V

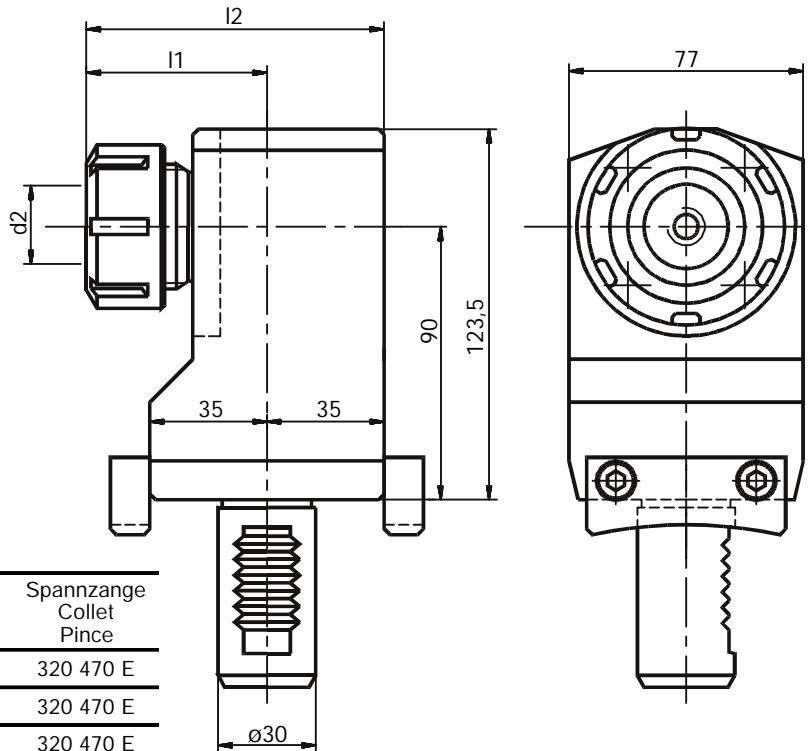

Nr. / No.	d ₂ Spannbereich d ₂ clamping range d ₂ capacité	l ₁	l ₂	Spannzange Collet Pince
31.3032 G300 R (V)	3 - 20	54	91,5	320 470 E
31.3032 G300 L (V)	3 - 20	54	91,5	320 470 E
31.3032 G300 RL (V)	3 - 20	54	91,5	320 470 E
31.3040 G300 R (V)	4 - 26	58	95,5	400 472 E
31.3040 G300 L (V)	4 - 26	58	95,5	400 472 E
31.3040 G300 RL (V)	4 - 26	58	95,5	400 472 E

Kombihalter

Combi toolholder

Porte-outil combiné

Nr. / No.	l_1	l_2
17.3025 G300 (V)	90	115
17.3025 L G300 (V)	100	125

Für Haupt- und Gegenspindel
For main and subspindle
Pour broche principal et contre-broche

Mit V-Leisten,
bitte hinter Bestell-Nr. angeben,
z.B. 17.3025 G300 V

With V-plates,
please add V behind the part No.
for example 17.3025 G300 V

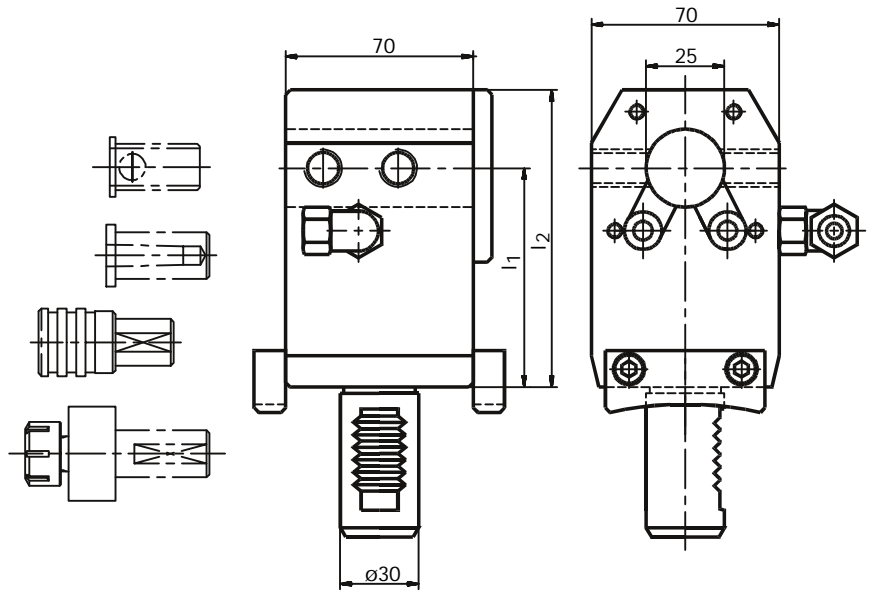

Aufnahmehülsen

Adaptor Sleeve

Douille de réduction

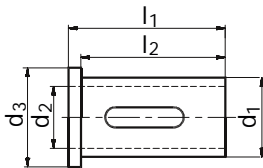

Nr. / No.	d_1	d_2	d_3	l_1	l_2
28.2520 S	25	20	29	50	50
28.2516 S	25	16	29	50	46
28.2512 S	25	12	29	50	46
28.2510 S	25	10	29	50	46
28.2508 S	25	08	29	50	46

Bohrer-Einsatzhülsen

Drill Insert Sleeves

Douille pour foret

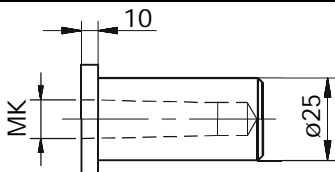

Nr. / No.	MK
QT 831	1
QT 832	2

Gewindeschneid-Schnellwechselfutter

Thread Cutting quick-change Chuck

Porte foret pour taraud à serrage rapide

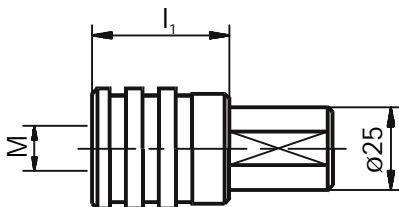

Nr. / No.	l_1	M
WFLK 1/25	41	M3 - M12
WFLK 2/25	64	M8 - M20

Pendelhalter

Floating Reamer Holder

Mandrins flottant

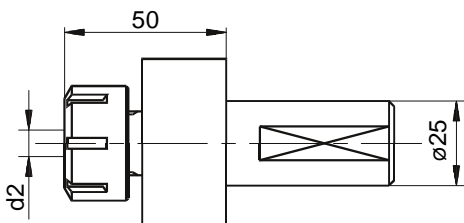

Nr. / No.	d_2	Spannzange / Collet / Pince
0250025	1 - 16	250 430 E

Kombihalter

Combi toolholder

Porte-outil combiné

Nr. / No.	l_1	l_2	d
17.3040 G300 (V)	90	123,5	40
17.3032 G300 (V)	90	115	32
17.3025 G300 (V)	90	115	25
17.3020 G300 (V)	90	115	20
17.3016 G300 (V)	90	115	16
17.3032 L G300 (V)	100	125	32

Mit V-Leisten,
bitte hinter Bestell-Nr. angeben,
z.B. 17.3040 G300 V

With V-plates,
please add V behind the part No.
for example 17.3040 G300 V

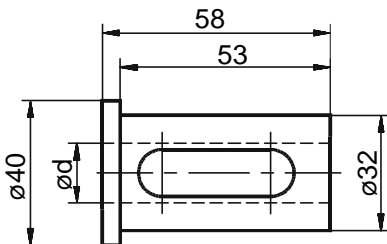

Nr. / No.	d
28.3206 G200	06
28.3208 G200	08
28.3210 G200	10
28.3212 G200	12
28.3216 G200	16
28.3220 G200	20
28.3225 G200	25
28.3225,4 G200	25,4 (1")

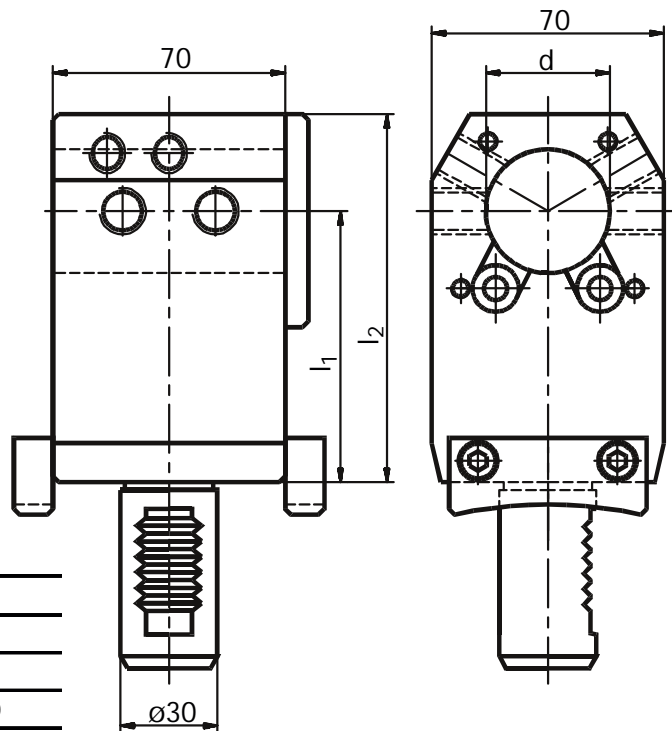

Weitere Abmessungen auf Anfrage.
Further dimensions on request.
Autre dimensions sur demande.

Für Haupt- und Gegenspindel
For main and subspindle
Pour broche principal et contre-broche

Ausdrehalter DIN 1835 E

Boring Tool Holder DIN 1835 E

Porte-outil d'alésage DIN 1835 E

Nr. / No.	d
27.3006 WN G300R (V)	6
27.3008 WN G300R (V)	8
27.3010 WN G300R (V)	10
27.3012 WN G300R (V)	12
27.3014 WN G300R (V)	14
27.3016 WN G300R (V)	16
27.3020 WN G300R (V)	20
27.3025 WN G300R (V)	25

Mit V-Leisten,
bitte hinter Bestell-Nr. angeben,
z.B. 27.3006 WN GR V

With V-plates,
please add V behind the part No.
for example 27.3006 WN GR V

RL: mit doppelverzahntem DIN-Schaft
with doubletoothed DIN shaft
universelle pour broche et contre-broche

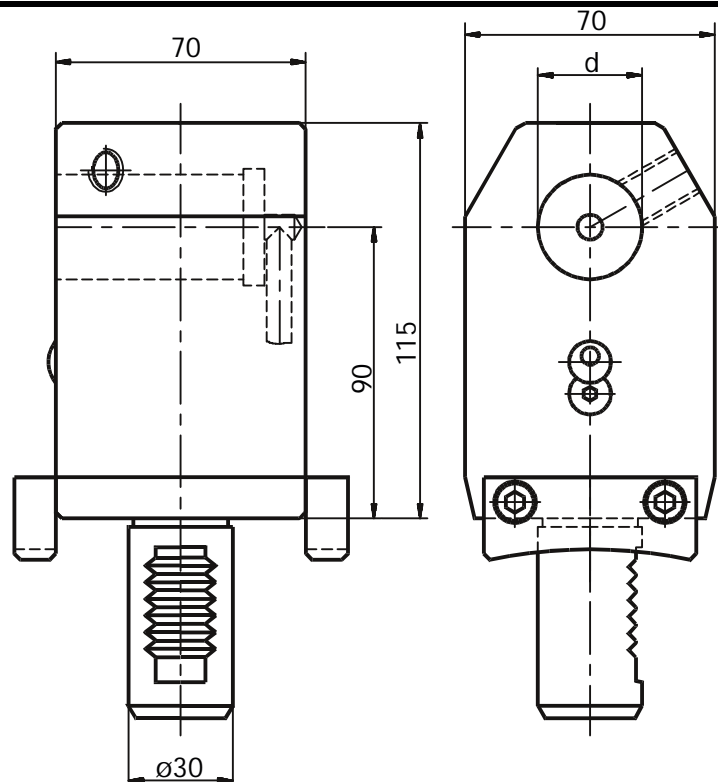

Ausdrehhalter mit Höhenverstellung

Boring Tool Holder with height adjustment

Porte-outil d'alésage avec hauteur réglable

Nr. / No.
220.1000 G300 R (V)
220.1000 G300 L (V)
220.1000 G300 RL (V)

Mit V-Leisten,
bitte hinter Bestell-Nr. angeben,
z.B. 17.3040 G300 V

With V-plates,
please add V behind the part No.
for example 17.3040 G300 V

- Ausführung R wie gezeichnet
right hand design as shown
à droite suivant croquis
- Ausführung L spiegelbildlich
left hand design reversed
à gauche inversé
- Ausführung RL mit doppelverzahntem DIN-Shaft
with doubletoothed DIN shaft
universelle pour broche et contre-broche

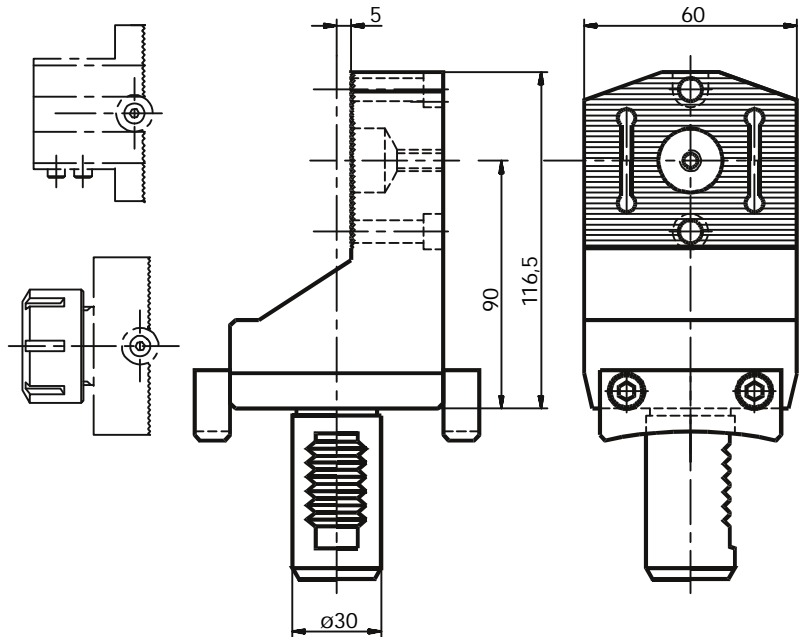

Ausdrehhaltestück Boring Tool Block Support d'alésage

Werkstoffanschlag Stock stop Porte-outil à buté de longueur

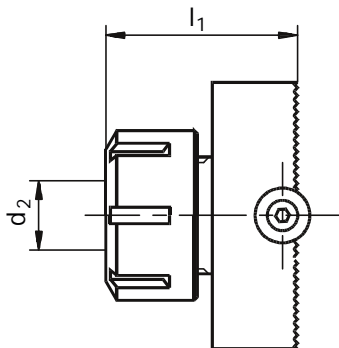

Nr. / No.	d ₂ Spannbereich d ₂ clamping range d, capacité	l ₁	Spannzange Collet Pince
20.650 220.1010	0,5 - 10	36	160 426 E
20.650 220.1020	1 - 16	41	25 430 E

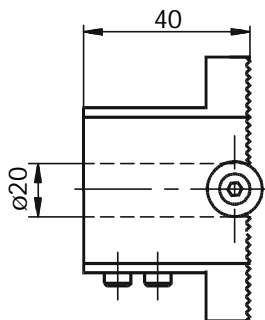

Nr. / No.
20.650
220.1030

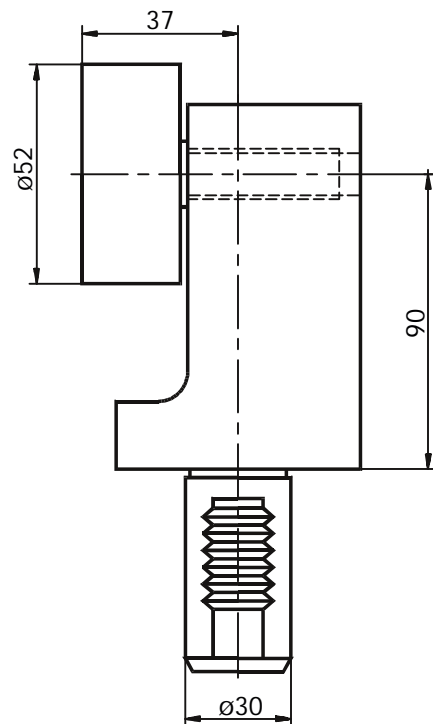

Nr. / No.	d
25.500 G300-26	26
25.500 G300-32	32
25.500 G300-42	42

Stechhalter mit Höheneinstellung

Infeed Tool Holder with height adjustment

Porte-outil de plongée à réglage vertical de centrage

Nr. / No.
310.0800 G300 R (V)
310.0900 G300 L (V)
310.G300 RL (V)

Mit V-Leisten, bitte hinter Bestell-Nr. angeben, z.B. 310.0800 G300 R V
 With V-plates, please add V behind the part No. for example 310.0800 G300 R V

- Ausführung R wie gezeichnet
right hand design as shown
à droite suivant croquis
- Ausführung L spiegelbildlich
left hand design reversed
à gauche inversé
- Ausführung RL mit doppelverzahntem DIN-Schaft
with doubletoothed DIN shaft
universelle pour broche et contre-broche

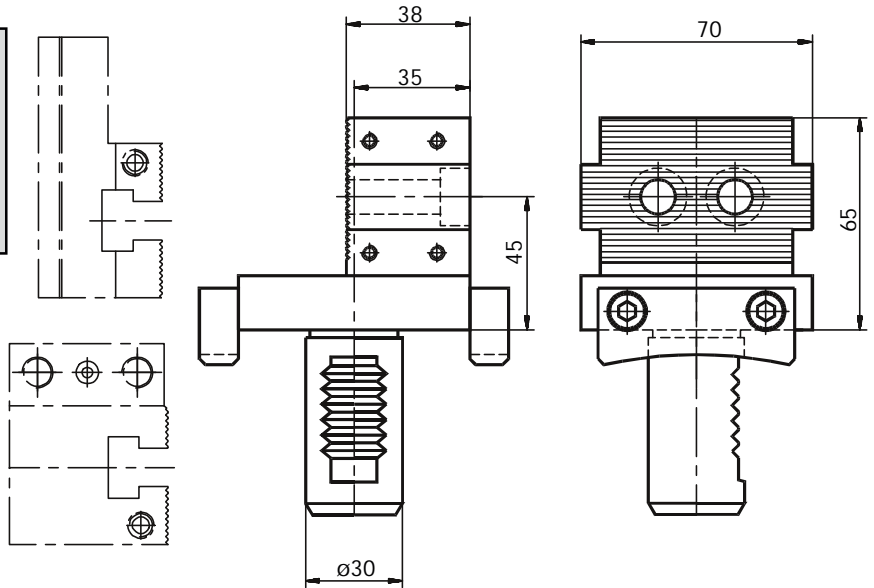

Stechhaltestück

Infeed Tool Block

Support outil de plongée

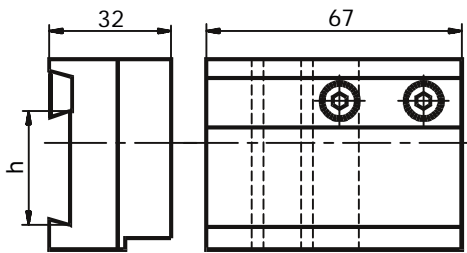

Nr. / No.	d
300.0980 R*	26
300.0981 R*	32
300.0980 L*	26
300.0981 L*	32

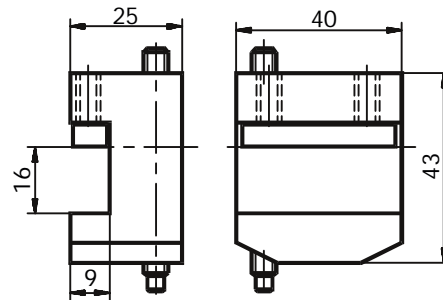

Nr. / No.
25.701
1661.10

*R wie gezeichnet / right hand design as shown / à droite suivant croquis
 L spiegelbildlich / left hand design reversed / à gauche inversé

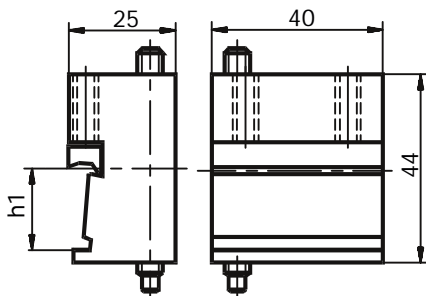

Nr. / No.	h ₁
25.704	16
1661.40	16
25.705	20
1661.70	20

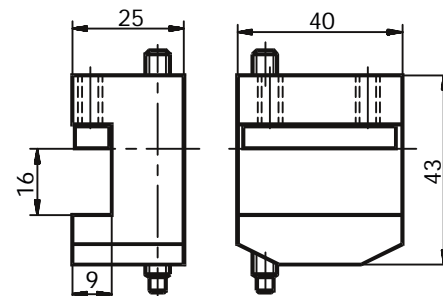

Nr. / No.
25.703
1661.30

Strehlhaltestück

Chaser Block

Support outil à fileter

Nr. / No.
230.0010

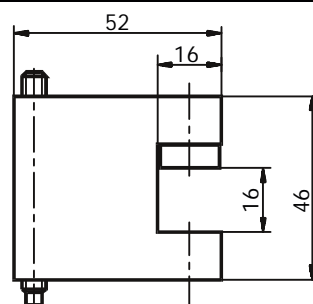
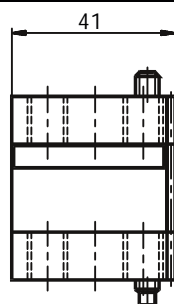

Drehhalter

Turning Tool Holder

Porte-outil de tournage

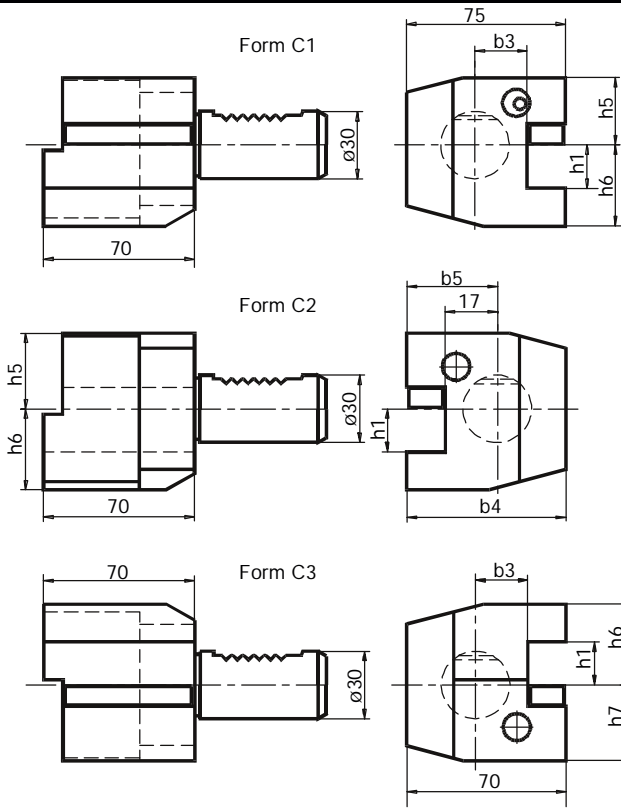

Nr. / No.	h_1	h_5	h_6	h_7	b_3	b_4	b_5
Form C1							
1.3020/16	20	28	38	--	17	--	--
1.3025 G300	25	34,5	46	--	17,2	--	--
Form C2							
4.3020/16	20	28	38	--	--	76	41
4.3025 G300	25	34,5	46	--	--	81	46
Form C3							
2.3020/16	20	--	38	35	17	--	--
2.3025 G300	25	--	46	34,5	17	--	--
Form C4							
3.3020/16	20	--	38	35	--	76	41
3.3025 G300	25	--	46	34,5	--	75	46

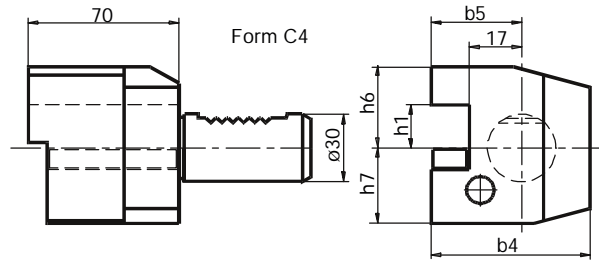

Vierkant

Turning tool radial

Porte-outil carré

Queraufnahme

Nr. / No.	
5.3025 G300	wie gezeichnet / as shown suivant croquis
6.3025 G300	spiegelbildlich / reversed inversé
5.3025 G300 RL	mit doppeltverzahntem DIN-Schaft with doubletoothed DIN shaft universelle pour broche et centre-broche

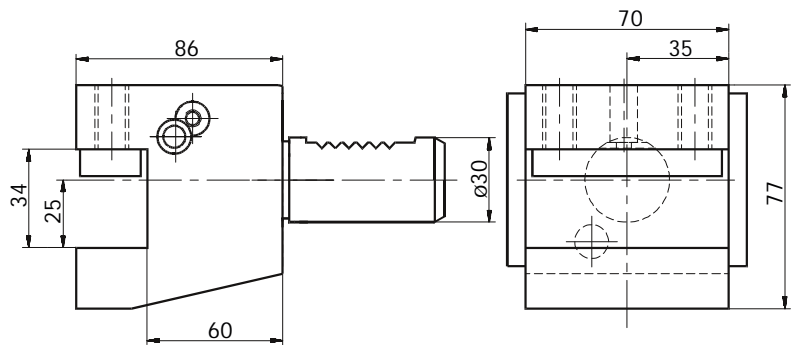

Doppel-Drehhalter

Double turning toolholder

Porte-outil double coté

Nr. / No.
15.3025 G300

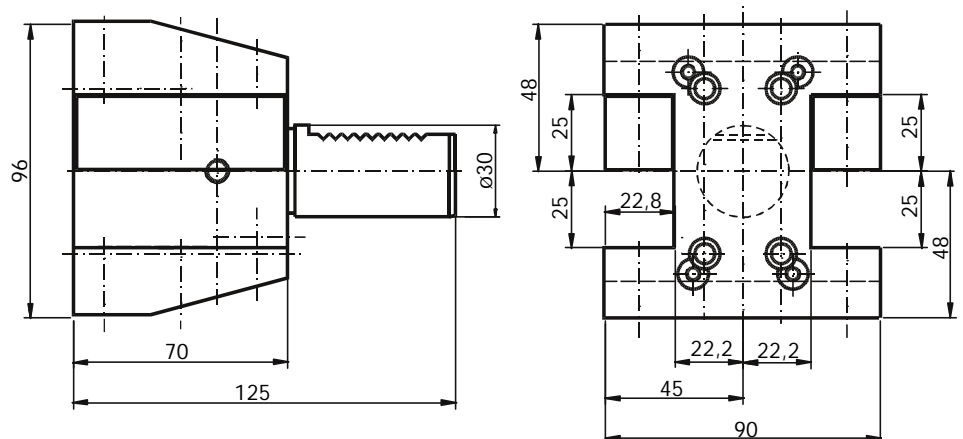

Axial Bohr- und Fräskopf

Axial drilling and milling head

Tête de perçage et fraisage

NEWS
i = 1:3

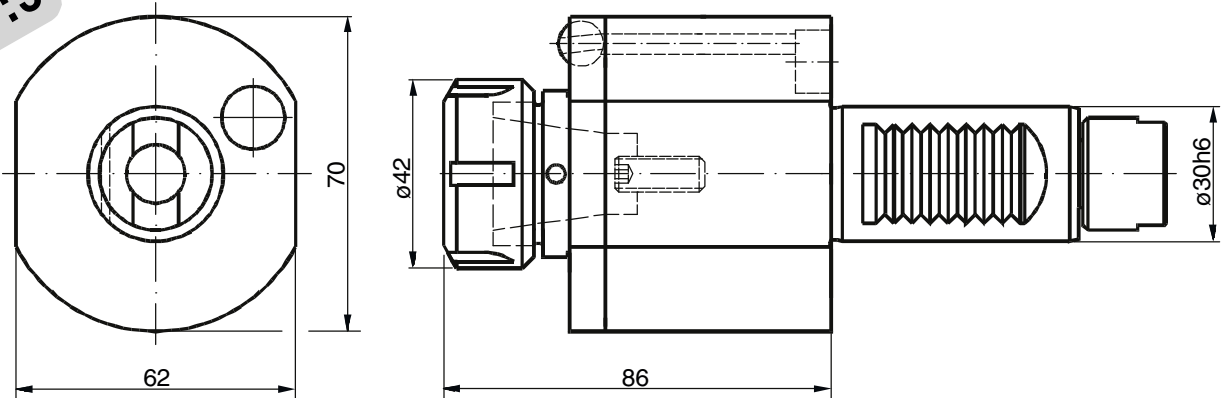

Innere Kühlmittelzufuhr. Zusatz IK an Bestellnummer anfügen.
Central cooling supply. Please add IK behind order no.

Bestell Nr. Order No.	i	n_{max} [1/min]	T_{max} [Nm]	Schlüsselsatz Wrench-set	Spannzange (siehe 1.27) Collet (see 1.27)
40.3025 G300	1:1	6000	25	225/HS40	RD/ER 25 430E (2-16)
40.3016 G300/13	1:3	18000	5	Abmessungen auf Anfrage Dimensions on request	

Axial Bohr- und Fräskopf

Axial drilling and milling head

Tête de perçage et fraisage

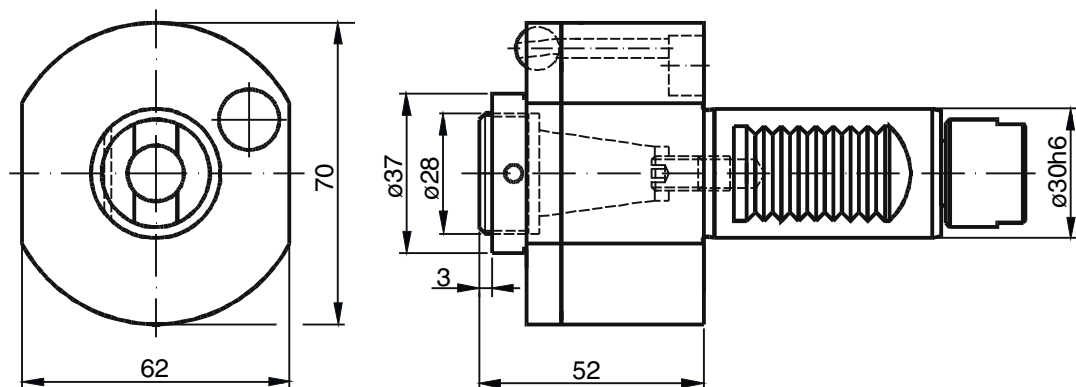

Innere Kühlmittelzufuhr. Zusatz IK an Bestellnummer anfügen.
Central cooling supply. Please add IK behind order no.

Bestell Nr. Order No.	i	n_{max} [1/min]	T_{max} [Nm]	Schlüsselsatz Wrench-set	Spannzange (siehe 1.27) Collet (see 1.27)
40.3020K G300	1:1	6000	20	LS20/HS40	RD/ER 20 428E (2-13)

Axial Bohr- und Fräskopf

Axial drilling and milling head

Tête de perçage et fraisage

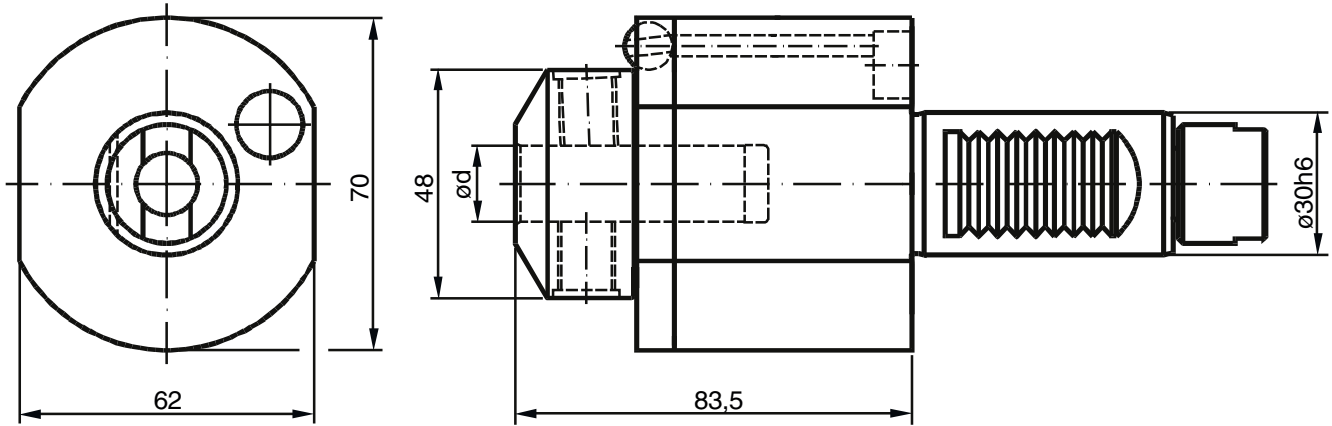

Innere Kühlmittelzufuhr. Zusatz IK an Bestellnummer anfügen.
Central cooling supply. Please add IK behind order no.

Bestell Nr. Order No.	d	i	n_{max} [1/min]	T_{max} [Nm]
40.3016 WN G300	16	1:1	6000	25
40.3020 WN G300	20	1:1	6000	25

Axial Bohr- und Fräskopf

Axial drilling and milling head

Tête de perçage et fraisage

NEWS
i = 1:2

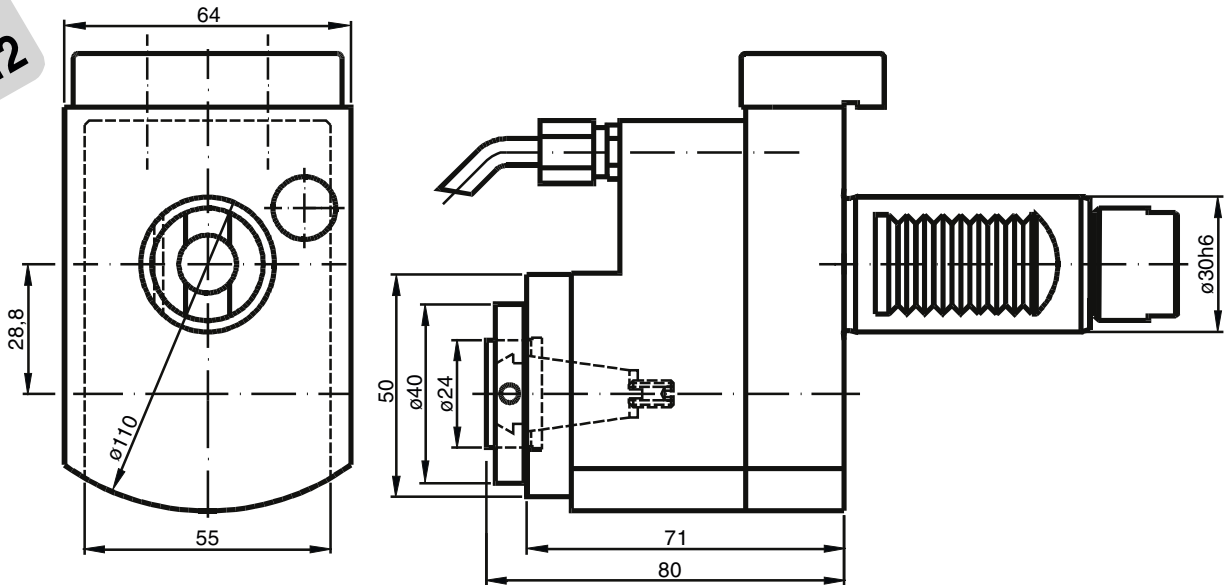

Innere Kühlmittelzufuhr. Zusatz IK an Bestellnummer anfügen.
Central cooling supply. Please add IK behind order no.

Bestell Nr. Order No.	i	n_{max} [1/min]	T_{max} [Nm]	Schlüsselsatz Key-set	Spannzange (siehe 1.27) Collet (see 1.27)
50.3016 G300/1	1:2	12000	8	LS16/HS40	RD/ER 16 426E (1-10)

Axial Gewindebohrkopf

Axial tapping head

Tête de taraudage

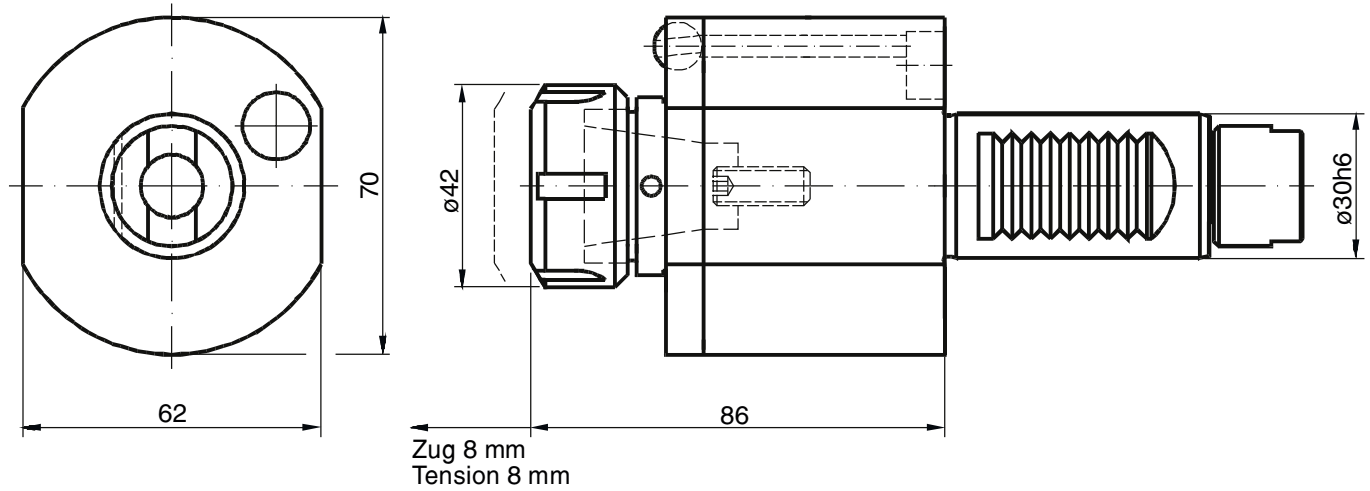

Bestell Nr. Order No.	i	n_{max} [1/min]	T_{max} [Nm]	Schlüsselsatz Key-set	Spannzange (siehe 1.27) Collet (see 1.27)
41.3025 G300	1:1	6000	16	225/GS22	RD/ER 25 430 E (2-16)

Radial Bohr- und Fräskopf

Radial drilling and milling head

Tête de perçage et fraisage radial

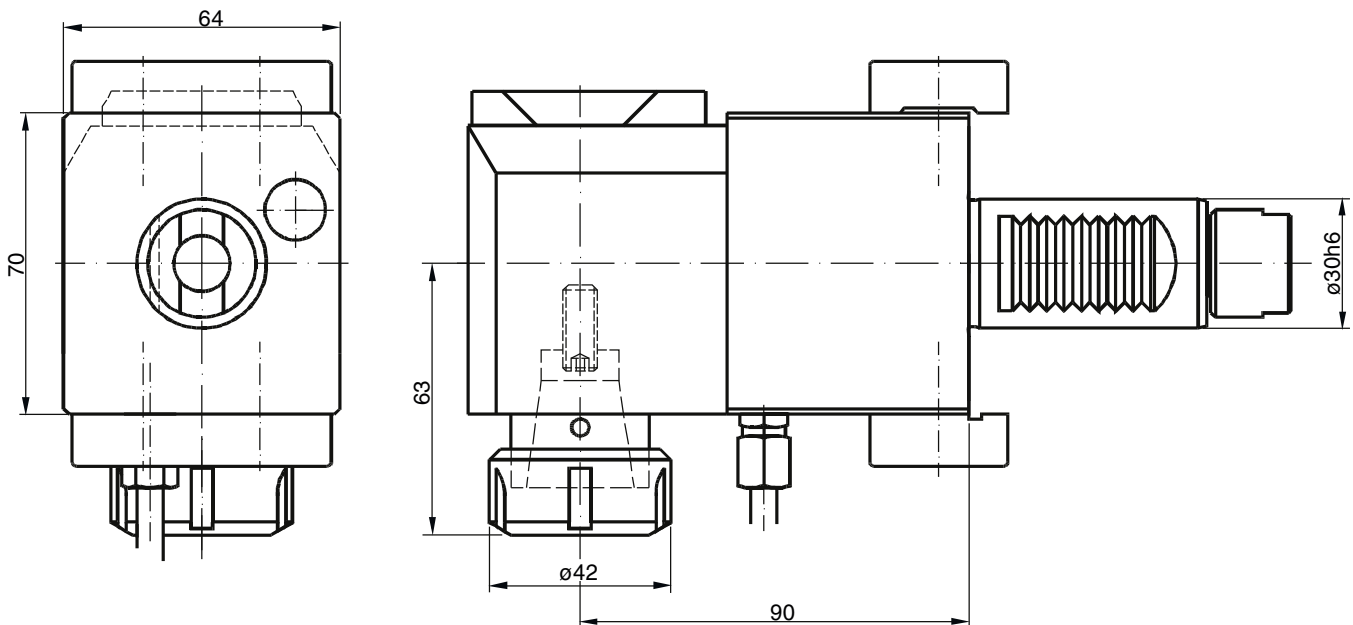

Innere Kühlmittelzufuhr. Zusatz IK an Bestellnummer anfügen.
Central cooling supply. Please add IK behind order no.

Mit V-Leiste, bitte V hinter Bestell-Nr. angeben,
z.B. 60.3025 G300 V
(Lizenz Index)

With V-plate, please add V behind the part No.
for ex. 60.3025 G300 V
(licence Index)

Bestell Nr. Order No.	i	n_{max} [1/min]	T_{max} [Nm]	Schlüsselsatz Key-set	Spannzange (siehe 1.27) Collet (see 1.27)
60.3025 G300 (V)	1:1	6000	25	225/HS40	RD/ER 25 430E (2-16)
60.3025 G300/2 (V)	2:1	6000	32	225/HS40	RD/ER 25 430E (2-16)

Radial Bohr- und Fräskopf

Radial drilling and milling head

Tête de perçage et fraisage radial

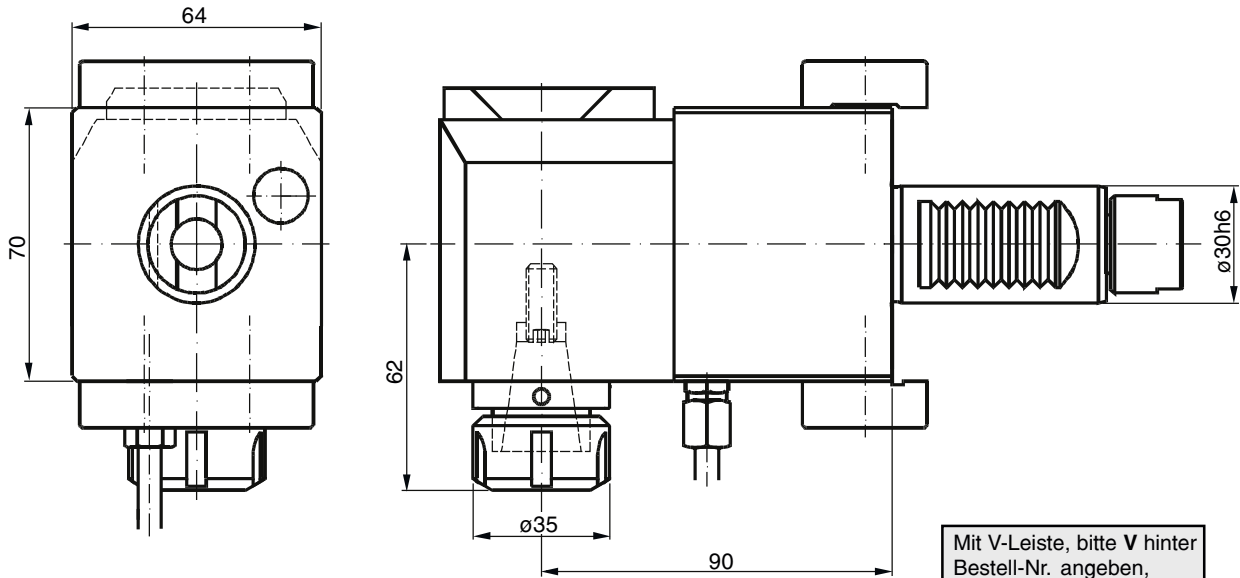

Innere Kühlmittelzufuhr. Zusatz IK an Bestellnummer anfügen.
Central cooling supply. Please add IK behind order no.

Bestell Nr. Order No.	i	n_{max} [1/min]	T_{max} [Nm]	Schlüsselsatz Key-set	Spannzange (siehe 1.27) Collet (see 1.27)
60.3020 G300/1 (V)	1:2	12000	12	GS25/HS40	RD/ER 20 428 E (1-13)

Mit V-Leiste, bitte V hinter Bestell-Nr. angeben, z.B. 60.3020 G300/1 V (Lizenz Index)
With V-plate, please add V behind the part No. for ex. 60.3020 G300/1 V (licence Index)

Radial Bohr- und Fräskopf

Radial drilling and milling head

Tête de perçage et fraisage radial

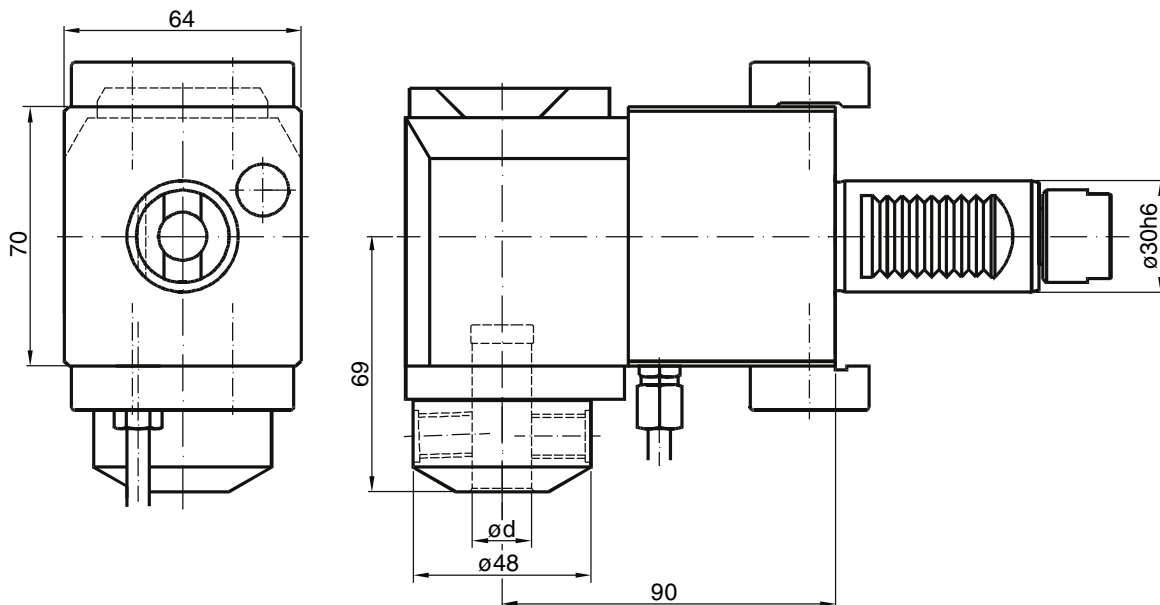

Innere Kühlmittelzufuhr. Zusatz IK an Bestellnummer anfügen.
Central cooling supply. Please add IK behind order no.

Bestell Nr. Order No.	d	i	n_{max} [1/min]	T_{max} [Nm]
60.3016 WN G300 (V)	16	1:1	6000	25
60.3016 WN G300/2 (V)	16	2:1	6000	32
60.3020 WN G300/2 (V)	20	2:1	6000	32

Mit V-Leiste, bitte V hinter Bestell-Nr. angeben, z.B. 60.3016 WN G300 V (Lizenz Index)
With V-plate, please add V behind the part No. for ex. 60.3016 WN G300 V (licence Index)

**Radial
Gewindebohrkopf**

**Axial
tapping head**

**Tête de
taroudage radial**

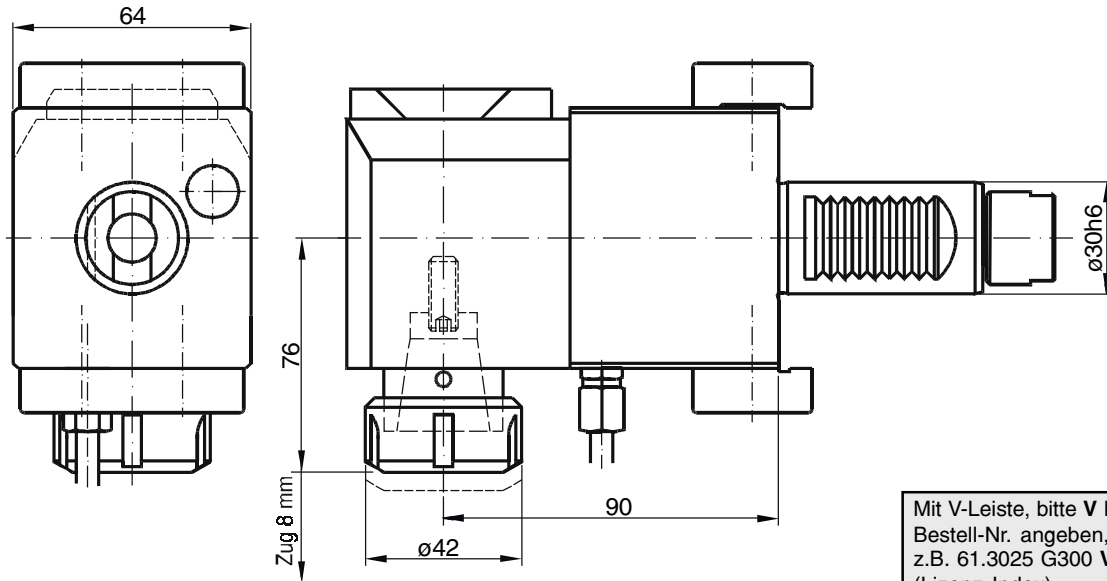

Mit V-Leiste, bitte **V** hinter Bestell-Nr. angeben, z.B. 61.3025 G300 **V** (Lizenz Index)
With V-plate, please add **V** behind the part No. for ex. 61.3025 G300 **V** (licence Index)

Bestell Nr. Order No.	i	n_{max} [1/min]	T_{max} [Nm]	Schlüsselsatz Key-set	Spannzange (siehe 1.27) Collet (see 1.27)
61.3025 G300 (V)	1:1	6000	25	225/GS22	RD/ER 25 430 E (2-16)

**Radial
Fräskopf**

**Radial
milling head**

**Tête de
fraisage radial**

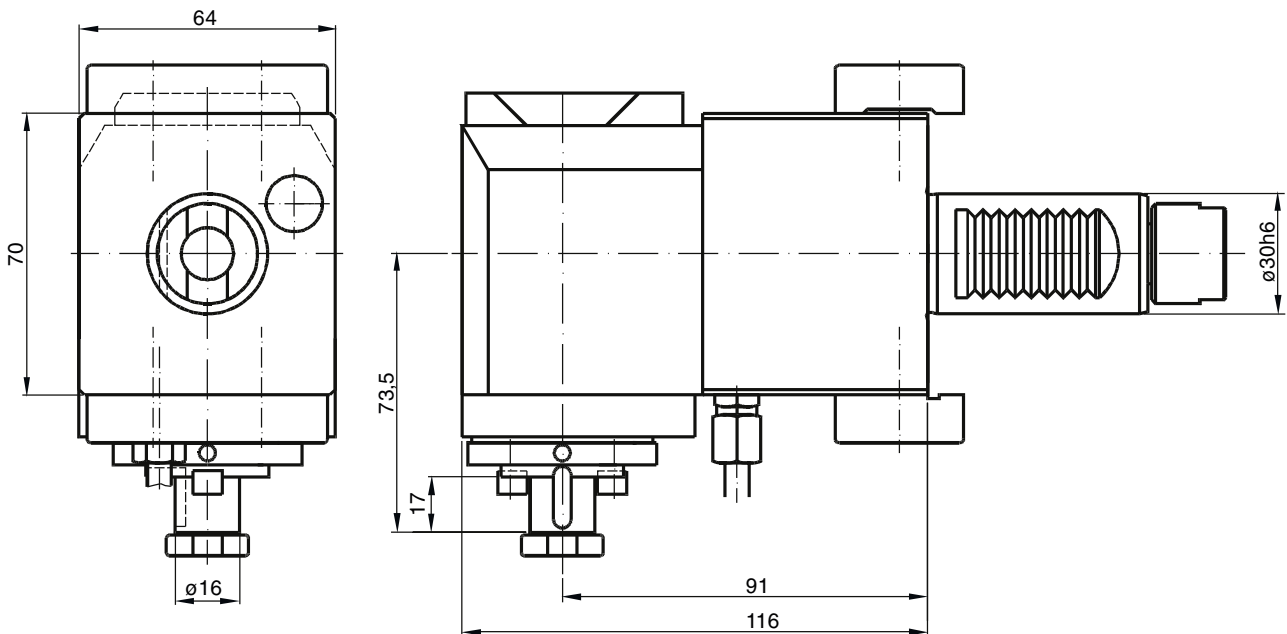

Andere ø verfügbar
Other ø available
Autre ø possible

Bestell Nr. Order No.	i	n_{max} [1/min]	T_{max} [Nm]
62.3016 G300 (V)	1:1	6000	25
62.3016 G300/2 (V)	2:1	6000	32

Mit V-Leiste, bitte **V** hinter Bestell-Nr. angeben, z.B. 62.3016 G300 **V** (Lizenz Index)
With V-plate, please add **V** behind the part No. for ex. 62.3016 G300 **V** (licence Index)

Radial Bohr- und Fräskopf ±105° schwenkbar

Radial drilling and milling
head swivel ±105°

Tête de perçage et
fraisage pivotante ±105°

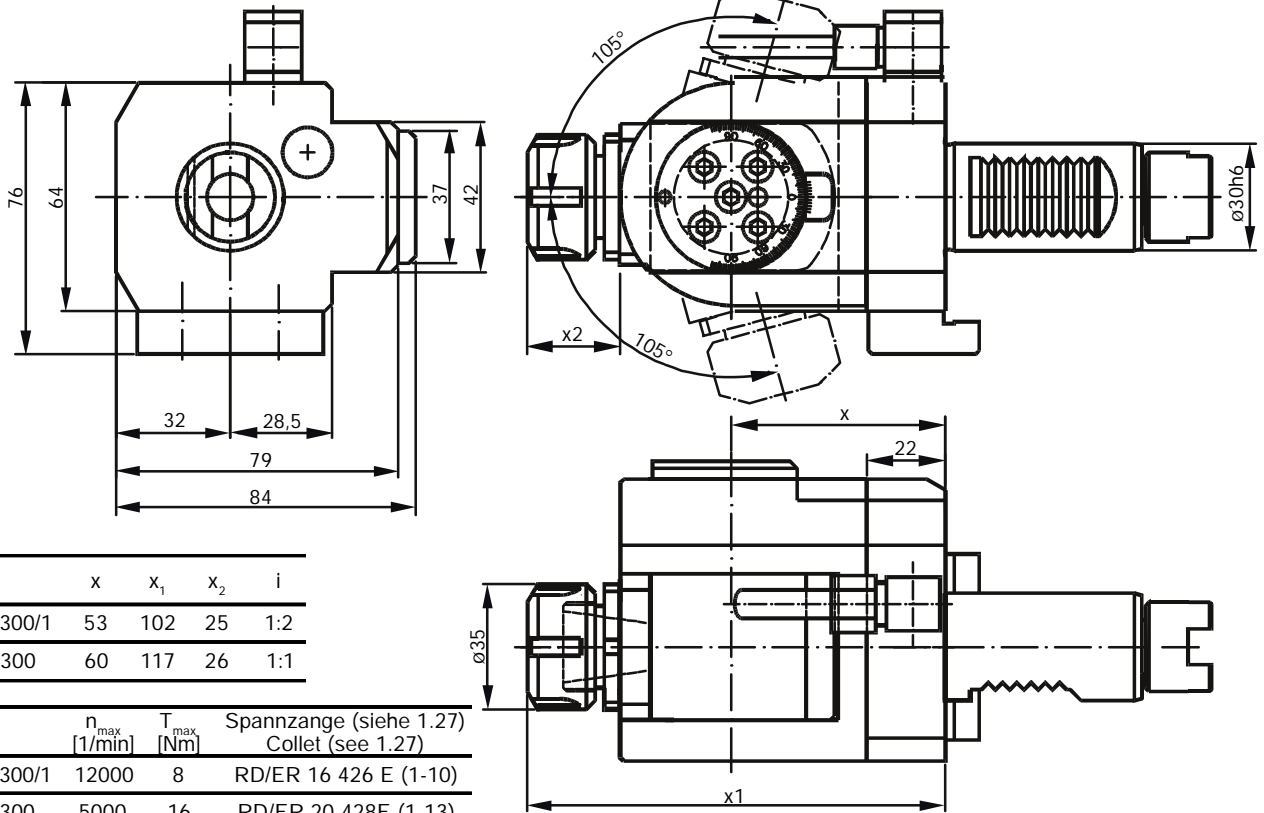

Bestell Nr. Order No.	x	x ₁	x ₂	i
63.3016 G300/1	53	102	25	1:2
63.3020 G300	60	117	26	1:1

Bestell Nr. Order No.	n _{max} [1/min]	T _{max} [Nm]	Spannzange (siehe 1.27) Collet (see 1.27)
63.3016 G300/1	12000	8	RD/ER 16 426 E (1-10)
63.3020 G300	5000	16	RD/ER 20 428E (1-13)

Radial Scheibenkopf

Radial drilling head
for side milling cutters

Tête de fraisage radial
pour fraise scie

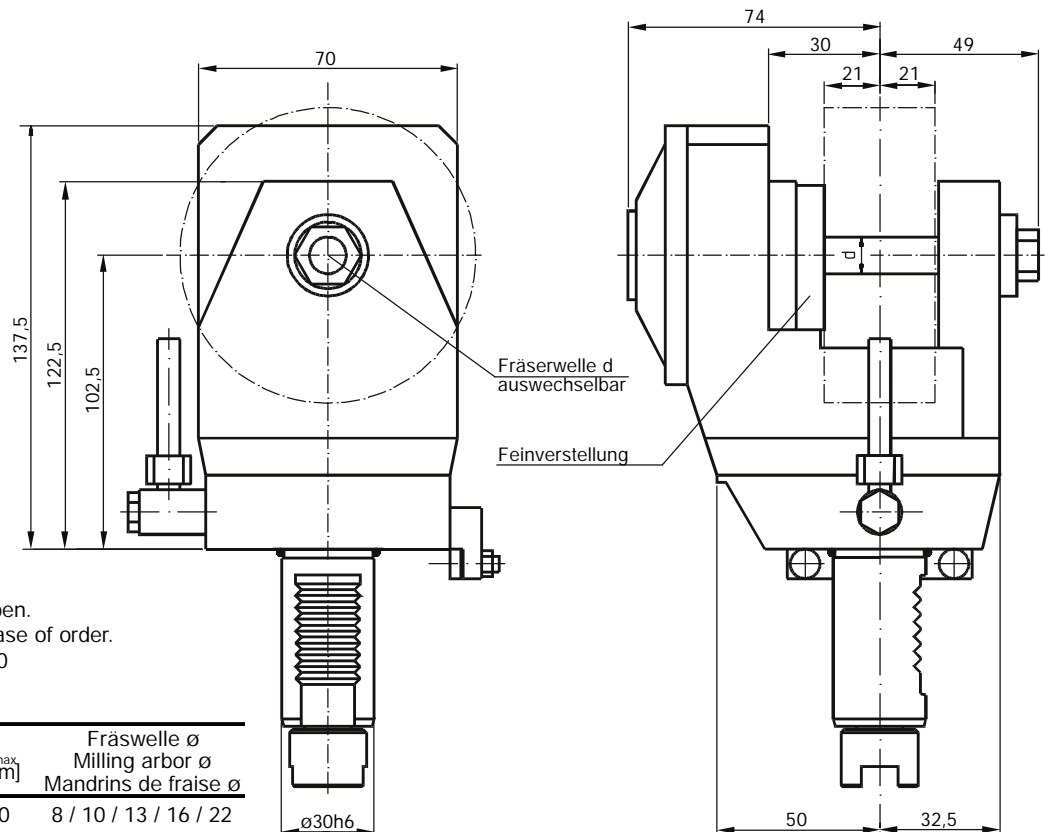

Fräserwelle ø bei Bestellung angeben.
Milling arbor ø please inform in case of order.
Beispiel / Example: 64.3016 G300

Bestell Nr. Order No.	i	n _{max} [1/min]	T _{max} [Nm]	Fräserwelle ø Milling arbor ø Mandrins de fraise ø
64.30.. G300	2,55:1	2000	40	8 / 10 / 13 / 16 / 22

**Axial Bohr-
und Fräskopf
y-verstellbar**

**Axial drilling and
milling head
y-axis adjustable**

**Tête de perçage
et fraisage
y-axis adjustable**

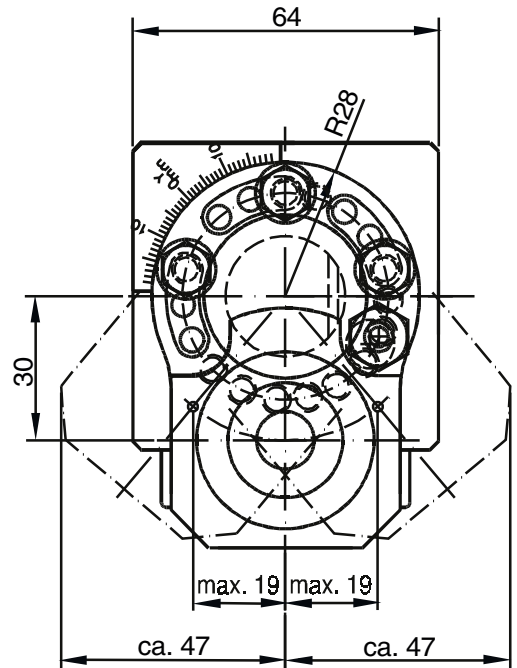
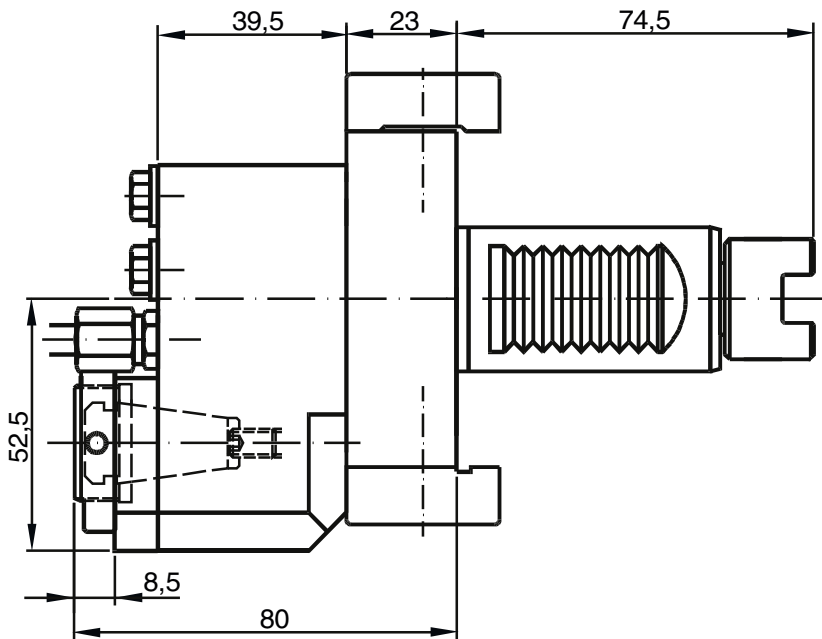

Bestell Nr. Order No.	i	n_{max} [1/min]	T_{max} [Nm]	Spannzange (siehe 1.27) Collet (see 1.27)
56.3016 G300	1:1	5000	16	RD/ER 16 426 E (1-20)

**Axial Bohr-
und Fräskopf**

**Axial drilling and
milling head**

**Tête de fraisage radial
pour fraise scie**

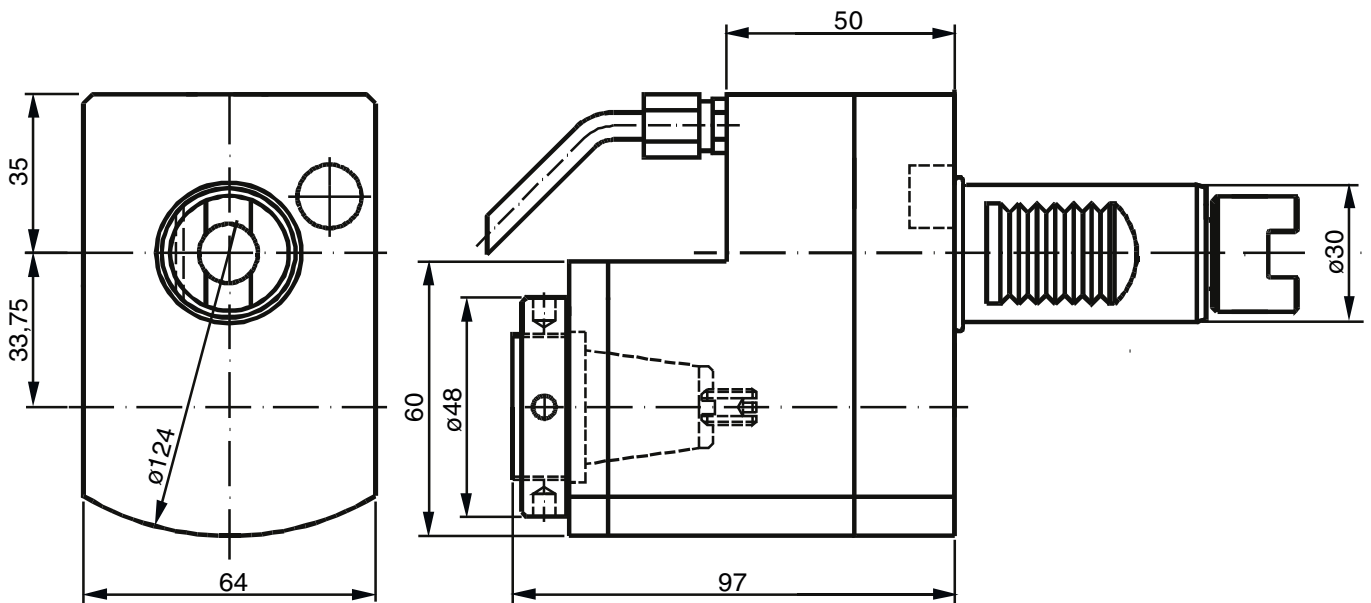

Bestell Nr. Order No.	i	n_{max} [1/min]	T_{max} [Nm]	Spannzange (siehe 1.27) Collet (see 1.27)
50.3025 G300/2	2:1	3000	40	RD/ER 25 430 E (2-16)



Statische- und angetriebene Werkzeuge Schaft Ø30 für:

*Static and driven tools shank Ø30 for:
Porte-outils statiques et motorisés VDI30 pour:*

Traub TNC42, TNC65

Bohrhalter

Drill holder

Porte-foret

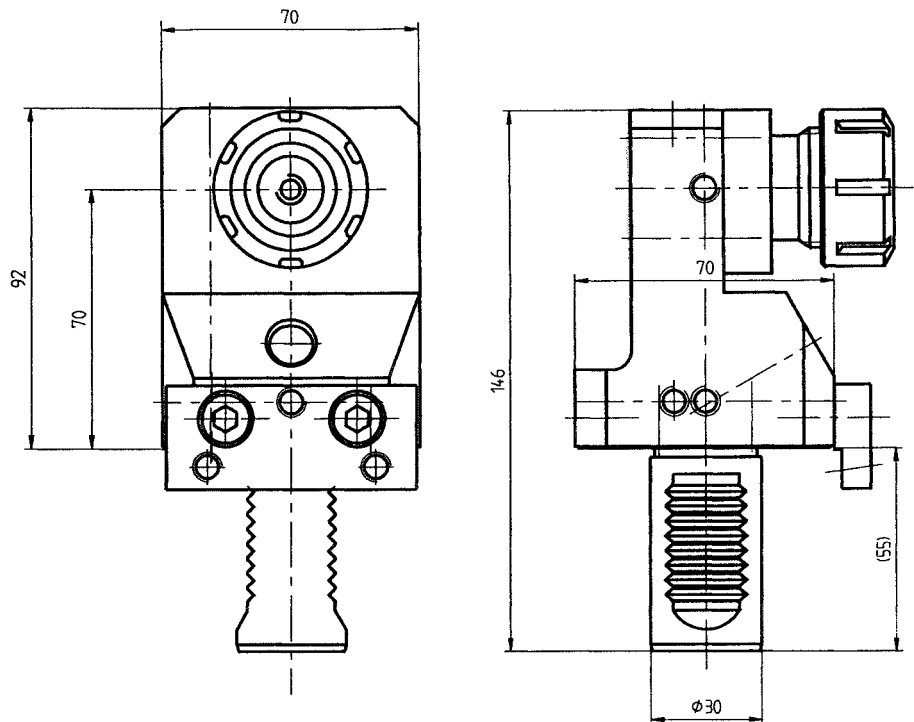

Bestell Nr. Order No.	d ₂	l ₁	l ₂	Spannzange (siehe S. 1.27) Collet / Pince (see page 1.27)
31.3025TNC65	2-16	52,5	72,5	250 430 E
31.3032TNC65	3-20	55,5	75,5	320 470 E

4

Bohrhalter

Drill holder

Porte-foret

Bestell Nr. Order No.	d
27.3032TNC65	32
27.3025TNC65	25
27.3020TNC65	20

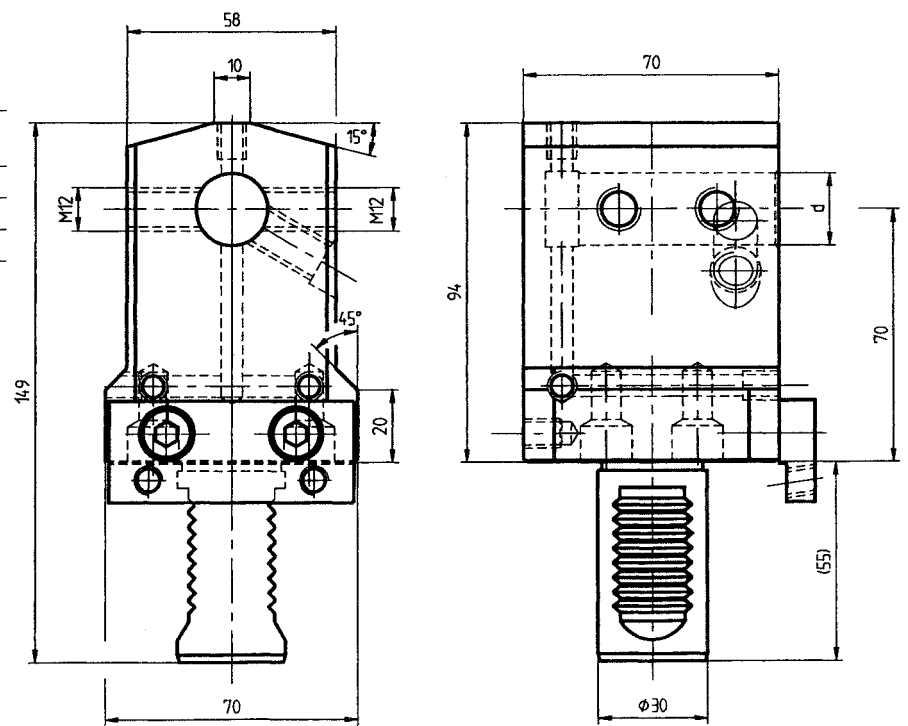

Kombihalter

Combi toolholder

Porte-outil combiné

Bestell Nr. Order No.	d
17.3032TNC65	32
17.3025TNC65	25
17.3020TNC65	20
17.3016TNC65	16

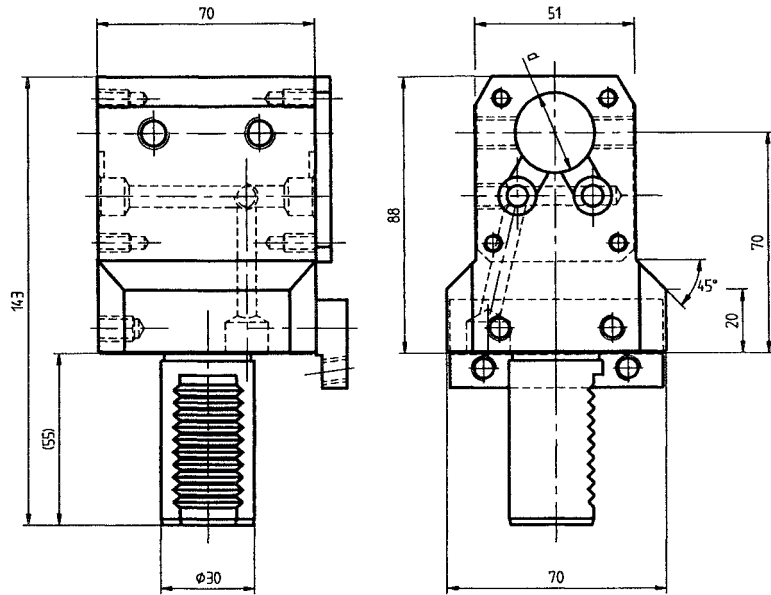

Aufnahmehülsen

Adaptor sleeve

Douille de reduction

Bestell Nr. Order No.	d ₁	d ₂	d ₃	l ₁	l ₂
28.3225G200	32	25	40	63	58
28.3220G200	32	20	40	63	58
28.3216G200	32	16	40	63	58
28.3212G200	32	12	40	63	58
28.3210G200	32	10	40	63	58
28.3208G200	32	08	40	63	58

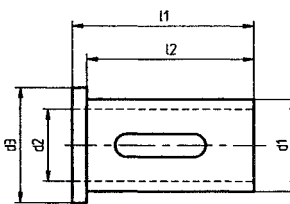

Bestell Nr. Order No.	d ₁	d ₂	d ₃	l ₁	l ₂
28.2520S	25	20	29	50	46
28.2516S	25	16	29	50	46
28.2512S	25	12	29	50	46
28.2510S	25	10	29	50	46
28.2508S	25	08	29	50	46

Bohrer-Einsatzhülsen

Drill Insert Sleeves

Douille pour foret

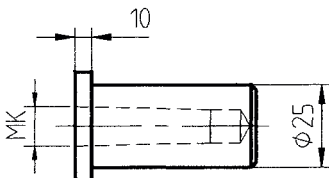

Nr. / No.	MK
QT831	1
QT832	2

Gewindeschneid-Schnellwechselfutter

Thread Cutting quick-change Chuck

Porte foret pour taraud à serrage rapide

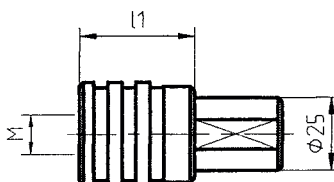

Nr. / No.	l ₁	M
WFLK1/25	41	M3 - M12
WFLK2/25	64	M8 - M20

Pendelhalter

Floating Reamer Holder

Mandrins flottant

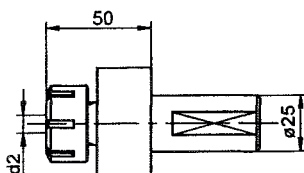

Nr. / No.	d ₂	Spannzange/Collet/Pince
0250025	1 - 16	250 430E

Abstechhalter

mit linearer Höheneinstellung

Infeed toolholder

with linear height adjustment

Porte-outil

de plongée à réglage vertical de centrage

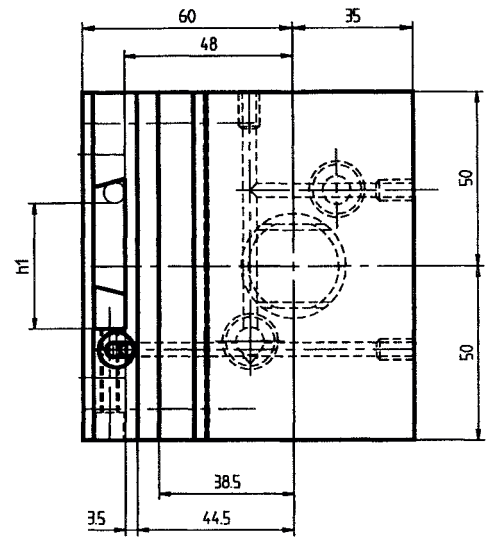
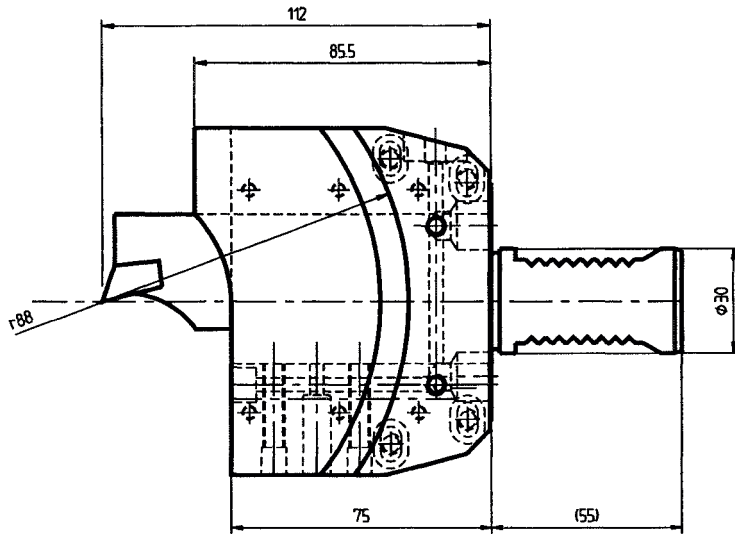

Bestell Nr. Order No.	h_1
32.3032TNC65	32
32.3026TNC65	26

Werkstoffanschlag

Stock stop

Porte-outil à buté de longueur

Nr. / No.	ϕd
25.500TNC65-26	26
25.500TNC65-32	32
25.500TNC65-42	42

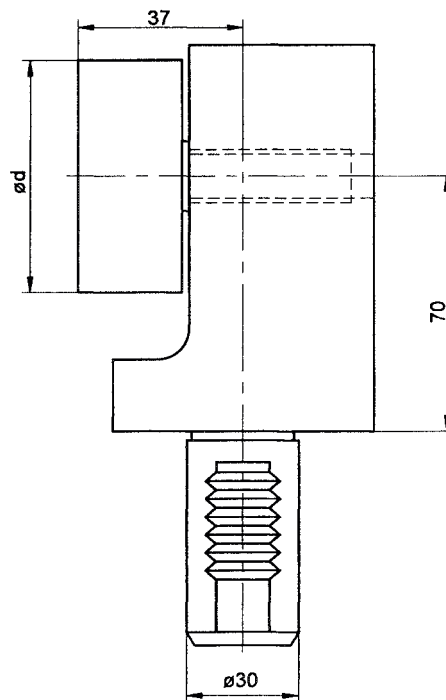

Drehhalter

Turning tool holder

Porte-outil de tournage

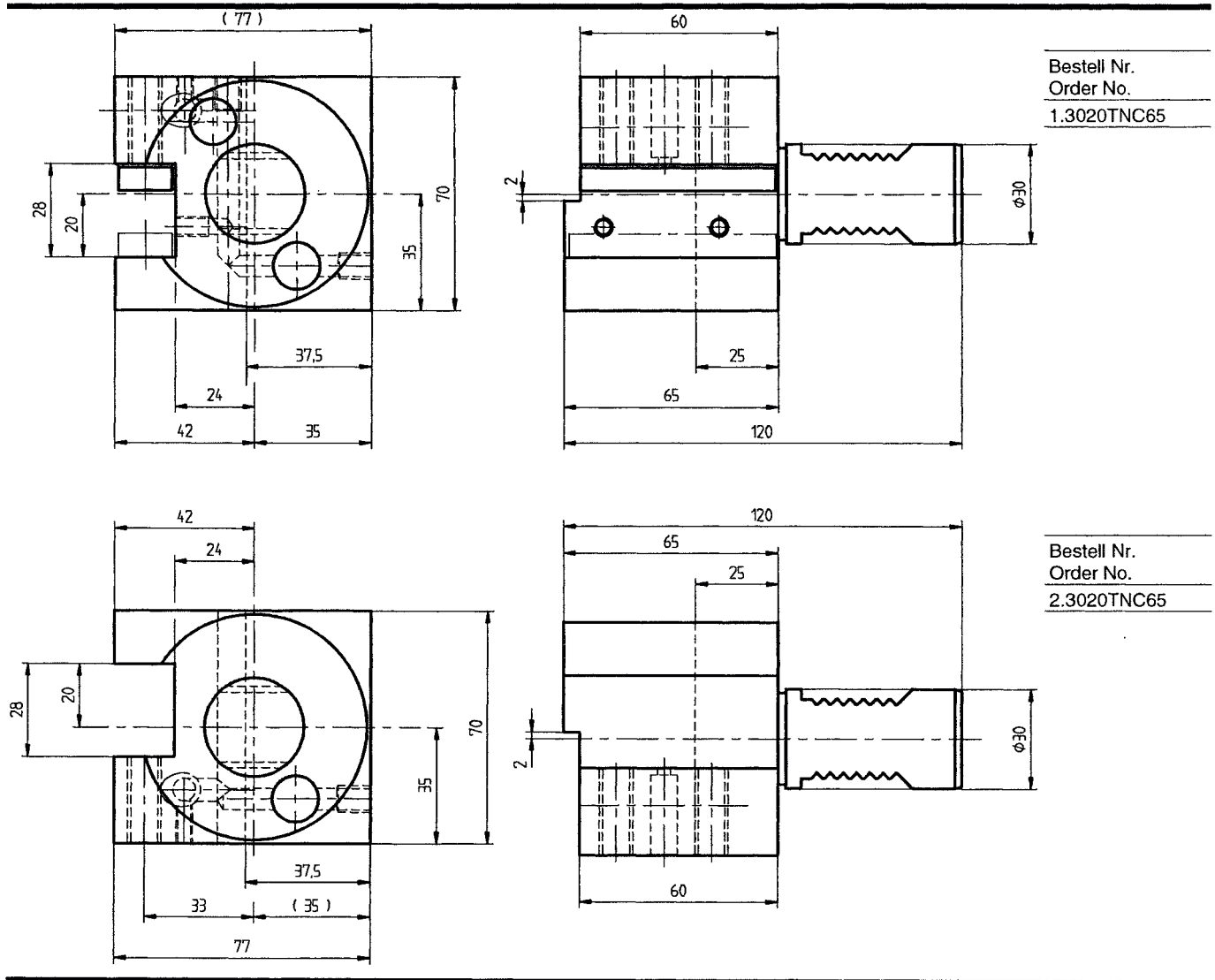

**Vierkant
Queraufnahme**

**Turning tool
radial**

**Radial-porte-outil
carré**

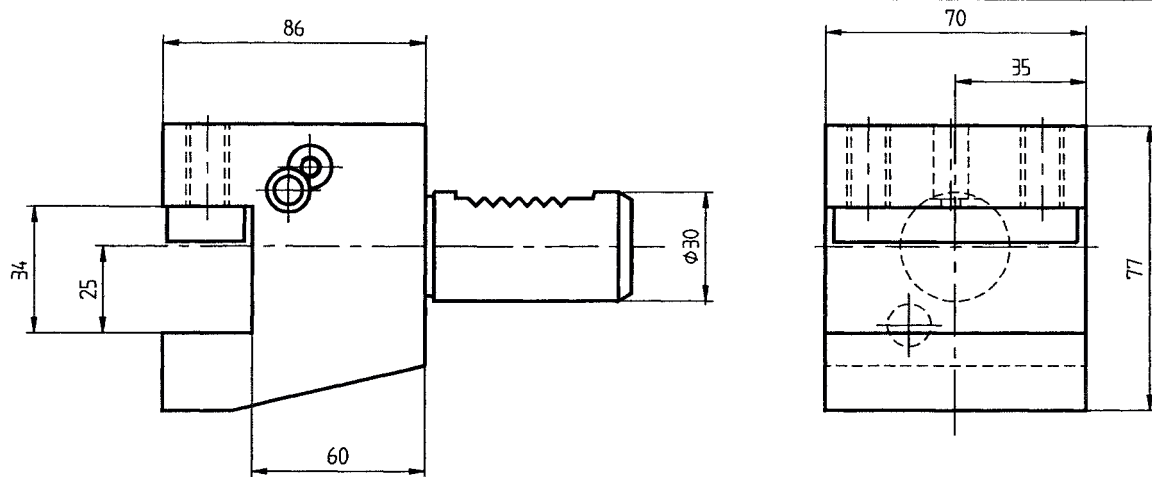

Nr. / No.	
5.3025G300	wie gezeichnet / as shown / suivant croquis
6.3025G300	spiegelbildlich / reversed / inversé
5.3025G300RL	mit doppelverzahntem DIN-Schaft / with doubletoothed DIN shaft / universelle pour broche et contre-broche

**Axial Bohr-
und Fräskopf**

**Axial drilling and
milling head**

**Tête de perçage
et fraisage**

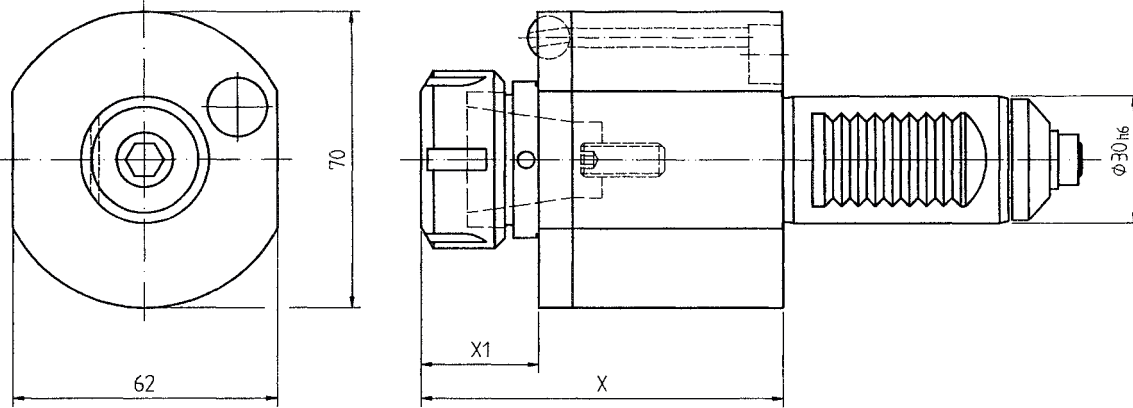

Bestell Nr. Order No.	i	x	x1	n _{max} [1/min]	T _{max} [Nm]	Schlüsselsatz Key-set	Spannzange (siehe 1.27) Collet (see 1.27)
40.3025TNC65	1:1	86	28	6000	16	225/HS40	RD/ER 25 430E (2-16)
40.3025TNC65K	1:1	69	28	6000	16	225/HS40	RD/ER 25 430E (2-16)

**Axial Bohr-
und Fräskopf**

**Axial drilling and
milling head**

**Tête de perçage
et fraisage**

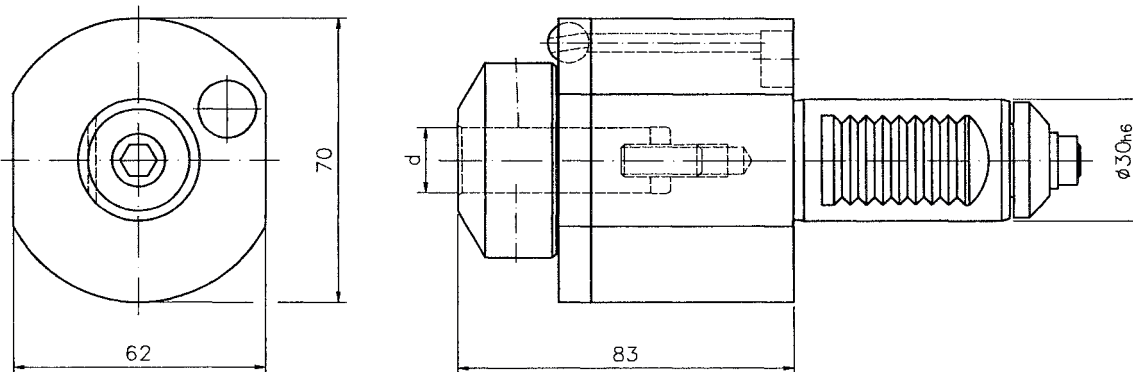

Bestell Nr. Order No.	i	d	n _{max} [1/min]	T _{max} [Nm]
40.3016WNTNC65	1:1	16	6000	16

Axial Bohr- und Fräskopf

Axial drilling and milling head

Tête de perçage et fraiseage

**Neu
new
i = 1:2**

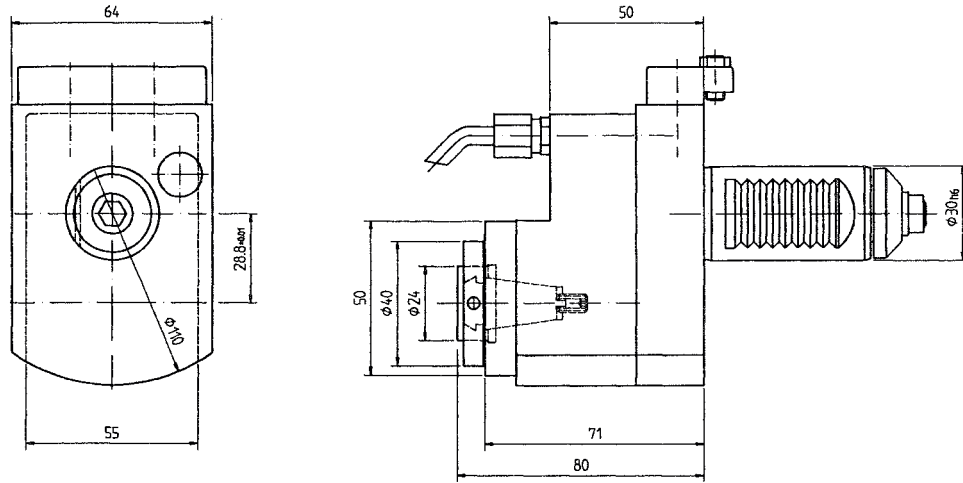

Innere Kühlmittelzufuhr: Zusatz IK an Bestellnummer anfügen
Central cooling supply: Please add IK behind order no.

Bestell Nr. Order No.	i	n_{max} [1/min]	T_{max} [Nm]	Schlüsselsatz Key-set	Spannzange (siehe 1.29) Collet (see 1.29)
40.3016ATNC65/1	1:2	12000	8	LS16/HS40	RD/ER 16 426E (1-16)

Axial Bohr- und Fräskopf

Axial drilling and milling head

Tête de perçage et fraiseage

**Neu
new
i = 1:3**

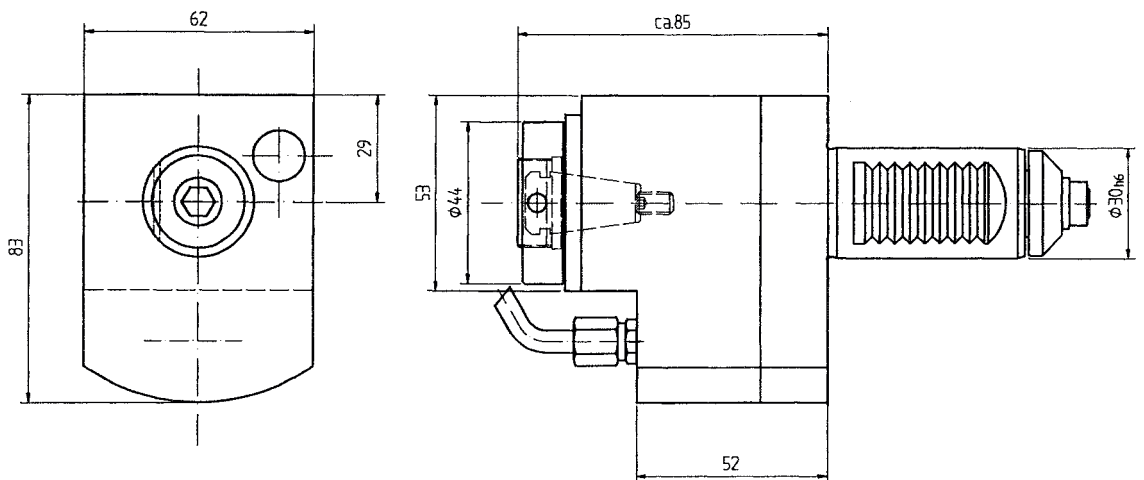

Innere Kühlmittelzufuhr: Zusatz IK an Bestellnummer anfügen
Central cooling supply: Please add IK behind order no.

Bestell Nr. Order No.	i	n_{max} [1/min]	T_{max} [Nm]	Schlüsselsatz Key-set	Spannzange (siehe 1.29) Collet (see 1.29)
40.3016TNC65/13	1:3	18000	8	LS16/HS40	RD/ER 16 426E (1-10)

**Radial Bohr-
und Fräskopf**

**Radial drilling
and milling head**

**Tête de perçage et
fraisage radial**

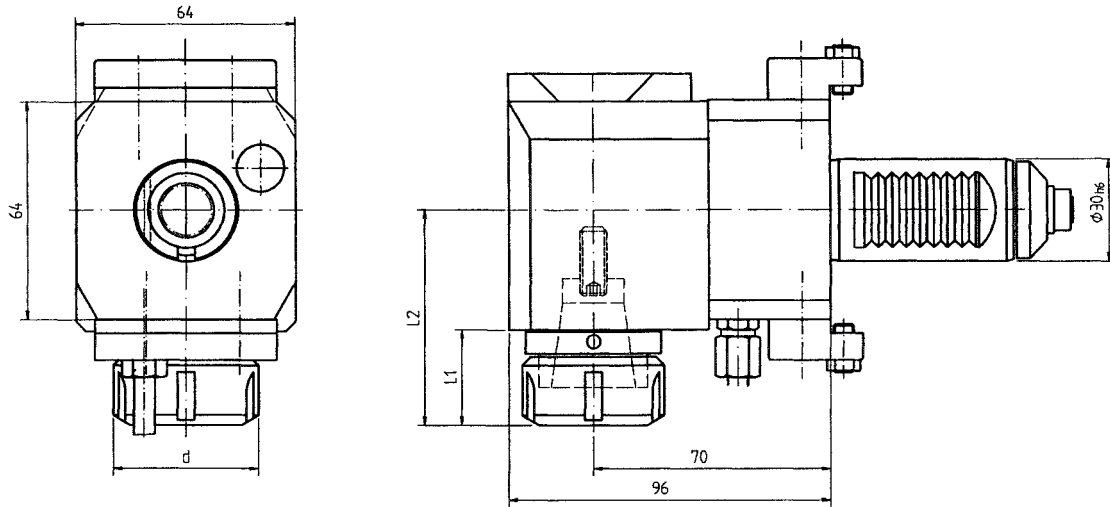

Bestell Nr. Order No.	i	d	n _{max} [1/min]	T _{max} [Nm]	Schlüsselsatz Key-set	Spannzange (siehe 1.29) Collet (see 1.29)
60.3020TNC65	1:1	35	6000	25	GS30/HS40	200 428 E / ET1-20
60.3025TNC65	1:1	42	6000	25	225/HS40	250 430 E / ET1-25
60.3020TNC65/1	1:2	35	12000	16	GS30/HS40	200 428 E / ET1-20
60.3016TNC65/13	1:3	28	18000	8	GS25/HS40	160 426 E / ET1-10
60.3020TNC65/2	2:1	42	6000	32	225/HS40	250 430 E / ET1-25
60.3025TNC65/2	2:1	35	6000	32	GS30/HS40	200 428 E / ET1-20

4

**Radial Bohr-
und Fräskopf**

**Radial drilling
and milling head**

**Tête de perçage et
fraisage radial**

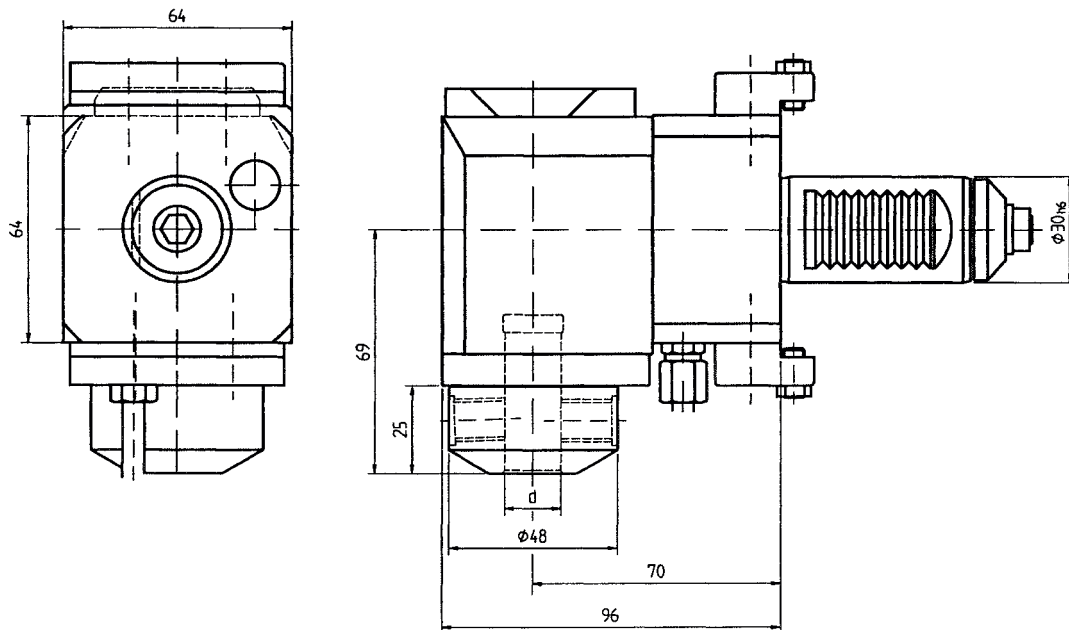

Bestell Nr. Order No.	i	n _{max} [1/min]	T _{max} [Nm]	d [mm]
60.3016WNTNC65	1:1	6000	25	16
60.3016WNTNC65/2	2:1	6000	32	16
60.3020WNTNC65	1:1	6000	25	20
60.3020WNTNC65/2	2:1	6000	32	20

Radial Bohr- und Fräskopf

Radial drilling and milling head

Tête de perçage et fraisage radial

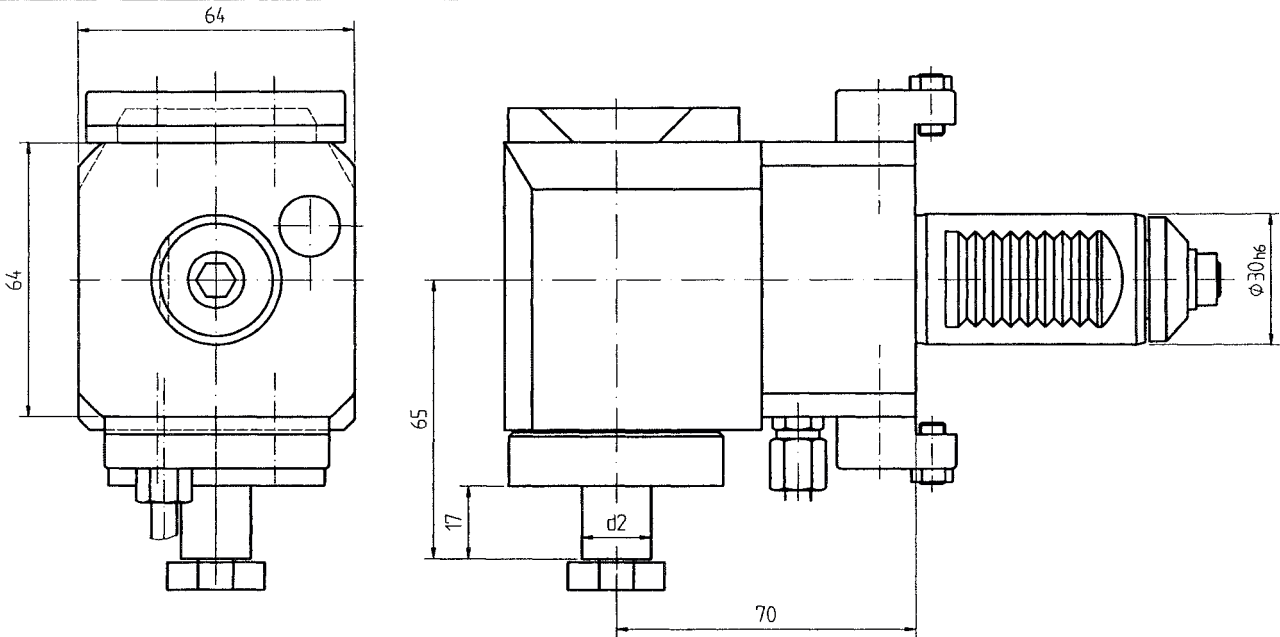

Bestell Nr. Order No.	i	d	n _{max} [1/min]	T _{max} [Nm]
62.3016TNC65	1:1	16	6000	25
62.3022TNC65	1:1	22	6000	25
62.3016TNC65/2	2:1	16	6000	32
62.3022TNC65/2	2:1	22	6000	32
62.3027TNC65/2	2:1	27	6000	32

Schwenkkopf ± 105°

Swivel head ± 105°

Tête pivotante ± 105°

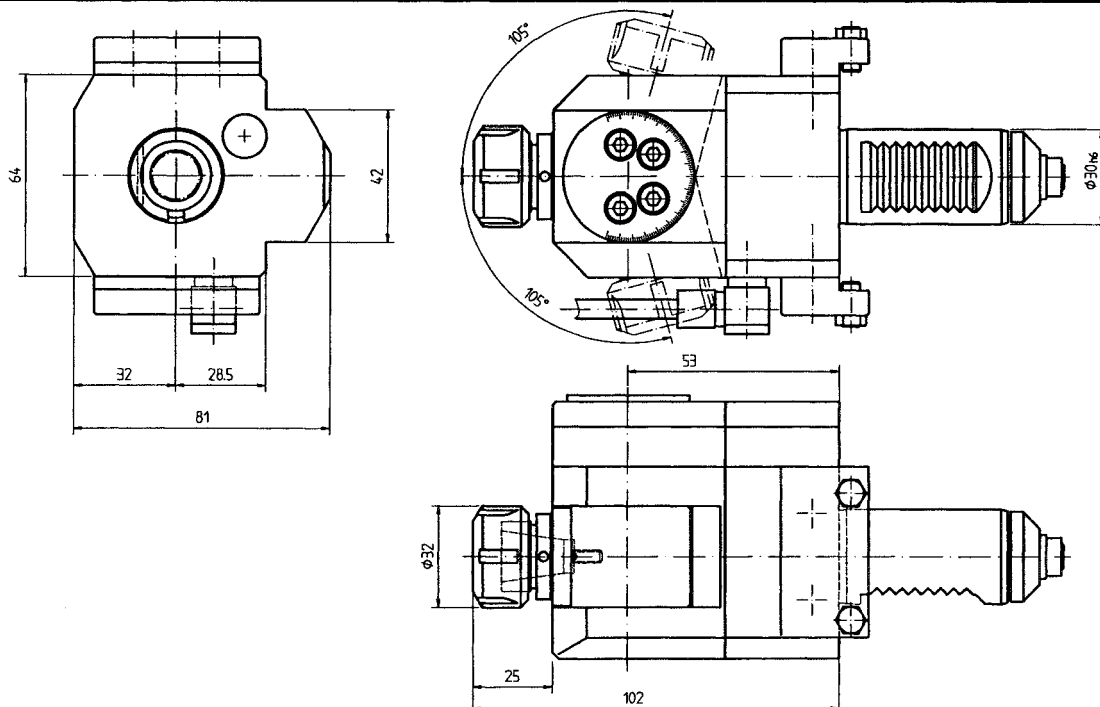

Bestell Nr. Order No.	i	n _{max} [1/min]	T _{max} [Nm]	Schlüsselsatz Key-set	Spannzange (siehe 1.29) Collet (see 1.29)
63.3016TNC65/1	1:2	9000	16	GS25/HS28	RD/ER 16 426E (1-10)





**Statische- und angetriebene Werkzeuge für Sauter- und Diplomatic-
Revolver mit Antrieb nach DIN 5480**

*Static and driven tools for Sauter and Diplomatic turret with
coupling according to DIN 5480*

*Porte-outils statiques et motorisés pour tourelle Sauter et
Diplomatic avec connexion conforme DIN 5480*

Statische- und angetriebene Werkzeuge nach DIN 5480
Static and driven Tools coupling according to DIN 5480
Porte-outil entraînés avec connexion conforme DIN 5480

			Page
Statische- und Angetriebene Werkzeuge, Schaft 25 Sauter / Diplomatic	Static and driven tools, shank Ø 25 Sauter / Diplomatic	Porte-outils entraînés 25 Sauter / Diplomatic	5.10 - 5.16.4
Statische- und Angetriebene Werkzeuge, Schaft 30 Sauter / Diplomatic	Static and driven tools, shank Ø 30 Sauter / Diplomatic	Porte-outils entraînés 30 Sauter / Diplomatic	5.20 - 5.30.5
Statische- und Angetriebene Werkzeuge, Schaft 40 Sauter / Diplomatic	Static and driven tools, shank Ø 40 Sauter / Diplomatic	Porte-outils entraînés 40 Sauter / Diplomatic	5.70 - 5.76.6



**Statische- und angetriebene Werkzeuge Schaft Ø25 für
Sauter- und Diplomatic-Revolver mit Antrieb nach DIN 5480**

*Static and driven tools with shank Ø25 for Sauter and
Diplomatic turret with coupling according to DIN 5480*

*Porte-outils statiques et motorisés avec VDI25 pour tourelle Sauter
et Douplomatic avec connexion conforme DIN 5480*

Spannzangenhalter

Collet chuck

Porte pince

Bestell Nr Order No.	d	L ₁	L ₂	Spannzange (siehe 1.27) Collet (see 1.27)
31.2525 MFT L	42	60	---	RD/ER 25 430E
31.2525 MFT R	42	---	60	RD/ER 25 430E
31.2525D MFT	42	60	60	RD/ER 25 430E
31.2532 MFT L	50	64	---	RD/ER 32 470E
31.2532 MFT R	50	---	64	RD/ER 32 470E
31.2532D MFT	50	64	64	RD/ER 32 470E

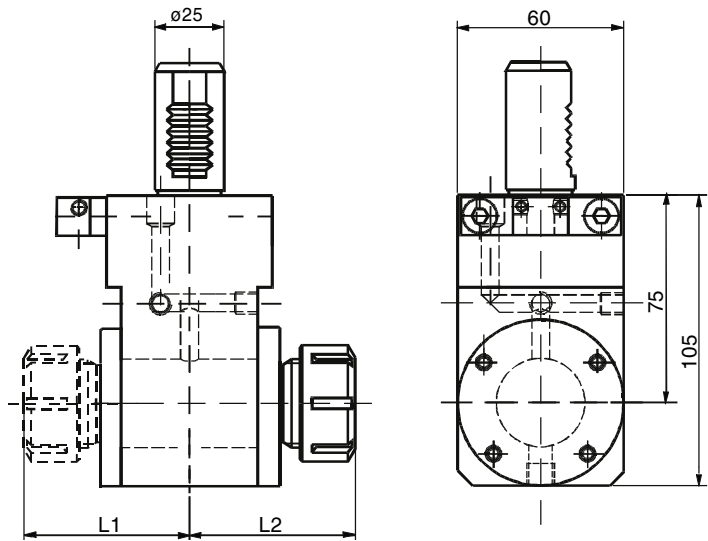

Kombi-Halter

Combi holder

Porte outil combiné

Reduzierbuchsen siehe Katalog Rubrik 1, Seite 1.20
Reducing sleeves see Catalogue chapter 1, page 1.20

Bestell Nr Order No.	d
17.2525 MFT	25
17.2532 MFT	32

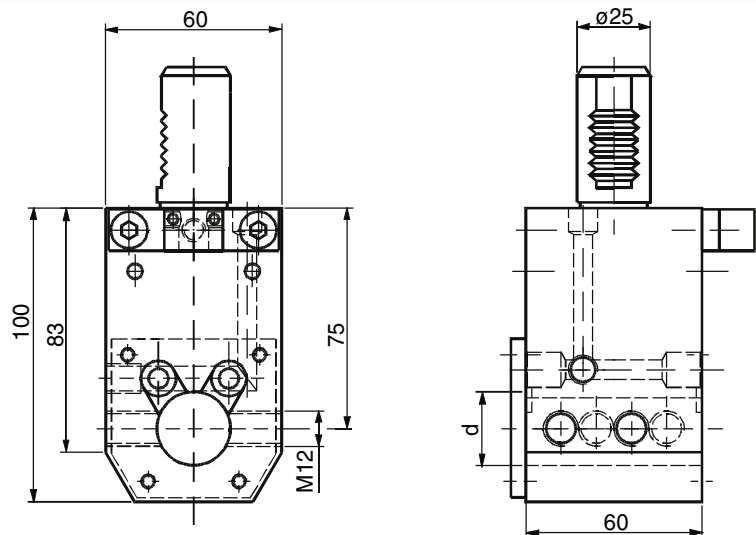

Doppel Bohrstangenhalter

Double boring bar holder

Porte barré d'alesage double

Reduzierbuchsen siehe Katalog Rubrik 1, Seite 1.20
Reducing sleeves see Catalogue chapter 1, page 1.20

Bestell Nr Order No.	d
17.2525D MFT	25
17.2532D MFT	32

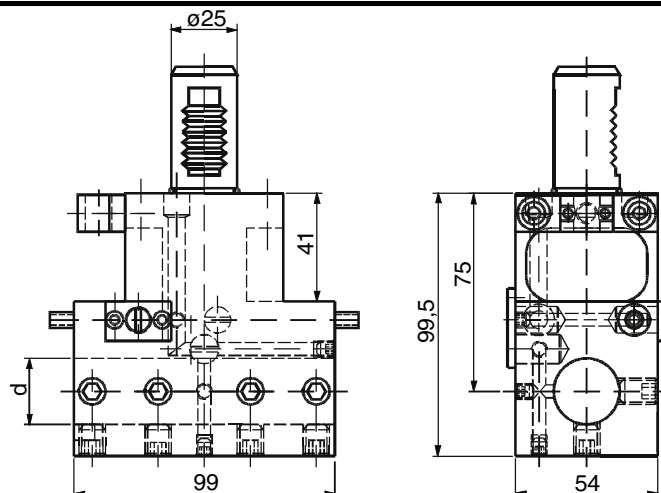

Bohrstangen- halter

Boring bar holder

Porte barré d'alésage

Bestell Nr Order No.	d
19.2525 MFT	25
19.2532 MFT	32

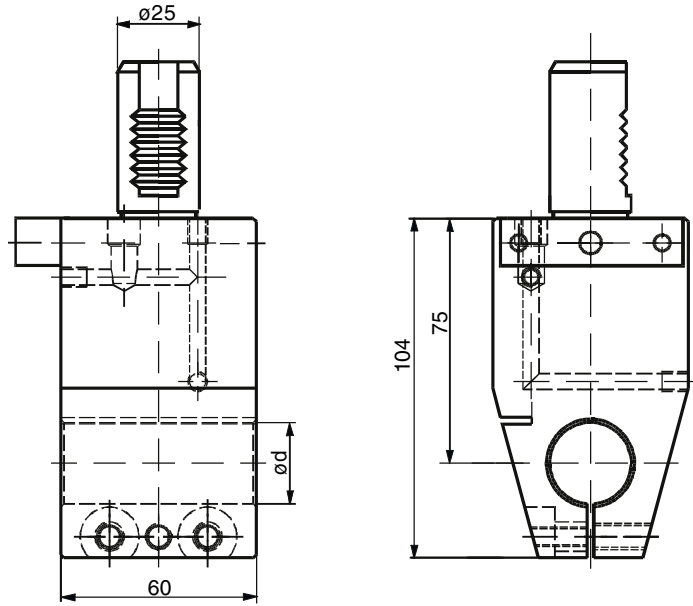

Doppel- drehhalter

Double turning toolholder

Porte outil double coté

Bestell Nr Order No.	
15.2516 E332	

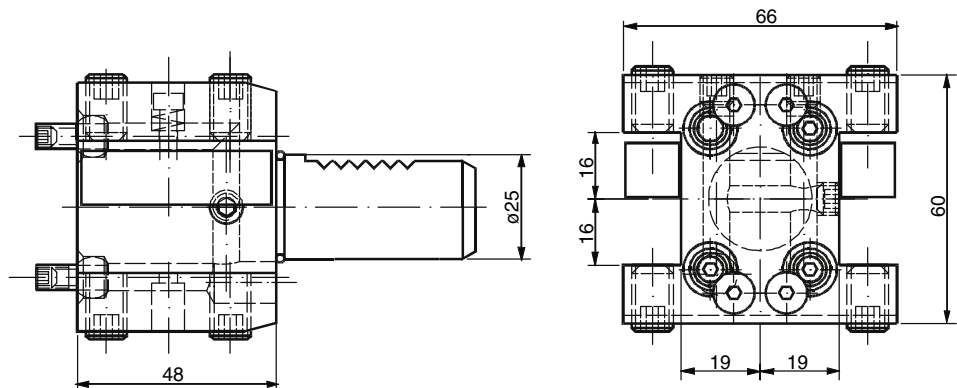

Vierkant- Queraufnahme

Turning tool- holder radial

Radial porte outil carré

Bestell Nr Order No.	
5.2516 E332	

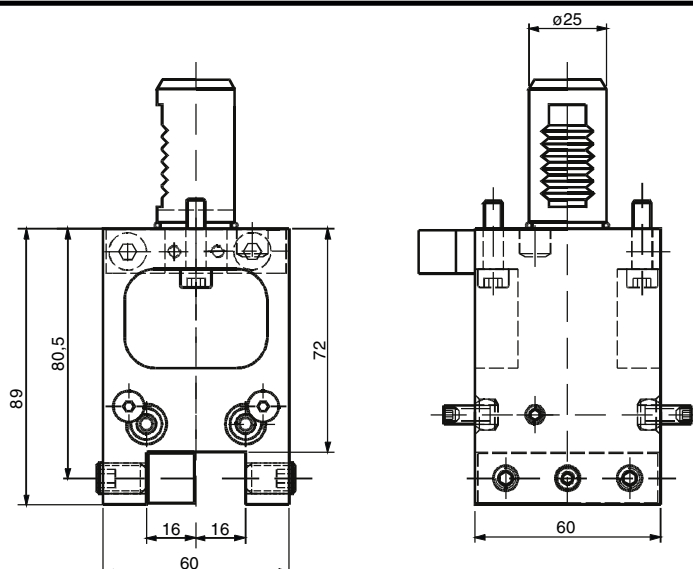

Drehhalter

Turning Tool holder

Porte-outil de tournage

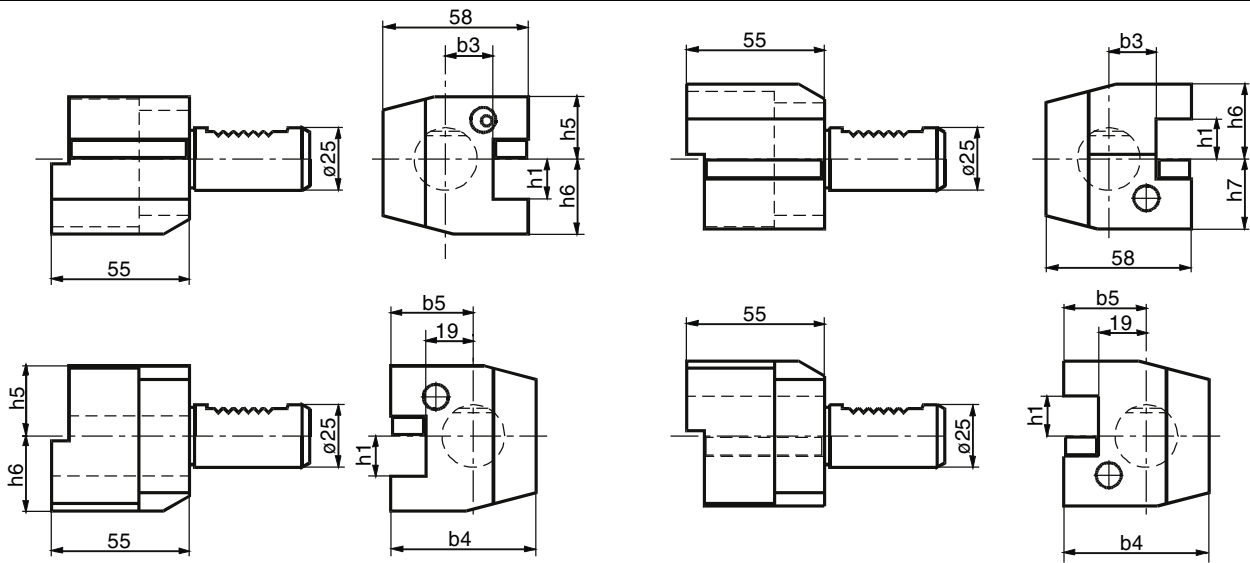

Form	C1				C2					C3				C4							
Nr./No.	h_1	h_5	h_6	b_3	Nr./No.	h_1	h_5	h_6	b_4	b_5	Nr./No.	h_1	h_6	h_7	b_3	Nr./No.	h_1	h_6	h_7	b_4	b_5
1.2516/12	16	25	30	19	4.2516/12	16	25	30	58	33	2.2516/12	16	30	25	19	3.2516/12	16	30	25	58	33
1.2520	20	28	38	15	4.2520	20	28	38	62	37	2.2520	20	38	28	15	3.2520	20	38	28	62	37

Abstechhalter, höhenverstellbar Infeed toolholder, height adjustable Porte outil plongée, réglable

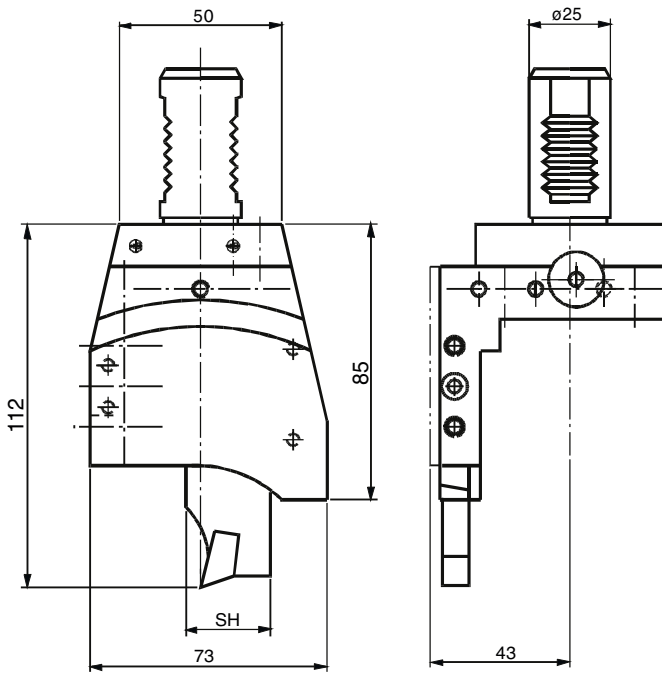

Bestell Nr Order No.	d	
32.2526 G200 RL	26	wie gezeichnet / as shown
32.2526 G200 RL ÜK	26	spiegelbildlich / mirror image
32.2532 G200 RL	32	wie gezeichnet / as shown
32.2532 G200 RL ÜK	32	spiegelbildlich / mirror image

Werkstoffanschlag verstellbar Stock stop Porte-outil à buté de longueur

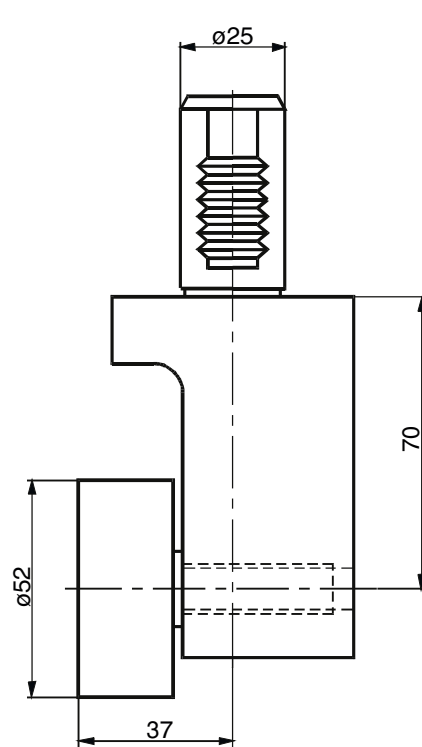

Bestell Nr Order No.
25.500 G200



Axial Bohr- und Fräskopf

Axial drilling and milling head

Tête de perçage et fraiseage

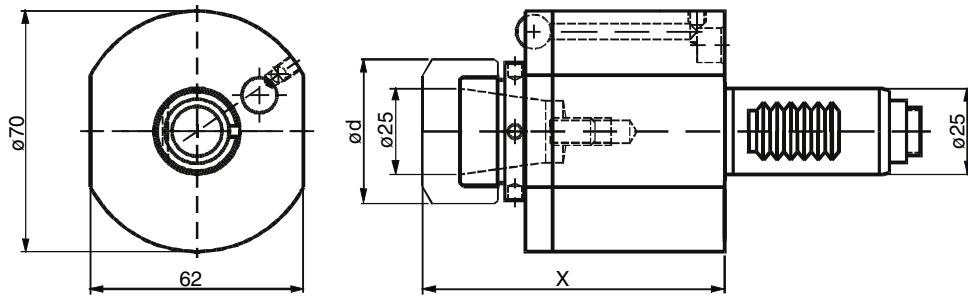

Bestell Nr Order No.	d	i	X	n_{max} [1/min]	T_{max} [Nm]	Schlüsselsatz Wrench-set	Spannzange (siehe 1.27) Collet (see 1.27)
40.2520K5480	35	1:1	69	6000	25	220/HS40	RD/ER 20 428E / *ET1-20
40.2525K5480	42	1:1	70	6000	25	225/HS40	RD/ER 25 430E / *ET1-25

Axial Bohr- und Fräskopf

Axial drilling and milling head

Tête de perçage et fraiseage

**Neu
new
i = 1:2**

Rechts wie gezeichnet
links spiegelbildlich
Right hand as shown
left hand reversed

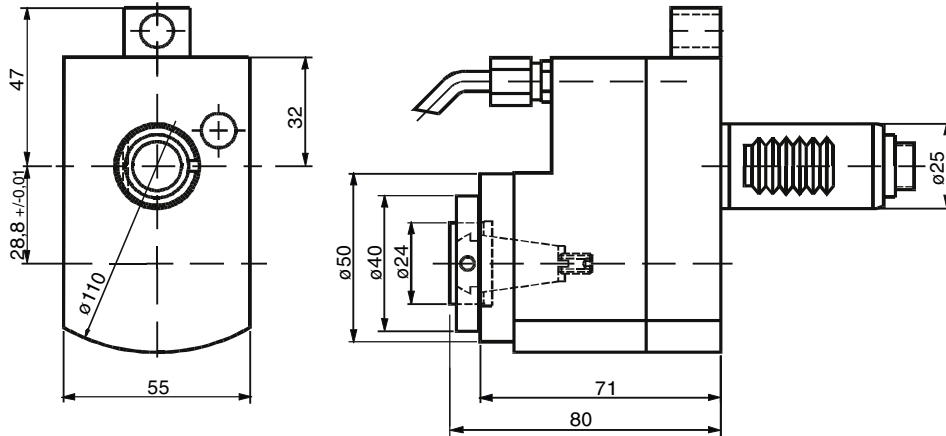

Bestell Nr Order No.	i	n_{max} [1/min]	T_{max} [Nm]	Schlüsselsatz Wrench-set	Spannzange (siehe 1.27) Collet (see 1.27)
50.2516 5480 L/1	1:2	12000	8	LS16 / HS40	RD/ER 16 426E (1-10)
50.2516 5480 R/1	1:2	12000	8	LS16 / HS40	RD/ER 16 426E (1-10)

Axial Bohr- und Fräskopf

Axial drilling and milling head

Tête de perçage et fraiseage

**Neu
new
i = 1:3**

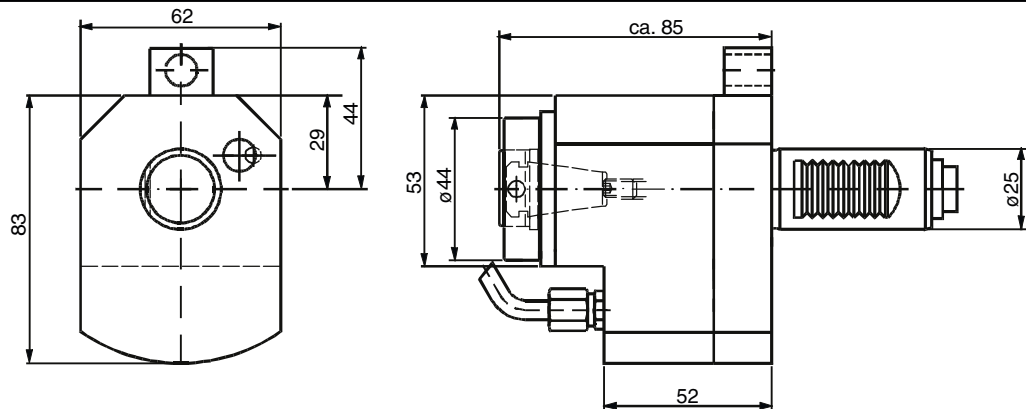

Bestell Nr Order No.	i	n_{max} [1/min]	T_{max} [Nm]	Schlüsselsatz Wrench-set	Spannzange (siehe 1.27) Collet (see 1.27)
40.2516 5480 / 13	1:3	18000	5	LS16 / HS40	RD/ER 16 426E (1-10)

Axial Fräskopf

Axial milling head

Tête de fraisage axial

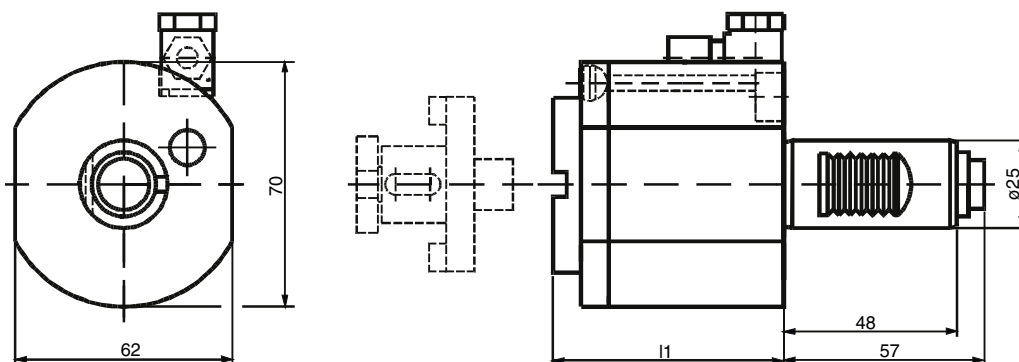

Bestell Nr Order No.	i	n_{max} [1/min]	T_{max} [Nm]	l1
42.25005480	1:1	6000	25	66
42.2500K5480	1:1	6000	25	49

Einsätze siehe Seite 5.16.4
Inserts see page 5.16.4

Radial Bohr- und Fräskopf

Radial drilling and milling head

Tête de perçage et fraisage radial

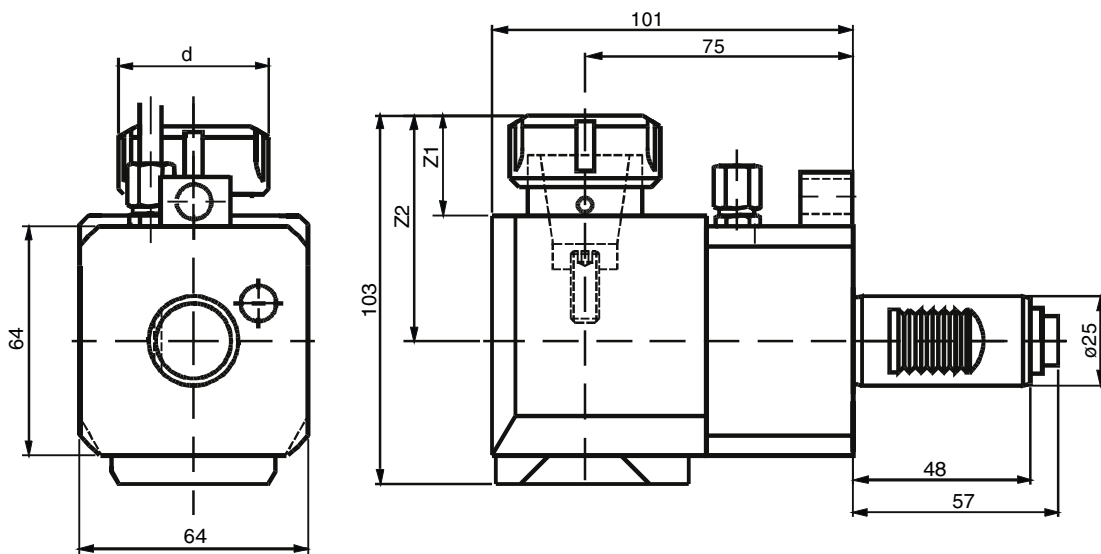

Ausführung L wie gezeichnet
left hand design as shown
à gauche suivant croquis

Ausführung R spiegelbildlich
right hand design reversed
à droite inversé

Bestell Nr Order No.	i	n_{max} [1/min]	T_{max} [Nm]	z_1	z_2	d	Schlüsselsatz Wrench-set	Spannzange (siehe 1.27) Collet (see 1.27)
60.2520 L5480 L	1:1	6000	16	27	62	35	GS30 / HS40	RD/ER 20 428E / *ET1-20 (2-13)
60.2520 L5480 R	1:1	6000	16	27	62	35	GS30 / HS40	RD/ER 20 428E / *ET1-20 (2-13)
60.2525 L5480 L	1:1	6000	16	28	63	42	225 / HS40	RD/ER 25 430E / *ET1-25 (2-16)
60.2525 L5480 R	1:1	6000	16	28	63	42	225 / HS40	RD/ER 25 430E / *ET1-25 (2-16)
60.2520 L5480 L/1	1:2	12000	12	27	62	35	GS30 / HS40	RD/ER 20 428E / *ET1-20 (2-13)
60.2520 L5480 R/1	1:2	12000	12	27	62	35	GS30 / HS40	RD/ER 20 428E / *ET1-20 (2-13)
60.2525 L5480 L/2	2:1	3000	32	28	63	42	225 / HS40	RD/ER 25 430E / *ET1-25 (2-16)
60.2525 L5480 R/2	2:1	3000	32	28	63	42	225 / HS40	RD/ER 25 430E / *ET1-25 (2-16)

Radial Bohr- und Fräskopf

Radial drilling and milling head

Tête de perçage et fraisage radial

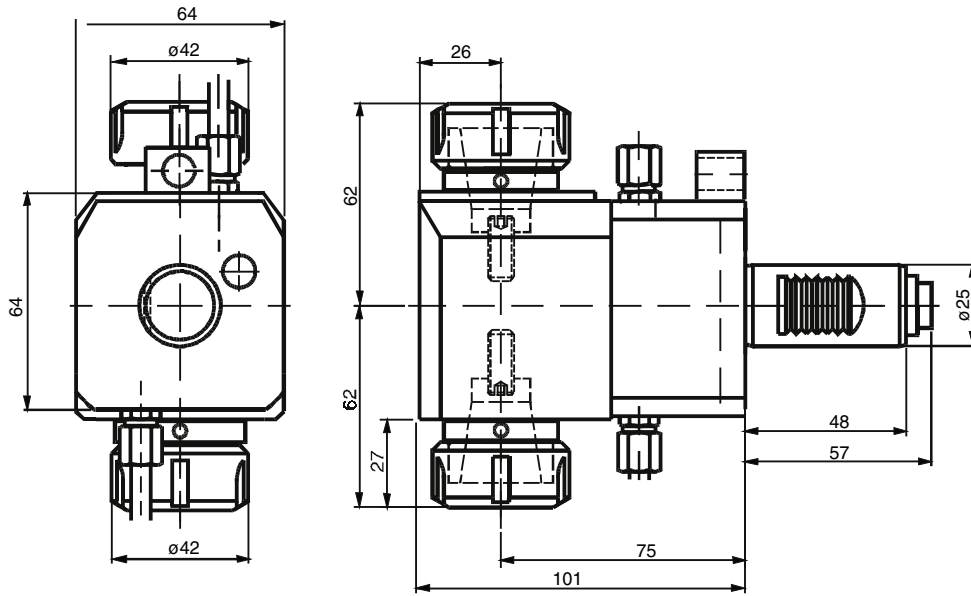

Bestell Nr Order No.	i	n_{\max} [1/min]	T_{\max} [Nm]	Schlüsselsatz Wrench-set	Spannzange (siehe 1.27) Collet (see 1.27)
60.2525 LD5480	1:1	6000	16	225 / HS40	RD/ER 25 430E / *ET1-25 (2-16)

Radial Bohr- und Fräskopf

Radial drilling and milling head

Tête de perçage et fraisage radial

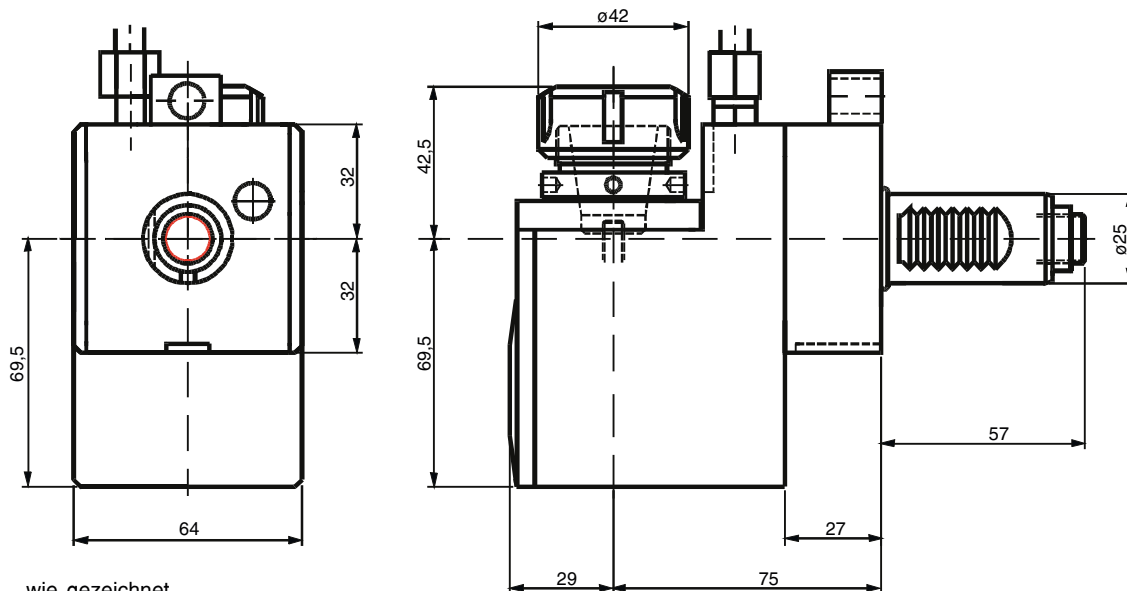

Ausführung L wie gezeichnet
left hand design as shown
à gauche suivant croquis

Ausführung R spiegelbildlich
right hand design reversed
à droite inversé

Bestell Nr Order No.	i	n_{\max} [1/min]	T_{\max} [Nm]	Schlüsselsatz Wrench-set	Spannzange (siehe 1.27) Collet (see 1.27)
80.2525 L5480 L	1:1	6000	16	225 / HS40	RD/ER 25 430E / *ET1-25 (2-16)
80.2525 L5480 R	1:1	6000	16	225 / HS40	RD/ER 25 430E / *ET1-25 (2-16)

Radial Fräskopf

Radial milling head

Tête de fraisage radial

Ausführung L wie gezeichnet
left hand design as shown
à gauche suivant croquis

Ausführung R spiegelbildlich
right hand design reversed
à droite inversé

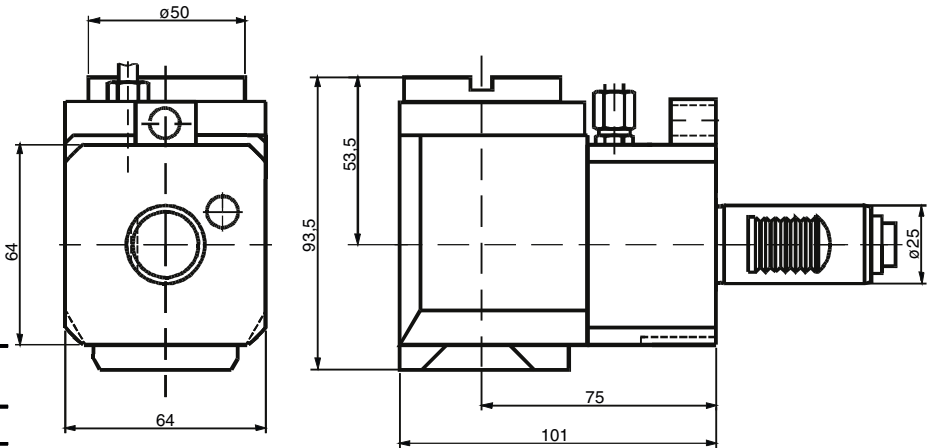

Bestell Nr Order No.	i	n_{max} [1/min]	T_{max} [Nm]
62.2500 L5480 L	1:1	6000	16
62.2500 L5480 R	1:1	6000	16
62.2500 L5480 L/2	2:1	3000	32
62.2500 L5480 R/2	2:1	3000	32

Fräshaltstück

zu 42.2500E332 und 62.2500E332

Milling arbor inserts

for 42.2500E332
and 62.2500E332

Adaptateur de fraisage

pour 42.2500E332
et 62.2500E332

Bestell Nr Order No.	d	x
501.0507	13	24
501.0510	16	29
501.0520	22	31
501.0530	27	33

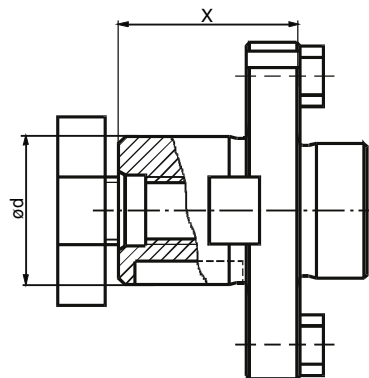

Schwenkkopf ±105°

Swivel level ±105°

Tête pivotante ±105°

Bestell Nr Order No.	i	X_1	X_2	X_3	d
63.2520 E332	1:1	58	26	115	35
63.2520L E332	1:1	75	26	132	35
63.2516 E332 / 1	1:2	51	25	100	32
63.2516L E332 / 1	1:2	68	25	127	32

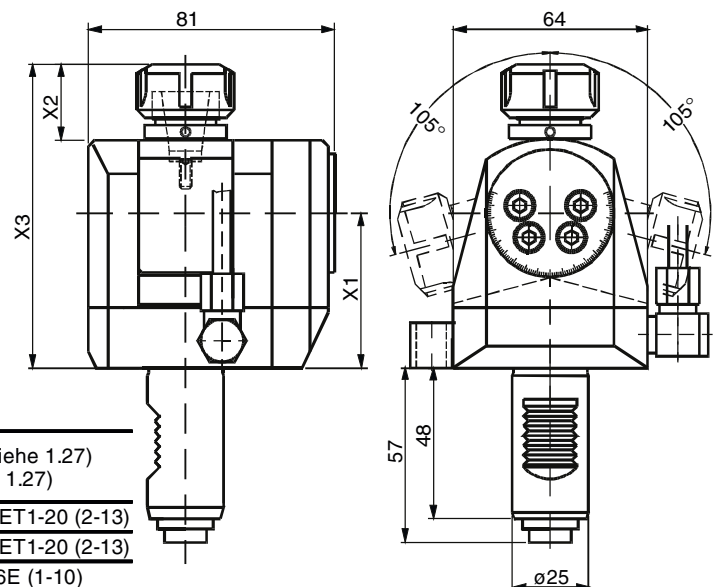

Bestell Nr Order No.	n_{max} [1/min]	T_{max} [Nm]	Schlüssel- satz Wrench-set	Spannzange (siehe 1.27) Collet (see 1.27)
63.2520 E332	6000	16	GS 30	RD/ER 20 428E / *ET1-20 (2-13)
63.2520L E332	6000	16	GS 30	RD/ER 20 428E / *ET1-20 (2-13)
63.2516 E332 / 1	12000	8	GS 30	RD/ER 16 426E (1-10)
63.2516L E332 / 1	12000	8	GS 30	RD/ER 16 426E (1-10)



**Statische- und angetriebene Werkzeuge Schaft Ø30 für
Sauter- und Diplomatic-Revolver mit Antrieb nach DIN 5480**

*Static and driven tools with shank Ø30 for Sauter and
Diplomatic turret with coupling according to DIN 5480*

*Porte-outils statiques et motorisés avec VDI30 pour tourelle Sauter
et Douplomatic avec connexion conforme DIN 5480*

Ausgleichhalter

für Werkzeugaufnahmen
mit Schaft nach DIN 69880
ø 30 x 55

Adaptor

for toolholders
DIN 69880 shaft 30

Adapteur

pour porte-outil
DIN 69 880 dia. 30

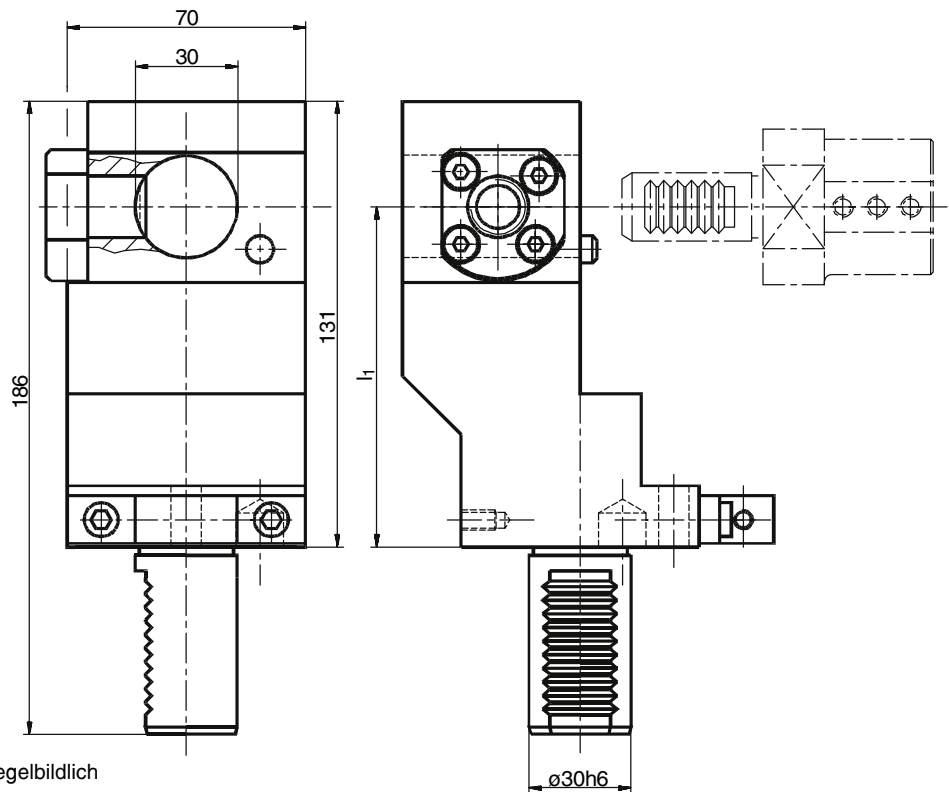

Bestell Nr. Order No.	l ₁
WA 3030 CTX R	85
WA 3030 CTX L	85
WA 3030L CTX R	100
WA 3030L CTX L	100

Ausführung CTX L, wie gezeichnet, R spiegelbildlich
Design CTX L, as shown, R reversed
Dessin CTX L, R inversé

Bohrhalter

Drill Holder

Porte-foret

5

Bestell Nr. Order No.	h ₁	l ₁	d	l ₃	Spannzange Collet Pince
31.3025 CTX R	85	60	42	-	250 430 E
31.3025 CTX L	85	-	42	60	250 430 E
31.3025 D CTX	85	60	42	60	250 430 E
31.3032 CTX R	85	70	50	-	320 470 E
31.3032 CTX L	85	-	50	70	320 470 E
31.3032 D CTX	85	70	50	70	320 470 E
31.3040 CTX R	85	75	63	-	400 472 E
31.3040 CTX L	85	-	63	75	400 472 E
31.3040 D CTX	85	75	63	75	400 472 E
31.3025 L CTX R	100	60	42	-	250 430 E
31.3025 L CTX L	100	-	42	60	250 430 E
31.3025 L D CTX	100	60	42	60	250 430 E
31.3032 L CTX R	100	70	50	-	320 470 E
31.3032 L CTX L	100	-	50	70	320 470 E
31.3032 L D CTX	100	70	50	70	320 470 E
31.3040 L CTX R	100	75	63	-	400 472 E
31.3040 L CTX L	100	-	63	75	400 472 E
31.3040 L D CTX	100	75	63	75	0 472 E

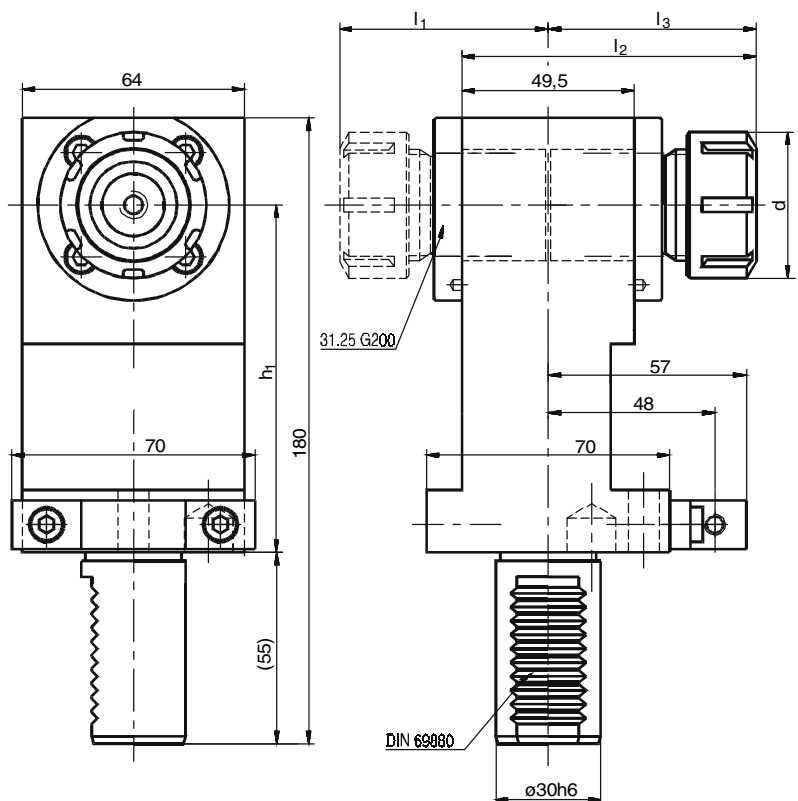

Ausführung CTX L, wie gezeichnet, R spiegelbildlich
Design CTX L, as shown, R reversed
Dessin CTX L, R inversé

D für Haupt- und Gegenspindel
D for main and subspindle
D pour broche et contre broche

Kombihalter

Combi toolholder

Porte-outil combiné

Bestell Nr. Order No.	l_1	$\varnothing d$
17.3025 CTX	85	25
17.3025 L CTX	100	25

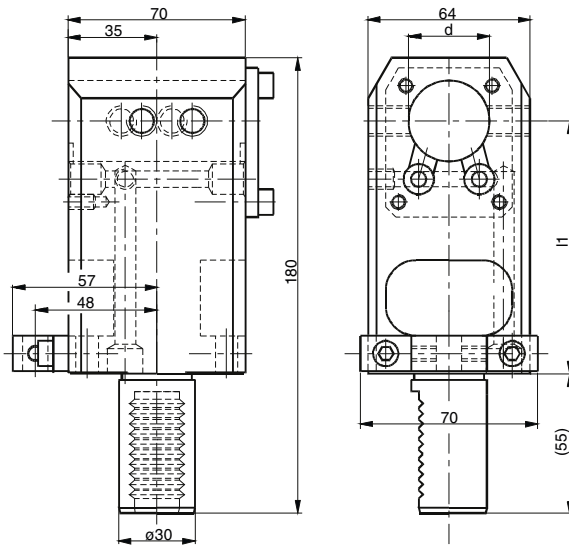

Aufnahmehülsen

Adaptor Sleeve

Douille de réduction

Nr. / No.	d_1	d_2	d_3	l_1	l_2
28.3225 G200	32	25	40	63	58
28.3220 G200	32	20	40	63	58
28.3216 G200	32	16	40	63	58
28.3212 G200	32	12	40	63	58
28.3210 G200	32	10	40	63	58
28.3208 G200	32	08	40	63	58

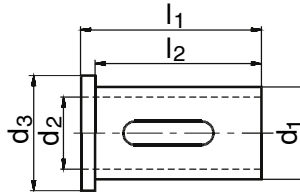

Nr. / No.	d_1	d_2	d_3	l_1	l_2
28.2520 S	25	20	29	50	46
28.2516 S	25	16	29	50	46
28.2512 S	25	12	29	50	46
28.2510 S	25	10	29	50	46
28.2508 S	25	08	29	50	46

Bohrer-Einsatzhülsen

Drill Insert Sleeves

Douille pour foret

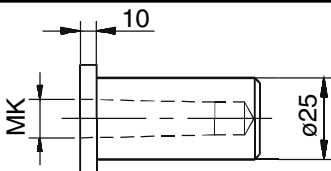

Nr. / No.	MK
QT 831	1
QT 832	2

Gewindeschneid- Schnellwechselfutter

Thread Cutting quick-change Chuck

Porte foret pour taraud à serrage rapide

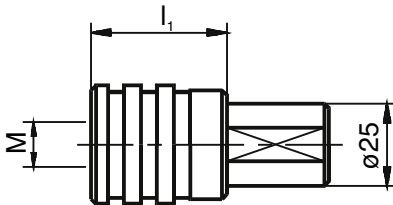

Nr. / No.	l_1	M
WFLK 1/25	41	M3 - M12
WFLK 2/25	64	M8 - M20

Pendelhalter

Floating Reamer Holder

Mandrins flottant

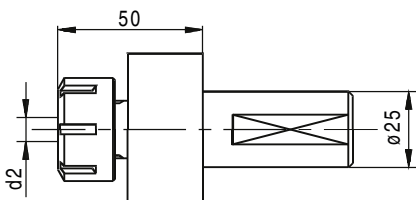

Nr. / No.	d_2	Spannzange / Collet / Pince
0250025	1 - 16	250 430 E

**Kombihalter
und Aufnahmhülsen**

**Combi toolholder
and Adaptor Sleeve**

**Porte-outil combiné et
douille de réduction**

Bestell Nr. Order No.	l_1	$\varnothing d$
17.3032 CTX	85	32
17.3040 CTX	85	40
17.3032 L CTX	100	32
17.3040 L CTX	100	40

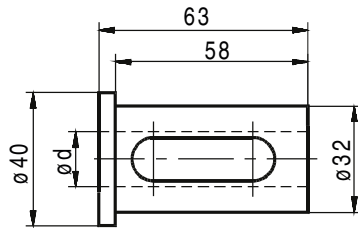

Nr. / No.	d
28.3206 G200	06
28.3208 G200	08
28.3210 G200	10
28.3212 G200	12
28.3216 G200	16
28.3220 G200	20
28.3225 G200	25
28.3225,4 G200	25,4 (1")

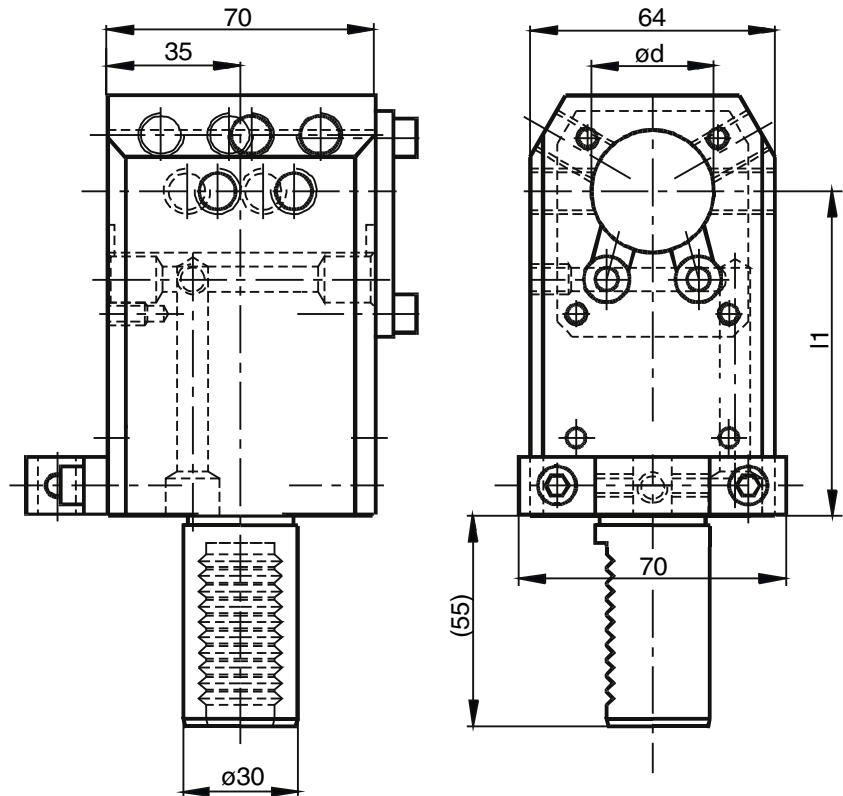

**Kombihalter
rechts / links**

**Combiholder
right- and lefthand**

**Porte-outil combiné
droite and gauche**

Bestell Nr. Order No.	l_1	$\varnothing d$
17.3032 D CTX	85	32
17.3032 L D CTX	100	32

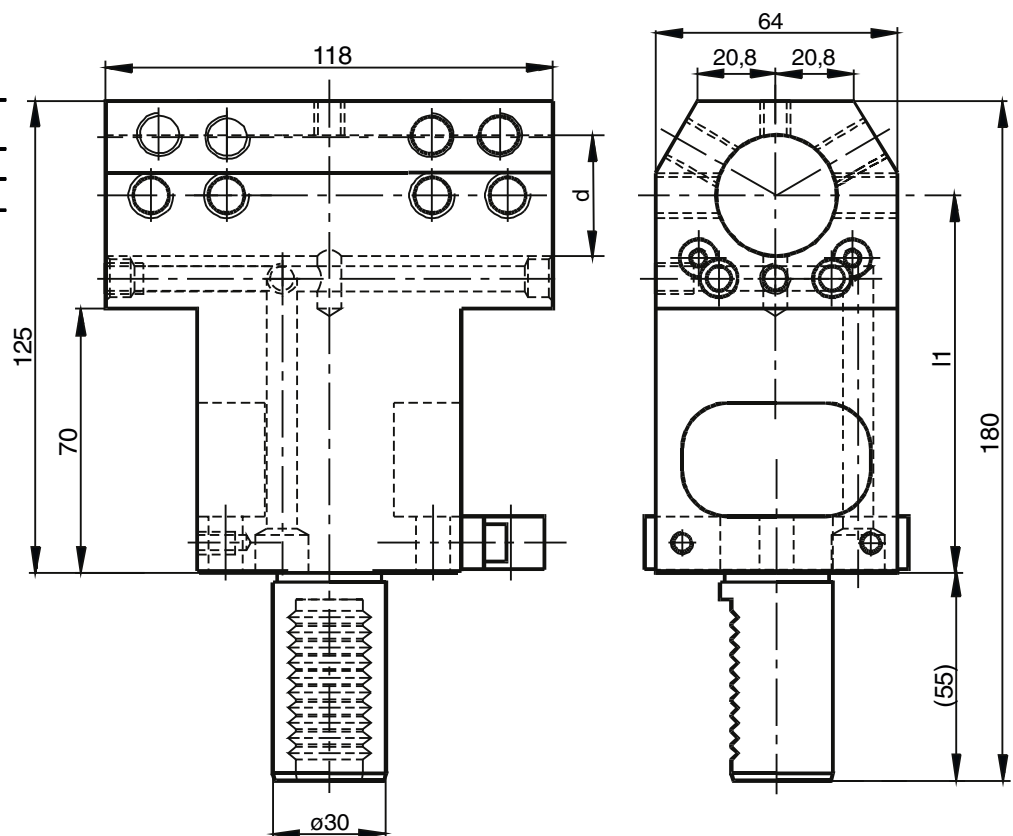

Werkstoffanschlag

Stock Stop

Porte-outil à buté
de longueur

Bestell Nr. Order No.	l_1
25.500 CTX	85
25.500 L CTX	100

Andere \varnothing auf Anfrage.
Other \varnothing on request.
Autre \varnothing on demande.

Für alle Maschinen
For all machines
Pour toute machines

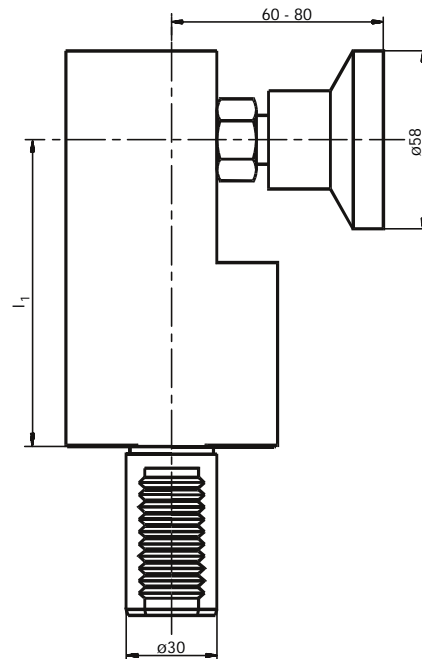

Abstechhalter für Stahlhöhe SH 32/26

Infeed Toolholder
SH 32/26

Porte-outil de
plongée SH 32/26

Für alle Maschinen
For all machines
Pour toute machines

Bestell Nr. Order No.	SH	
32.3032 CTX RL ÜK	32	wie gezeichnet
32.3032 CTX RL	32	Schneide spiegelbildlich
32.3026 CTX RL ÜK	26	wie gezeichnet
32.3026 CTX RL	26	Schneide spiegelbildlich

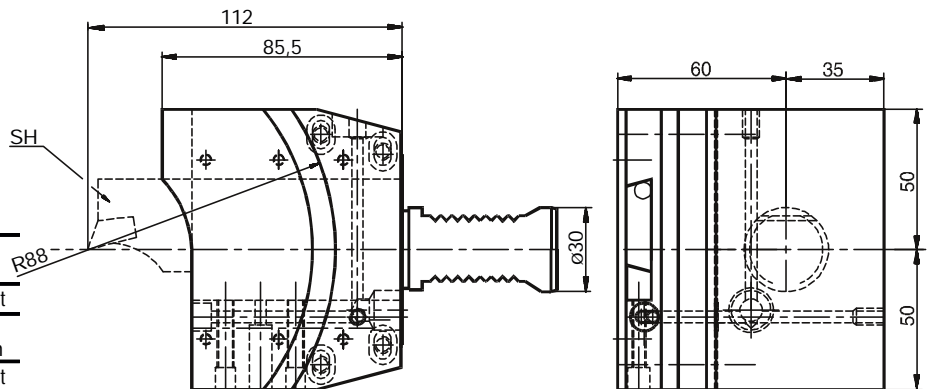

Doppel-Drehhalter

Double turning
toolholder

Porte-outil
doubl-coté

Bestell Nr. Order No.	
300.2000 G300	

Für alle Maschinen
For all machines
Pour toute machines

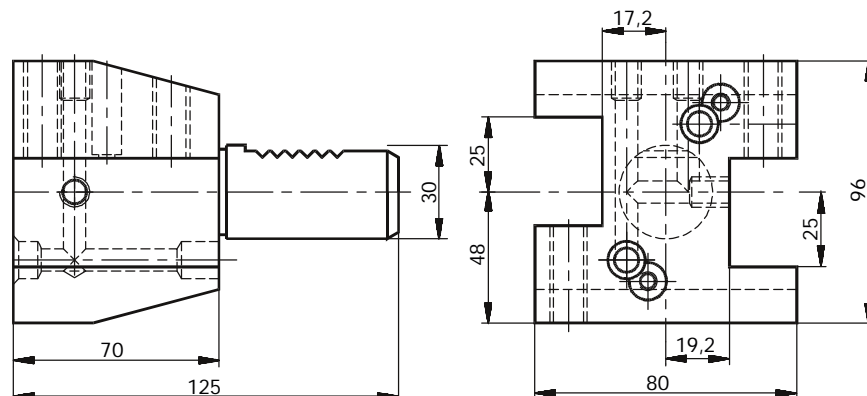

Drehhalter

Turning Tool Holder

Porte-outil de tournage

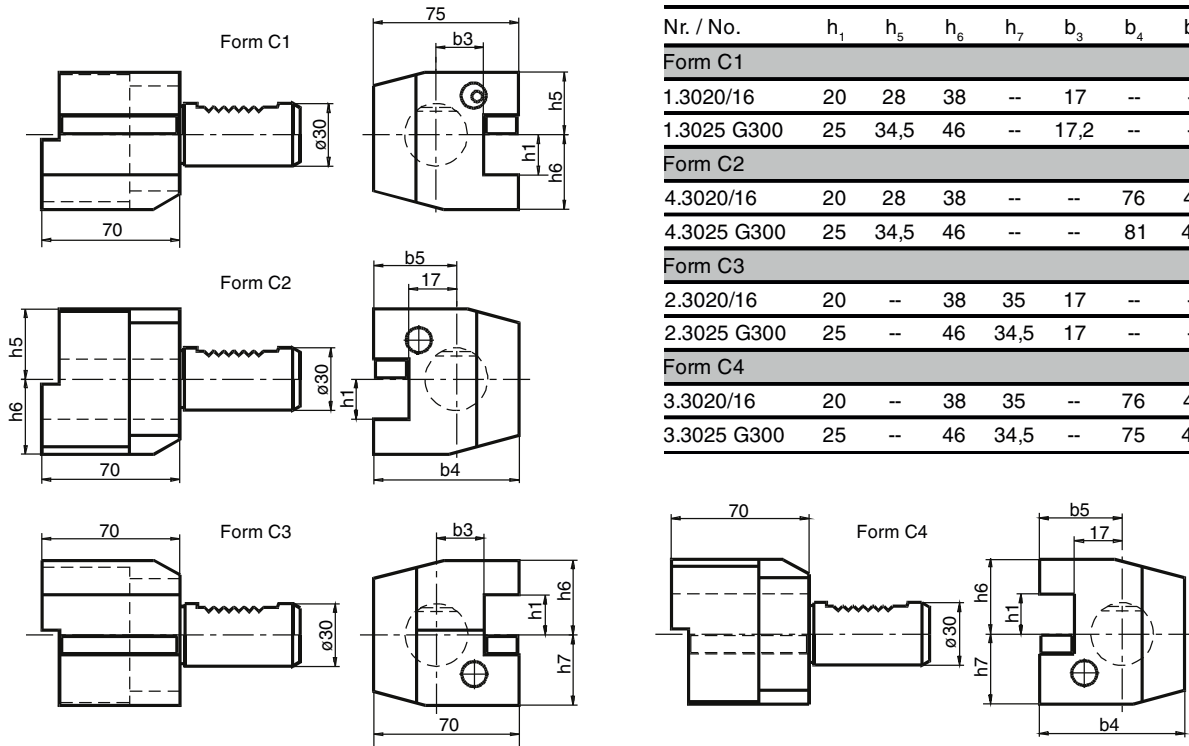

Nr. / No.	h_1	h_5	h_6	h_7	b_3	b_4	b_5
Form C1							
1.3020/16	20	28	38	--	17	--	--
1.3025 G300	25	34,5	46	--	17,2	--	--
Form C2							
4.3020/16	20	28	38	--	--	76	41
4.3025 G300	25	34,5	46	--	--	81	46
Form C3							
2.3020/16	20	--	38	35	17	--	--
2.3025 G300	25	--	46	34,5	17	--	--
Form C4							
3.3020/16	20	--	38	35	--	76	41
3.3025 G300	25	--	46	34,5	--	75	46

Vierkant Queraufnahme

Turning tool radial

Radial-Porte-outil carré

Bestell Nr. Order No.	
5.3025 G300	wie gezeichnet as shown suivant croquis
6.3025 G300	spiegelbildlich reversed inverse
5.3025 G300 RL	mit doppelverzahntem DIN-Schaft with doubletoothed DIN shaft universelle pour broche et contre-broche

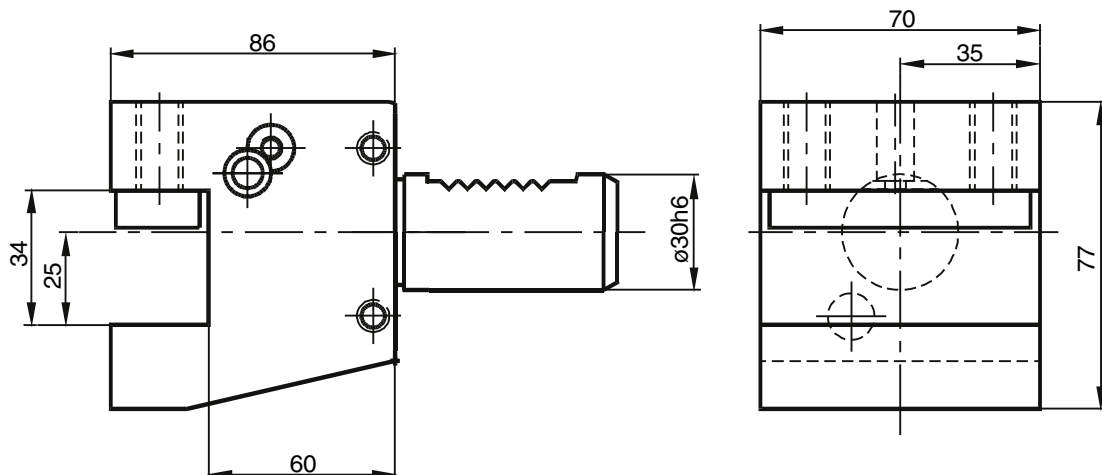



Axial Bohr-
und Fräskopf

Axial drilling and
milling head

Tête de perçage
et fraisage

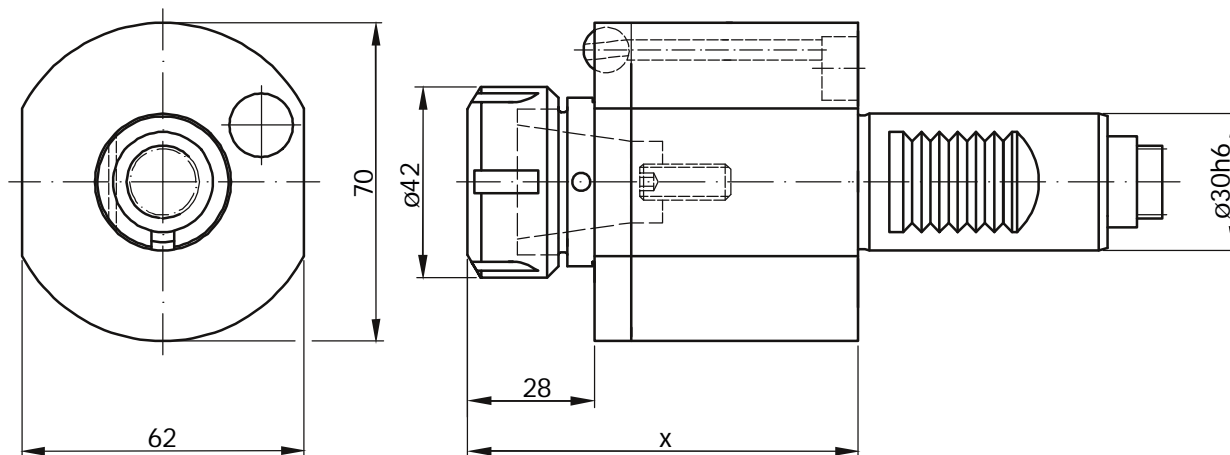

Innere Kühlmittelzufuhr. Zusatz IK an Bestellnummer anfügen.
Central cooling supply. Please add IK behind order no.

Bestell Nr. Order No.	i	x	n_{\max} [1/min]	T_{\max} [Nm]	Schlüsselsatz Wrench-set	Spannzange (siehe 1.27) Collet (see 1.27)
40.3025 CTX	1:1	86	6000	25	225/HS40	RD/ER 25 430E/*ET1-25 (2-16)
40.3025K CTX	1:1	71	6000	25	225/HS40	RD/ER 25 430E/*ET1-25 (2-16)

* Zum Gewindeschneiden, siehe Kapitel 8, Seite 12
For tapping, see chapter 8, page 12

Axial Bohr-
und Fräskopf

Axial drilling and
milling head

Tête de perçage
et fraisage

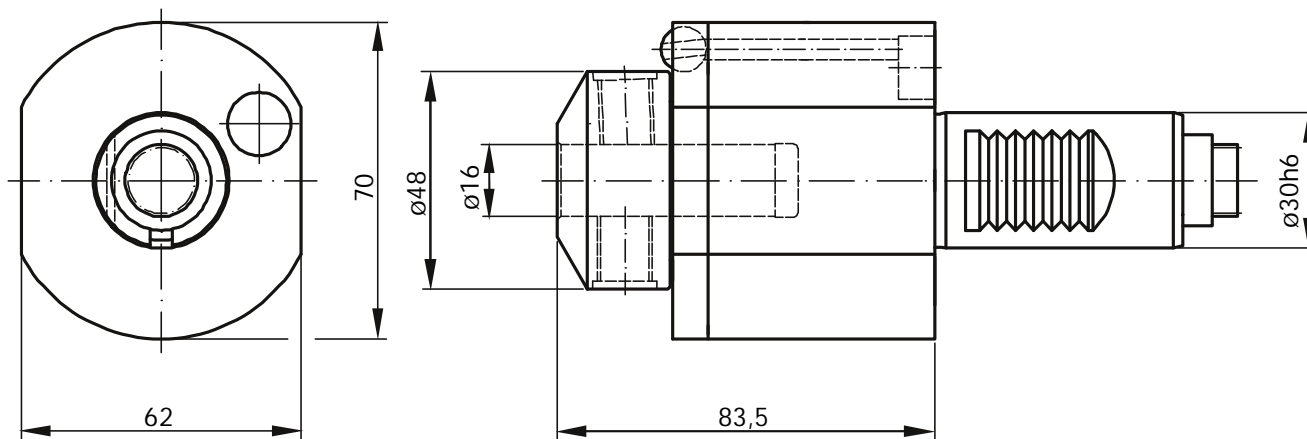

Innere Kühlmittelzufuhr. Zusatz IK an Bestellnummer anfügen.
Central cooling supply. Please add IK behind order no.

Bestell Nr. Order No.	i	n_{\max} [1/min]	T_{\max} [Nm]
40.3016 WN CTX	1:1	6000	25

Axial Bohr- und Fräskopf

Axial drilling and milling head

Tête de perçage et fraisage

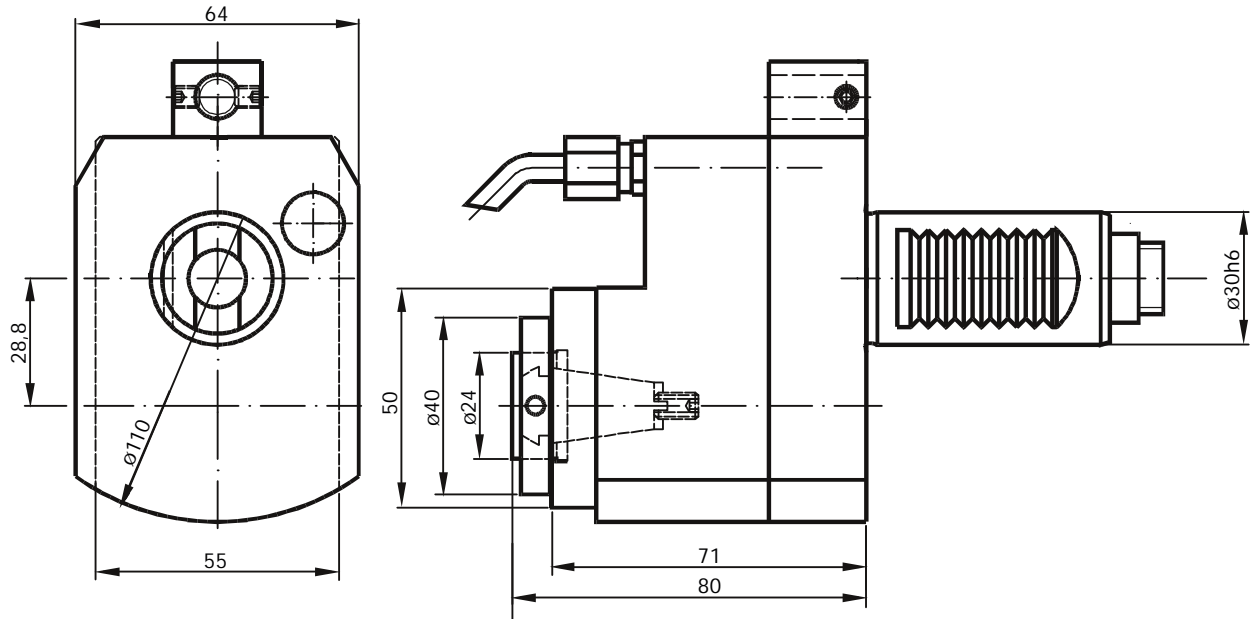

Innere Kühlmittelzufuhr. Zusatz IK an Bestellnummer anfügen.
Central cooling supply. Please add IK behind order no.

Rechts wie gezeichnet - links spiegelbildlich
right hand as shown - left hand reversed

Bestell Nr. Order No.	i	n_{max} [1/min]	T_{max} [Nm]	Schlüsselsatz Wrench-set	Spannzange (siehe 1.27) Collet (see 1.27)
50.3016 CTX L/1	1:2	12000	8	LS16/HS40	RD/ER 16 426E (1-10)
50.3016 CTX R/1	1:2	12000	8	LS16/HS40	RD/ER 16 426E (1-10)

Gewindebohrkopf

Tapping head

Tête de taraudage

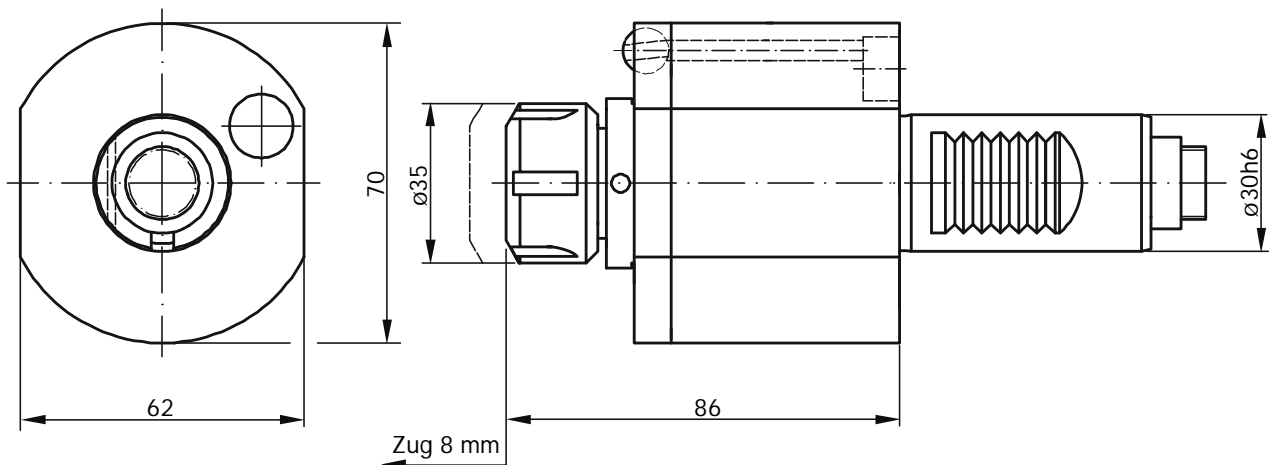

Innere Kühlmittelzufuhr. Zusatz IK an Bestellnummer anfügen.
Central cooling supply. Please add IK behind order no.

Bestell Nr. Order No.	i	n_{max} [1/min]	T_{max} [Nm]	Schlüsselsatz Wrench-set	Spannzange (siehe 1.27) Collet (see 1.27)
41.3020 CTX	1:1	4000	16	GS30/GS...	RD/ER 20 428E (2-13)

Radial Bohr-
und Fräskopf

Radial drilling and
milling head

Tête de perçage
et fraisage radial

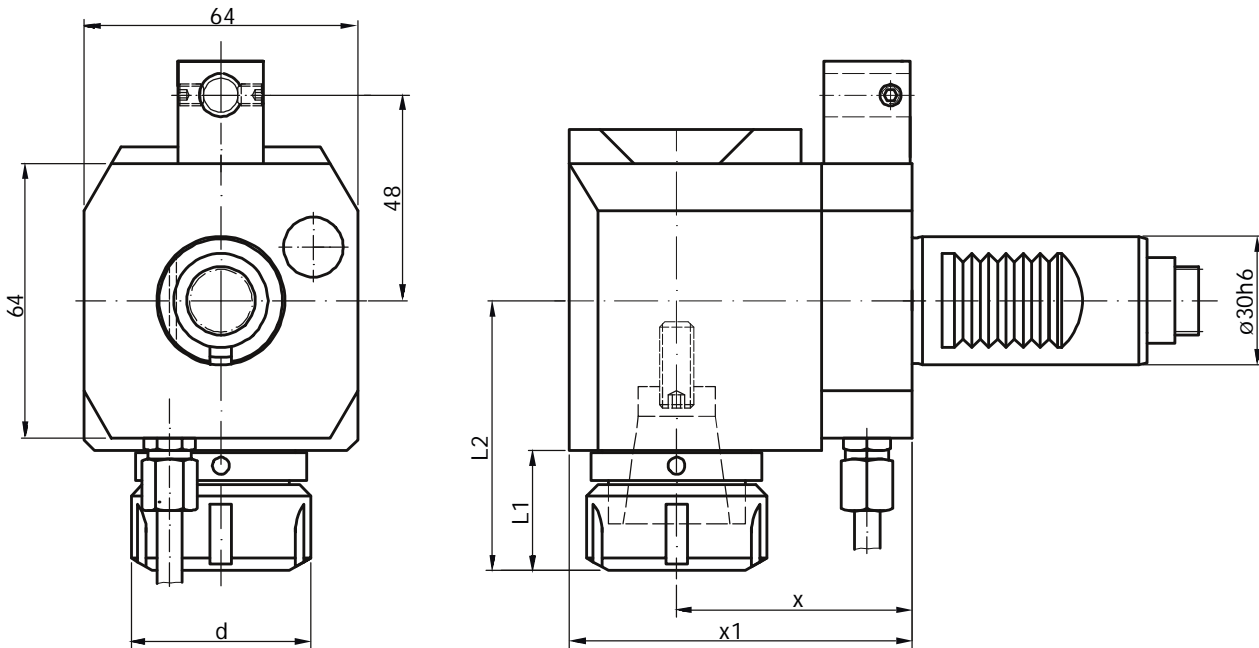

Innere Kühlmittelzufuhr. Zusatz IK an Bestellnummer anfügen.
Central cooling supply. Please add IK behind order no.

Auch mit Doppelverzahnung (Lizenz Traub) lieferbar.
Available with double seration (licence Traub).

Ausführung R: wie gezeichnet
right hand design as shown
à droite suivant croquis

Ausführung L: spiegelbildlich
left hand design reversed
à gauche inversé

Bestell Nr. Order No.	i	x	x ₁	n _{max} [1/min]	L ₁	L ₂	T _{max} [Nm]	d	Schlüsselsatz Wrench-set	Spannzange (siehe 1.27) Collet (see 1.27)
60.3020 CTXR	1:1	55	81	6000	27	62	25	35	GS30/HS40	RD/ER 20 428E / *ET1-20 (2-13)
60.3020 CTXL	1:1	55	81	6000	27	62	25	35	GS30/HS40	RD/ER 20 428E / *ET1-20 (2-13)
60.3020 CTXR/1	1:2	55	81	12000	27	62	16	35	GS30/HS40	RD/ER 20 428E / *ET1-20 (2-13)
60.3020 CTXL/1	1:2	55	81	12000	27	62	16	35	GS30/HS40	RD/ER 20 428E / *ET1-20 (2-13)
60.3020 CTXR/2	2:1	55	81	4000	27	62	32	35	GS30/HS40	RD/ER 20 428E / *ET1-20 (2-13)
60.3020 CTXL/2	2:1	55	81	4000	27	62	32	35	GS30/HS40	RD/ER 20 428E / *ET1-20 (2-13)
60.3020L CTXR	1:1	100	126	6000	27	62	25	35	GS30/HS40	RD/ER 20 428E / *ET1-20 (2-13)
60.3020L CTXL	1:1	100	126	6000	27	62	25	35	GS30/HS40	RD/ER 20 428E / *ET1-20 (2-13)
60.3020L CTXR/1	1:2	100	126	12000	27	62	16	35	GS30/HS40	RD/ER 20 428E / *ET1-20 (2-13)
60.3020L CTXL/1	1:2	100	126	12000	27	62	16	35	GS30/HS40	RD/ER 20 428E / *ET1-20 (2-13)
60.3020L CTXR/2	2:1	100	126	4000	27	62	32	35	GS30/HS40	RD/ER 20 428E / *ET1-20 (2-13)
60.3020L CTXL/2	2:1	100	126	4000	27	62	32	35	GS30/HS40	RD/ER 20 428E / *ET1-20 (2-13)
60.3025 CTXR	1:1	55	81	6000	28	63	25	42	225/HS40	RD/ER 25 430E / *ET1-25 (2-16)
60.3025 CTXL	1:1	55	81	6000	28	63	25	42	225/HS40	RD/ER 25 430E / *ET1-25 (2-16)
60.3025 CTXR/2	2:1	55	81	4000	28	63	32	42	225/HS40	RD/ER 25 430E / *ET1-25 (2-16)
60.3025 CTXL/2	2:1	55	81	4000	28	63	32	42	225/HS40	RD/ER 25 430E / *ET1-25 (2-16)
60.3025L CTXR	1:1	100	126	6000	28	63	25	42	225/HS40	RD/ER 25 430E / *ET1-25 (2-16)
60.3025L CTXL	1:1	100	126	6000	28	63	25	42	225/HS40	RD/ER 25 430E / *ET1-25 (2-16)
60.3025L CTXR/2	2:1	100	126	4000	28	63	32	42	225/HS40	RD/ER 25 430E / *ET1-25 (2-16)
60.3025L CTXL/2	2:1	100	126	4000	28	63	32	42	225/HS40	RD/ER 25 430E / *ET1-25 (2-16)

* Zum Gewindeschneiden siehe Kapitel 8, Seite 12
For tapping see chapter 8, page 12.

Radial Bohr- und Fräskopf

Radial drilling and milling head

Tête de perçage et fraisage radial

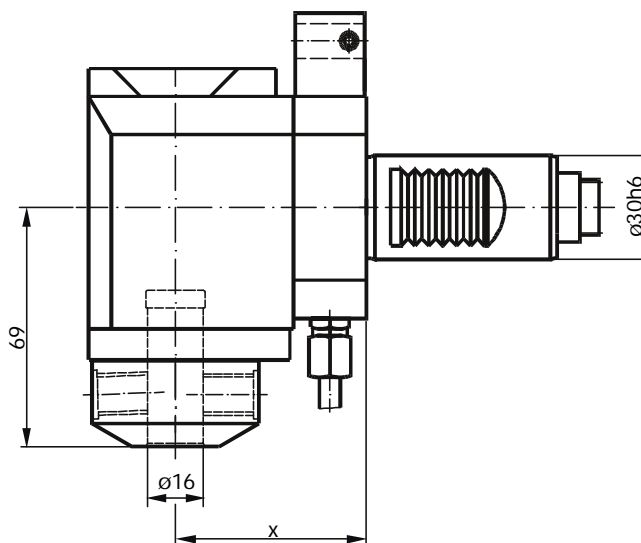
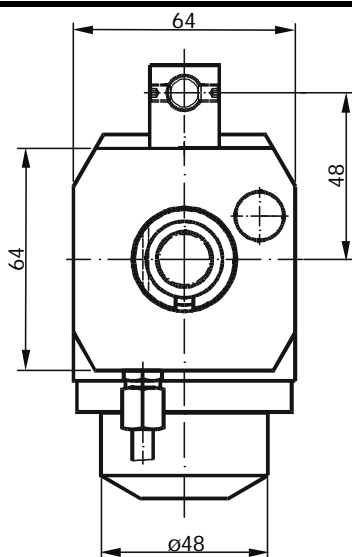

Bestell Nr. Order No.	i	x	n_{max} [1/min]	T_{max} [Nm]
60.3016 WN CTXR	1:1	55	6000	25
60.3016 WN CTXL	1:1	55	6000	25
60.3016 WN CTXR/2	2:1	55	4000	32
60.3016 WN CTXL/2	2:1	55	4000	32
60.3016 WNL CTXR	1:1	100	6000	25
60.3016 WNL CTXL	1:1	100	6000	25
60.3016 WNL CTXR/2	2:1	100	4000	32
60.3016 WNL CTXL/2	2:1	100	4000	32

R: wie gezeichnet
right hand design as shown
à droite suivant croquis

L: spiegelbildlich
left hand design reversed
à gauche inverse

Innere Kühlmittelzufuhr. Zusatz IK an Bestellnummer anfügen.
Central cooling supply. Please add IK behind order no.

Auch mit Doppelverzahnung (Lizenz Traub) lieferbar.
Available with double seration (licence Traub).

Radial Gewindebohrkopf

Radial tapping head

Tête de taraudage radial

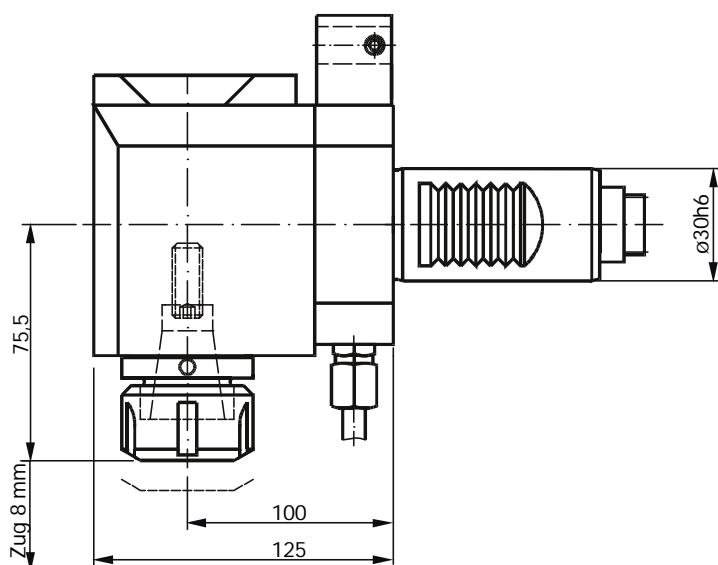
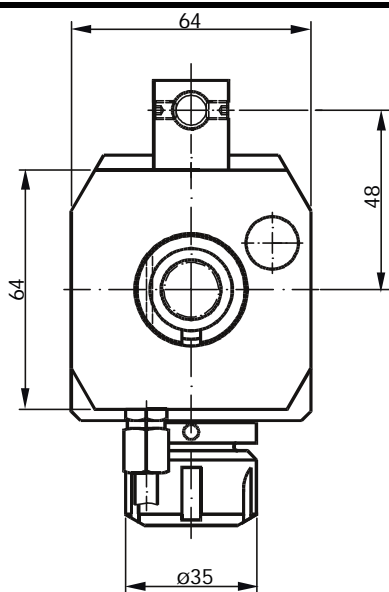

Auch mit Doppelverzahnung (Lizenz Traub) lieferbar.
Available with double seration (licence Traub).

Bestell Nr. Order No.	i	n_{max} [1/min]	T_{max} [Nm]	Schlüsselsatz Wrench-set	Spannzange (siehe 1.27) Collet (see 1.27)
61.3020L CTXR	1:1	4000	25	GS30/GS...	RD/ER 20 428E (1-13)
61.3020L CTXL	1:1	4000	25	GS30/GS...	RD/ER 20 428E (1-13)

Radial Fräskopf

Radial milling head

Tête de fraisage radial

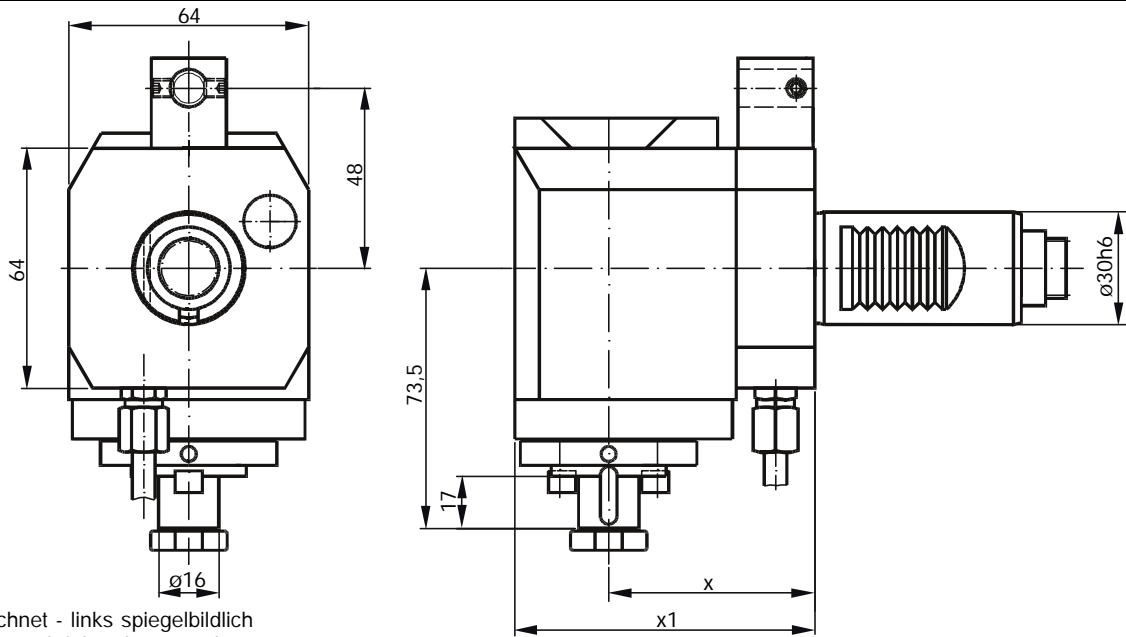

Rechts wie gezeichnet - links spiegelbildlich
right hand as shown - left hand reversed

Bestell Nr. Order No.	i	x	x_1	n_{max} [1/min]	T_{max} [Nm]
62.3016 CTXR	1:1	55	70	6000	25
62.3016 CTXL	1:1	55	70	6000	25
62.3016 CTXR/2	2:1	55	70	4000	32
62.3016 CTXL/2	2:1	55	70	4000	32

Bestell Nr. Order No.	i	x	x_1	n_{max} [1/min]	T_{max} [Nm]
62.3016L CTXR	1:1	100	125	6000	25
62.3016L CTXL	1:1	100	125	6000	25
62.3016L CTXR/2	2:1	100	125	4000	32
62.3016L CTXL/2	2:1	100	125	4000	32

Schwenkkopf $\pm 105^\circ$

Swivel head $\pm 105^\circ$

Tête pivotante $\pm 105^\circ$

NEWS
 $i = 1:2$

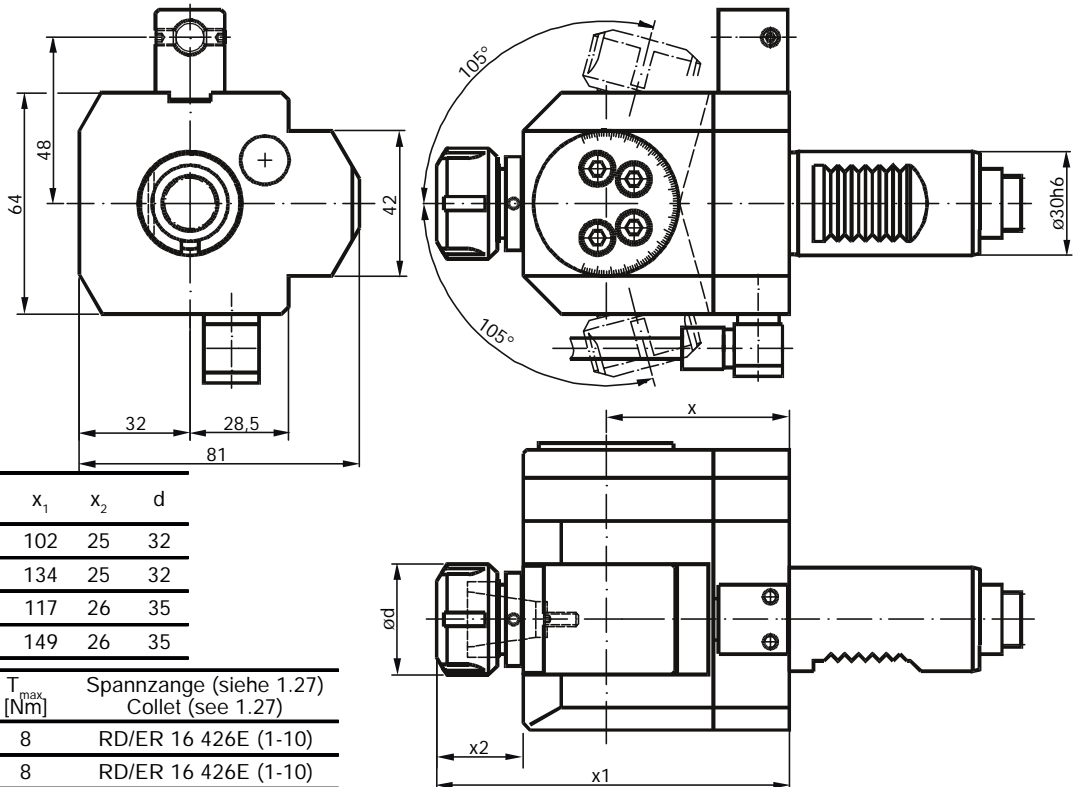

Bestell Nr. Order No.	i	x	x_1	x_2	d
63.3016 CTX/1	1:2	53	102	25	32
63.3016 GT300/1	1:2	85	134	25	32
63.3020 CTX	1:1	60	117	26	35
63.3020 GT300	1:1	92	149	26	35

Bestell Nr. Order No.	n_{max} [1/min]	T_{max} [Nm]	Spannzange (siehe 1.27) Collet (see 1.27)
63.3016 CTX/1	9000	8	RD/ER 16 426E (1-10)
63.3016 GT300/1	9000	8	RD/ER 16 426E (1-10)
63.3020 CTX	5000	16	RD/ER 20 428E (1-13)
63.3020 GT300	5000	16	RD/ER 20 428E (1-13)

Axial Bohr- und
Fräskopf
achsversetzt $i = 2:1 / 3:1$

Axial drilling and
milling head
offset $i = 2:1 / 3:1$

Tête de perçage
et fraisage
 $i = 2:1 / 3:1$

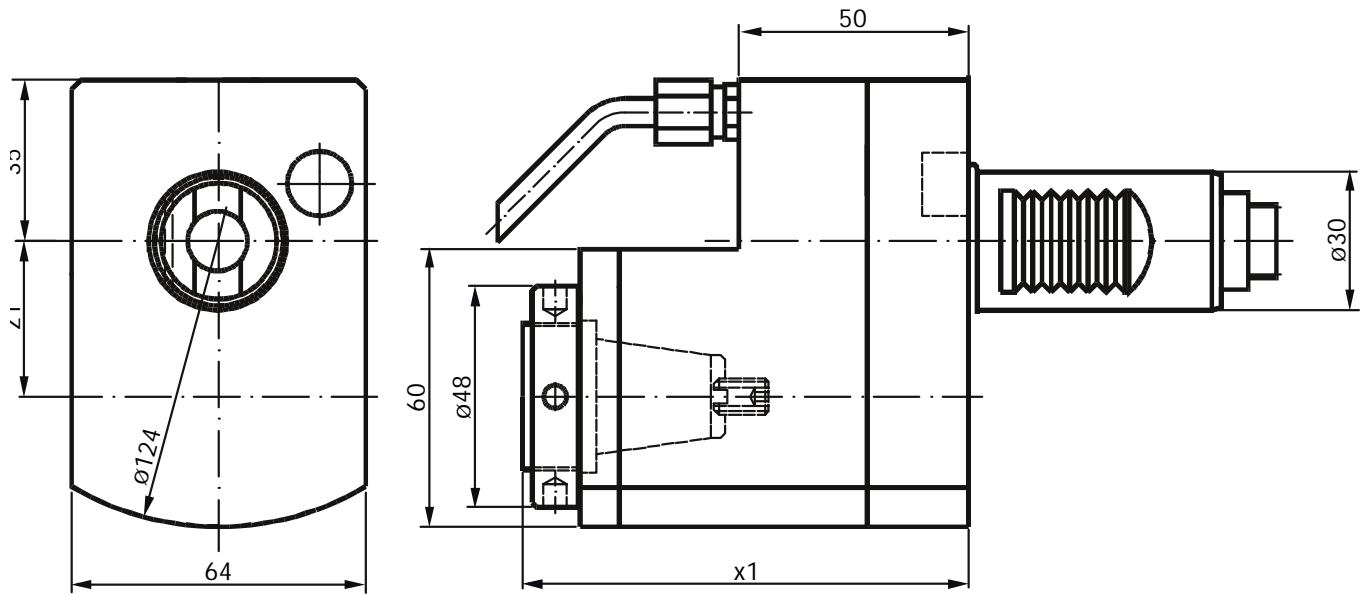

Bestell Nr. Order No.	i	x_1	z_1	n_{max} [1/min]	T_{max} [Nm]	Spannzange (siehe 1.27) Collet (see 1.27)
50.3025 CTXRL/2	2:1	97	31,75	3000	40	RD/ER 25 430 E (2-16)
50.3025 CTXRL/3	3:1	75	67,3	2000	50	RD/ER 25 430 E (2-16)

Axial Bohr- und
Fräskopf
y-verstellbar

Axial drilling and
milling head
y-axis adjustable

Tête de perçage
et fraisage
y-axis adjustable

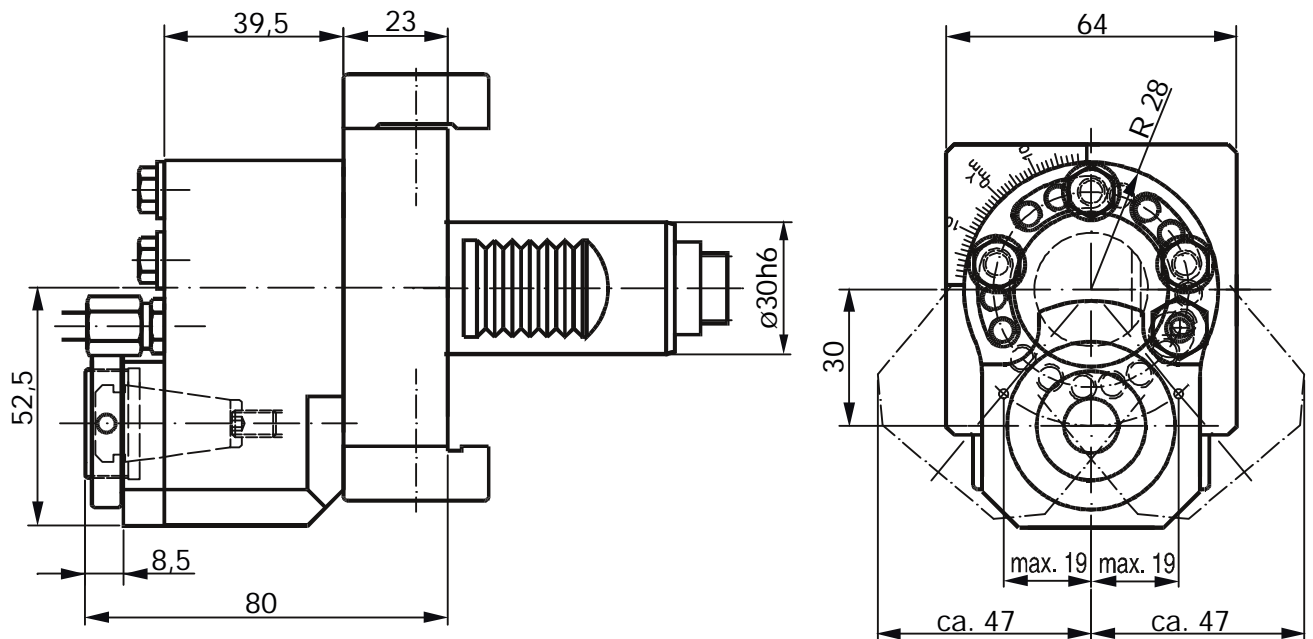

Bestell Nr. Order No.	i	n_{max} [1/min]	T_{max} [Nm]	Spannzange (siehe 1.27) Collet (see 1.27)
56.3016 CTXY30	1:1	6000	25	RD/ER 16 426 E (1-10)

Radial
Scheibenfräserkopf

Radial saw
milling head

Tête de fraisage
radial

Bestell Nr. Order No.	i	d	n_{max} [1/min]	T_{max} [Nm]
64.3016 CTX	3:1	16	2000	40
64.3022 CTX	3:1	22	2000	40

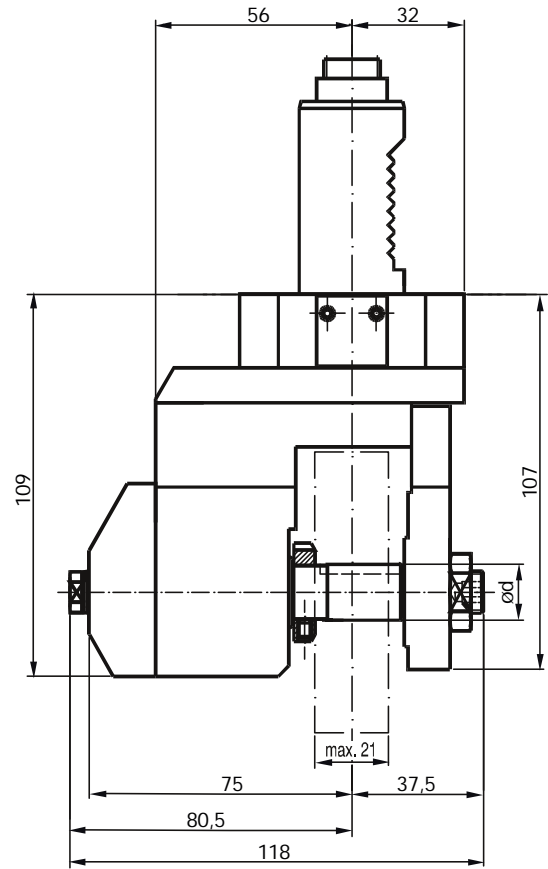
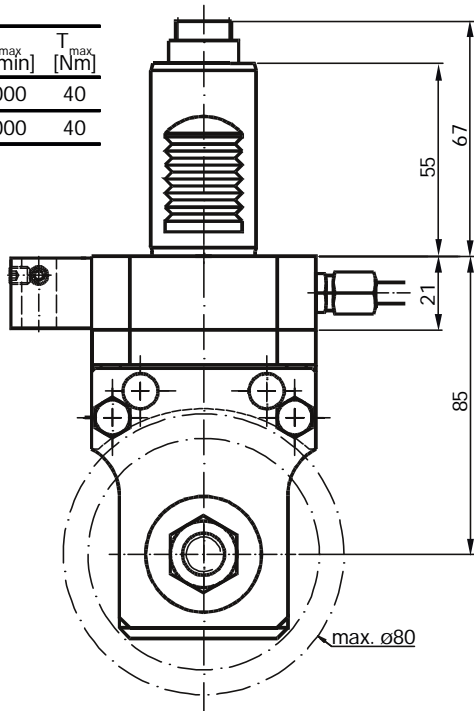

Doppel-Axialkopf
für Maschinen mit
y-Achse

Double axial head
for machines with
y-axis

Double sortie axial
pour machines avec
y-axis

5

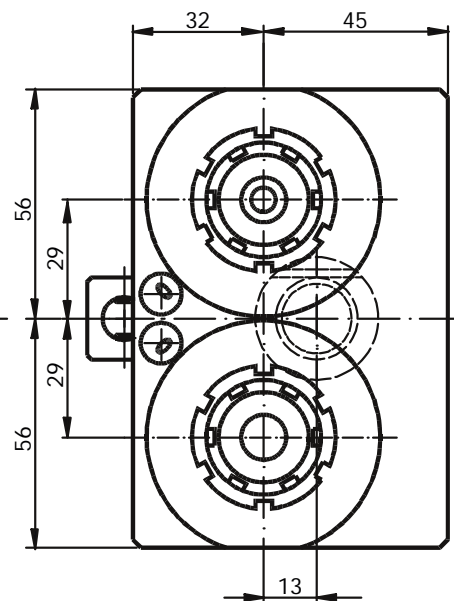
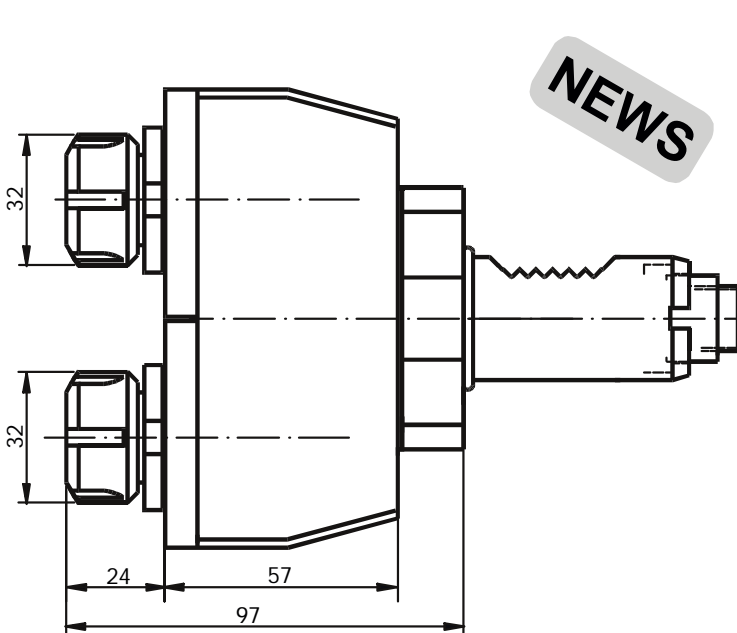

Bestell Nr. Order No.	i	n_{max} [1/min]	T_{max} [Nm]	Spannzange (siehe 1.27) Collet (see 1.27)
40.3016D CXTS01	1:1	5000	16	RD/ER 16 426 E (1-10)

Radial Bohr- und Fräskopf

Radial drilling and milling head

Tête de perçage et fraisage radial

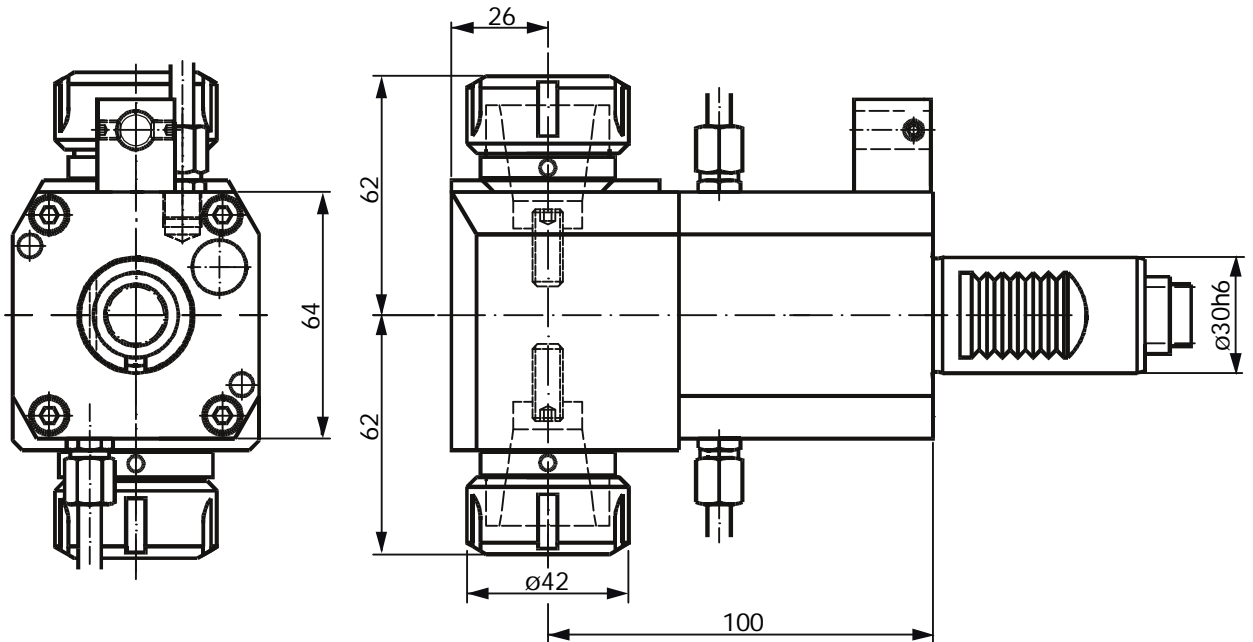

Bestell Nr. Order No.	i	n_{max} [1/min]	T_{max} [Nm]	Spannzangen (siehe 1.27) Collet (see 1.27)
60.3025LD CTX	1:1	5000	25	RD/ER 25 430E (2-16)

Radial Bohr- und Fräskopf zurückgesetzt

Radial drilling and milling head

Tête de perçage et fraisage

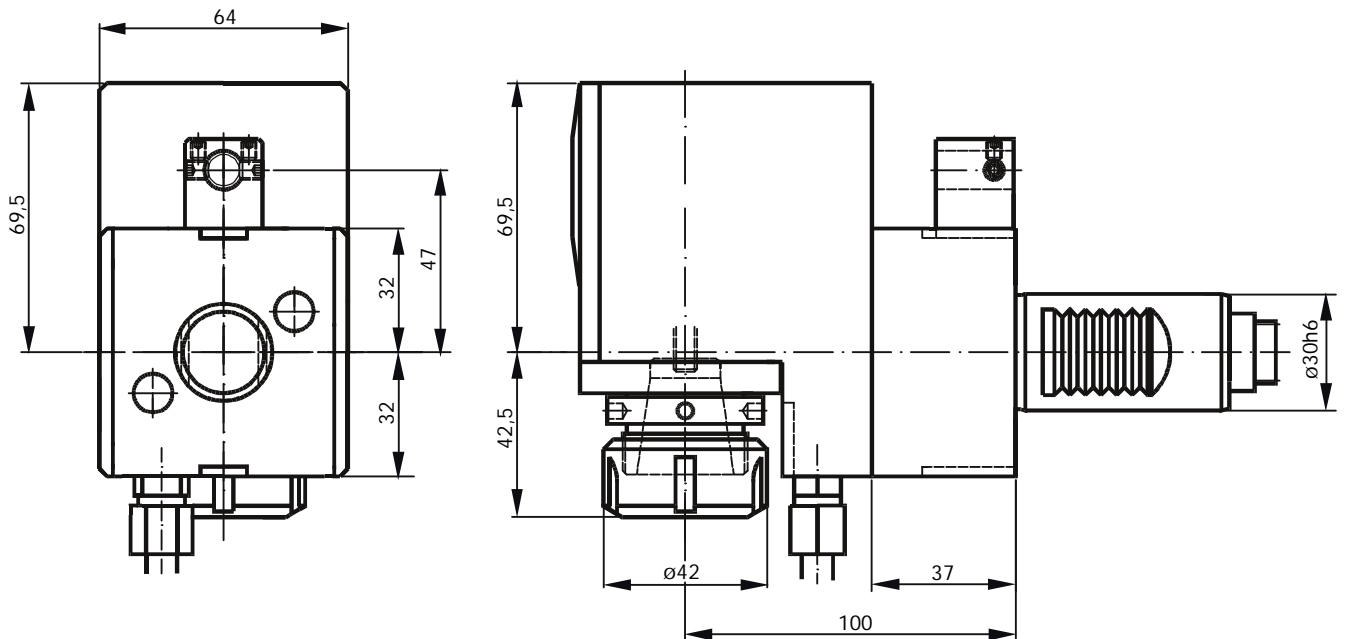

Bestell Nr. Order No.	i	n_{max} [1/min]	T_{max} [Nm]	Spannzangen (siehe 1.27) Collet (see 1.27)
80.3025L CTXRL	1:1	5000	25	RD/ER 25 430E (2-16)



**Statische- und angetriebene Werkzeuge Schaft Ø40 für
Sauter- und Diplomatic-Revolver mit Antrieb nach DIN 5480**

*Static and driven tools with shank Ø40 for Sauter and
Diplomatic turret with coupling according to DIN 5480*

*Porte-outils statiques et motorisés avec VDI40 pour tourelle Sauter
et Douplomatic avec connexion conforme DIN 5480*

Ausgleichhalter für Werkzeughalter DIN 69880 $\varnothing 40$

Adaptor for Toolholder according to DIN 69880 $\varnothing 40$

Adapteur pour outils DIN 69880 $\varnothing 40$

Ausführung L
Links wie gezeichnet
left hand design as shown
à gauche suivant croquis

Ausführung R
spiegelbildlich
right hand design reversed
à droite inversé

Ausführung RL
mit doppelverzahntem
DIN-Schaft (Lizenz Traub)
with doubletoothed DIN shaft
(licence Traub)
universelle pour broche et
contre broche (licence Traub)

Bestell Nr. Order No.	x_1	x_2
WA 4040 CTX L	100	133
WA 4040 CTX R	100	133
WA 4040 CTX RL	100	133
WA 4040 L CTX L	120	153
WA 4040 L CTX R	120	153
WA 4040 L CTX RL	120	153

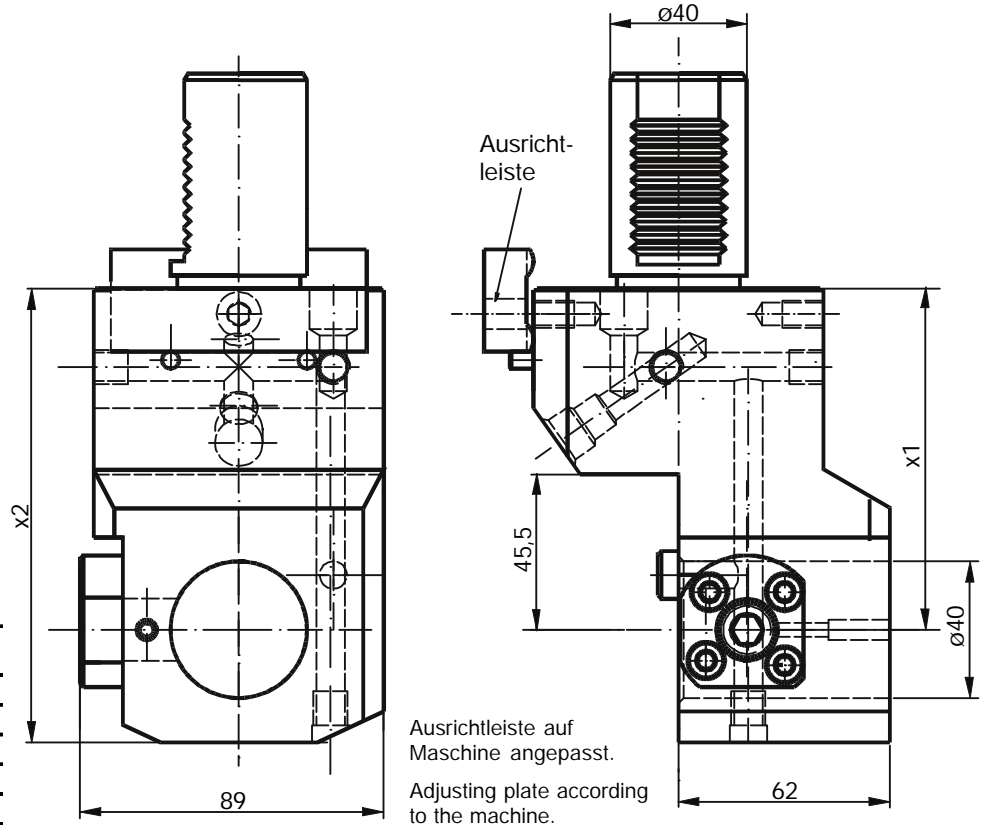

Spannzangen- aufnahme

Collet chuck

Porte pince

Bestell Nr. Order No.	x_1	x_2	d_1	d_2	Spannzange collet / pince
31.4032 CTX L	100	130	3-20	50	320 470 E
31.4032 CTX R	100	130	3-20	50	320 470 E
31.4032 D CTX	100	130	3-20	50	320 470 E doppelseitig
31.4032 L CTX L	120	150	3-20	50	320 470 E
31.4032 L CTX R	120	150	3-20	50	320 470 E
31.4032 LD CTX	120	150	3-20	50	320 470 E doppelseitig

Ausführung L
Links wie gezeichnet
left hand design as shown
à gauche suivant croquis

Ausführung R
spiegelbildlich
right hand design reversed
à droite inversé

Ausführung RL
mit doppelverzahntem DIN-Schaft
(Lizenz Traub)
with doubletoothed DIN shaft
(licence Traub)
universelle pour broche et contre
broche (licence Traub)

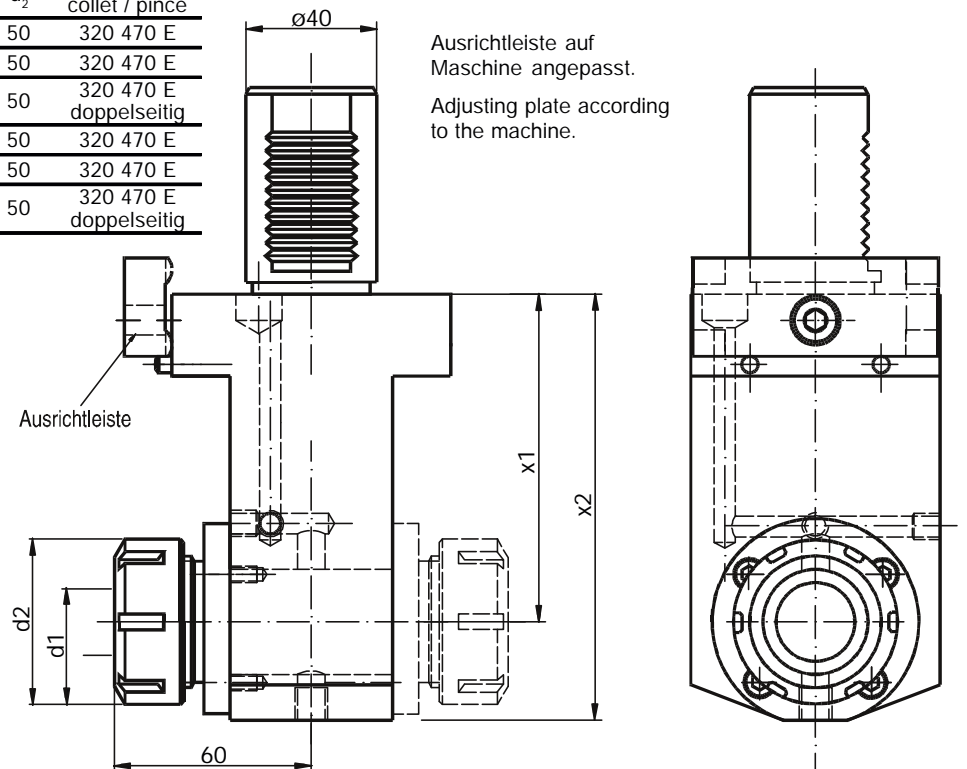

Kombihalter

Combi toolholder

Porte outil combiné

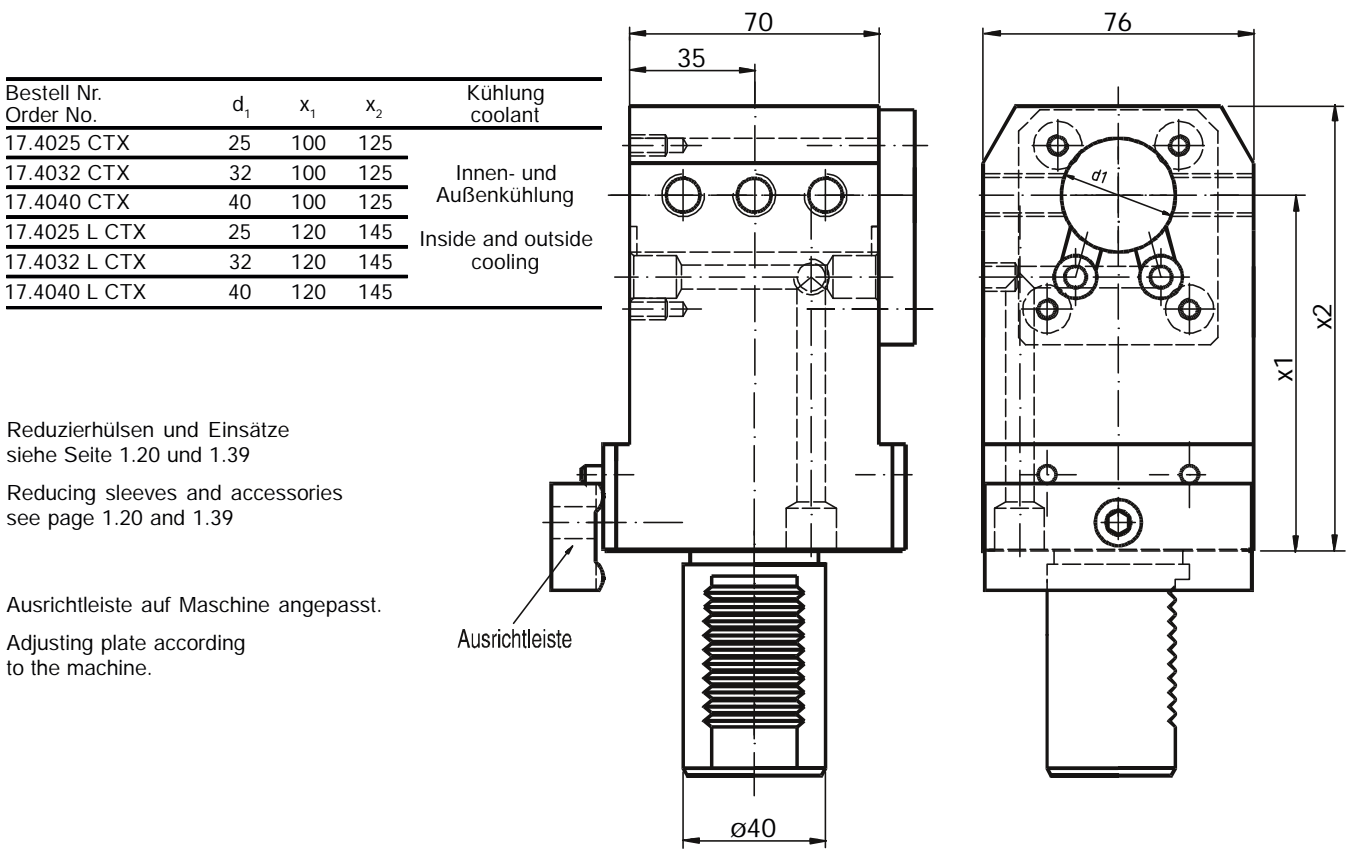

Reduzierhülsen und Einsätze
siehe Seite 1.20 und 1.39

Reducing sleeves and accessories
see page 1.20 and 1.39

Capto-Aufnahme

Capto adaptor

Adapteur de capto

Ausführung L
Links wie gezeichnet
left hand design as shown
à gauche suivant croquis

Ausführung R
spiegelbildlich
right hand design reversed
à droite inversé

Ausführung RL
mit doppelverzahntem DIN-Schaft (Lizenz Traub)
with doubletoothed DIN shaft (licence Traub)
universelle pour broche et contre broche (licence Traub)

ABS - auf Anfrage
ABS - on request

Ausrichtleiste auf Maschine angepasst.
Adjusting plate according to the machine.

Bestell Nr. Order No.	Capto	x ₁
19.40C4 CTX L	C4	100
19.40C4 CTX R	C4	100
19.40C4 CTX RL	C4	100
19.40C4 L CTX L	C4	120
19.40C4 L CTX R	C4	120
19.40C4 L CTX RL	C4	120

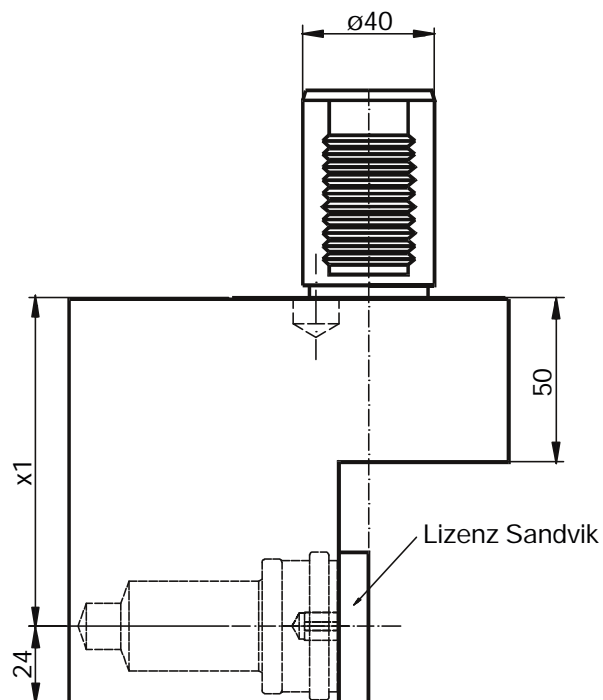

Drehhalter Capto

Turning tool holder
Capto

Porte outil de
Capto

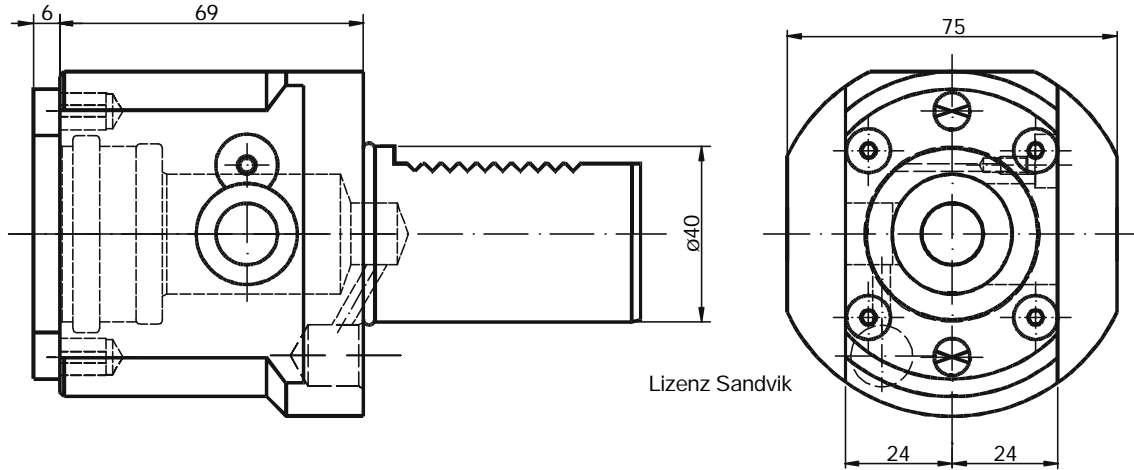

Bestell Nr. Order No.	
19.40C4L75L	Klemmung links Clamping wedge left hand
19.40C4L75R	Klemmung wie gezeichnet Clamping wedge as shown

ABS - auf Anfrage
ABS - on request

**Abstechhalter
höhenverstellbar**

Infeed toolholder
height adjustable

Porte outil
plongée, réglable

5

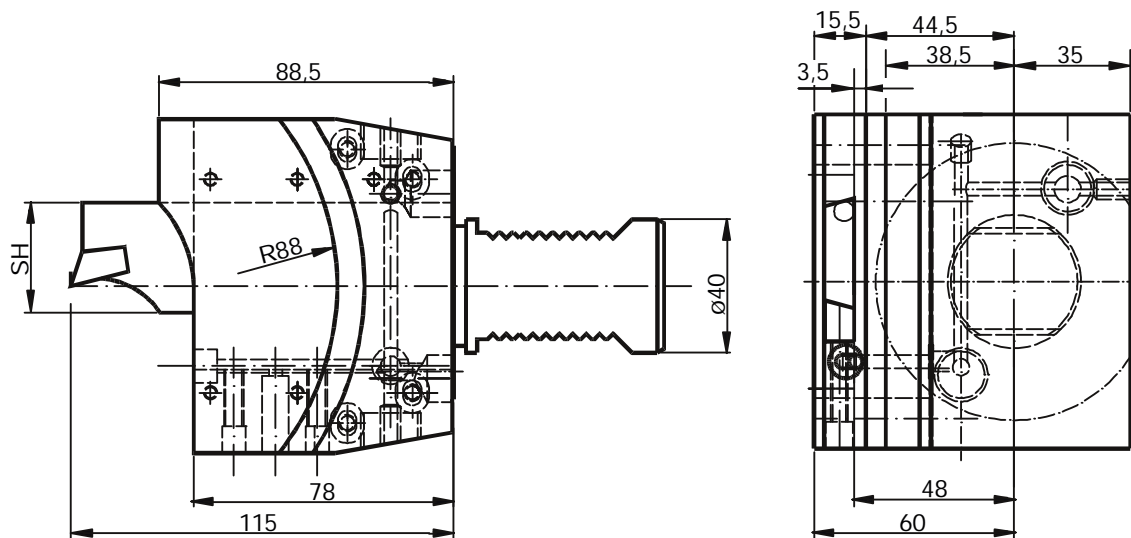

Bestell Nr. Order No.	SH
32.4026 WT250 RL	26
32.4026 WT250 RL ÜK	26
32.4032 WT250 RL	32
32.4032 WT250 RL ÜK	32

RL ÜK wie gezeichnet / as shown
RL Schneide spiegelbildlich /
cutting edge reversed

Plandrehhalter

Facing holder

Porte outil carré

Bestell Nr.
Order No.
5.4025 G400 RL

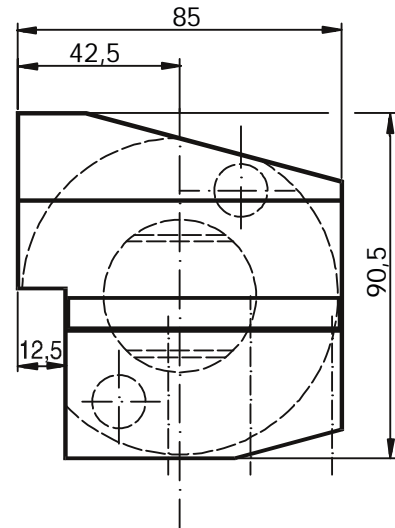
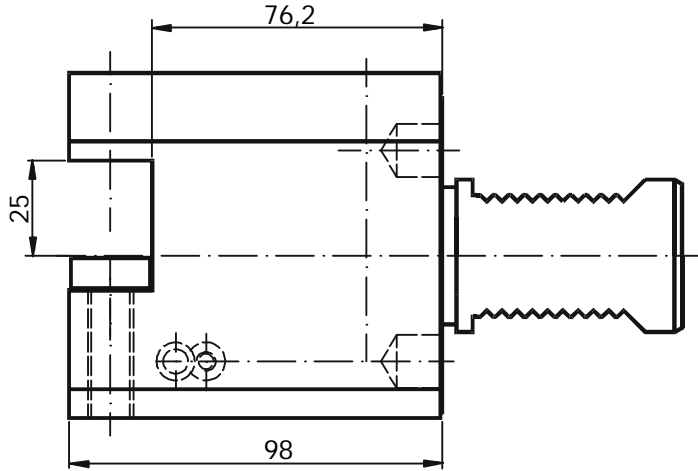

Plandrehhalter

Facing holder

Porte outil carré

Bestell Nr.
Order No.
6.4025 G400 RL

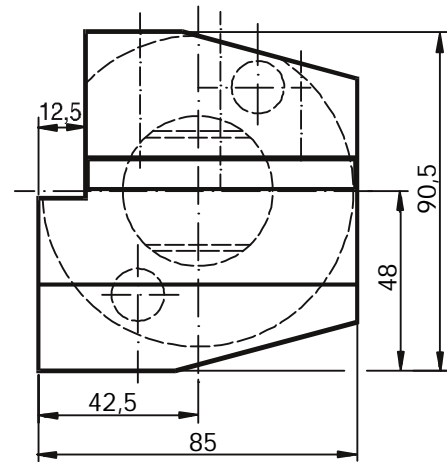
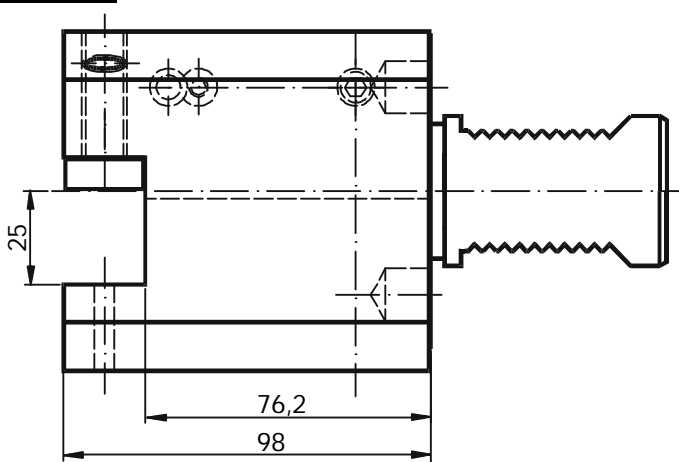

Außendrehhalter

OD-holder

Bestell Nr. Order No.	
1.4025/20	rechts / right hand tool / à droite
2.4025/20 STR	rechts / right hand tool / à droite modifiziert für Sternrevolver / modified for star turret
3.4025/20 STR	links / left hand tool / à gauche modifiziert für Sternrevolver / modified for star turret
4.4025/20	links / left hand tool / à gauche

Zeichnungen siehe Kapitel 1, Seite 1.6 und 1.7
Drawings see chapter 1, page 1.6 and 1.7
Regardez chapitre 1, page 1.6 et 1.7

Axial Bohr-
und Fräskopf

Axial drilling
and milling head

Tête de perçage
et fraisage axial

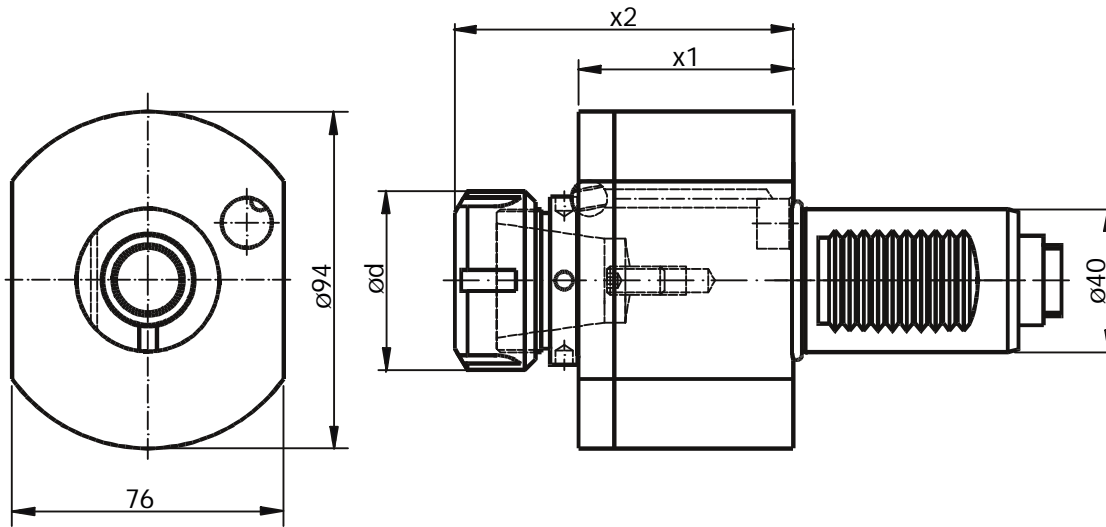

Bestell Nr. Order No.	i	x ₁	x ₂	ød	n _{max} [1/min]	T _{max} [Nm]	Spannzange (Seite 1.27) Collet (Page 1.27)
40.4032 K CTX	1:1	60	95	50	5000	50	320 470 E (3-20)
40.4032 CTX	1:1	76	111	50	5000	50	320 470 E (3-20)
40.4025 K CTX	1:1	60	94	42	5000	50	250 430 E (2-16)
40.4025 CTX	1:1	76	110	42	5000	50	250 430 E (2-16)

Axial Bohr-
und Fräskopf
Weldon / Whistle notch

Axial drilling and
milling head
Weldon / Whistle notch

Tête de perçage
et fraisage axial
Weldon / Whistle notch

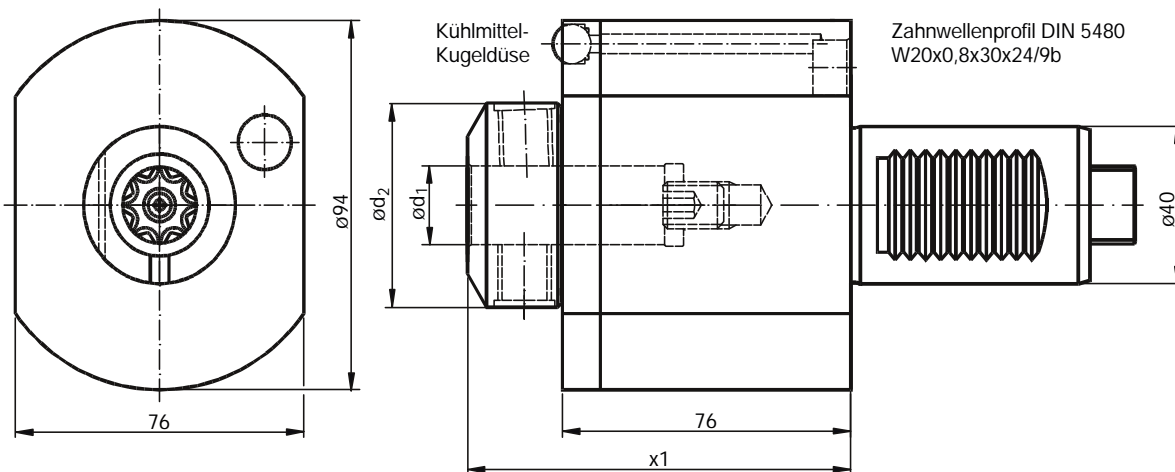

Bestell Nr. Order No.	i	ød ₁	ød ₂	x ₁	n _{max} [1/min]	T _{max} [Nm]
40.4016 WN CTX	1:1	16	48	101	5000	50
40.4020 WN CTX	1:1	20	52	101	5000	50
40.4025 WN CTX	1:1	25	60	109	5000	50

Axial Fräskopf

Axial milling head

Tête de fraisage axial

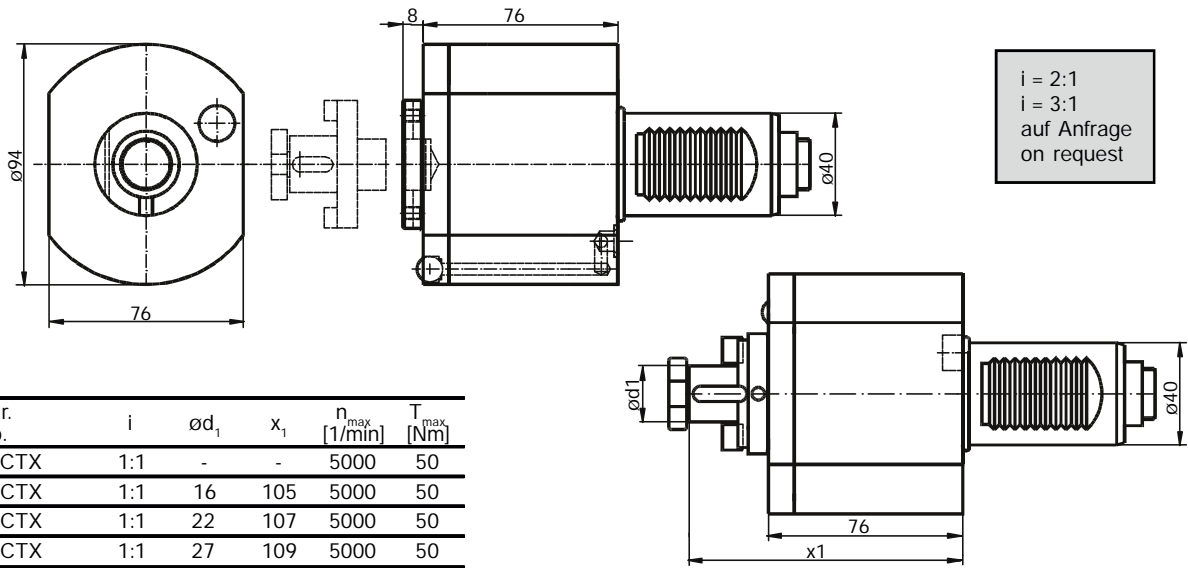

Bestell Nr. Order No.	i	$\varnothing d_1$	x_1	n_{\max} [1/min]	T_{\max} [Nm]
42.4000 CTX	1:1	-	-	5000	50
42.4016 CTX	1:1	16	105	5000	50
42.4022 CTX	1:1	22	107	5000	50
42.4027 CTX	1:1	27	109	5000	50

Fräsdorneinsatz
für 42.4000 ... 62.4000

Arbor insert
for 42.4000 ... 62.4000

Adapteur de fraisage
pour 42.4000 ... 62.4000

Bestell Nr. Order No.	d	x
501.0507	13	24
501.0510	16	29
501.0520	22	31
501.0530	27	33

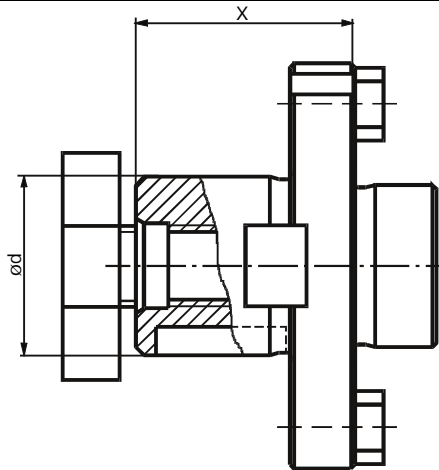

Axial Pendel-
Werkzeugaufnahme

Axial Floating
adaptor

Axial flottant
adapteur

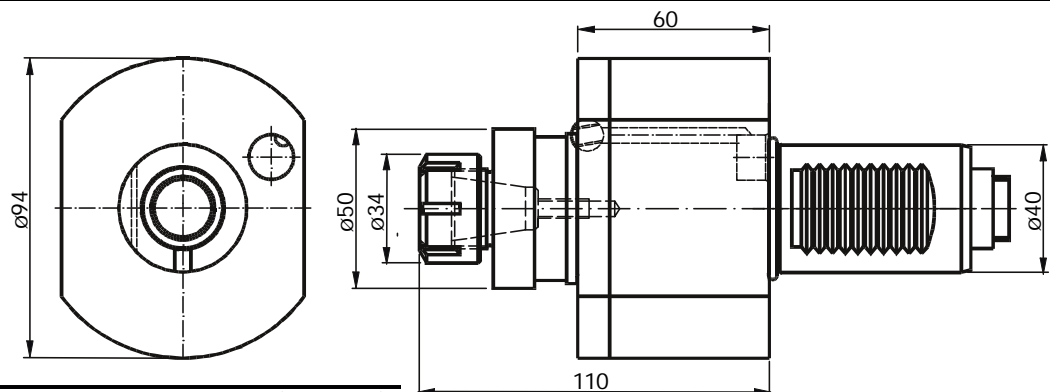

Bestell Nr. Order No.	i	n_{\max} [1/min]	T_{\max} [Nm]	Spannzangen (Seite 1.27) Collet (Page 1.27)
43.4020 CTX	1:1	5000	20	200 428 E (1-13)

Axial Bohr-
und Fräskopf

Axial drilling and
milling head

Tête de perçage
et fraisage axial

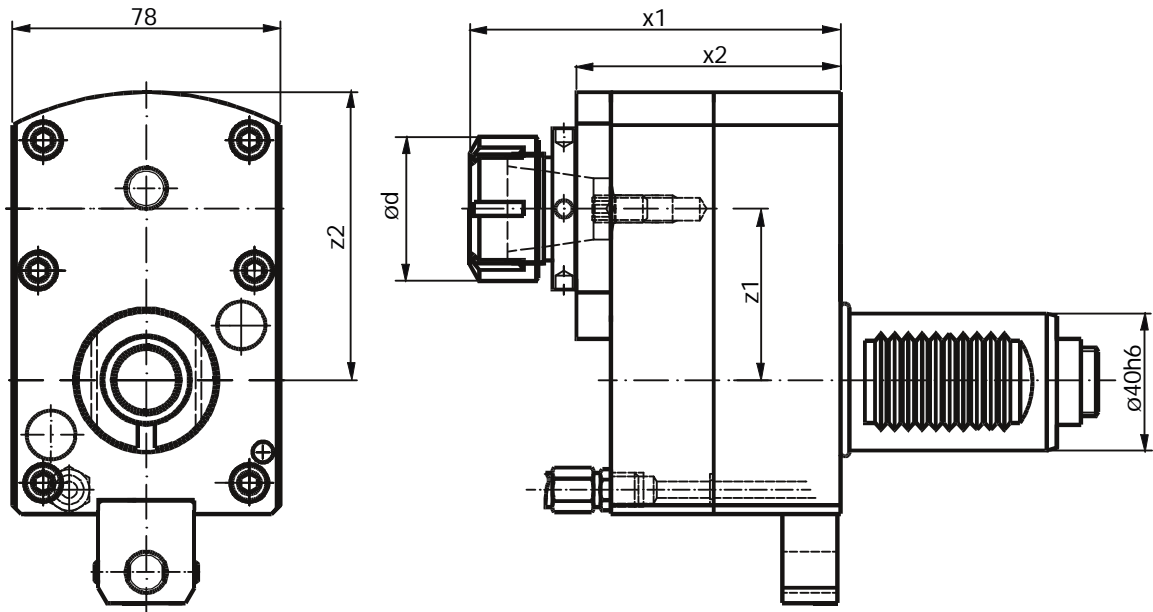

Bestell Nr. Order No.	i	n_{max} [1/min]	T_{max} [Nm]	x_1	x_2	z_1	z_2	Spannzangen (Seite 1.27) Collet (Page 1.27)
50.4025 CTX RL/1	1:2	10000	20	110	77	50	84	250 430 E (2-16)
50.4032 CTX RL/2	2:1	3000	80	110	77	50	84	320 470 E (3-20)
50.4032 CTX RL/3	3:1	2000	120	138	98	55,5	104	320 470 E (3-20)
50.4040 CTX RL/3	3:1	2000	120	140	98	55,5	104	400 472 E (4-26)

Axial Bohr- und Fräskopf,
y-verstellbar

Axial drilling and milling
head, y-axis adjustable

Tête de perçage et fraisage,
regulable y-axis

5

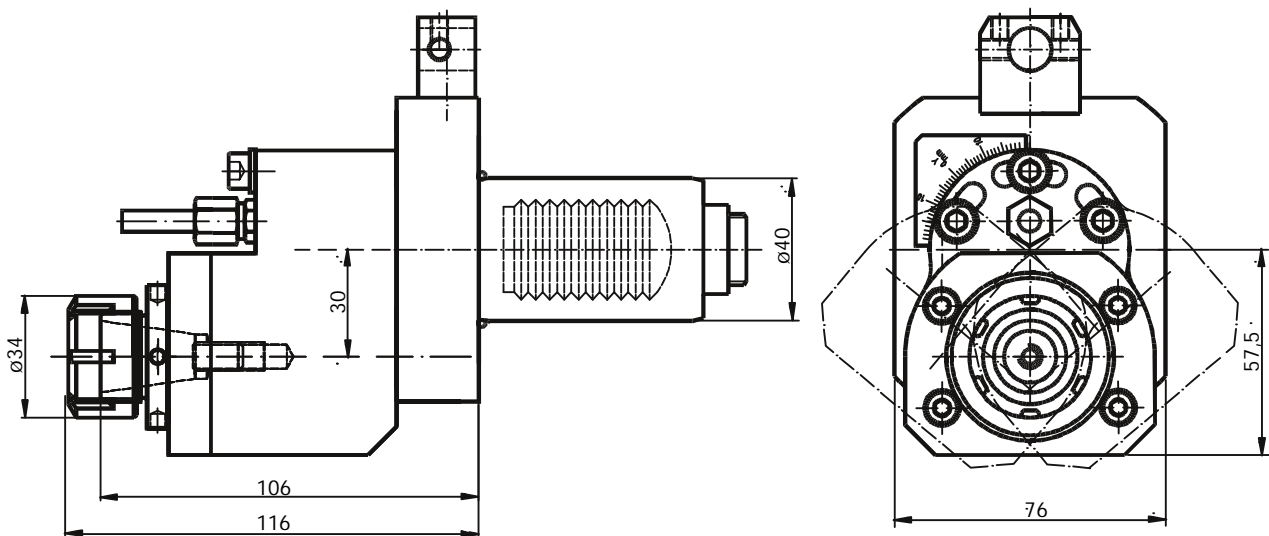

Bestell Nr. Order No.	i	n_{max} [1/min]	T_{max} [Nm]	y-Axis	Spannzangen (Seite 1.27) Collet (Page 1.27)
56.4020 CTX	1:1	5000	25	± 30	ER 20 428 E (1-13)

Radial Bohr- und Fräskopf

Radial drilling and milling head

Tête de perçage et fraisage radial

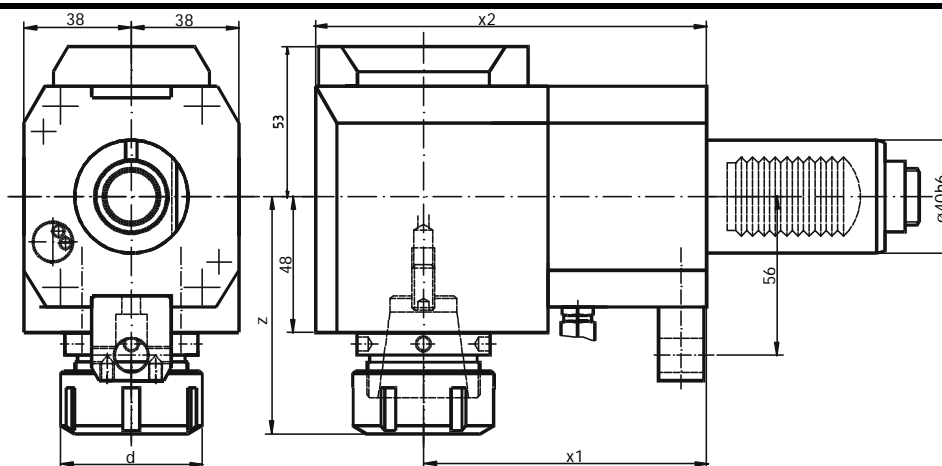

Bestell Nr. Order No.	i	x ₁	x ₂	z ₁	d	n _{max} [1/min]	T _{max} [Nm]	Spannzangen (Seite 1.27) Collet (Page 1.27)
60.4025 CTX L	1:1	100	138	81	42	5000	50	250 430 E (2-16)
60.4025 CTX R	1:1	100	138	81	42	5000	50	250 430 E (2-16)
60.4025 CTX RL	1:1	100	138	81	42	5000	50	250 430 E (2-16)
60.4032 CTX L	1:1	100	138	85	50	5000	50	320 470 E (3-20)
60.4032 CTX R	1:1	100	138	85	50	5000	50	320 470 E (3-20)
60.4032 CTX RL	1:1	100	138	85	50	5000	50	320 470 E (3-20)
60.4025 CTX L/1	1:2	100	138	81	42	10000	50	250 430 E (2-16)
60.4025 CTX R/1	1:2	100	138	81	42	10000	50	250 430 E (2-16)
60.4025 CTX RL/1	1:2	100	138	81	42	10000	50	250 430 E (2-16)
60.4032 CTX L/2	2:1	100	138	93	50	3000	80	320 470 E (3-20)
60.4032 CTX R/2	2:1	100	138	93	50	3000	80	320 470 E (3-20)
60.4032 CTX RL/2	2:1	100	138	93	50	3000	80	320 470 E (3-20)
60.4025 L CTX L	1:1	120	158	81	42	5000	50	250 430 E (2-16)
60.4025 L CTX R	1:1	120	158	81	42	5000	50	250 430 E (2-16)
60.4025 L CTX RL	1:1	120	158	81	42	5000	50	250 430 E (2-16)
60.4032 L CTX L	1:1	120	158	85	50	5000	50	320 470 E (3-20)
60.4032 L CTX R	1:1	120	158	85	50	5000	50	320 470 E (3-20)
60.4032 L CTX RL	1:1	120	158	85	50	5000	50	320 470 E (3-20)
60.4025 L CTX L/1	1:2	120	158	81	42	10000	50	250 430 E (2-16)
60.4025 L CTX R/1	1:2	120	158	81	42	10000	50	250 430 E (2-16)
60.4025 L CTX RL/1	1:2	120	158	81	42	10000	50	250 430 E (2-16)
60.4032 L CTX L/2	2:1	120	158	93	50	3000	80	320 470 E (3-20)
60.4032 L CTX R/2	2:1	120	158	93	50	3000	80	320 470 E (3-20)
60.4032 L CTX RL/2	2:1	120	158	93	50	3000	80	320 470 E (3-20)

Mit OTSS-Leiste NG 200 statt CTX (Schutzrecht angemeldet)

With OTSS-plate write NG200 instead of CTX

Ausführung L
Links wie gezeichnet
Left hand design as shown
à gauche suivant croquis

Ausführung R
spiegelbildlich
right hand design reversed
à droite inversé

Ausführung RL
mit doppelverzahntem
DIN-Schaft (Lizenz Traub)
with doubletoothed
DIN shaft (licence Traub)
universelle pour broche et
contre broche (licence Traub)

Radial Bohr- und Fräskopf

Radial drilling and milling head

Tête de perçage et fraisage radial

Mit OTSS-Leiste NG 200 statt CTX (Schutzrecht angemeldet)
With OTSS-plate write NG200 instead of CTX

Bestell Nr. Order No.	i	x ₁	x ₂
60.4032 D CTX	1:1	100	137
60.4032 LD CTX	1:1	120	157

Bestell Nr. Order No.	n _{max} [1/min]	T _{max} [Nm]	Spannzangen (Seite 1.27) Collet (Page 1.27)
60.4032 D CTX	5000	50	320 470 E (3-20)
60.4032 LD CTX	5000	50	320 470 E (3-20)

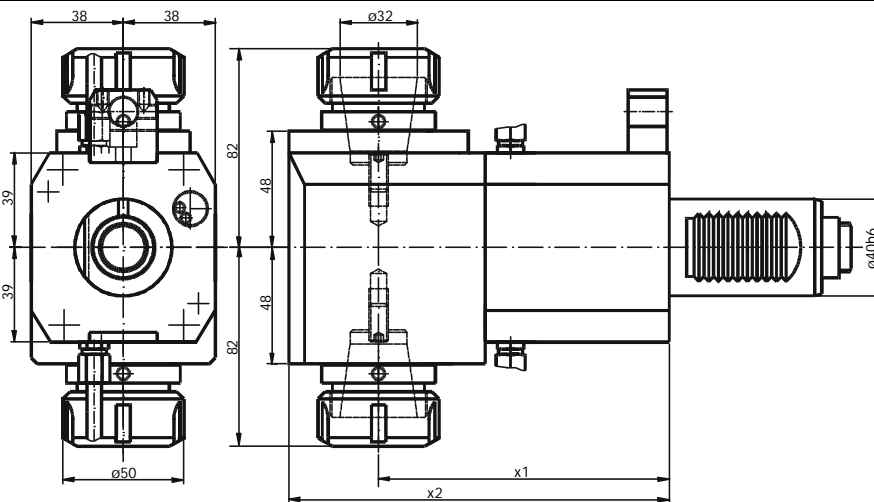

Radial Bohr- und Fräskopf Weldon / Whistle notch

Radial drilling and milling head Weldon / Whistle notch

Tête de perçage et fraisage radial Weldon / Whistle notch

Mit OTSS-Leiste NG 200 statt CTX (Schutzrecht angemeldet)
With OTSS-plate write NG200 instead of CTX

ABS + Capto auf Anfrage.
ABS and Capto on request.

Reduzierbuchsen
Reducing sleeves

Bestell Nr.
Order No.

28.2016 WN	20/16
28.2012 WN	20/12
28.2010 WN	20/10
28.2008 WN	20/08

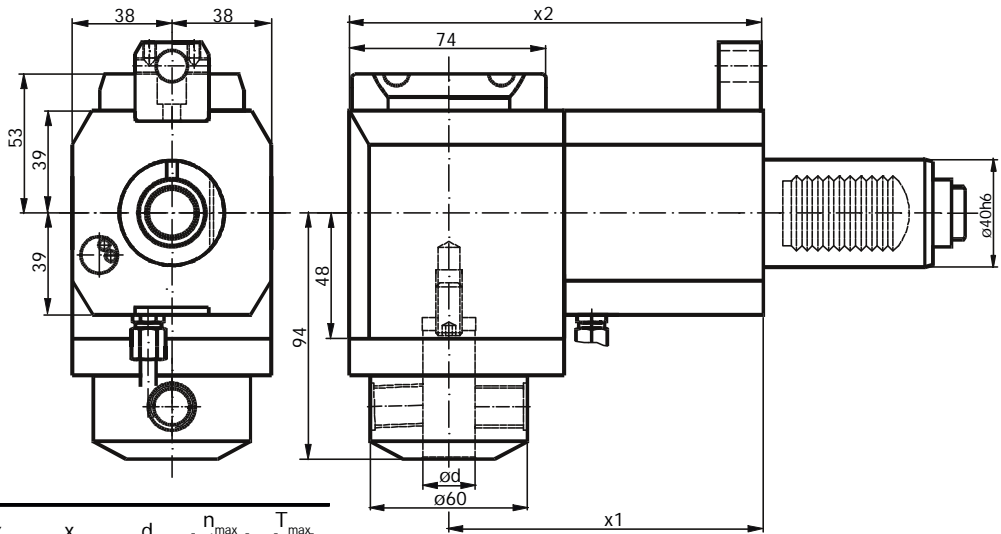

Bestell Nr. Order No.	i	x ₁	x ₂	d	n _{max} [1/min]	T _{max} [Nm]
60.4020 WN CTX L	1:1	100	138	20	5000	50
60.4020 WN CTX R	1:1	100	138	20	5000	50
60.4020 WN CTX RL	1:1	100	138	20	5000	50
60.4020 WN L CTX L	1:1	120	158	20	5000	50
60.4020 WN L CTX R	1:1	120	158	20	5000	50
60.4020 WN L CTX RL	1:1	120	158	20	5000	50
60.4020 WN CTX L/2	2:1	100	138	20	3000	80
60.4020 WN CTX R/2	2:1	100	138	20	3000	80
60.4020 WN CTX RL/2	2:1	100	138	20	3000	80
60.4020 WN L CTX L/2	2:1	120	158	20	3000	80
60.4020 WN L CTX R/2	2:1	120	158	20	3000	80
60.4020 WN L CTX RL/2	2:1	120	158	20	3000	80

Ausführung L
Links wie gezeichnet
Left hand design as shown
à gauche suivant croquis

Ausführung R
spiegelbildlich
right hand design reversed
à droite inversé

Ausführung RL
mit doppelverzahntem DIN-Schaft (Lizenz Traub)
with doubletoothed DIN shaft (licence Traub)
universelle pour broche et contre broche (licence Traub)

Radial Fräskopf

Radial milling head

Tête de fraisage radial

Mit OTSS-Leiste NG 200 statt CTX (Schutzrecht angemeldet)
With OTSS-plate write NG200 instead of CTX

Einsatz siehe Seite 5.76.2
Inserts see page 5.76.2

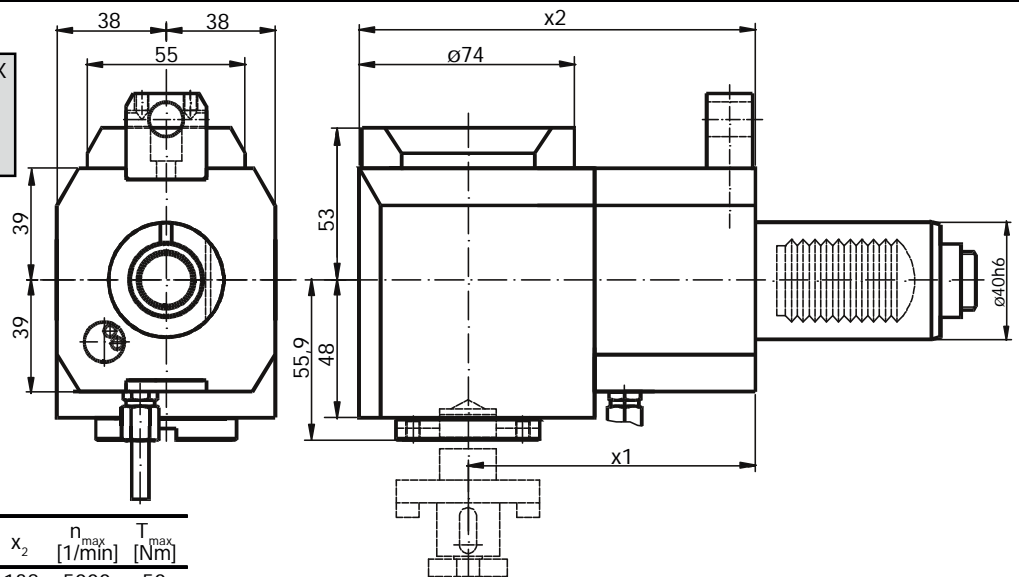

Bestell Nr. Order No.	i	x ₁	x ₂	n _{max} [1/min]	T _{max} [Nm]
62.4000 CTX L	1:1	100	138	5000	50
62.4000 CTX R	1:1	100	138	5000	50
62.4000 CTX RL	1:1	100	138	5000	50
62.4000 L CTX L	1:1	120	158	5000	50
62.4000 L CTX R	1:1	120	158	5000	50
62.4000 L CTX RL	1:1	120	158	5000	50
62.4000 ...	2:1	Auf Anfrage / on request sur demande			

Ausführung R
spiegelbildlich
right hand design reversed
à droite inversé

Ausführung L
Links wie gezeichnet
left hand design as shown
à gauche suivant croquis

Ausführung RL
mit doppelverzahntem DIN-Schaft (Lizenz Traub)
with doubletoothed DIN shaft (licence Traub)
universelle pour broche et contre broche (licence Traub)

Radial Bohr-
und Fräskopf,
zurückgesetzt

Radial drilling
and milling head,
offset

Tête de perçage
et fraiseage radial

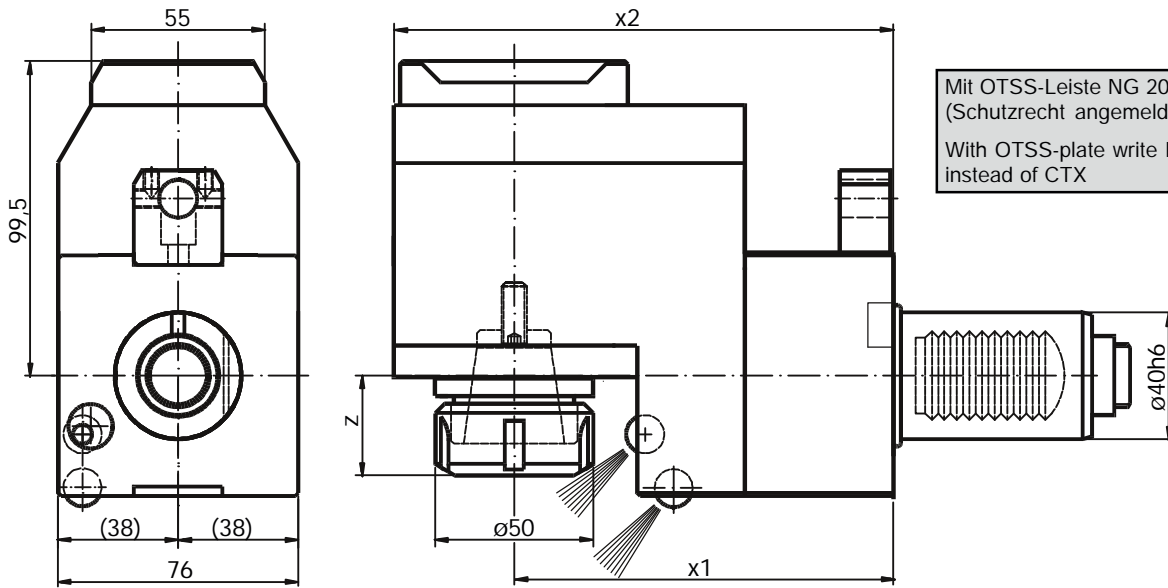

Mit OTSS-Leiste NG 200 statt CTX
(Schutzrecht angemeldet)
With OTSS-plate write NG200
instead of CTX

Bestell Nr. Order No.	i	x ₁	x ₂	z	d	n _{max} [1/min]	T _{max} [Nm]	Spannzangen (Seite 1.27) Collet (Page 1.27)
80.4032 CTX L	1:1	100	138	31	50	5000	50	320 470 E (3-20)
80.4032 CTX R	1:1	100	138	31	50	5000	50	320 470 E (3-20)
80.4032 CTX RL	1:1	100	138	31	50	5000	50	320 470 E (3-20)
80.4032 CTX L/2	2:1	100	138	43	50	3000	80	320 470 E (3-20)
80.4032 CTX R/2	2:1	100	138	43	50	3000	80	320 470 E (3-20)
80.4032 CTX RL/2	2:1	100	138	43	50	3000	80	320 470 E (3-20)
80.4032 L CTX L	1:1	120	158	31	50	5000	50	320 470 E (3-20)
80.4032 L CTX R	1:1	120	158	31	50	5000	50	320 470 E (3-20)
80.4032 L CTX RL	1:1	120	158	31	50	5000	50	320 470 E (3-20)
80.4032 L CTX L/2	2:1	120	158	43	50	5000	50	320 470 E (3-20)
80.4032 L CTX R/2	2:1	120	158	43	50	5000	50	320 470 E (3-20)
80.4032 L CTX RL/2	2:1	120	158	43	50	5000	50	320 470 E (3-20)
80.4032 CTX R/3	3:1	113	159	50	50	2000	120	320 470 E (3-20)
80.4032 CTX L/3	3:1	113	159	50	50	2000	120	320 470 E (3-20)
80.4032 CTX RL/3	3:1	113	159	50	50	2000	120	320 470 E (3-20)

Ausführung R
spiegelbildlich
right hand design reversed
à droite inversé

Ausführung L
Links wie gezeichnet
left hand design as shown
à gauche suivant croquis

Ausführung RL
mit doppelverzahntem DIN-Schaft
(Lizenz Traub)
with doubletoothed DIN shaft
(licence Traub)
universelle pour broche et contre broche
(licence Traub)

Schwenkkopf
± 105°

Swivel head
± 105°

Tête de pivotante
± 105°

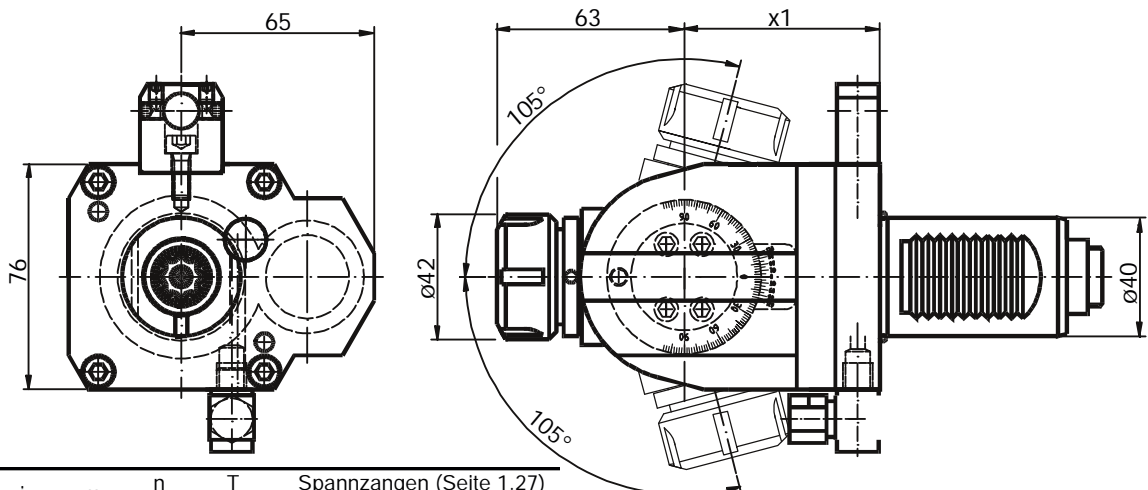

Bestell Nr. Order No.	i	x ₁	n _{max} [1/min]	T _{max} [Nm]	Spannzangen (Seite 1.27) Collet (Page 1.27)
63.4025 CTX	1:1	66	5000	20	250 430 E
63.4025 L CTX	1:1	87	5000	20	250 430 E





Werkzeuge für Mazak / Okuma / Mori Seiki Maschinen

Tools for Mazak / Okuma / Mori Seiki machines

Porte-outils pour machines Mazak / Mori Seiki

Werkzeuge für Mazak / Mori Seiki Maschinen
Tools for Mazak / Mori Seiki machines
Porte-outils pour machines Mazak / Mori Seiki

			Form	Page
Mazak Quick Turn, Super Quick Turn, Multiplex, Nexus, Hyper Quadrex	Mazak Quick Turn, Super Quick Turn, Multiplex, Nexus, Hyper Quadrex	Mazak Quick Turn, Super Quick Turn, Multiplex, Nexus, Hyper Quadrex		6.1 - 6.28
Okuma LT10, LT200	Okuma LT10, LT200	Okuma LT10, LT200		6.40 - 6.44
Okuma LB2000, LB3000	Okuma LB2000, LB3000	Okuma LB2000, LB3000		6.50.1 - 6.50.11
Mori Seiki ZT1000	Mori Seiki ZT1000	Mori Seiki ZT1000		6.80 - 6.81.4
Mori Seiki SL200	Mori Seiki SL200	Mori Seiki SL200		6.72 - 6.73.11
Mori Seiki NL1500, NL2000, NL2500, NL3000	Mori Seiki NL1500, NL2000, NL2500, NL3000	Mori Seiki NL1500, NL2000, NL2500, NL3000		6.78.1 - 6.79.5
Mori Seiki ZT1000, ZT1500, MT1500	Mori Seiki ZT1000, ZT1500, MT1500	Mori Seiki ZT1000, ZT1500, MT1500		6.80.1 - 6.81.4



**Statische- und angetriebene Werkzeuge für Mazak
QT/SQT/QTN/MP/Quadrex Maschinen**

Static and driven tools for Mazak QT/SQT/QTN/MP/Quadrex machines

Porte-outils statiques et motorisés pour machines

Mazak QT/SQT/QTN/MP/Quadrex

Kombihalter

Combiholder

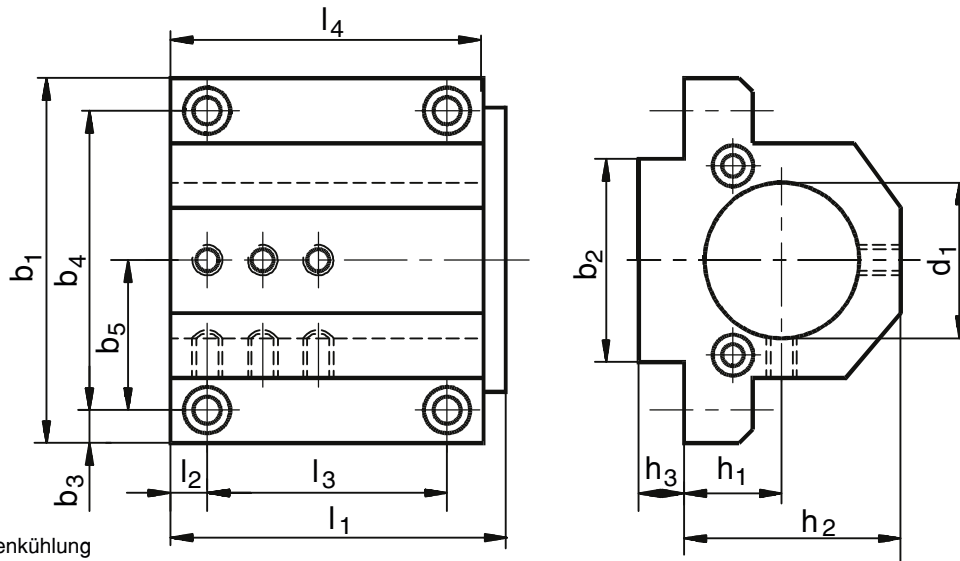

Für Innen- und Außenkühlung
For internal and external cooling

Maschinentyp	Nr. / No.	d ₁	h ₁	h ₂	h ₃	b ₁	b ₂	b ₃	b ₄	b ₅	l ₁	l ₂	l ₃	l ₄
QT8-8D / QT8N-8D	QT 801	ø30	25	52	7	95	38	9,5	76	36	71	15	45	67
QTN10-8D	QT 821	ø25	25	52	7	95	38	9,5	76	36	71	15	45	67
QT10-8D	QT 1001	ø40	25	54	7,5	114	38	10	94	47	82	10	60	78
QT15-8D / QT15N-8D QT18N-8D / QTN20-8D QT20HP-8D / Dual Turn 20 SQT200-12D / SQT250-12D	QT 1501	ø40	50	80	7,5	114	38	10	94	47	100	10	60	95
QT15-12D / QT15N-12D QT18N-12D / QT20N-12D QT20HP-12D	QT 1541	ø40	25	57	7,5	114	38	10	94	47	100	10	60	94
QT20N-8D / QT25-8D	QT 2001	ø50	35	72,5	7,5	132	48	14	104	52	103	14	72	98
QT28-12D / QT28N-12D / QT30N-12D / QTN30-12D	QT 2801	ø50	55	90	7	128	48	12	104	52	111	34	57	106

Mit (With) ABS-/UTS-/Capto-/Zoll-ø/Sonder-ø auf Anfrage (on request).

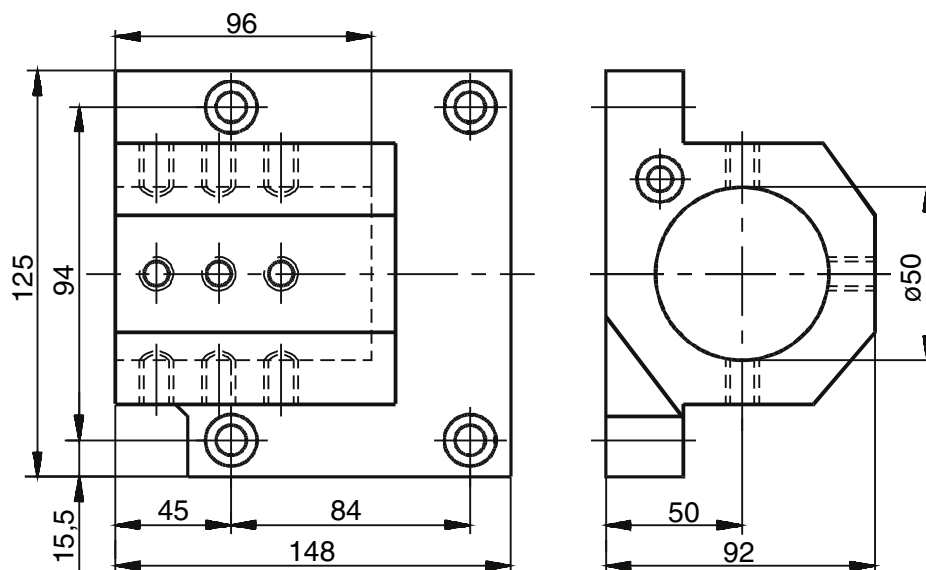

Maschinentyp	Nr. / No.
QT35-12D QT35N-12D QTN40-12D	QT 3501

Für Innen- und Außenkühlung
For internal and external cooling

Grundhalter

Für Spannzangenhalter,
Gewindebohrhalter und
Pendelhalter

Basic toolholder

For collet chuck, tap cutting-
holder and floating reamer-
holder

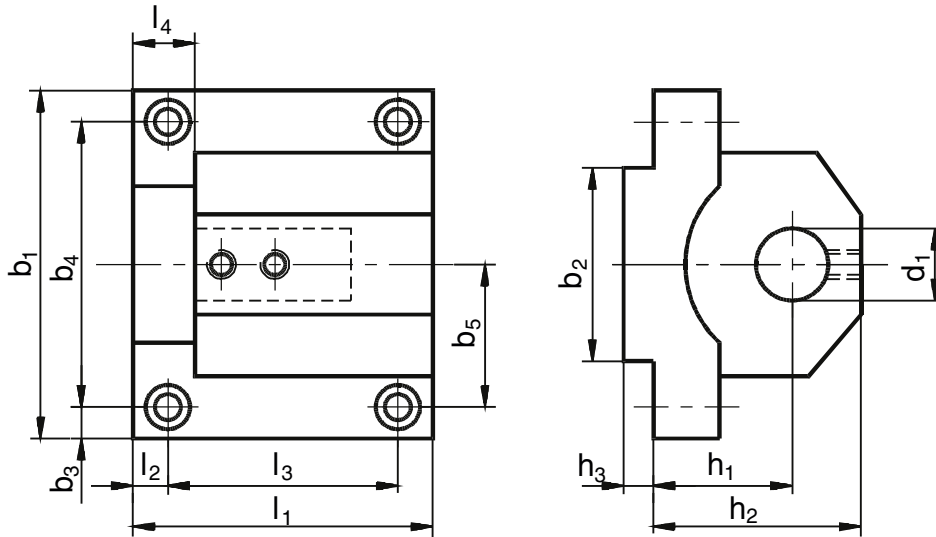

Für Innen- und Außenkühlung
For internal and external cooling

Maschinentyp	Nr. / No.	d ₁	h ₁	h ₂	h ₃	b ₁	b ₂	b ₃	b ₄	b ₅	l ₁	l ₂	l ₃	l ₄
QT8-8D / QT8N-8D / QTN10-8D	QT 800	25	25	52	7	95	38	9,5	76	36	71	15	45	16
QT10-8D	QT 1000	25	25	50	7,5	114	38	10	94	47	82	10	60	16
QT15-8D / QT15N-8D QT18N-8D / QTN20-8D QT20HP-8D / Dual Turn 20 SQT200-12D / SQT250-12D	QT 1500	25	50	75	7,5	114	38	10	94	47	100	10	60	20
QT15-12D / QT15N-12D / QT18N-12D / QT20N-12D / QT20HP-12D	QT 1540	25	25	53	7,5	114	38	10	94	47	100	10	60	20
QT20N-8D / QT25-8D	QT 2000	25	35	72,5	7,5	132	48	14	104	52	103	14	72	20

Stangengreifer

Bar pickup

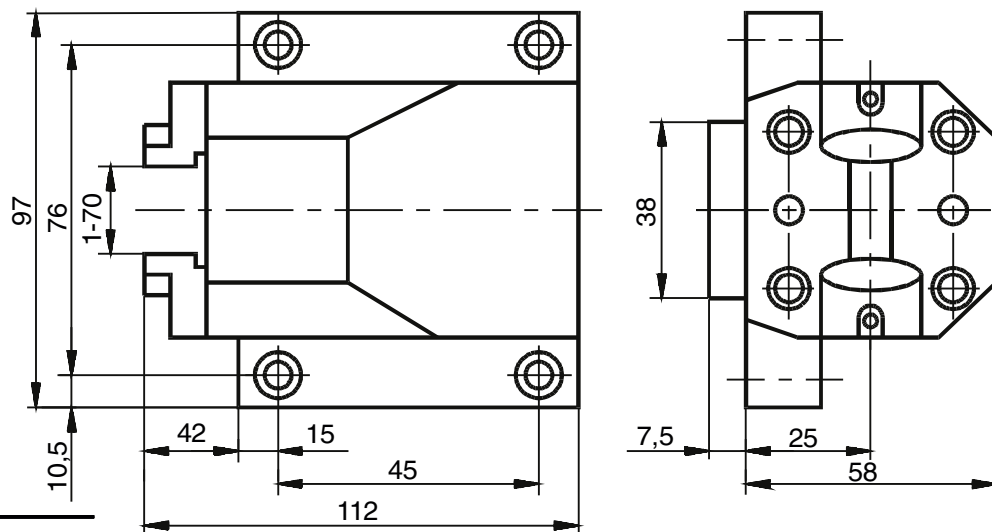

Maschinentyp	Nr. / No.
QTN10 / QT 8 QT 8N	QTG 8

Plandrehhalter

Facing turnholder

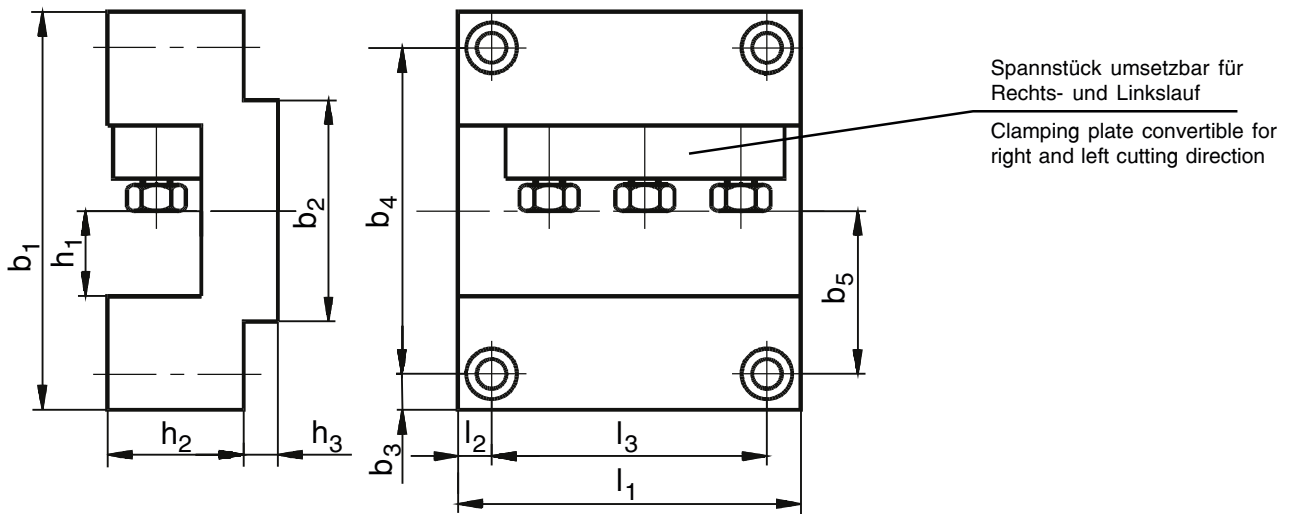

Maschinentyp	Nr. / No.	h_1	h_2	h_3	b_1	b_2	b_3	b_4	b_5	l_1	l_2	l_3
QT8-8D / QT8N-8D QTN10-8D	QT 829	20	30	7	95	38	9,5	76	36	70	15	45
QT10-8D	QT 1023	20	40	7,5	115	38	10	94	47	78	10	60
QT15-8D / QT15N-8D QT18N-8D / QTN20-8D QT20HP-8D / Dual Turn 20 SQT200-12D / SQT250-12D	QT 1523	25	43	8	114	38	10	94	47	98	10	60
QT15-12D / QT15N-12D QT18N-12D / QT20N-12D QT20HP-12D	QT 1549	25	38	7,5	110	38	11	88	44	96	26	55
QT20N-8D / QT25-8D	QT 2023	25	44	8	134	48	15	104	52	100	14	72
QT285-12D / QT28N-12D QT30N-12D / QTN30-12D	QT 2824	25	45	7	134	48	15	104	52	111	34	57

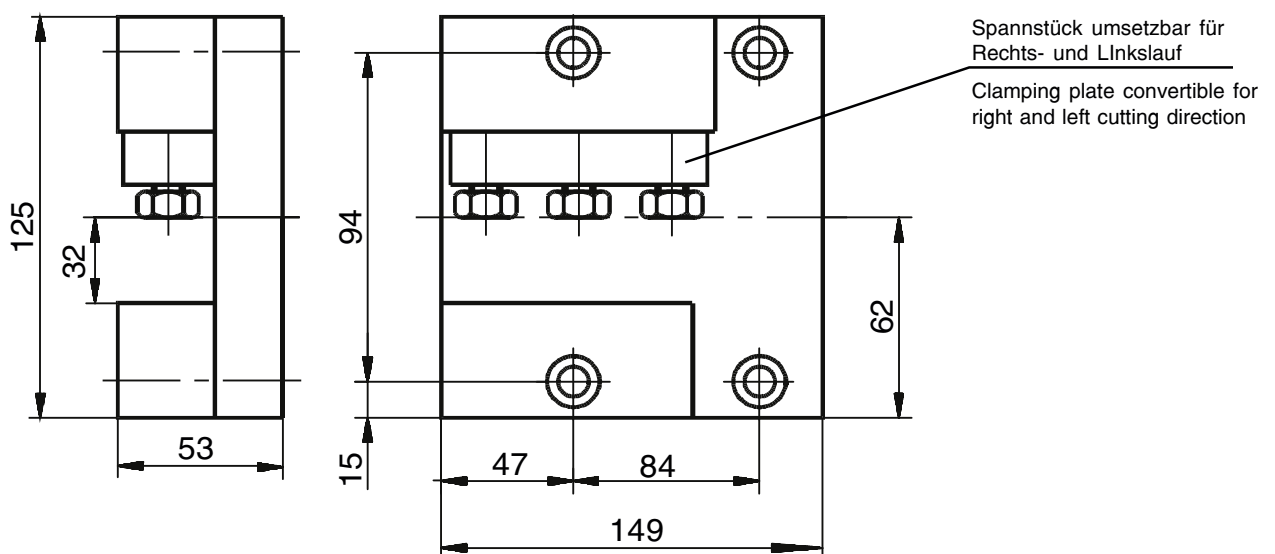

Maschinentyp	Nr. No.
QT35-12D QT35N-12D QTN40-12D	QT 3517

Außendrehhalter

Outside turnholder

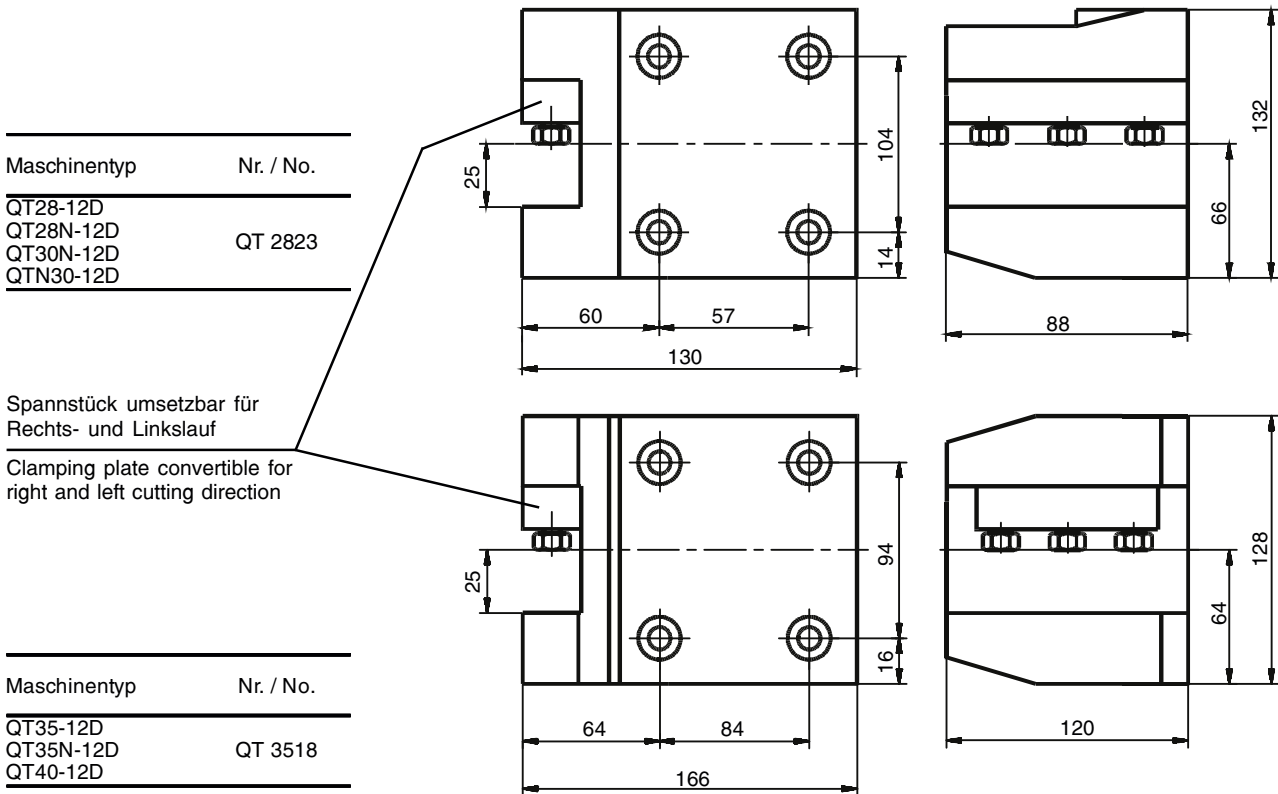

Stangengreifer

Bar pickup

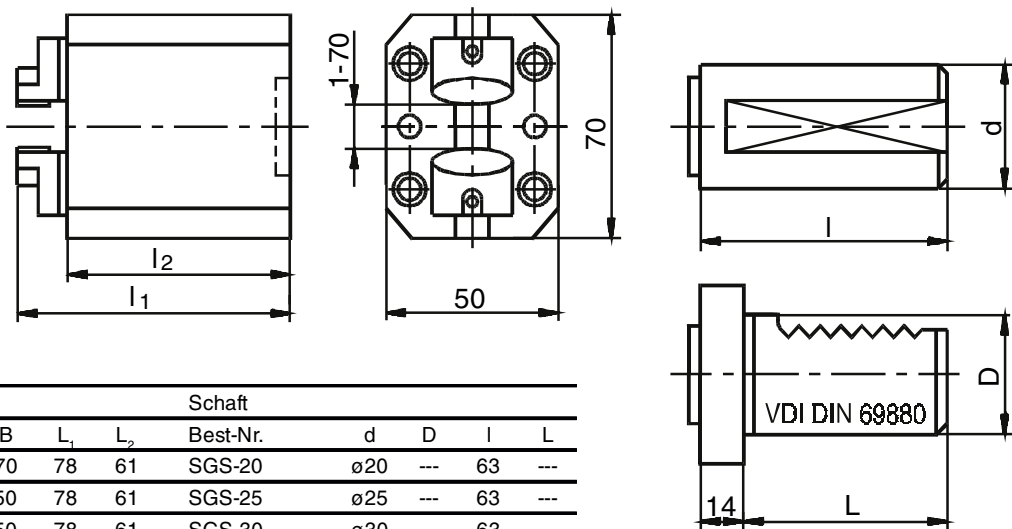

Stangenregister				Schaft					
Best-Nr.	A	B	L ₁	L ₂	Best-Nr.	d	D	l	L
SG-10	70	70	78	61	SGS-20	ø20	---	63	---
SG-10	70	50	78	61	SGS-25	ø25	---	63	---
SG-10	70	50	78	61	SGS-30	ø30	---	63	---
SG-10	70	50	78	61	SGS-32	ø32	---	63	---
SG-10	70	50	78	61	SGS-40	ø40	---	63	---
SG-10	70	50	78	61	SGS-50	ø50	---	63	---

Reduzierhülsen

Reducing sleeve

Douille de réduction

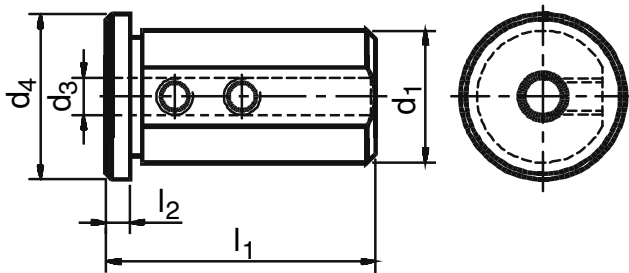

Best-Nr.	d ₁	d ₂	d ₃	d ₄	l ₁	l ₂
28.2506 S	25		6	29	50	4
28.2508 S	25		8	29	50	4
28.2510 S	25		10	29	50	4
28.2512 S	25		12	29	50	4
28.2516 S	25	16		29	50	4
28.2520 S	25	20		29	50	4
28.3206 G200	32		6	36	58	5
28.3208 G200	32		8	36	58	5
28.3210 G200	32		10	36	58	5
28.3212 G200	32		12	36	58	5
28.3216 G200	32	16		36	58	5
28.3220 G200	32	20		36	58	5
28.3225 G200	32	25		36	58	5

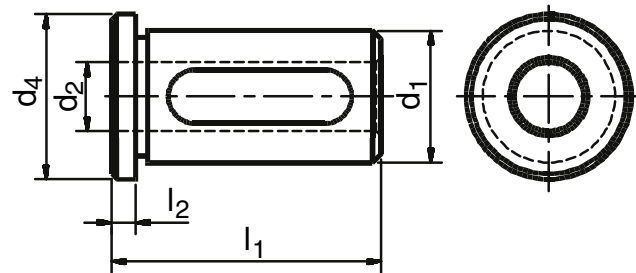

Best-Nr.	d ₁	d ₂	d ₃	d ₄	l ₁	l ₂
28.4008 S	40		8	44	58	5
28.4010 S	40		10	44	58	5
28.4012 S	40		12	44	58	5
28.4016 S	40	16		44	58	5
28.4020 S	40	20		44	58	5
28.4025 S	40	25		44	58	5
28.4032 S	40	32		44	58	5
28.5012 S	50		12	54	75	5
28.5016 S	50	16		54	75	5
28.5020 S	50	20		54	75	5
28.5025 S	50	25		54	75	5
28.5032 S	50	32		54	75	5
28.5040 S	50	40		54	75	5

Spannzangenfutter

mit Zylinderschaft
für Spannzangen 420 E

Collet chuck

for collet 430 E

Pendelhalter

mit Zylinderschaft

Floating toolholder for RD/ER collets

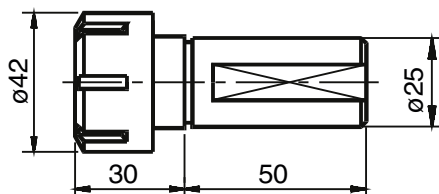

Best. Nr. 025 2550

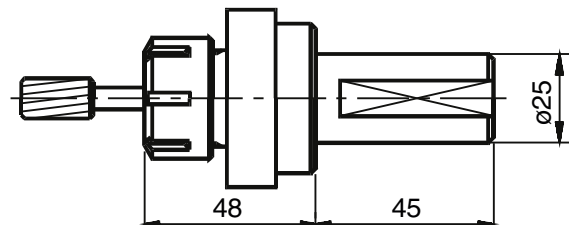

Best. Nr. 025 0025

Gewindeschneidfutter mit Längenausgleich auf Druck und Zug

mit Zylinderschaft

Tapping head with tension and compression

Bohrer-Einsatzhülsen Drill Insert Sleeve

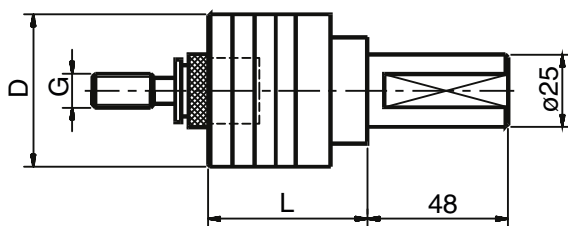

Best. Nr.	Größe	L	D	G
WFLK 1/25	1	41	36	M3-M12
WFLK 2/25	2	64	53	M8-M20

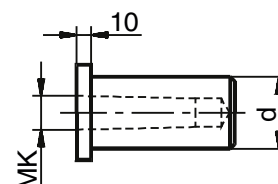

Best. Nr.	d	MK	Best. Nr.	d	MK
QT 831	25	1	QT 1532	40	2
QT 832	25	2	QT 1533	40	3
SQT 3201	32	1	QT 1534	40	4
SQT 3202	32	2	QT 2032	50	2
SQT 3203	32	3	QT 2033	50	3
QT 1531	40	1	QT 2034	50	4

Spannzangen

DIN 6499

Collets

DIN 6499

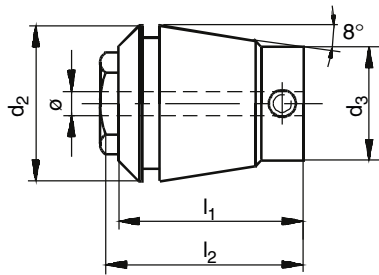
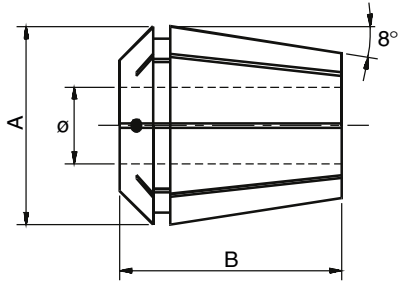
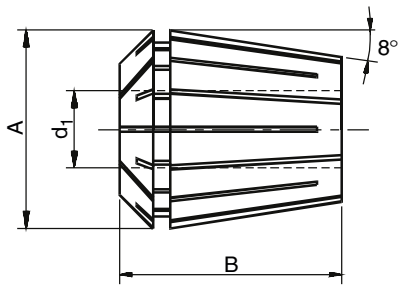

Mit Innenvierkant zum Gewindeschneiden / With square for tapping

Nr. / No.	d ₁	Stg.	A	B
110 4008E	1-7	0,5	11,5	18
160 426E	1-10	1	17	27
200 428E	2-13	1	21	31
250 430E	2-16	1	26	35
320 470E	3-20	1	33	40
400 472E	4-26	1	41	46

Nr. / No.	ømin.	ømax.
163T 426E-G	3,5	7
203T 428E-G	3,5	10
253T 430E-G	3,5	12
323T 470E-G	4,5	16
403T 472E-G	6	20

Hochpräzisions-Ausführung abgedichtet für Werkzeuge mit Innenkühlung / High precision execution for tools with inner cooling system

Nr. / No.	d ₁	Stg.	A	B
111 4008E NC	3-7	0,5	11,5	18
162 426E NC	3-10	0,5	17	27
202 428E NC	3-13	0,5	21	31
252 430E NC	3-16	0,5	26	35
322 470E NC	3-20	0,5	33	40
402 472E NC	4-26	0,5	41	46

Mit Innenvierkant zum Gewindeschneiden / With square for tapping

Nr. / No.	ømin.	ømax.
163T NC 426E-G	3,5	7
203T NC 428E-G	3,5	10
253T NC 430E-G	3,5	12
323T NC 470E-G	4,5	16
403T NC 472E-G	6	20

Mit Längenausgleich auf Zug - with tension zum Gewindeschneiden - for tapping

Nr. / No.	ømin.	ømax.	d ₂	d ₃	l ₁	l ₂	Z
164 426E-G	1,4	5,5	17	11	27	27	7
204 428E-G	2,2	7	21	14	31	31	7
254 430E-G	2,8	9	26	19	32	34	8
324 470E-G	4,5	12,5	33	23	41	43	10
404 472E-G	6	17	41	28	53	54	13

Spannzangen mit Längenausgleich auf Zug

zum Gewindeschneiden mit Schnellwechsel-System

Collets with tension

for tapping quick-change-system

Nr. / No.	ø	□	DIN				
RDTB 16 - 2,5	RDTB 20 - 2,5	RDTB 25 - 2,5	2,5	2,1	DIN		
RDTB 16 - 2,8	RDTB 20 - 2,8	RDTB 25 - 2,8	2,8	2,1	DIN		
RDTB 16 - 3,5	RDTB 20 - 3,5	RDTB 25 - 3,5	RDTB 32 - 2,5	RDTB 40 - 3,5	3,5	2,7	DIN
RDTB 16 - 4,0	RDTB 20 - 4,0	RDTB 25 - 4,0	RDTB 32 - 4,0	RDTB 40 - 4,0	4,0	3,0	DIN
RDTB 16 - 4,5	RDTB 20 - 4,5	RDTB 25 - 4,5	RDTB 32 - 4,5	RDTB 40 - 4,5	4,5	3,4	DIN
	RDTB 20 - 4,5I	RDTB 25 - 4,5I	RDTB 32 - 4,5I	RDTB 40 - 4,5I	4,5	3,55	ISO
	RDTB 20 - 6,0	RDTB 25 - 6,0	RDTB 32 - 6,0	RDTB 40 - 6,0	6,0	4,9	DIN
		RDTB 25 - 6,3I	RDTB 32 - 6,3I	RDTB 40 - 6,3I	6,3	5,0	ISO
		RDTB 25 - 7,0	RDTB 32 - 7,0	RDTB 40 - 7,0	7,0	5,5	DIN
		RDTB 25 - 8,0	RDTB 32 - 8,0	RDTB 40 - 8,0	8,0	6,2	DIN
		RDTB 25 - 8,0I	RDTB 32 - 8,0I	RDTB 40 - 8,0I	8,0	6,3	ISO
		RDTB 25 - 9,0	RDTB 32 - 9,0	RDTB 40 - 9,0	9,0	7,0	DIN
		RDTB 25 - 9,0I	RDTB 32 - 9,0I	RDTB 40 - 9,0I	9,0	7,1	ISO
			RDTB 32 - 10,0	RDTB 40 - 10,0	10,0	8,0	DIN
			RDTB 32 - 11,0	RDTB 40 - 11,0	11,0	9,0	DIN
			RDTB 32 - 11,2I	RDTB 40 - 11,2I	11,2	9,0	ISO
				RDTB 40 - 12,0	12,0	9,0	DIN
				RDTB 40 - 12,5I	12,5	10,0	ISO
				RDTB 40 - 14,0	14,0	11,0	DIN
				RDTB 40 - 14,0I	14,0	11,2	ISO

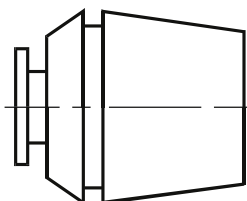

Schnellwechsel-Einsätze IG

ohne Sicherheitskupplung zur Aufnahme von Gewindebohrer

Quick change inserts IG

for taper

Porte-taraud à changement rapide

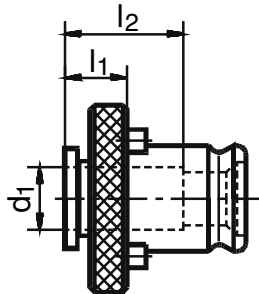

Nr. / No.	Gr.	d ₁	□	l ₁	l ₂
IG 1-2521	1	2,5	2,1	7	17
IG 1-2821	1	2,8	2,1	7	17
IG 1-3125	1	3,15	2,5	7	17
IG-1-3527	1	3,5	2,7	7	17
IG 1-3528	1	3,55	2,8	7	17
IG 1-4030	1	4	3	7	17
IG 1-4031	1	4	3,1	7	17
IG 1-4534	1	4,5	3,4	7	17
IG 1-5040	1	5	4	7	17
IG 1-6049	1	6	4,9	7	17
IG 1-6350	1	6,3	5	7	17
IG 1-7055	1	7	5,5	7	17
IG 1-8062	1	8	6,2	7	17
IG 1-9070	1	9	7	7	17
IG 1-10080	1	10	8	7	17
IG 1-11090	1	11	9	7	17
IG 1-11290	1	11,2	9	7	17

Schnellwechsel-Einsätze AG

zur Aufnahme von Schneideisen

Quick change inserts AG

for taper

Porte-filière à changement rapide

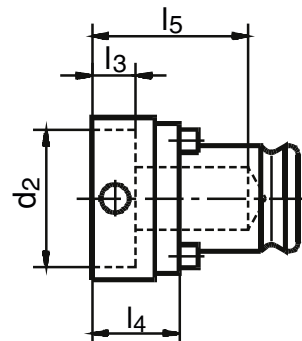

Nr. / No.	Gr.	d ₁	□	l ₁	l ₂
IG 2-6049	2	6	4,9	11	30
IG 2-6350	2	6,3	5	11	30
IG 2-7055	2	7	5,5	11	30
IG 2-8062	2	8	6,2	11	30
IG 2-9070	2	9	7	11	30
IG 2-10080	2	10	8	11	30
IG 2-11090	2	11	9	11	30
IG 2-11290	2	11,2	9	11	30
IG 2-12090	2	12	9	11	30
IG 2-125100	2	12,5	10	11	30
IG 2-140110	2	14	11	11	30
IG 2-140112	2	14	11,2	11	30
IG 2-160120	2	16	12	11	30
IG 2-160125	2	16	12,5	11	30
IG 2-180140	2	18	14	11	30
IG 2-180145	2	18	14,5	11	30

Nr. / No.	Gr.	d ₁	□	l ₁	l ₂
AG 1-1605	1	16	4,8	14	28
AG 1-2005	1	20	4,8	14	28
AG 1-2007	1	20	6,5	16	30
AG 1-2509	1	25	8,5	19	33
AG 1-3011	1	30	10	21	35
AG 1-3810	1	38	9	20	34
AG 1-3814	1	38	13	24	38
AG 2-2005	2	20	4,8	20	55
AG 2-2007	2	20	6,5	21,5	56
AG 2-2509	2	25	8,5	23,5	55
AG 2-3011	2	30	10	22	57
AG 2-3810	2	38	9	21	56
AG 2-3814	2	38	13	25	60
AG 2-4514	2	45	13	25	60
AG 2-4518	2	45	17	35	64

Spannzangeneinsatz

für Kombihalter

Collert insert

for combi holder

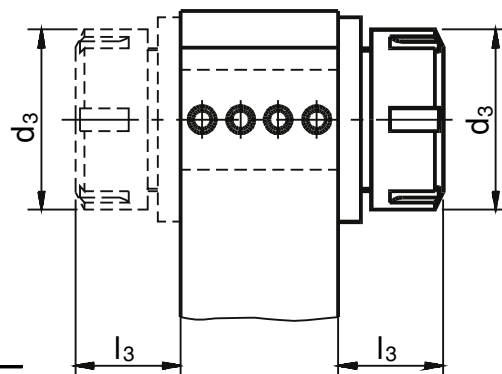
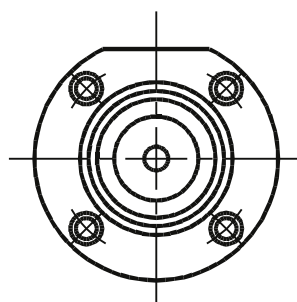
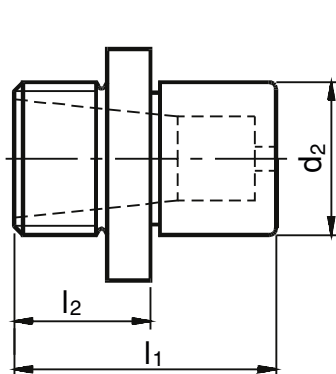

Maschinentyp	Nr. / No.	d ₂	d ₃	l ₁	l ₂	l ₃	Spannzangentyp Collert type
SQT 10	ZE 3225 M	32	42	49	25	37	250 430 E ø2-16
SQT 10	ZE 3232 M	32	50	52	28	41	320 470 E ø3-20
SQT 15/18	ZE 3225 M	32	42	49	25	37	250 430 E ø2-16
SQT 15/18	ZE 4025 M	40	42	49	25	37	250 430 E ø2-16
SQT 15/18	ZE 4032 M	40	50	52	28	41	320 470 E ø3-20
SQT 28/30	ZE 5040 M	50	63	52	28	42	400 472 E ø4-26

Kombihalter

Combiholder

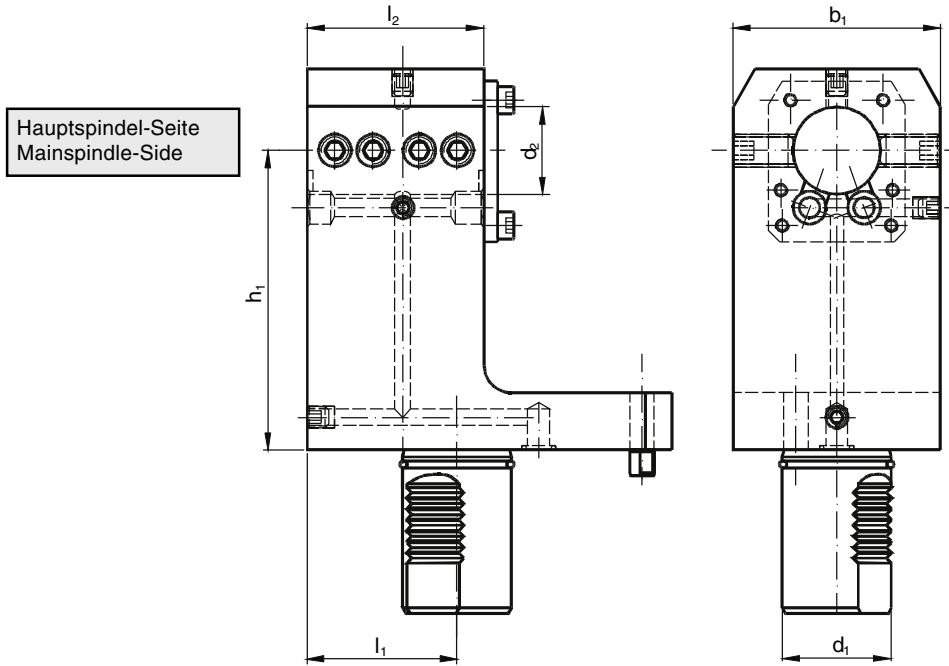

Maschinentyp	Nr. / No.	d ₁	d ₂	h ₁	l ₁	l ₂	b ₁
SQT 10M-12D / SQT 15M-16D	17.4025 SQT10	40	25	110	55	65	76
SQT 15MS-16D / SQT 200M-16D	17.4032 SQT10	40	32	110	55	65	76
SQT 15M-12D	17.4025 SQT15	40	25	140	55	70	80
SQT 18M-12D	17.4032 SQT15	40	32	140	55	70	80
SQT 200M-12D	17.4040 SQT15	40	40	140	55	70	80
SQT 28M12D	SQT2832 1751	50	32	175	63	90	92
SQT 30M-12D	SQT2850 1751	50	50	175	63	90	92

Mit ABS-/UTS-/Capto-/Zoll-ø/Sonder-ø auf Anfrage (on request)

Reduzierhülsen, siehe Seite 6.5
 Reducing sleeve, see page 6.5
 Douille de réduction, voir page 6.5

Für Innen- und Außenkühlung
 For internal and external cooling

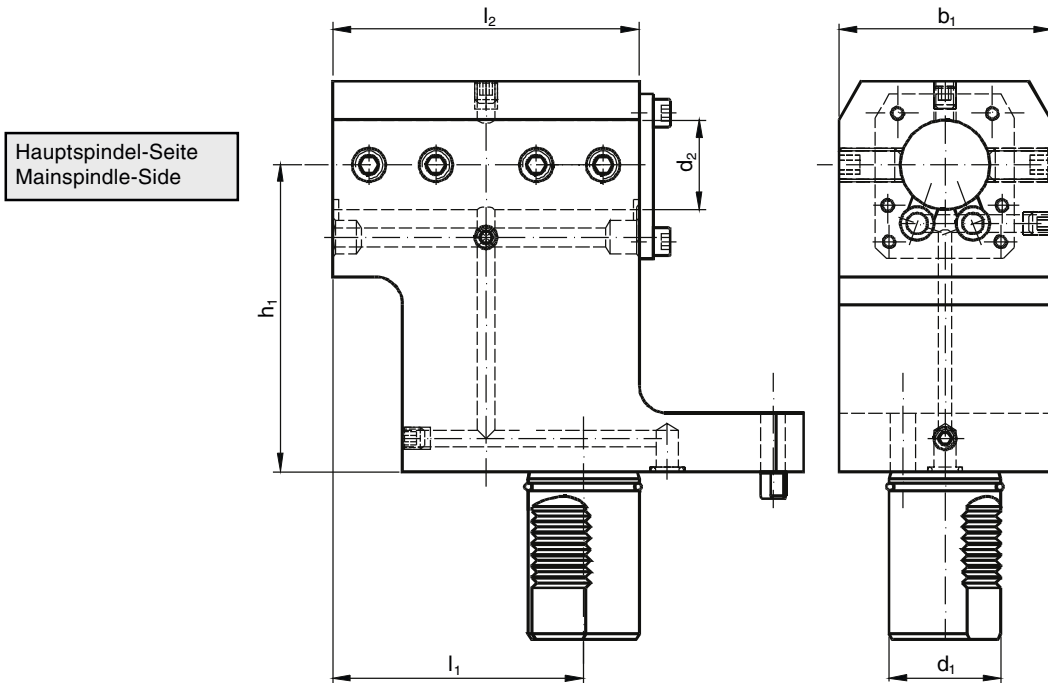

Maschinentyp	Nr. / No.	d ₁	d ₂	h ₁	l ₁	l ₂	b ₁
SQT 250M-16D	17.4032 DSQT10	40	32	110	90	110	76
SQT 250M-12D	17.4040 DSQT15	40	40	140	90	110	84

Mit ABS-/UTS-/Capto-/Zoll-ø/Sonder-ø auf Anfrage (on request)

Reduzierhülsen, siehe Seite 6.5
 Reducing sleeve, see page 6.5
 Douille de réduction, voir page 6.5

Für Innen- und Außenkühlung
 For internal and external cooling

Kombi-Außendrehhalter R/L

Combi-outside holder R/L

SQT 2825 1503R wie gezeichnet
as drawn
SQT 2825 1504 L spiegelbildlich
mirror-inverted

Maschinentyp	Nr. / No.	d_1	h_1	h_2	l_1	b_1
SQT 10M-12D						
SQT 15M-16D						
SQT 15MS-16D	1.4020 SQT10	40	20	76	100	---
SQT 200M-16D						
SQT 150M-16D						
SQT 15M-12D						
SQT 18M-12D						
SQT 200M-12D	1.4025 SQT15	40	25	86	120	78
SQT 250M-12D						
SQT 28M-12D	SQT 2825 1507R	50	25	100	150	86
SQT 30M-12D	SQT 2825 1507L	50	25	100	150	86
SQT 300M-12D						

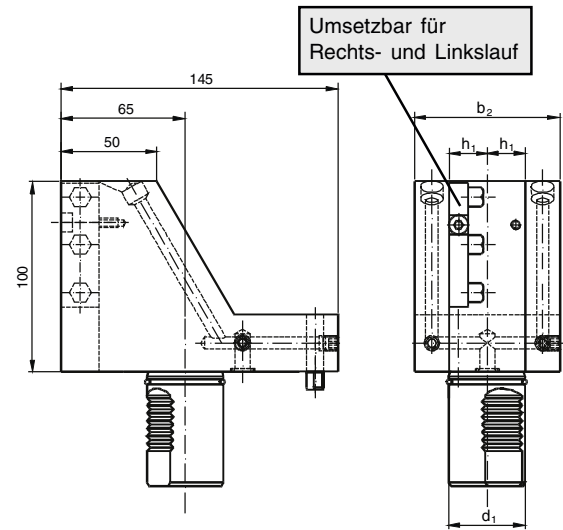

Kombi-Duo- Außendrehhalter R/L

Combi-duo- outside holder R/L

Maschinentyp	Nr. / No.	d_1	h_1	l_1	l_2	l_3
SQT 10MS-12D						
SQT 15MS-16D						
SQT 200MS-16D	SQT 1020 1259	40	20	45	100	73
SQT 250MS-16D						
SQT 15MS-12D						
SQT 18MS-12D						
SQT 200MS-12D	SQT 1825 1259	40	25	40	125	70
SQT 250MS-12D						
SQT 28MS-12D						
SQT 30MS-12D	SQT 2825 1509	50	25	46	146	75
SQT 300M-12D						

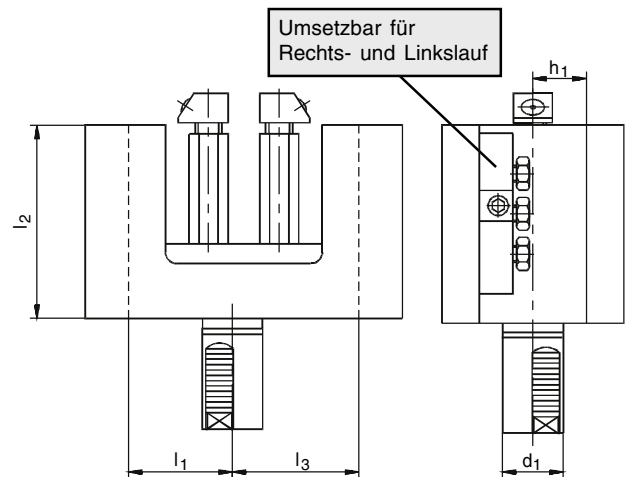

Kombi-Plandrehhalter R/L

Combi-facing holder R/L

Maschinentyp	Nr. / No.	d_1	h_1	h_2	l_1	b_1	b_2
SQT 10M-12D							
SQT 15M-16D							
SQT 15MS-16D	SQT 1020 1106	40	20	76	110	60	110
SQT 200M-16D							
SQT 250M-16D							
SQT 15M-12D							
SQT 18M-12D							
SQT 200M-12D	SQT 1825 1406	40	25	86	143	65	115
SQT 250M-12D							
SQT 28M-12D							
SQT 30M-12D	SQT 2825 1706	50	25	98	163	57	120
SQT 300M-12D							

Hauptspindel-Seite
Mainspindle-side

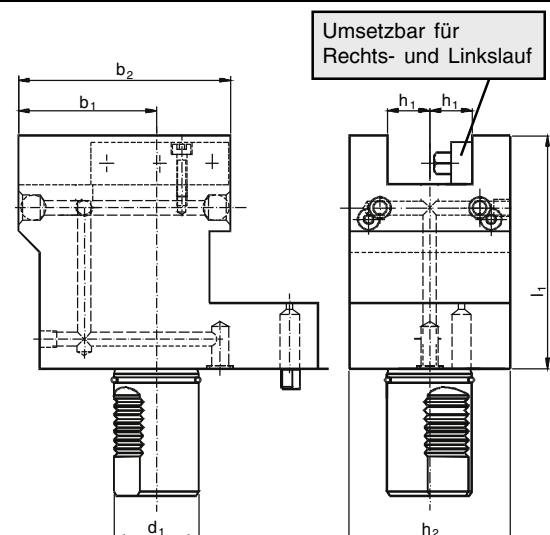

Mehrfachdrehhalter

Multiple tool holder

Hauptspindel-Seite
Mainspindle-side

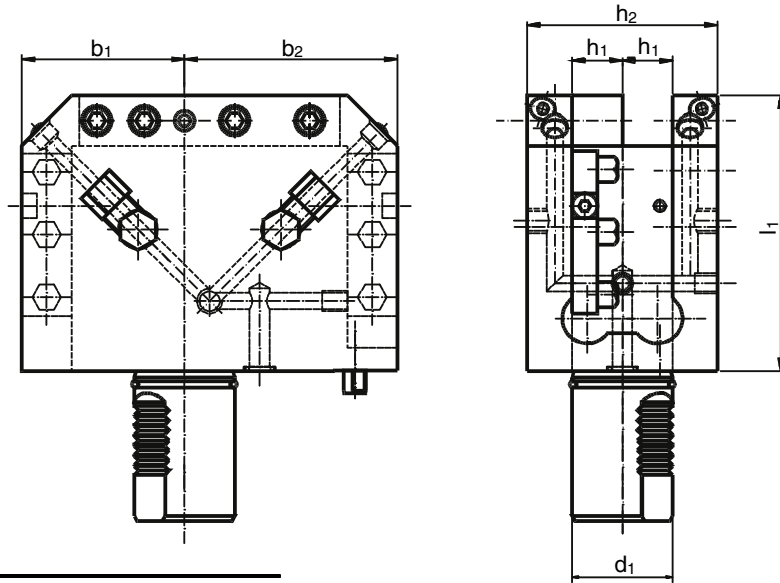

Maschinentyp	Nr. / No.	d_1	h_1	h_2	l_1	b_1	b_2
SQT 10MS-12D	15.4020 SQT10	40	20	76	110	65	85
SQT 15MS-16D							
SQT 200MS-16D							
SQT 250MS-16D							
SQT 15MS-12D	15.4025 SQT15	40	25	100	136	78	88
SQT 18MS-12D							
SQT 200MS-12D							
SQT 250MS-12D							

Kombihalter

Combi holder

Reduzierhülsen, siehe Seite 6.5
Reducing sleeve, see page 6.5

Spannzangeneinsätze, Seite 6.7
Collert inserts, page 6.7

Mit ABS-/UTS-/Capto-/Zoll- \emptyset /Sonder- \emptyset
auf Anfrage (on request)

Für Innen- und Außenkühlung
For internal and external cooling

Hauptspindel-Seite
Mainspindle-side

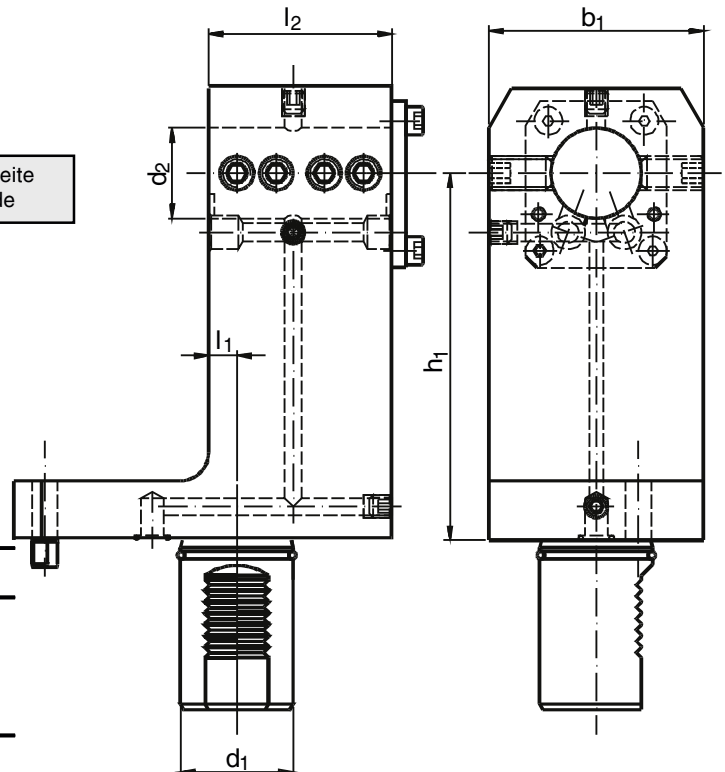

Maschinentyp	Nr. / No.	d_1	d_2	h_1	l_1	l_2	b_1
MP 410N-12D	17.4025 MP 610	40	25	130	10	65	76
MP 415N-12D							
MP 610-12D							
MP 610N-12D							
MP 615N-12D	17.4032 MP 620	40	32	130	10	65	76
MP 6200-16D							
MP 420N-12D							
MP 620-12D							
MP 620N-12D	17.4032 MP 620	40	32	150	10	70	76
MP 620-12D							
MP 620N-12D							
MP 6200-12D	17.4040 MP 620	40	40	150	10	70	76

Halter für MAZAK MP 630 / MP 6300 auf Anfrage.
Tools for MAZAK MP 630 / MP 6300 on request.

Kombi-Außendrehhalter

Combi-outside holder

Halter für MAZAK MP 630 / MP 6300 auf Anfrage.
Tools for MAZAK MP 630 / MP 6300 on request.

Hauptspindel-Seite
Mainspindle-side

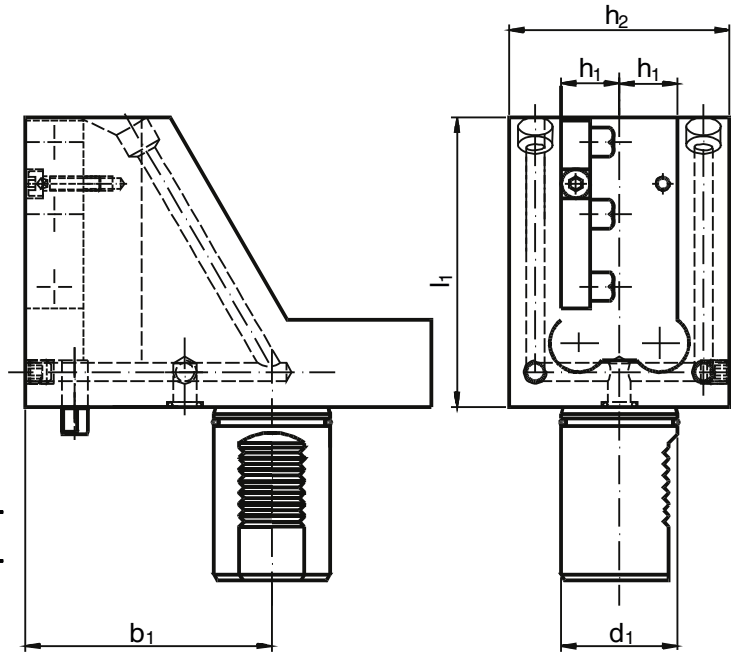

Maschinentyp	Nr. / No.	d_1	h_1	h_2	l_1	b_1
MP 410N-12D						
MP 415N-12D						
MP 610-12D	1.4020 MP610	40	20	76	100	85
MP 610N-12D						
MP 615N-12D						
MP 6200-16D						
MP 420N-12D						
MP 620-12D	1.4025 MP620	40	25	50	120	83
MP 620N-12D						
MP 6200-12D						

Kombi-Plandrehhalter

Combi-facing holder

Halter für MAZAK MP 630 / MP 6300 auf Anfrage.
Tools for MAZAK MP 630 / MP 6300 on request.

Hauptspindel-Seite
Mainspindle-side

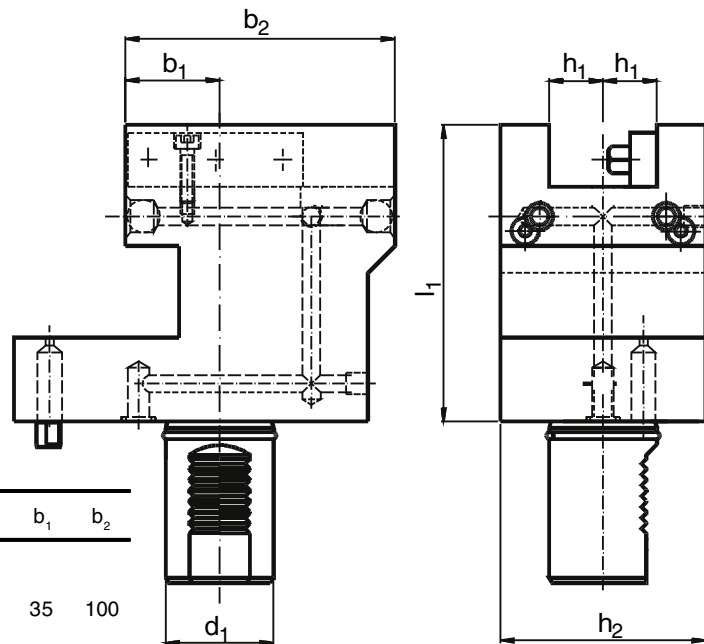

Maschinentyp	Nr. / No.	d_1	h_1	h_2	l_1	b_1	b_2
MP 410N-12D							
MP 415N-12D							
MP 610-12D	MP 6120 1016	40	20	76	110	35	100
MP 610N-12D							
MP 615N-12D							
MP 6200-16D							
MP 420N-12D							
MP 620-12D	MP 6225 1406	40	25	80	143	55	115
MP 620N-12D							
MP 6200-12D							

Abstechhalter für Stahlhöhe SH 32

Infeed Toolholder
SH 32

für SQT-Reihe

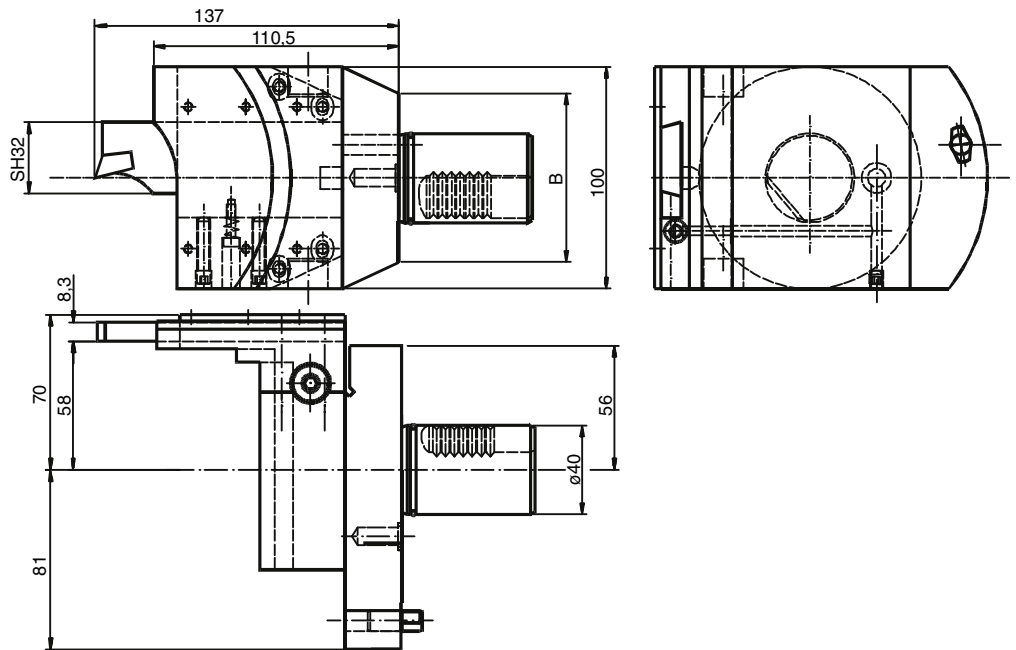

Maschinentyp	Nr. / No.	SH	B	
SQT 10M-12D / SQT 15M-16D	32.4032 SQT10 ÜK	32	76	wie gezeichnet
SQT 15M-16D / SQT 200M-16D	32.4032 SQT10	32	76	Schneide spiegelbildlich
SQT 250M-16D				
SQT 15M-12D / SQT 18M-12D	32.4032 SQT15 ÜK	32	84	wie gezeichnet
SQT 200M-12D / SQT 250M-12D	32.4032 SQT15	32	84	Schneide spiegelbildlich
SQT 10M-12D / SQT 15M-16D	32.4032 SQT10 LÜK	32	76	
SQT 15M-16D / SQT 200M-16D	32.4032 SQT10 L	32	76	Auch in L-Version verfügbar (Schneide in Richtung zur 2. Spindel)
SQT 250M-16D				
SQT 15M-12D / SQT 18M-12D	32.4032 SQT15 LÜK	32	84	Also in L-Version available
SQT 200M-12D / SQT 250M-12D	32.4032 SQT15 L	32	84	(Cutting tool in direction to 2nd Spindle)

Abstechhalter für Stahlhöhe SH 32

Infeed Toolholder
SH 32

für MP-Reihe

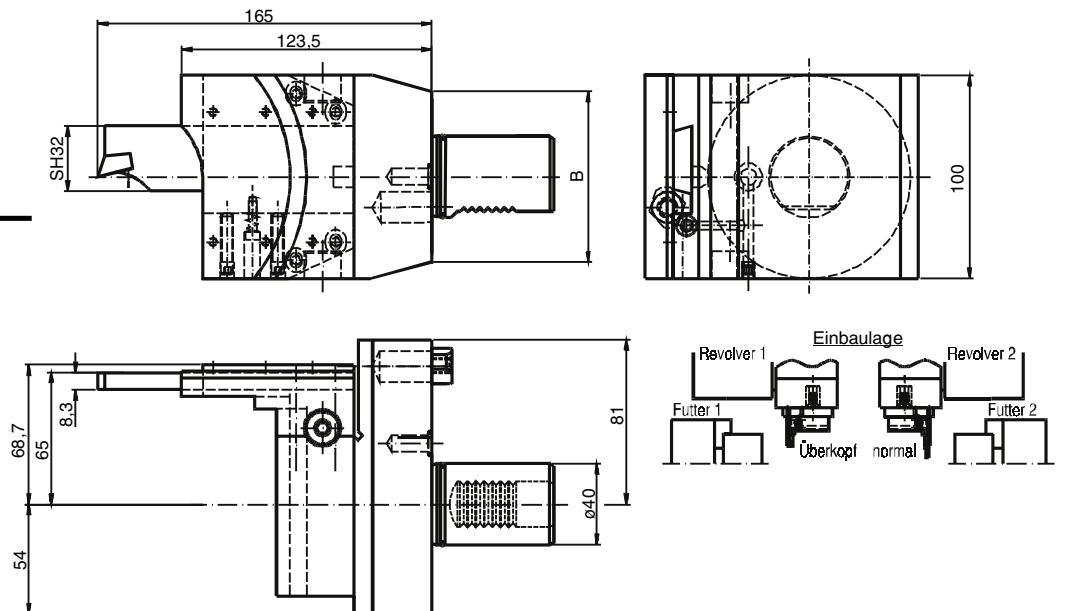

Maschinentyp	Nr. / No.	SH	B	
MP410N-12D / MP 415N-12D	32.4032 MP610 ÜK	32	76	wie gezeichnet
MP610-12D / MP6200-16D	32.4032 MP610	32	76	Schneide spiegelbildlich
MP420N-12D / MP620-12D	32.4032 MP620 ÜK	32	84	wie gezeichnet
MP620N-12D / MP6200-12D	32.4032 MP620	32	84	Schneide spiegelbildlich
MP410N-12D / MP415N-12D	32.4032 MP610 LÜK	32	76	
MP610-12D / MP6200-16D	32.4032 MP610 L	32	76	Auch in L-Version verfügbar (Schneide in Richtung zur 2. Spindel)
MP420N-12D / MP620-12D	32.4032 MP620 LÜK	32	84	Also in L-Version available
MP620N-12D / MP6200-12D	32.4032 MP620 L	32	84	(Cutting tool in direction to 2nd Spindle)

Reduzierhülsen mit Innenkühlung

Reducing sleeve with internal cooling supply

Douille de réduction avec lubrification interne

für Original
MAZAK-Werkzeughalter

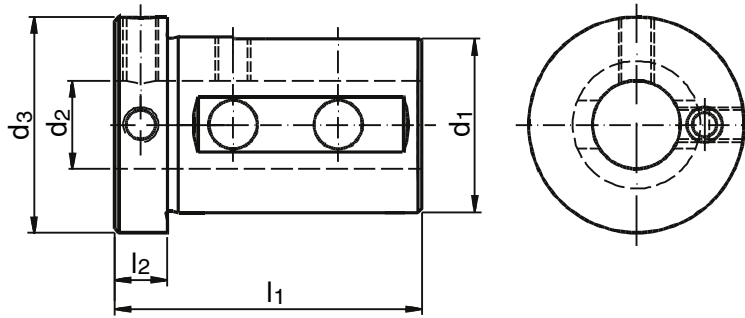

umsetzbar für interne /
externe Kühlmittelversorgung
convertible for internal /
external coolant supply

Nr. / No.	d ₁	d ₂	d ₃	l ₁	l ₂
QT 828	25	6	34	65	10
QT 827	25	8	34	65	10
QT 826	25	10	34	65	10
QT 825	25	12	34	65	10
QT 824	25	16	34	65	10
QT 823	25	20	34	65	10
QT 808	30	6	44	72	10
QT 807	30	8	44	72	10
QT 806	30	10	44	72	10
QT 805	30	12	44	72	10
QT 804	30	16	44	72	10
QT 803	30	20	44	72	10
QT 802	30	25	44	72	10
QT 1509	40	6	49	78	10
QT 1508	40	8	49	78	10
QT 1507	40	10	49	78	10
QT 1506	40	12	49	78	10
QT 1505	40	16	49	78	10
QT 1504	40	20	49	78	10
QT 1503	40	25	49	78	10
QT 1502	40	32	49	78	10
QT 2009	50	8	63	97	12
QT 2008	50	10	63	97	12
QT 2007	50	12	63	97	12
QT 2006	50	16	63	97	12
QT 2005	50	20	63	97	12
QT 2004	50	25	63	97	12
QT 2003	50	32	63	97	12
QT 2002	50	40	63	97	12

Nr. / No.	d ₁	d ₂	d ₃	l ₁	l ₂
SQT 10 2006	20	6	34	45	10
SQT 10 2008	20	8	34	45	10
SQT 10 2010	20	10	34	45	10
SQT 10 2012	20	12	34	45	10
SQT 10 2016	20	16	34	45	10
SQT 10 3206	32	6	48	63	12
SQT 10 3208	32	8	48	63	12
SQT 10 3210	32	10	48	63	12
SQT 10 3212	32	12	48	63	12
SQT 10 3216	32	16	48	63	12
SQT 10 3220	32	20	48	63	12
SQT 10 3225	32	25	48	63	12
SQT 18 4006	40	6	49	70	12
SQT 18 4008	40	8	49	70	12
SQT 18 4010	40	10	49	70	12
SQT 18 4012	40	12	49	70	12
SQT 18 4016	40	16	49	70	12
SQT 18 4020	40	20	49	70	12
SQT 18 4025	40	25	49	70	12
SQT 18 4032	40	32	49	70	12
SQT 20 4006	40	6	49	82	12
SQT 20 4008	40	8	49	82	12
SQT 20 4010	40	10	49	82	12
SQT 20 4012	40	12	49	82	12
SQT 20 4016	40	16	49	82	12
SQT 20 4020	40	20	49	82	12
SQT 20 4025	40	25	49	82	12
SQT 20 4032	40	32	49	82	12

Spannschraube Clamping screw

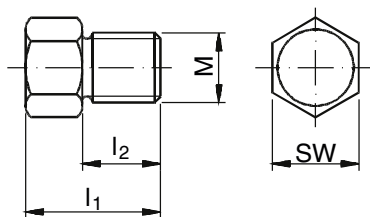

Nr. / No.	M	l ₁	l ₂	SW
G 111	M8	19	11	10
G 104	M12	23	14	14

Kühlelemente Coolant nozzle

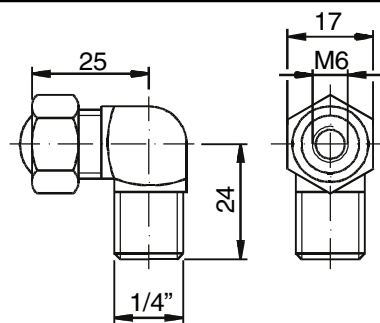

Nr. / No.	QT 301

Spannzangen- aufnahme

Collet chuck holder

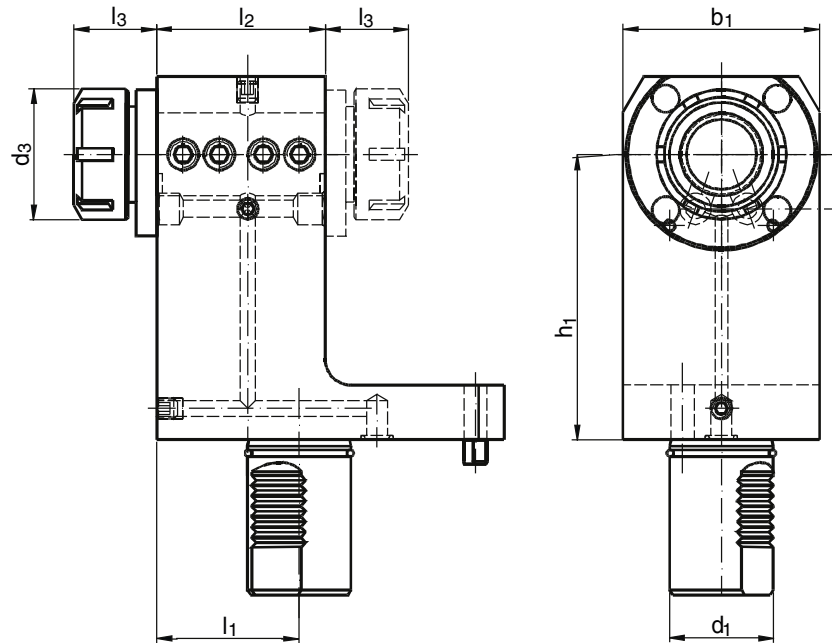

interne Kühlmittelversorgung
internal coolant supply

Maschinentyp	Nr. / No.	d ₁	d ₃	h ₁	l ₁	l ₂	l ₃	b ₁	Spannzangentyp Collet type
SQT 10M-12D / SQT 15M-16D	31.4025 SQT 10	40	42	110	55	65	37	76	250 430 E ø2-16
SQT 15MS-16D / SQT 200M-16D	31.4032 SQT 10	40	50	110	55	65	41	76	320 470 E ø3-20
SQT 250M-16D									
SQT 15M-12D	31.4025 SQT 15	40	42	140	55	70	37	80	250 430 E ø2-16
SQT 18M-12D									
SQT 200M-12D	31.4032 SQT 15	40	50	140	55	70	41	80	320 470 E ø3-20
SQT 250M-12D									

Spannzangen- aufnahme

Collet chuck holder double version

doppelseitige Ausführung

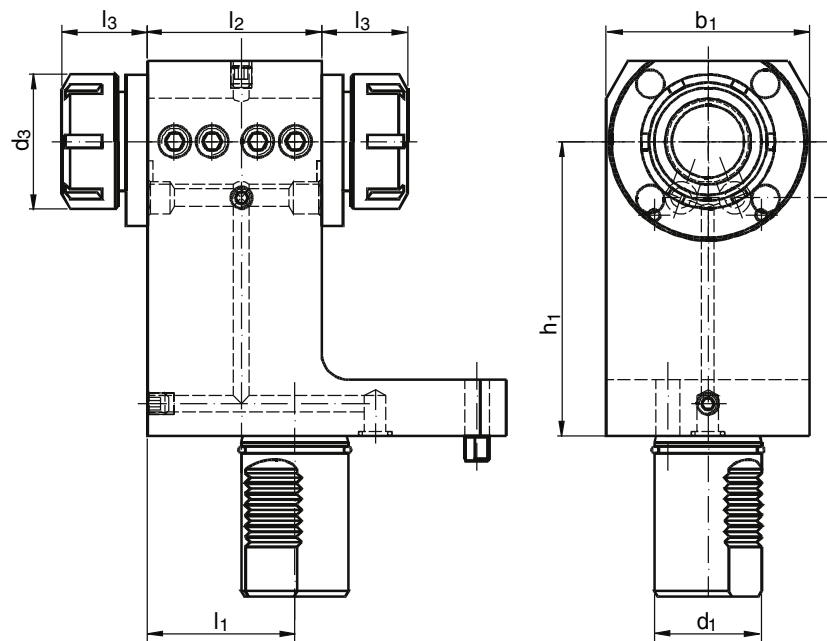

interne Kühlmittelversorgung
internal coolant supply

Maschinentyp	Nr. / No.	d ₁	d ₃	h ₁	l ₁	l ₂	l ₃	b ₁	Spannzangentyp Collet type
SQT 10MS-12D / SQT 100MS-12D	31.4025 DSQT 10	40	42	110	55	65	37	76	250 430 E ø2-16
SQT 15MS-16D / SQT 18MS-16D	31.4032 DSQT 10	40	50	110	55	65	41	76	320 470 E ø3-20
SQT 200MS-16D / SQT 250MS-16D									
SQT 15MS-12D / SQT 18MS-12D	31.4025 DSQT 15	40	42	140	55	70	37	80	250 430 E ø2-16
SQT 200MS-12D / SQT 250MS-12D	31.4032 DSQT 15	40	50	140	55	70	41	80	320 470 E ø3-20

Axial Bohr- und Fräskopf

Axial drilling and milling head

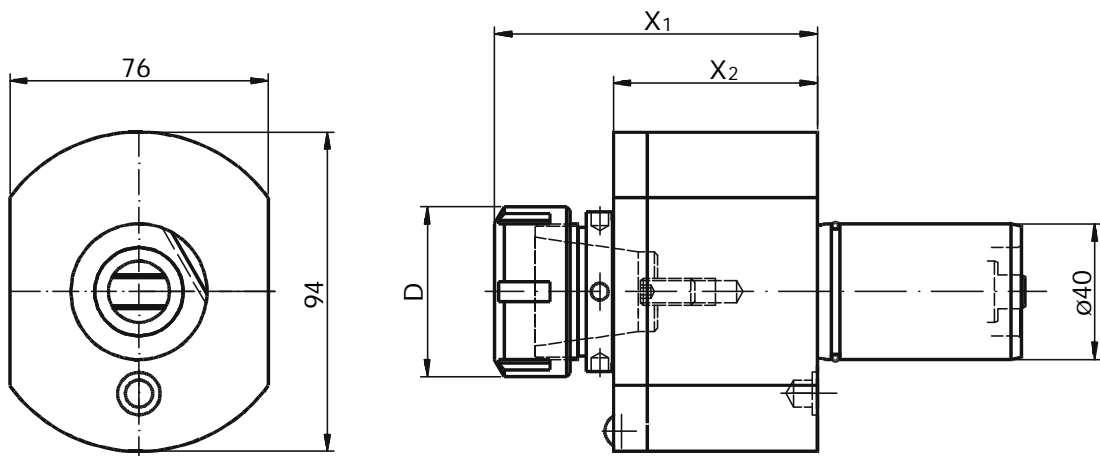

Innere Kühlmittelzufuhr: Zusatz IK an Bestellnummer anfügen
Internal cooling supply: Please add IK behind order no.

Auch als y-verstellbar verfügbar
Also then y-axis adjustable available

Maschinentyp	Nr. / No.	i	n_{max}	T_{max}	x_1	x_2	D	Spannzangentyp Collet type
SQT 10M-12D / SQT 15M-16D SQT 15M-16D / SQT 200M-16D SQT 250M-16D	40.4025 SQT 10	1:1	6000	50	92	60	42	RD/ER 25 430E (2-16)
SQT 15M-12D / SQT 18M-12D	40.4032 SQT 15	1:1	6000	50	95	60	50	RD/ER 32 470E (3-20)
	40.5040 SQT 28	1:1	4000	80	136	91	63	RD/ER 40 472E (4-26)

Axial Fräskopf modular

Axial milling head modular

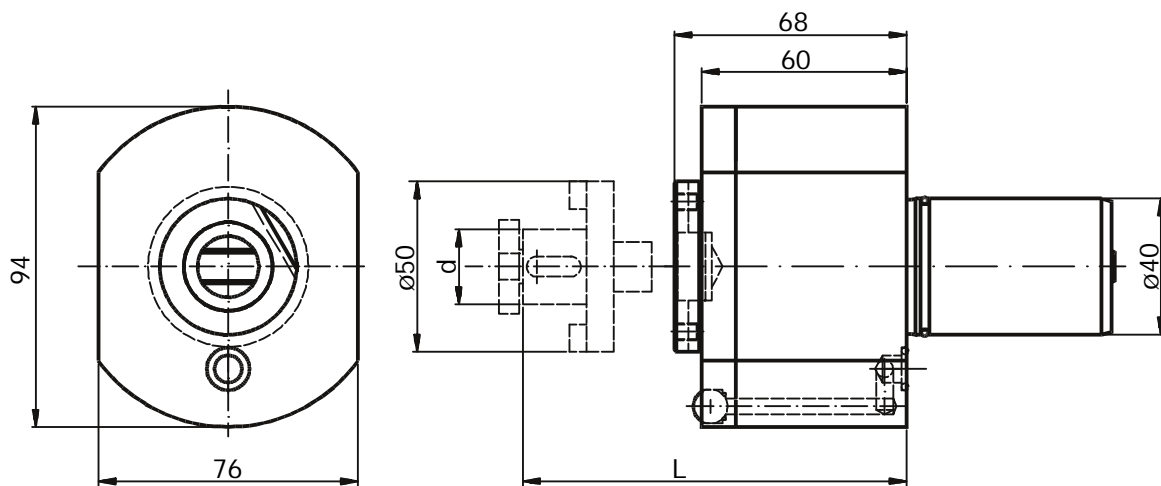

Maschinentyp	Nr. / No.	i	n_{max}	T_{max}	L	d
SQT 10M-12D / SQT 15M-16D SQT 15M-16D / SQT 200M-16D SQT 250M-16D	42.4000 SQT 10	1:1	6000	50	68 + x	siehe Tabelle
SQT 15M-12D / SQT 18M-12D SQT 200M-12D / SQT 250M-12D	42.4000 SQT 15	1:1	6000	50	68 + x	

Nr. / No.	d	x
501.507	13	24
501.510	16	29
501.520	22	31
501.530	27	33

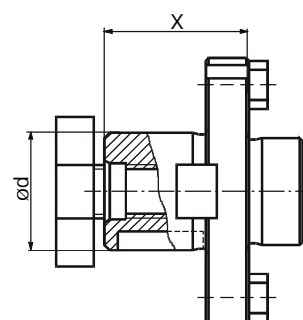

Axial Bohr- und Fräskopf

versetzt

Axial drilling and milling head

offset

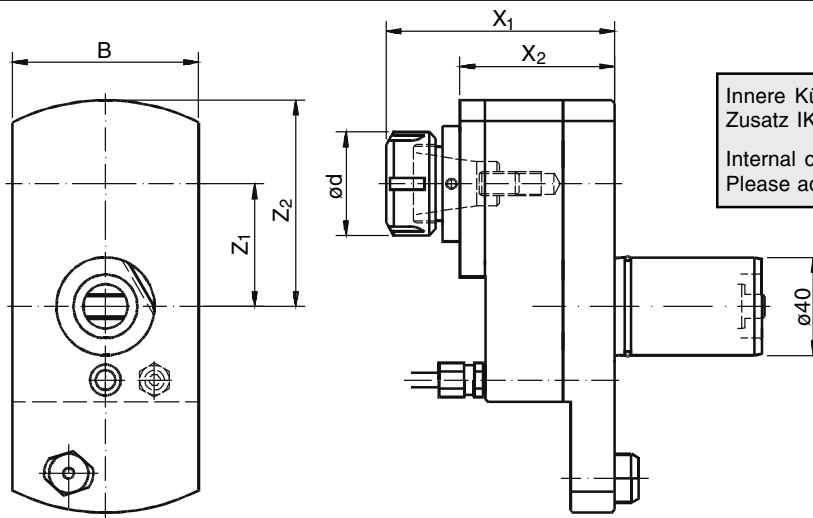

Innere Kühlmittelzufuhr:
Zusatz IK an Bestellnummer anfügen
Internal cooling supply:
Please add IK behind order no.

Maschinentyp	Nr. / No.	i	n _{max}	T _{max}	x ₁	x ₂	Z ₁	Z ₂	B	d	Spannzangentyp Collet type
SQT 10M-12D	50.4025 SQT 10	1:1	6000	50	93	63	50	84	76	42	RD/ER 25 430E (2-16)
SQT 15M-16D	50.4032 SQT 10	1:1	6000	50	95	63	50	84	76	50	RD/ER 32 470E (3-20)
SQT 15M-16D	50.4025 SQT 10 IK	1:1	6000	50	120	80	50	84	76	42	RD/ER 25 430E (2-16)
SQT 200M-16D	50.4032 SQT 10 IK	1:1	6000	50	122	80	50	84	76	50	RD/ER 32 470E (3-20)
SQT 250M-16D	50.4025 SQT 10 I1	1:2	12000	25	120	80	50	84	76	42	RD/ER 25 430E (2-16)
	50.4025 SQT 15	1:1	6000	50	93	63	50	84	76	42	RD/ER 25 430E (2-16)
	50.4032 SQT 15	1:1	6000	50	95	63	50	84	76	50	RD/ER 32 470E (3-20)
SQT 15M-12D	50.4025 SQT 15 IK	1:1	6000	50	120	80	50	84	76	42	RD/ER 25 430E (2-16)
SQT 18M-12D	50.4032 SQT 15 IK	1:1	6000	50	122	80	50	84	76	50	RD/ER 32 470E (3-20)
SQT 200M-12D	50.4025 SQT 15 I1	1:2	12000	25	120	80	50	84	76	42	RD/ER 25 430E (2-16)
SQT 250M-12D	50.4025 SQT 15 I 1751	1,75:1	6000	60	120	80	50	84	76	42	RD/ER 25 430E (2-16)
	50.4032 SQT 15 I 1751	1,75:1	3430	60	122	80	50	84	76	50	RD/ER 32 470E (3-20)
	50.5040 SQT 28	1:1	4000	80	119	79	62,5	105	95	63	RD/ER 40 472E (4-26)

Axial Gewinde-Bohrkopf

Axial tapping head

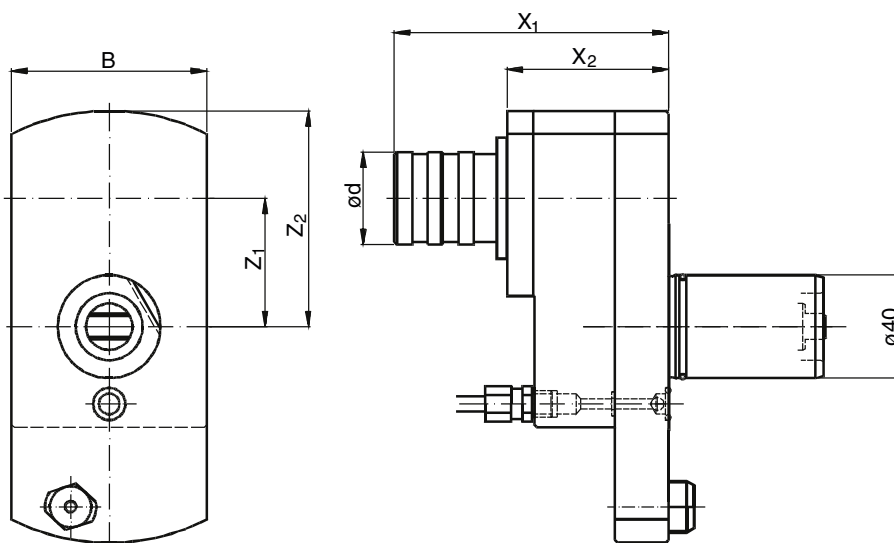

Maschinentyp	Nr. / No.	i	n _{max}	T _{max}	x ₁	x ₂	Z ₁	Z ₂	B	d	Grösse Size
SQT 10M-12D / SQT 15M-16D	51.4010 SQT 10	1:1	6000	50	98	63	50	84	76	M1 - M10	Gr. 0, WFLK 0
SQT 15M-16D / SQT 200M-16D	51.4012 SQT 10	1:1	6000	50	107	63	50	84	76	M3 - M12	Gr. 1, WFLK 1
SQT 250M-16D											
SQT 15M-12D / SQT 18M-12D	51.4010 SQT 15	1:1	6000	50	98	63	50	84	76	M1 - M10	Gr. 0, WFLK 0
SQT 200M-12D / SQT 250M-12D	51.4012 SQT 15	1:1	6000	50	107	63	50	84	76	M3 - M12	Gr. 1, WFLK 1

Axial Fräskopf

versetzt

Axial milling head

offset

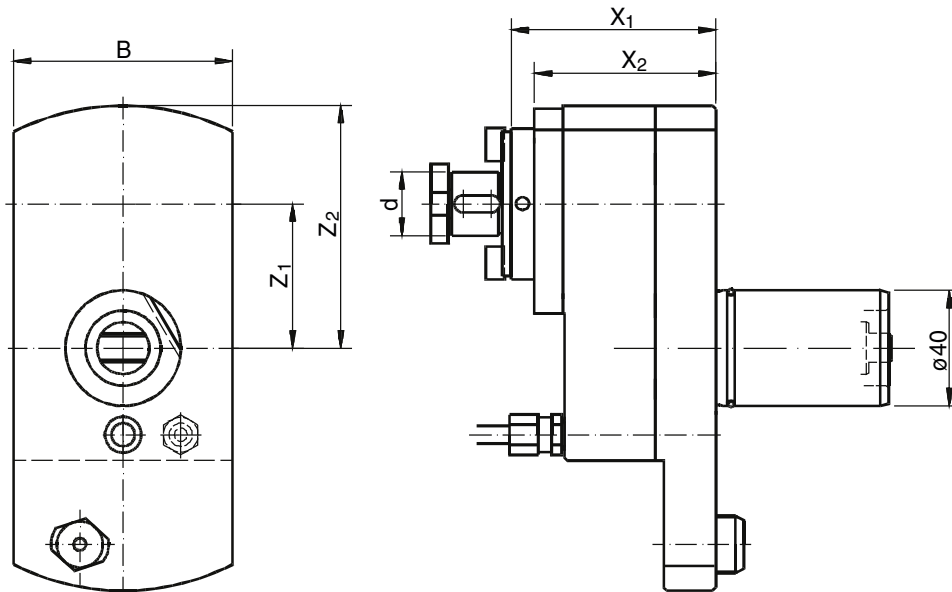

Maschinentyp	Nr. / No.	i	n _{max}	T _{max}	x ₁	x ₂	Z ₁	Z ₂	B	d
SQT 10M-12D	52.4016 SQT 10	1:1	6000	50	93	63	50	84	76	16
SQT 15M-16D										
SQT 15M-16D										
SQT 200M-16D	52.4022 SQT 10	1:1	6000	50	95	63	50	84	76	22
SQT 250M-16D										
SQT 15M-12D	52.4016 SQT 15	1:1	6000	50	93	63	50	84	76	16
SQT 18M-12D										
SQT 200M-12D	52.4022 SQT 15	1:1	6000	50	95	63	50	84	76	22
SQT 250M-12D										

Axial Fräskopf

versetzt, modular

Axial milling head

offset, modular

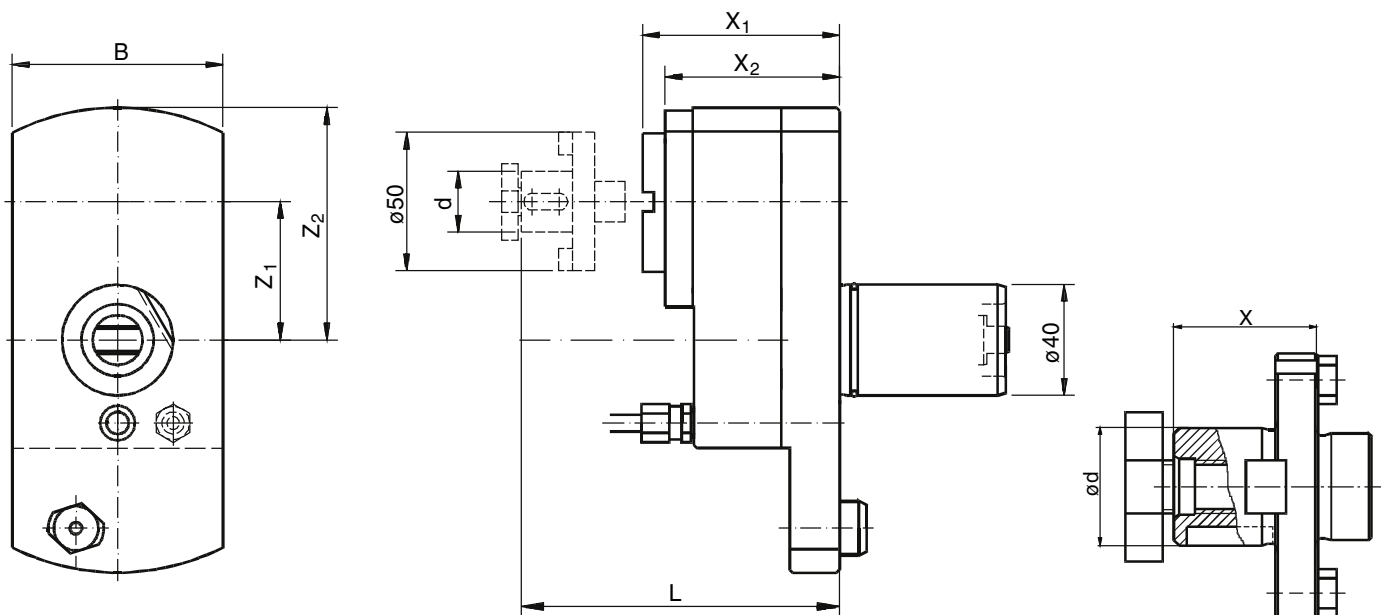

Maschinentyp	Nr. / No.	i	n _{max}	T _{max}	x ₁	x ₂	Z ₁	Z ₂	L	d
SQT 10M-12D	52.4000 SQT 10	1:1	6000	50	71	63	50	84	X1 + x	
SQT 15M-16D										
SQT 15M-16D										
SQT 200M-16D	52.4000 L SQT 10	1:1	6000	50	103	63	50	84	X1 + x	
SQT 250M-16D										
SQT 15M-12D	52.4000 SQT 15	1:1	6000	50	71	63	50	84	X1 + x	
SQT 18M-12D										
SQT 200M-12D	52.4000 L SQT 15	1:1	6000	50	103	63	50	84	X1 + x	
SQT 250M-12D										

siehe
Tabelle

Nr. / No.	d	x
501.507	13	24
501.510	16	29
501.520	22	31
501.530	27	33

Radial Bohr- und Fräskopf

Radial drilling and milling head

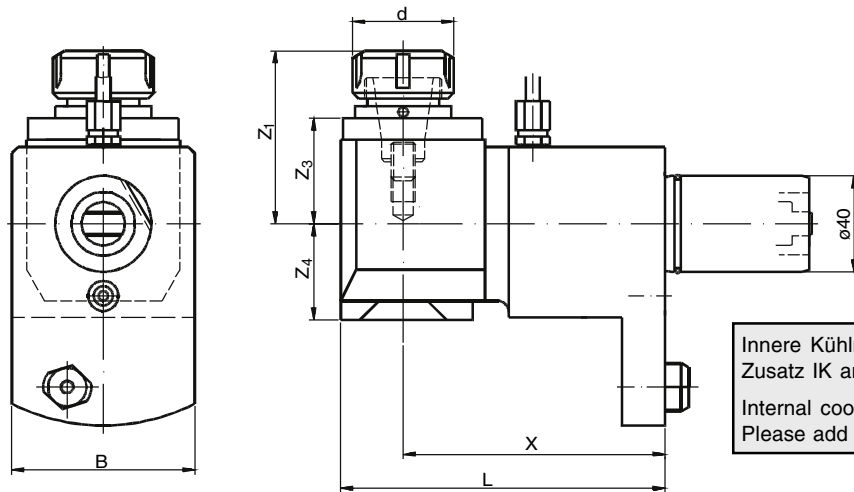

Maschinentyp	Nr. / No.	i	n _{max}	T _{max}	x	L	Z ₁	Z ₃	Z ₄	B	d	Spannzange Collet
SQT 10M-12D SQT 15M-16D SQT 200M-16D SQT 250M-16D	60.4025 SQT 10	1:1	6000	50	109	135	72	44	40	76	42	RD/ER 25 430E (2-16)
	60.4032 SQT 10	1:1	6000	50	109	135	80	48	53	76	50	RD/ER 32 470E (3-20)
	60.4025 SQT 10 IK	1:1	6000	50	109	135	72	44	---	76	42	RD/ER 25 430E (2-16)
	60.4032 SQT 10 IK	1:1	6000	50	109	135	80	48	72	76	50	RD/ER 32 470E (3-20)
	60.4020 SQT 10 I1	1:2	12000	25	109	135	65	35	40	76	35	RD/ER 20 428E (2-13)
	60.4025 SQT 10 I2	2:1	3000	60	109	135	65	35	40	76	42	RD/ER 25 430E (2-16)
SQT 15M-12D SQT 18M-12D SQT 200M-12D SQT 250M-12D	60.4025 SQT 15	1:1	6000	50	130	168	72	44	40	76	42	RD/ER 25 430E (2-16)
	60.4032 SQT 15	1:1	6000	50	130	168	80	48	53	76	50	RD/ER 32 470E (3-20)
	60.4025 SQT 15 IK	1:1	6000	50	130	168	72	44	---	76	42	RD/ER 25 430E (2-16)
	60.4032 SQT 15 IK	1:1	6000	50	130	168	80	48	72	76	50	RD/ER 32 470E (3-20)
	60.4032 SQT 15 I1	1:2	12000	25	130	168	---	---	---	76	50	RD/ER 32 470E (3-20)
	60.4016 SQT 15 I133	1:1,33	12000	38	130	168	---	---	---	76	32	RD/ER 16 426E (1-10)
60.5040 SQT 28	1:1	4000	80	---	---	---	---	---	---	63	RD/ER 40 472E (4-26)	

Radial Bohr- und Fräskopf

für 1. und 2. Spindel

Radial drilling and milling head

for 1st and 2nd spindle

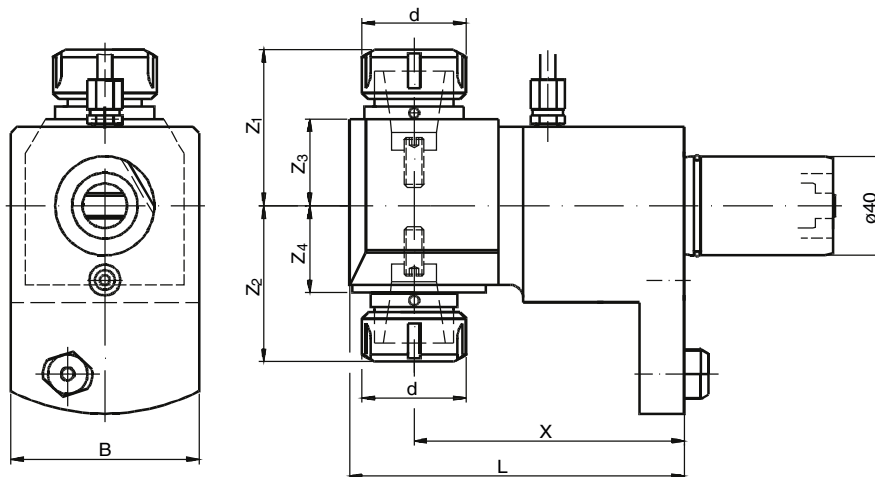

Maschinentyp	Nr. / No.	i	n _{max}	T _{max}	x	L	Z ₁	Z ₂	Z ₃	Z ₄	B	d	Spannzange Collet
SQT 10MS-12D SQT 15MS-16D SQT 200MS-16D SQT 250MS-16D	60.4025 DSQT 10	1:1	6000	50	109	135	63	63	32	32	76	42	RD/ER 25 430E (2-16)
SQT 15MS-12D SQT 18MS-12D SQT 200MS-12D SQT 250MS-12D	60.4032 DSQT 15	1:1	6000	50	130	168	81	81	48	48	76	50	RD/ER 32 470E (3-20)

Radial Bohr- und Fräskopf, achsversetzt für 1. und 2. Spindel

Radial drilling and milling head, offset
for 1st and 2nd spindle

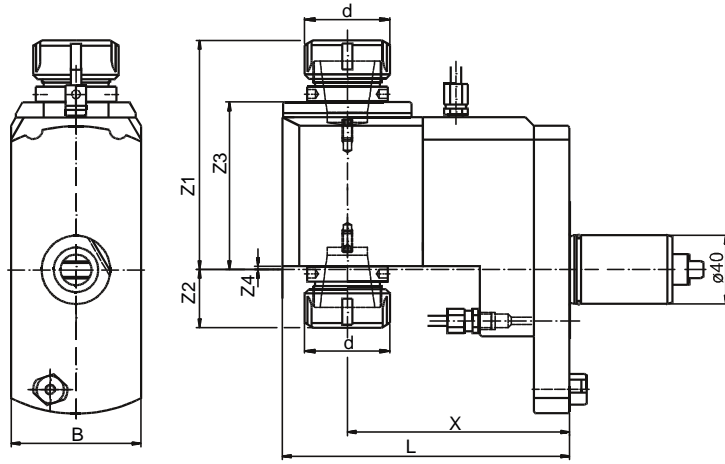

Maschinentyp	Nr. / No.	i	n_{max}	T_{max}	x	L	Z ₁	Z ₂	Z ₃	Z ₄	B	d	Spannzange Collet
SQT 10MS-12D SQT 15MS-16D SQT 200MS-16D SQT 250MS-16D	80.4025 DSQT 10	1:1	6000	50	109	135	117	84	67	-15	76	42	RD/ER 25 430E (2-16)
SQT 15MS-12D SQT 18MS-12D SQT 200MS-12D SQT 250MS-12D	80.4032 DSQT 15	1:1	6000	50	130	168	131	31	98	-2	76	50	RD/ER 32 470E (3-20)

Radial Bohr- und Fräskopf, achsversetzt für 2. Spindel

Radial drilling and milling head, offset
for 2nd spindle

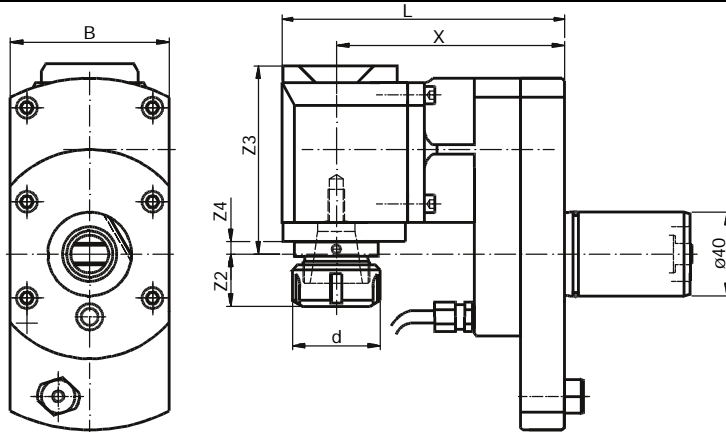

Maschinentyp	Nr. / No.	i	n_{max}	T_{max}	x	L	Z ₁	Z ₄	B	d	Spannzange Collet
SQT 10MS-12D SQT 15MS-16D SQT 200MS-16D SQT 250MS-16D	80.4025 SQT 10 L	1:1	6000	50	109	135	25	-15	76	42	RD/ER 25 430E (2-16)
SQT 15MS-12D SQT 18MS-12D SQT 200MS-12D SQT 250MS-12D	80.4032 SQT 15 L	1:1	6000	50	130	168	34	-2	76	50	RD/ER 32 470E (3-20)

Radial Bohr- und Fräskopf für 2. Spindel

Radial drilling and milling head
for 2nd spindle

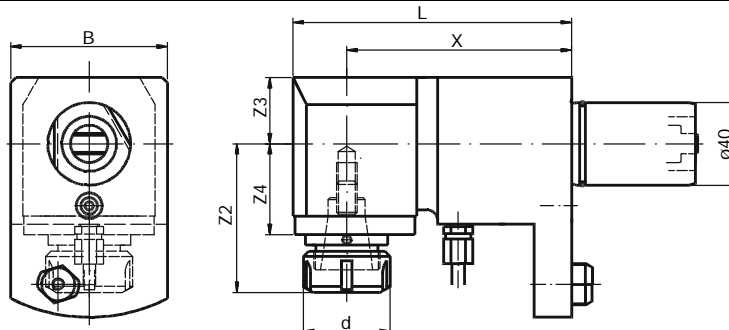

Maschinentyp	Nr. / No.	i	n_{max}	T_{max}	x	L	Z ₂	Z ₃	Z ₄	B	d	Spannzange Collet
SQT 10MS-12D SQT 15MS-16D	60.4025 SQT 10 L	1:1	6000	50	109	135	72	40	44	76	42	RD/ER 25 430E (2-16)
SQT 200MS-16D SQT 250MS-16D	60.4032 SQT 10L	1:1	6000	50	109	135	80	53	48	76	50	RD/ER 32 470E (3-20)
SQT 15MS-12D SQT 18MS-12D	60.4025 SQT 15 L	1:1	6000	50	130	168	72	40	44	76	42	RD/ER 25 430E (2-16)
SQT 200MS-12D SQT 250MS-12D	60.4032 SQT 15 L	1:1	6000	50	130	168	80	53	48	76	50	RD/ER 32 470E (3-20)

Radial Bohr- und Fräskopf

Radial drilling and milling head

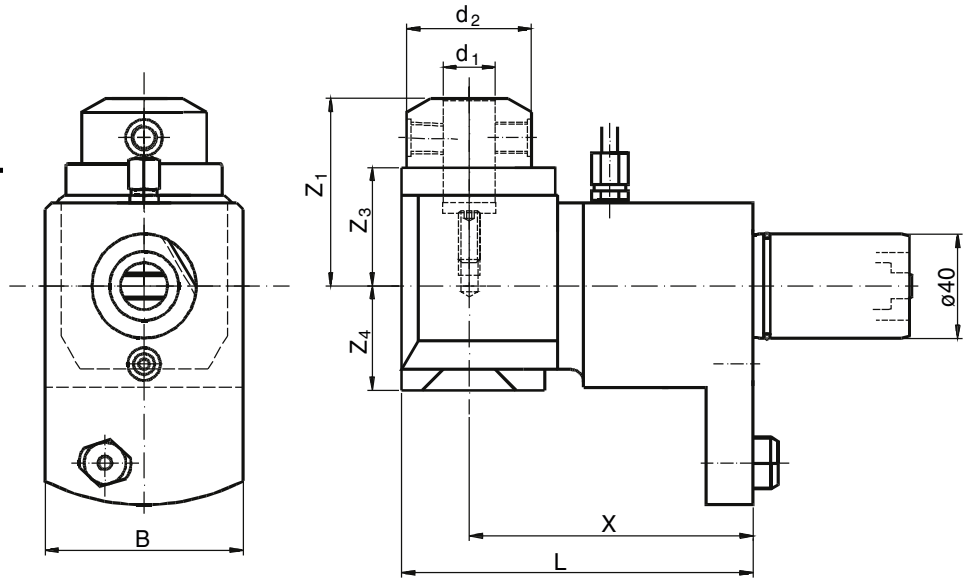

Andere \varnothing auf Anfrage.
Other \varnothing on request.

WN-Reduzierhülsen auf Anfrage.
WN-reducing sleeves on request.

Maschinentyp	Nr. / No.	i	n_{max}	T_{max}	x	L	Z_1	Z_3	Z_4	B	d_1	d_2
SQT 10M-12D SQT 15M-16D SQT 15M-16D	60.4020 WN SQT 10	1:1	6000	50	109	135	72	46	40	76	20	48
SQT 200M-16D SQT 250M-16D	60.4020 WN SQT 10 IK	1:1	6000	50	109	135	72	46	59	76	20	48
SQT 15M-12D SQT 18M-12D	60.4020 WN SQT 15	1:1	6000	50	130	168	87	62	54	76	20	52
SQT 200M-12D SQT 250M-12D	60.4020 WN SQT 15 IK	1:1	6000	50	130	168	87	62	72	76	20	52

Radial Gewinde-Bohrkopf

Radial tapping head

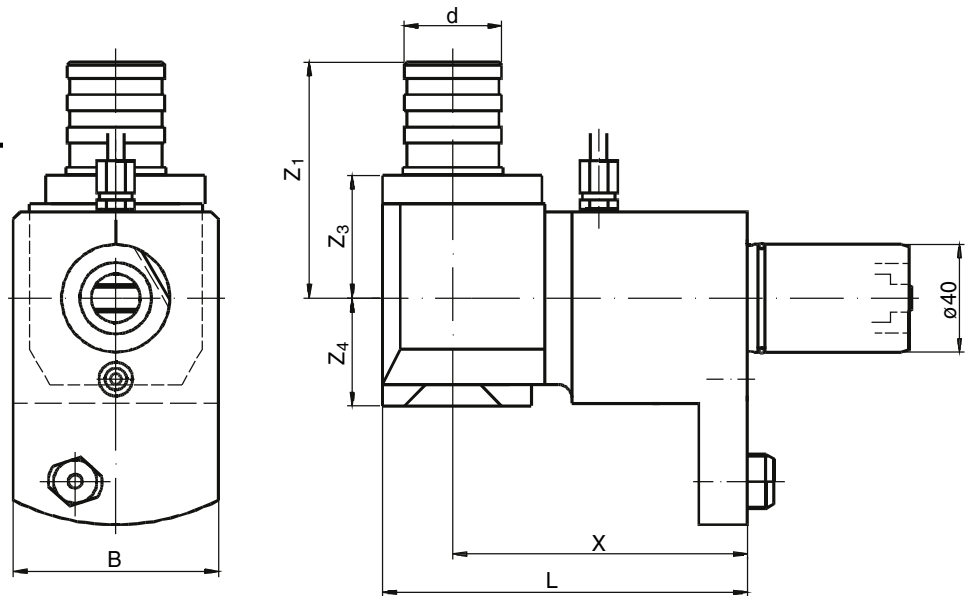

Maschinentyp	Nr. / No.	i	n_{max}	T_{max}	x	L	Z_1	Z_3	Z_4	B	d	Grösse Size
SQT 10M-12D SQT 15M-16D SQT 15M-16D	61.4010 SQT 10	1:1	6000	50	109	135	79	46	41	76	M1 - M10	Gr. 0, WFLK 0
SQT 200M-16D SQT 250M-16D	61.4012 SQT 10	1:1	6000	50	109	135	88	46	41	76	M3 - M12	Gr. 1, WFLK 1
SQT 15M-12D SQT 18M-12D	61.4010 SQT 15	1:1	6000	50	130	135	81	48	53	76	M1 - M10	Gr. 0, WFLK 0
SQT 200M-12D SQT 250M-12D	61.4012 SQT 15	1:1	6000	50	130	135	90	48	53	76	M3 - M12	Gr. 1, WFLK 1

Radial Fräskopf

Radial milling head

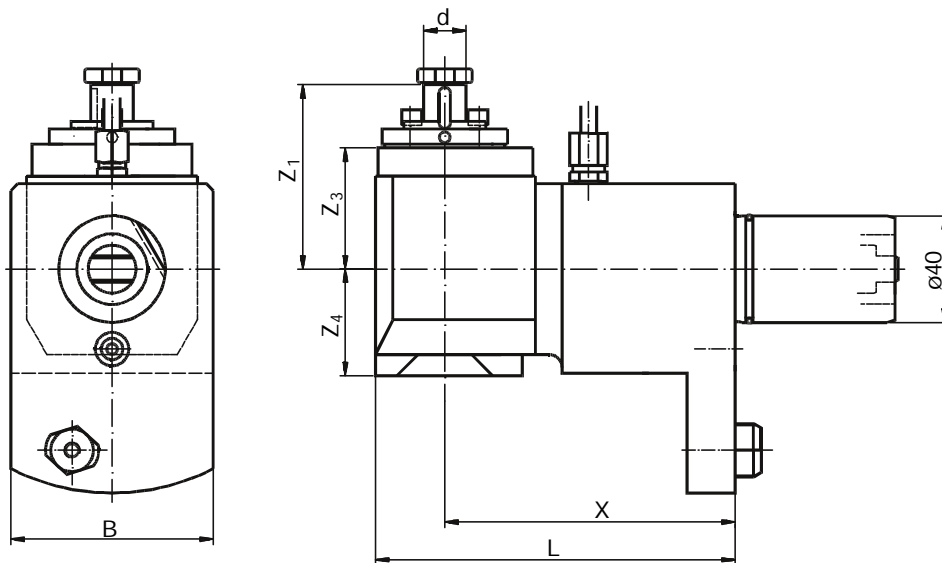

Maschinentyp	Nr. / No.	i	n_{max}	T_{max}	x	L	Z ₁	Z ₃	Z ₄	B	d
SQT 10M-12D	62.4013 SQT 10	1:1	6000	50	109	135	74	44	40	76	13
SQT 15M-16D	62.4016 SQT 10	1:1	6000	50	109	135	74	44	40	76	16
SQT 200M-16D	62.4022 SQT 10	1:1	6000	50	109	135	76	46	40	76	22
SQT 250M-16D	62.4022 SQT 10	1:1	6000	50	109	135	76	46	40	76	22
SQT 15M-12D	62.4016 SQT 15	1:1	6000	50	130	168	77	48	53	76	16
SQT 18M-12D	62.4016 SQT 15	1:1	6000	50	130	168	77	48	53	76	16
SQT 200M-12D	62.4022 SQT 15	1:1	6000	50	130	168	79	48	53	76	22
SQT 250M-12D	62.4022 SQT 15	1:1	6000	50	130	168	79	48	53	76	22

Schwenkkopf
± 105°

Swivel head
± 105°

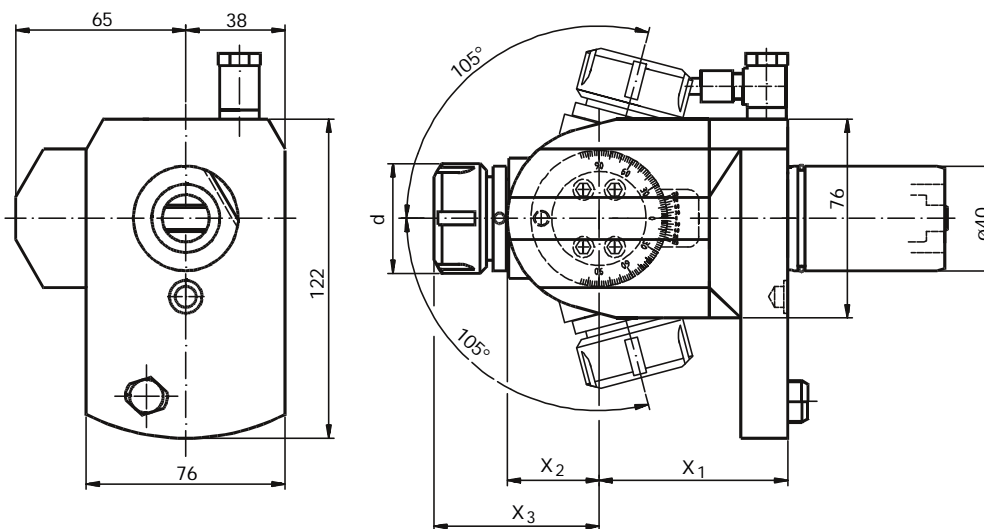

Maschinentyp	Nr. / No.	i	n_{max}	T_{max}	x ₁	x ₂	x ₃	d	Spannzange Collet
SQT 10M-12D	63.4025 K SQT 10	1:1	6000	32	72	35	63	42	RD/ER 25 430E (2-16)
SQT 15M-16D	63.4025 K SQT 10	1:1	6000	32	72	35	63	42	RD/ER 25 430E (2-16)
SQT 200M-16D	63.4025 L SQT 10	1:1	6000	32	95	35	63	42	RD/ER 25 430E (2-16)
SQT 250M-16D	63.4025 L SQT 10	1:1	6000	32	95	35	63	42	RD/ER 25 430E (2-16)
SQT 15M-12D	63.4025 K SQT 15	1:1	6000	32	72	35	63	42	RD/ER 25 430E (2-16)
SQT 18M-12D	63.4025 L SQT 15	1:1	6000	32	122	35	63	42	RD/ER 25 430E (2-16)
SQT 200M-12D	63.4025 SQT 15 X 95	1:1	6000	32	95	35	63	42	RD/ER 25 430E (2-16)
SQT 250M-12D	63.4025 SQT 15 X 95	1:1	6000	32	95	35	63	42	RD/ER 25 430E (2-16)

Radial Scheibenfräserkopf

Radial drilling head for side milling cutters

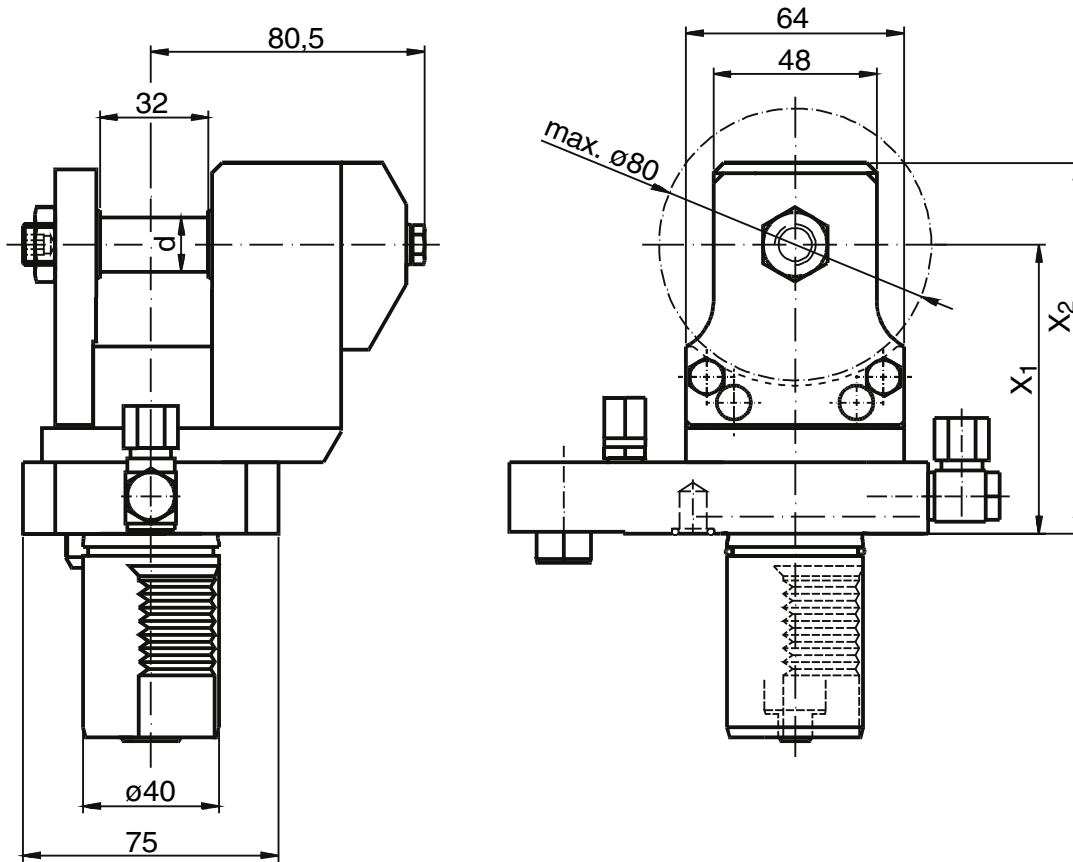

SQT-Serie							
Maschinentyp	Nr. / No.	i	n_{max}	T_{max}	x_1	x_2	d
SQT 10M-12D	64.4010 SQT 10	3:1	6000	50	85	109	10
SQT 15M-16D	64.4013 SQT 10	3:1	6000	50	85	109	13
SQT 15M-16D	64.4016 SQT 10	3:1	6000	50	85	109	16
SQT 200M-16D	64.4022 SQT 10	3:1	6000	50	85	109	22
SQT 250M-16D	64.4010 SQT 15	3:1	6000	50	135	109	10
SQT 15M-12D	64.4013 SQT 15	3:1	6000	50	135	109	13
SQT 18M-12D	64.4016 SQT 15	3:1	6000	50	135	109	16
SQT 200M-12D	64.4022 SQT 15	3:1	6000	50	135	109	22

MP-Serie							
Maschinentyp	Nr. / No.	i	n_{max}	T_{max}	x_1	x_2	d
MP 410N-12D	64.4010 MP 610	3:1	6000	50	85	109	10
MP 415N-12D	64.4013 MP 610	3:1	6000	50	85	109	13
MP 610-12D	64.4016 MP 610	3:1	6000	50	85	109	16
MP 6200-16D	64.4010 MP 620	3:1	6000	50	135	109	10
MP 420N-12D	64.4013 MP 620	3:1	6000	50	135	109	13
MP 620-12D	64.4016 MP 620	3:1	6000	50	135	109	16

Axial Bohr- und Fräskopf

Axial drilling and milling head

für MP 630 / MP 6300 auf Anfrage
for MP 630 / MP 6300 on request

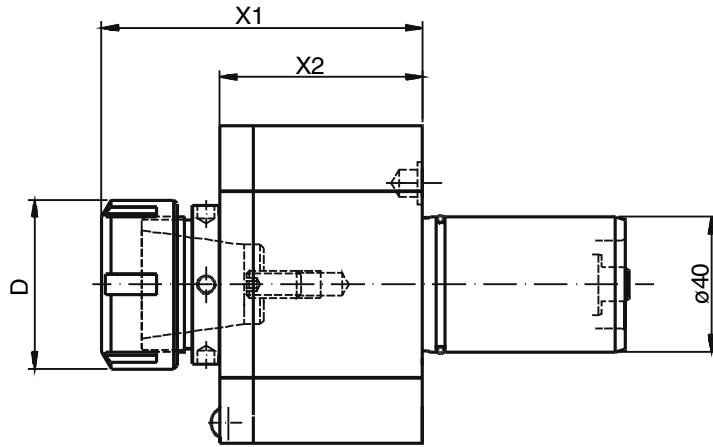
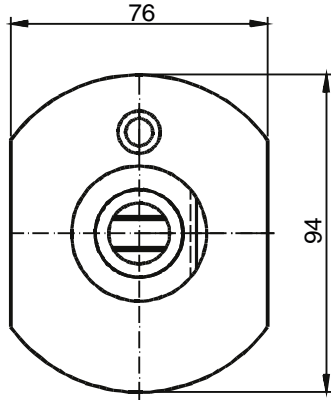

Innere Kühlmittelzufuhr: Zusatz IK an Bestellnummer anfügen
Internal cooling supply: Please add IK behind order no.

Auch als y-verstellbar verfügbar
Also then y-axis adjustable available

Maschinentyp	Nr. / No.	i	n _{max}	T _{max}	X1	X2	D	Spannzange Collet
MP 410 N - 12D MP 415 N - 12D MP 610 - 12D MP 6200 - 16D	40.4025 MP610	1:1	6000	50	92	60	42	RD/ER 25 430E (2-16)
MP 420 N - 12D MP 620 - 12D MP 620 N - 12D MP 6200 - 12D	40.4032 MP620	1:1	6000	50	95	60	50	RD/ER 32 470E (3-20)

Axial Fräskopf modular

Axial milling head modular

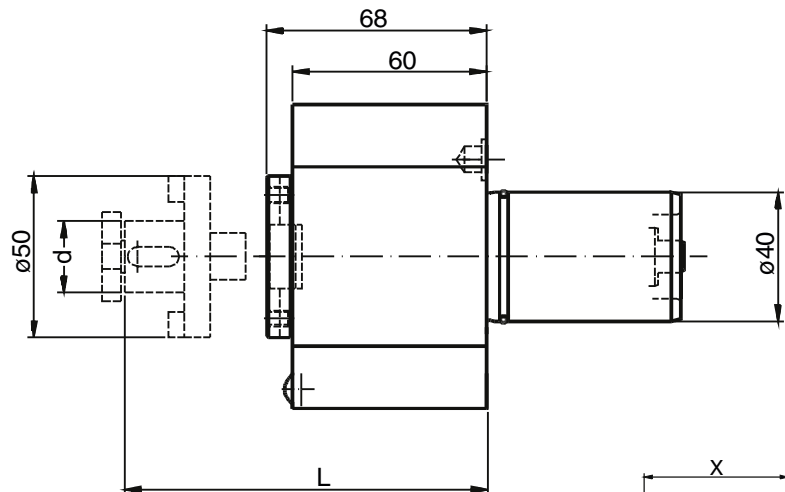
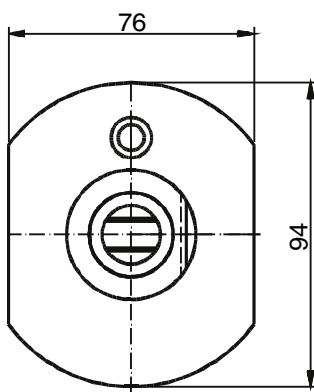

Maschinentyp	Nr. / No.	i	n _{max}	T _{max}	L	d
MP 410 N - 12D MP 415 N - 12D MP 610 - 12D MP 6200 - 16D	42.4000 MP610	1:1	6000	50	68 + X	siehe Tabelle
MP 420 N - 12D MP 620 - 12D MP 620 N - 12D MP 6200 - 12D	42.4000 MP620	1:1	6000	50	68 + X	

Nr. / No.	d	x
501.507	13	24
501.510	16	29
501.520	22	31
501.530	27	33

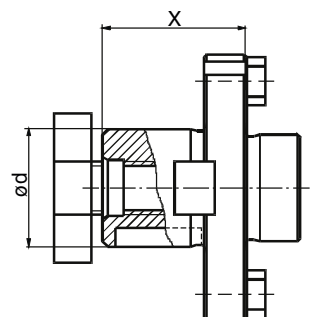

Axial Bohr- und Fräskopf, versetzt

Axial drilling and milling head, offset

für MP 630 / MP 6300 auf Anfrage
for MP 630 / MP 6300 on request

Innere Kühlmittelzufuhr:
Zusatz IK an Bestellnummer anfügen
Internal cooling supply:
Please add IK behind order no.

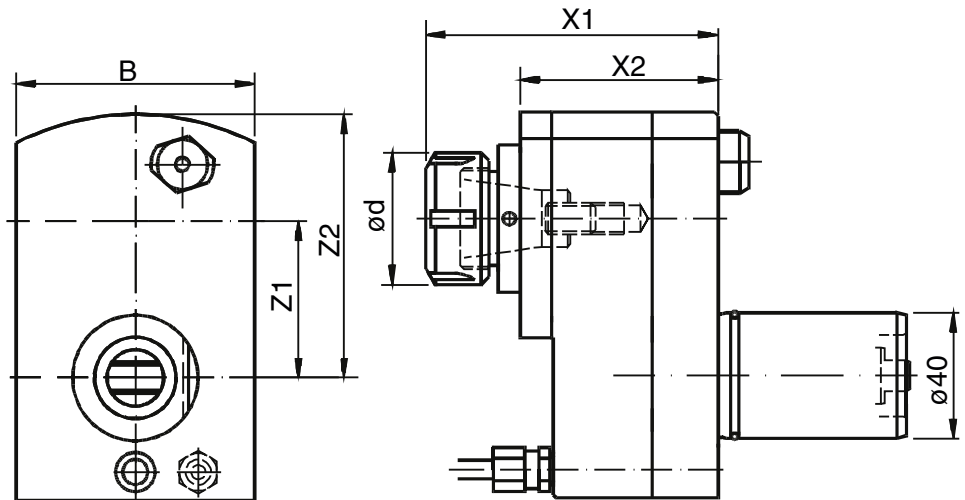

Maschinentyp	Nr. / No.	i	n _{max}	T _{max}	X1	X2	Z1	Z2	B	d	Spannzange Collet
MP 410 N - 12D	50.4025 MP610	1:1	6000	50	93	63	50	84	76	42	RD/ER 25 430E (2-16)
	50.4032 MP610		6000		95						50
MP 415 N - 12D	50.4025 MP610 IK	1:1	6000	50	120	120	50	84	76	42	RD/ER 25 430E (2-16)
MP 610 - 12D	50.4032 MP610 IK				122						50
MP 6200 - 16D	50.4025 MP610 I1	1:2	12000	8	120	80	50	84	76	42	RD/ER 25 430E (2-16)
	50.5025 MP610 IK I1										120
MP 420 N - 12D	50.4025 MP620	1:1	6000	50	104	65	50	84	76	42	RD/ER 25 430E (2-16)
	50.4032 MP 620				107						50
MP 620 - 12D	50.4025 MP620 IK	1:1	6000	50	120	80	50	84	76	42	RD/ER 25 430E (2-16)
MP 620 N - 12D	50.4032 MP620 IK	1:1	6000	50	122						50
MP 6200 - 12D	50.4032 MP620 IK I1	1:2	12000	120	122	80	50	84	76	50	RD/ER 32 470E (3-20)
	50.4025 MP620 I1										1:2
	50.4032 MP620 I1751	1,75:1	3000	60	122	80	50	84	76	50	RD/ER 32 470E (3-20)

Axial Gewindebohrkopf

Axial tapping head

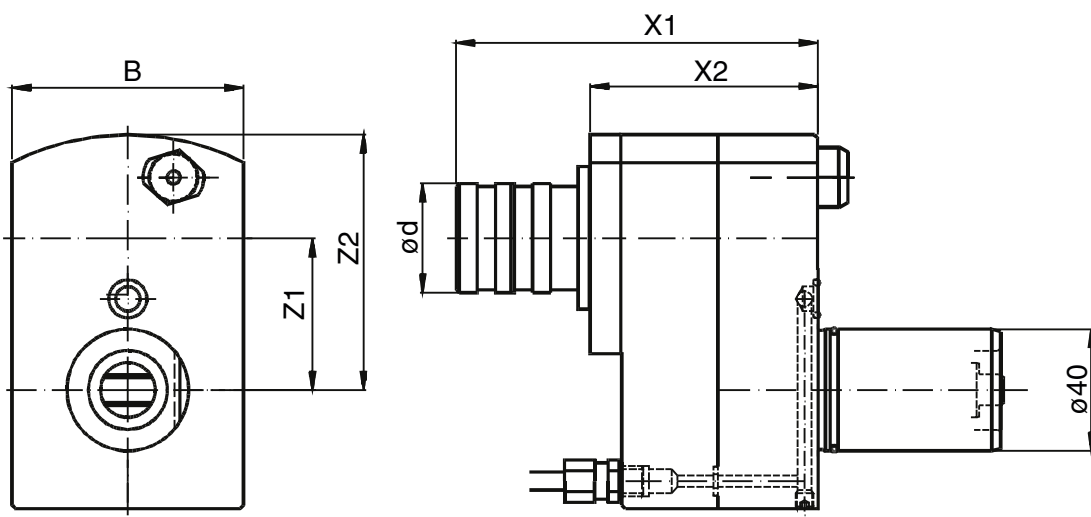

Maschinentyp	Nr. / No.	i	n _{max}	T _{max}	X1	X2	Z1	Z2	B	d	Größe / Size
MP 410 N - 12D	51.4010 MP610	1:1	6000	50	110	75	50	84	76	M1 - M10	Gr. 0, WFLK 0
MP 415 N - 12D											
MP 610 - 12D	51.4012 MP610	1:1	6000	50	119	75	50	84	76	M3 - M12	Gr. 1, WFLK 1
MP 6200 - 16D											
MP 420 N - 12D	51.4010 MP620	1:1	6000	50	110	75	50	84	76	M1 - M10	Gr. 0, WFLK 0
MP 620 - 12D											
MP 620 N - 12D	51.4012 MP620	1:1	6000	50	119	75	50	84	76	M3 - M12	Gr. 1, WFLK 1
MP 6200 - 12D											

Axial Fräskopf versetzt

Axial milling head offset

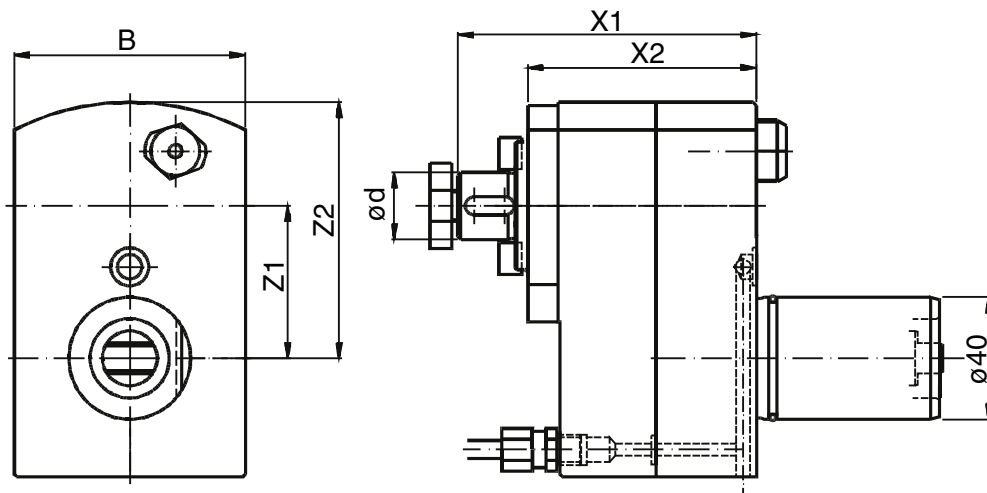

Maschinentyp	Nr. / No.	i	n_{max}	T_{max}	X1	X2	Z1	Z2	B	d
MP 410 N - 12D	52.4016 MP610	1:1	6000	50	93	63	50	84	76	16
MP 415 N - 12D										
MP 610 - 12D	52.4022 MP610	1:1	6000	50	95	63	50	84	76	22
MP 6200 - 16D										
MP 420 N - 12D	52.4016 MP620	1:1	6000	50	93	63	50	84	76	16
MP 620 - 12D										
MP 620 N - 12D	52.4022 MP620	1:1	6000	50	95	63	50	84	76	22
MP 6200 - 12D										

Axial Fräskopf versetzt, modular

Axial milling head offset, modular

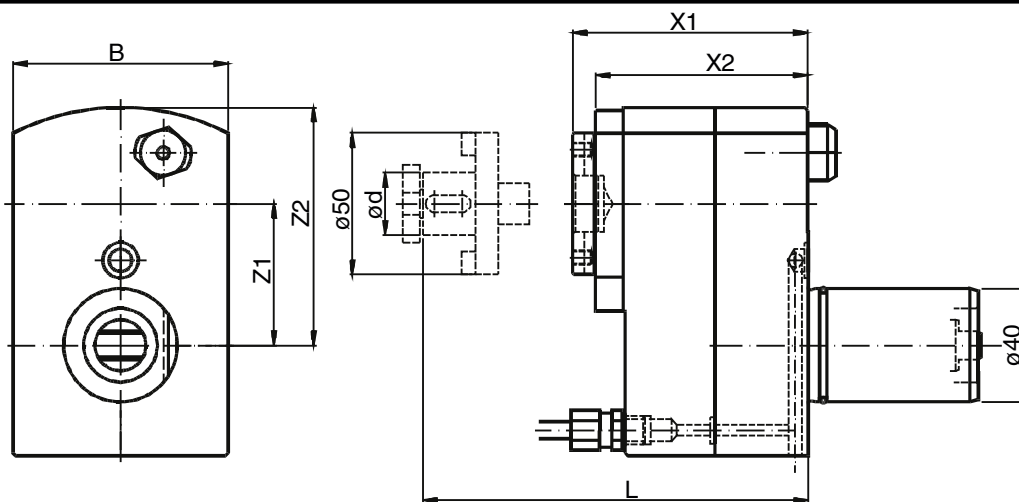

Maschinentyp	Nr. / No.	i	n_{max}	T_{max}	X1	X2	Z1	Z2	L	d
MP 410 N - 12D	52.4000 K MP610	1:1	6000	50	71	63	50	84	X1 + x	
MP 415 N - 12D										
MP 610 - 12D	52.4000 L MP610	1:1	6000	50	103	63	50	84	X1 + x	
MP 6200 - 16D										
MP 420 N - 12D	52.4000 K MP620	1:1	6000	50	71	63	50	84	X1 + x	
MP 620 - 12D										
MP 620 N - 12D	52.4000 L MP620	1:1	6000	50	103	63	50	84	X1 + x	
MP 6200 - 12D										

siehe
Tabelle

Nr. / No.	d	x
501.507	13	24
501.510	16	29
501.520	22	31
501.530	27	33

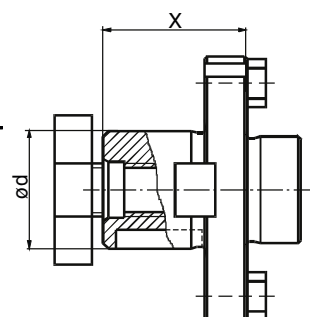

Radial Bohr- und Fräskopf

Radial drilling and milling head

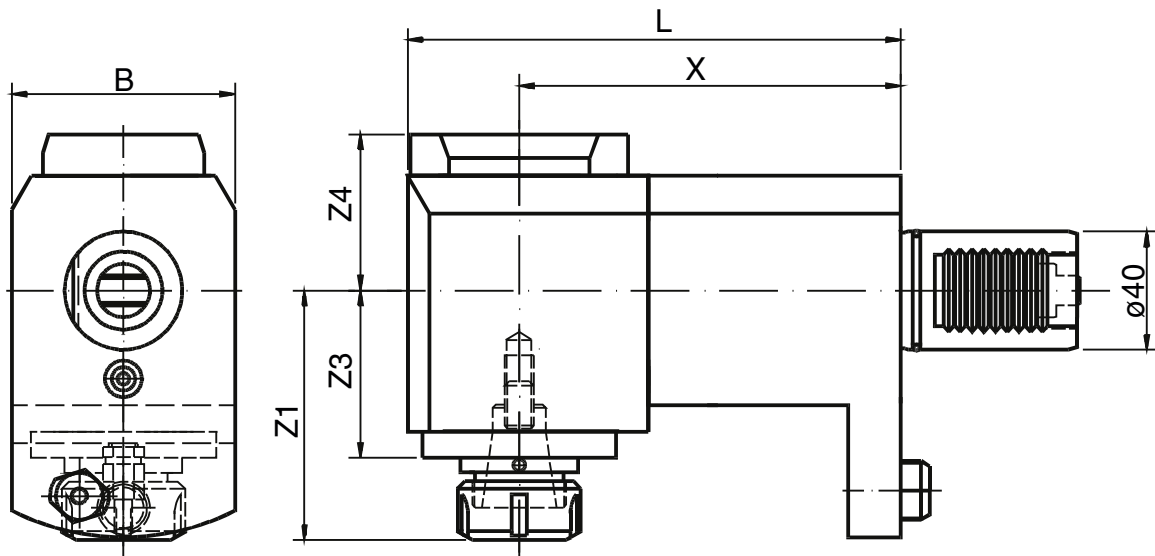

Innere Kühlmittelzufuhr: Zusatz IK an Bestellnummer anfügen
Internal cooling supply: Please add IK behind order no.

Maschinentyp	Nr. / No.	i	η_{max}	T_{max}	X	L	Z1	Z3	Z4	B	d	Spannzange Collet
MP 410 N - 12D	60.4025 MP610	1:1	6000	50	110	135	72	44	40	76	42	RD/ER 25 430E (2-16)
	60.4032 MP610						80	48	53		50	RD/ER 32 470E (3-20)
MP 415 N - 12D	60.4025 MP610 IK	1:1	6000	50	110	135	72	44	---	76	42	RD/ER 25 430E (2-16)
MP 610 - 12D	60.4032 MP610 IK						80	48	72		50	RD/ER 32 470E (3-20)
MP 6200 - 16D	60.4020 MP610 I1	1:2	12000	25	110	135	65	35	40	76	35	RD/ER 20 428E (2-13)
	60.4025 MP610 I2	2:1	3000	60			42	RD/ER 25 430E (2-16)				
MP 420 N - 12D	60.4025 MP620	1:1	6000	50	130	168	72	44	40	76	42	RD/ER 25 430E (2-16)
	60.4032 MP620						80	48	53		50	RD/ER 32 470E (3-20)
MP 620 - 12D	60.4025 MP620 IK	1:1	6000	50	130	168	72	44	---	76	42	RD/ER 25 430E (2-16)
MP 620 N - 12D	60.4032 MP620 IK						80	48	72		50	RD/ER 32 470E (3-20)
MP 6200 - 12D	60.4020 MP620 I1	1:2	12000	25	130	168	---	---	---	76	35	RD/ER 20 428E (2-13)
	60.4032 MP620 I2	2:1	3000	60			50	RD/ER 32 470E (3-20)				
	60.4016 MP620 IK I1	1:2	12000	8	130	168	---	---	---	76	32	RD/ER 16 426E (1-10)
	60.4025 MP620 IK I1						42	RD/ER 25 430E (2-16)				
	60.4032 MP620 IK I1	50	RD/ER 32 470E (3-20)									
	60.5040 SQT 28	1:1	4000	80	---	---	---	---	---	---	63	RD/ER 40 472E (4-26)

Radial Bohr- und Fräskopf

Radial drilling and milling head

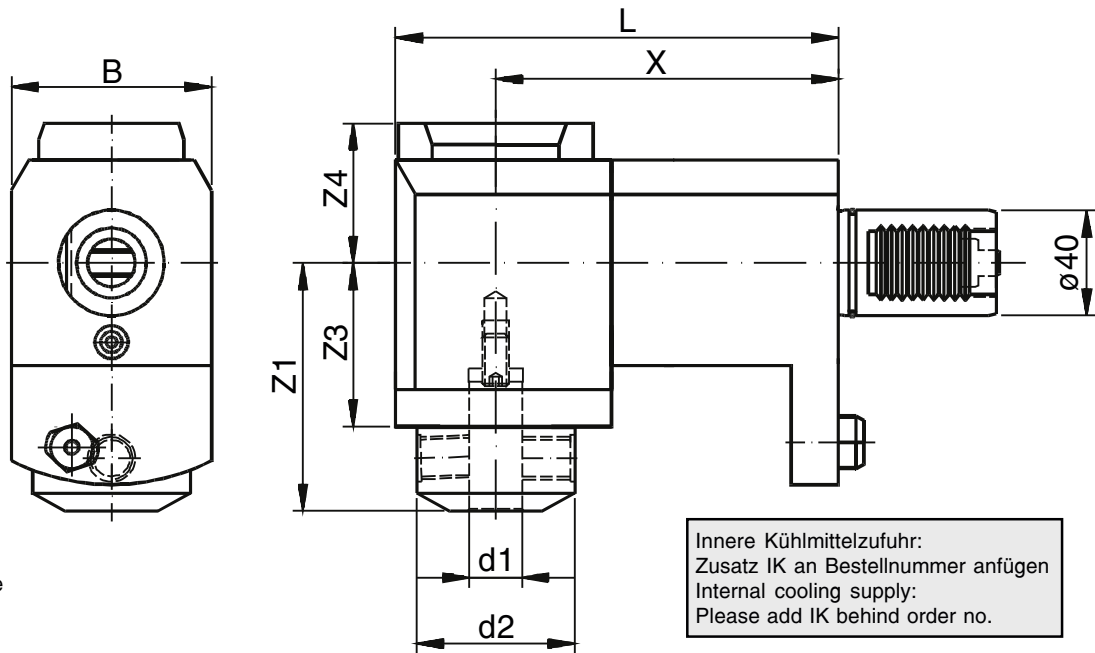

Andere ϕ auf Anfrage
Other ϕ on request

Innere Kühlmittelzufuhr:
Zusatz IK an Bestellnummer anfügen
Internal cooling supply:
Please add IK behind order no.

Maschinentyp	Nr. / No.	i	n_{max}	T_{max}	X	L	Z1	Z3	Z4	B	d1	d2
MP 410 N - 12D	60.4020 WN MP610	1:1	6000	50	110	135	72	46	40	76	20	48
MP 415 N - 12D												
MP 610 - 12D	60.4020 WN MP610 IK	1:1	6000	50	110	135	72	46	59	76	20	48
MP 6200 - 16D												
MP 420 N - 12D	60.4016 WN MP620	1:1	6000	50	130	168	87	62	54	76	20	52
MP 620 - 12D												
MP 620 N - 12D	60.4020 WN MP620	1:1	6000	50	130	168	87	62	72	76	20	52
MP 6200 - 12D												

Radial Gewinde-Bohrkopf

Radial tapping head

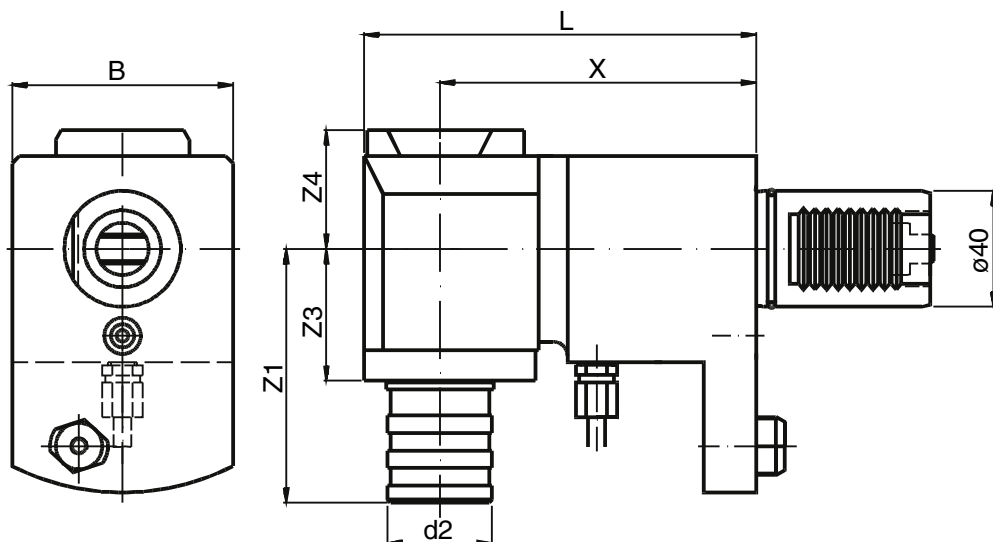

Maschinentyp	Nr. / No.	i	n_{max}	T_{max}	X	L	Z1	Z3	Z4	B	d	Größe Size
MP 410 N - 12D	61.4010 MP610	1:1	6000	50	110	135	79	46	50	76	M1 - M10	Gr. 0, WFLK 0
MP 415 N - 12D												
MP 610 - 12D	61.4012 MP610	1:1	6000	50	110	135	88	46	50	76	M3 - M12	Gr. 1, WFLK 1
MP 6200 - 16D												
MP 420 N - 12D	61.4010 MP620	1:1	6000	50	130	168	81	48	53	76	M1 - M10	Gr. 0, WFLK 0
MP 620 - 12D												
MP 620 N - 12D	61.4012 MP620	1:1	6000	50	130	168	90	48	53	76	M3 - M12	Gr. 1, WFLK 1
MP 6200 - 12D												

Radial Fräskopf

Radial milling head

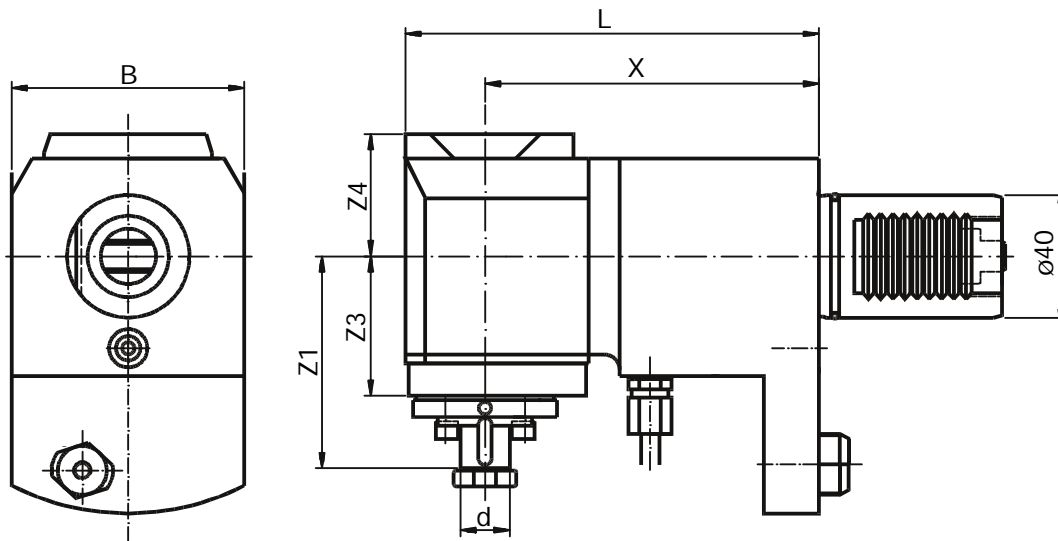

Maschinentyp	Nr. / No.	i	n_{max}	T_{max}	X	L	Z1	Z3	Z4	B	d
MP 410 N - 12D	62.4013 MP610	1:1	6000	50	110	135	74	44	40	76	13
MP 415 N - 12D	62.4016 MP610	1:1	6000	50	110	135	74	44	40	76	16
MP 610 - 12D	62.4022 MP610	1:1	6000	50	110	135	76	46	40	76	22
MP 6200 - 16D	62.4013 MP620	1:1	6000	50	130	168	77	48	53	76	13
MP 420 N - 12D	62.4016 MP620	1:1	6000	50	130	168	77	48	53	76	16
MP 620 - 12D	62.4022 MP620	1:1	6000	50	130	168	79	48	53	76	22

Schwenkkopf ± 105°

Swivel head ± 105°

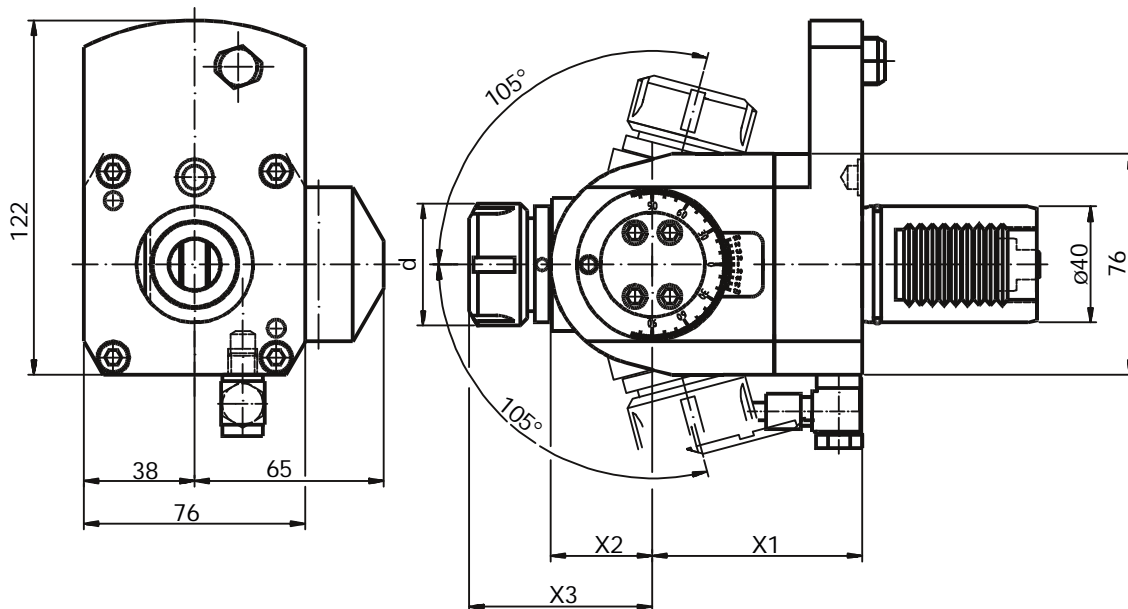

Maschinentyp	Nr. / No.	i	n_{max}	T_{max}	X1	X2	X3	d	Spannzange Collet
MP 410 N - 12D	63.4025 K MP610	1:1	6000	32	72	35	63	42	RD/ER 25 430E (2-16)
MP 415 N - 12D	63.4025 L MP610	1:1	6000	32	95	35	63	42	RD/ER 25 430E (2-16)
MP 610 - 12D	63.4025 K MP620	1:1	6000	32	72	35	63	42	RD/ER 25 430E (2-16)
MP 6200 - 16D	63.4025 L MP620	1:1	6000	32	122	35	63	42	RD/ER 25 430E (2-16)



**Statische- und angetriebene Werkzeuge für Okuma
LT10/LT200 Maschinen**

Static and driven tools for Okuma LT10/LT200 machines

Porte-outils statiques et motorisés pour machines

LT15/LT300

Drehhalter

für Hauptspindel

Turning toolholder

for main spindle

Porte outil

pour broche

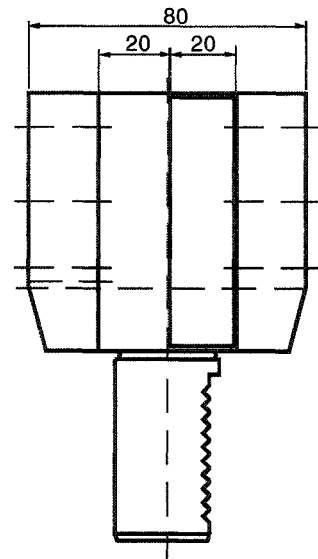
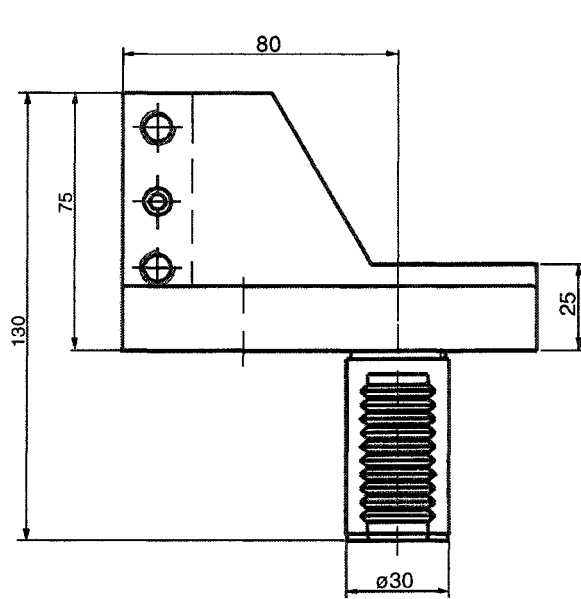

Bestell Nr
Order No.

1.3020 LT10

Drehhalter

für Haupt- und Gegenspindel

Turning toolholder

for main and subspindle

Porte outil

pour broche et contre broche

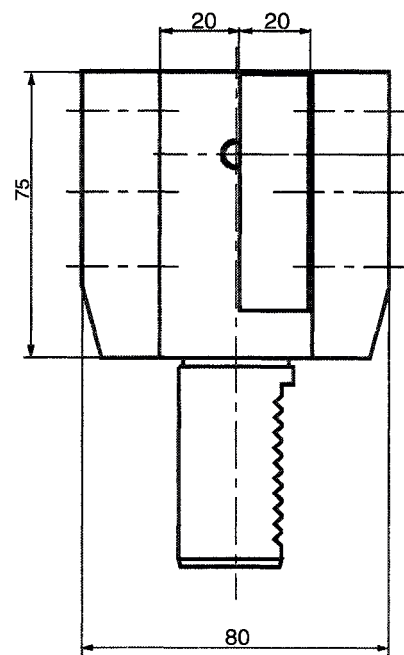
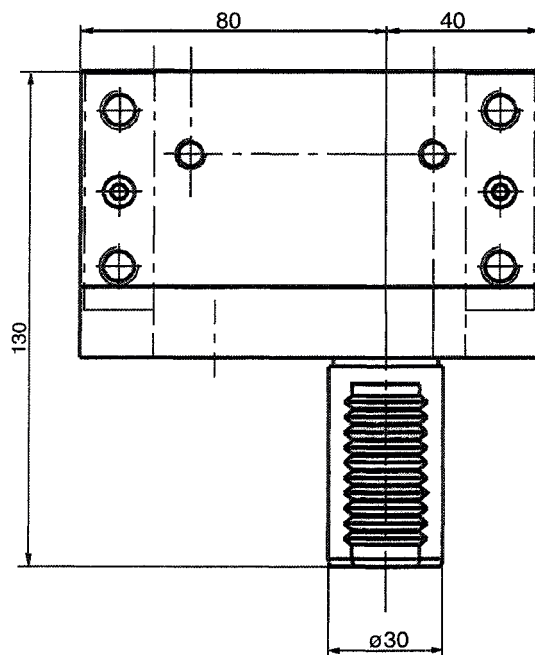

Bestell Nr
Order No.

15.3020 LT10

Bohrstangenhalter

Boring bar holder

Porte barre d'alesage

Bestell Nr Order No.	d
19.3032 LT10	32

Weitere \varnothing auf Anfrage.
Other \varnothing on request.
Autres \varnothing sur demande.

Reduzierbuchsen siehe unten.
Reducing sleeves see below.

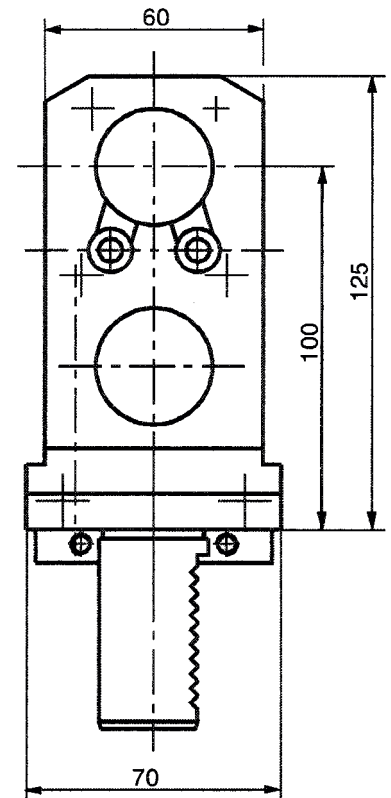
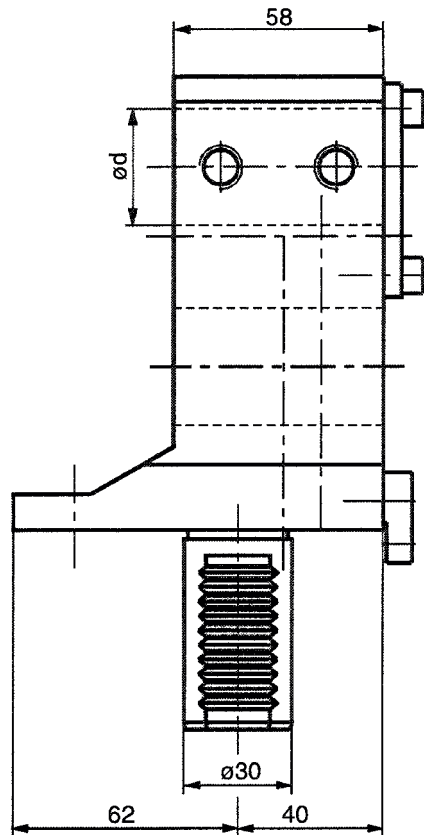

Kombihalter

für Haupt- und Gegenspindel

Combiholder

for main and subspindle

Porte-outil combiné

pour broche et contre broche

Bestell Nr Order No.	d
17.3032 LT10	32

Weitere \varnothing auf Anfrage.
Other \varnothing on request.
Autres \varnothing sur demande.

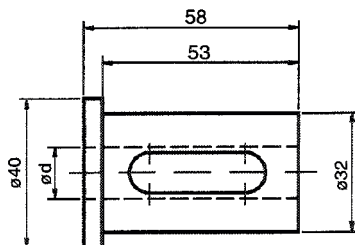

Bestell Nr Order No.	d
28.3206G200	06
28.3208G200	08
28.3210G200	10
28.3212G200	12
28.3216G200	16
28.3220G200	20
28.3225G200	25
28.3225.4G200	25,4 (1")

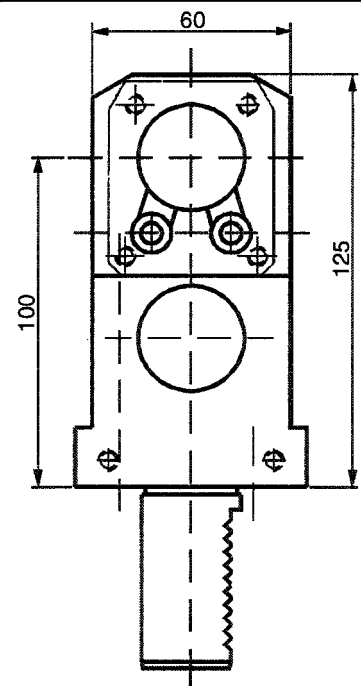
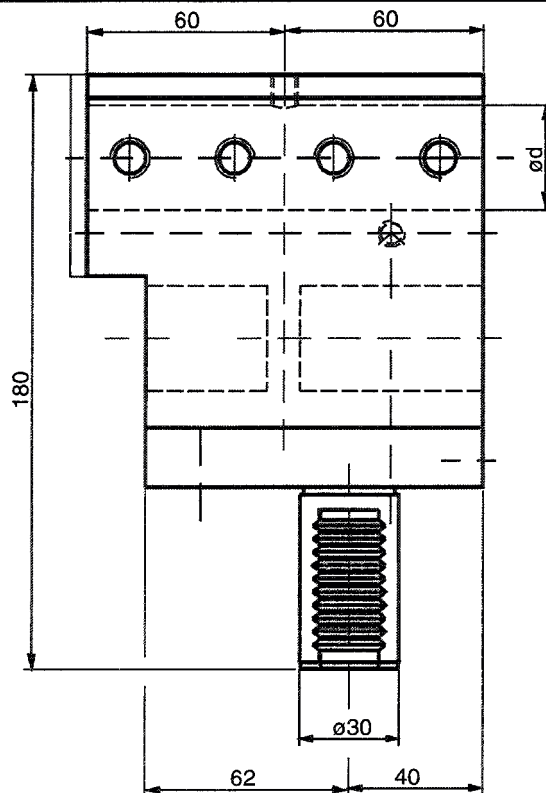

Abstechhalter

höhenverstellbar

Infeed toolholder

height adjustable

Support de plongée

hauteur réglable

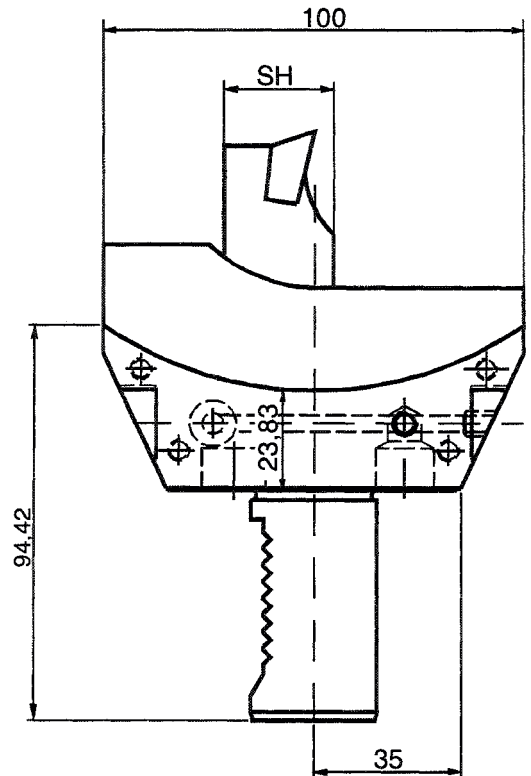
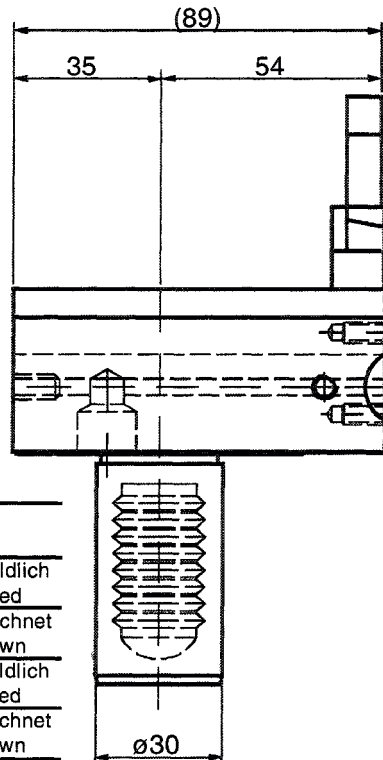

Bestell Nr Order No.	SH	
32.3026 LT10	26	spiegelbildlich inversed
32.3026 LT10 ÜK	26	wie gezeichnet as shown
32.3032 LT10	32	spiegelbildlich inversed
32.3032 LT10 ÜK	32	wie gezeichnet as shown

Plandrehhalter

Facing toolholder

**Radial porte-outil
carré**

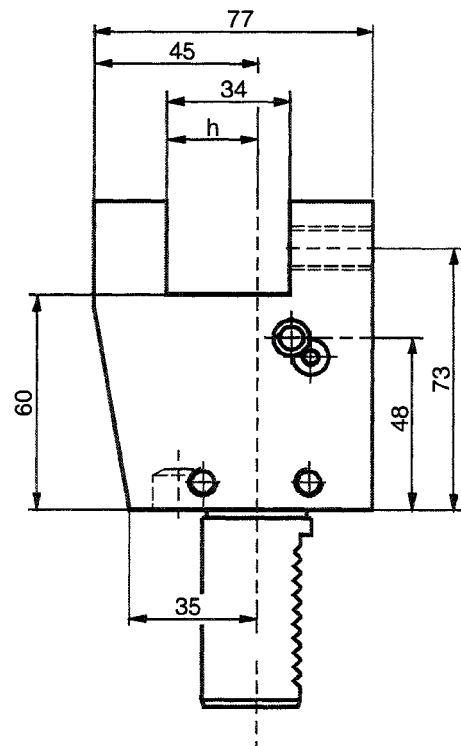
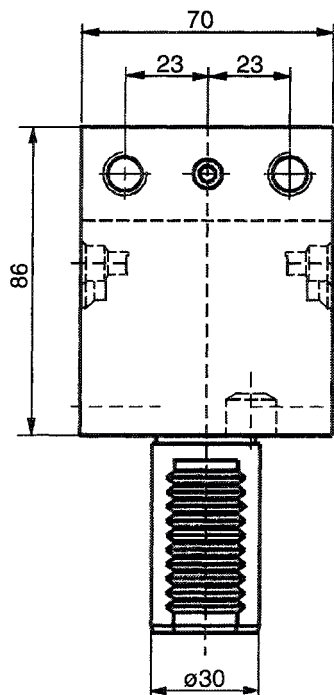

Bestell Nr Order No.	h
5.3020 LT10	20
5.3025 G300	25



Axial Bohr- und Fräskopf

Axial drilling and milling head

Tête de perçage et fraissage

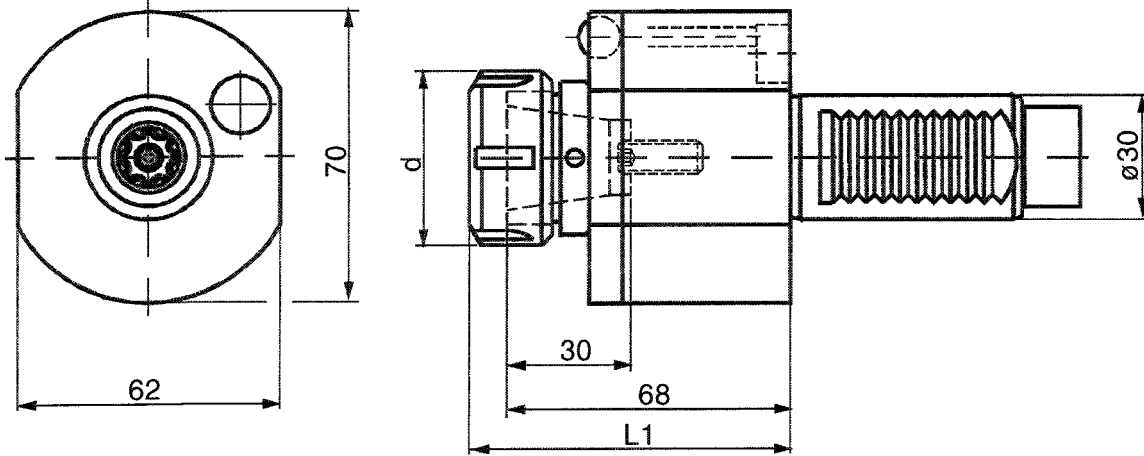

Innere Kühlmittelzufuhr; Zusatz IK an Bestellnummer anfügen
Central cooling supply; Please add IK behind order no.

Auch als y-verstellbar verfügbar
Also as y-axis adjustable available

Bestell Nr Order No.	i	L ₁	d	n _{max} [1/min]	T _{max} [Nm]	Schlüsselsatz Wrench-set	Spannzange (siehe 1.27) Collet (see 1.27)
40.3025 LT10	1:1	77	42	6000	25	Maße auf Anfrage	RD/ER 25 430E / *ET1-25 (2-16)
40.3032 LT10	1:1	90	50	6000	25		RD/ER 32 470E (3-20)
40.3016 LT10/13	1:3	85	44	18000	5		RD/ER 16 426E (1-10)
40.3016 LT10/15	1:5	93	22	25000	3		RD/ER 16 426E (1-10)

Axial Bohr- und Fräskopf

Axial drilling and milling head

Tête de perçage et fraissage

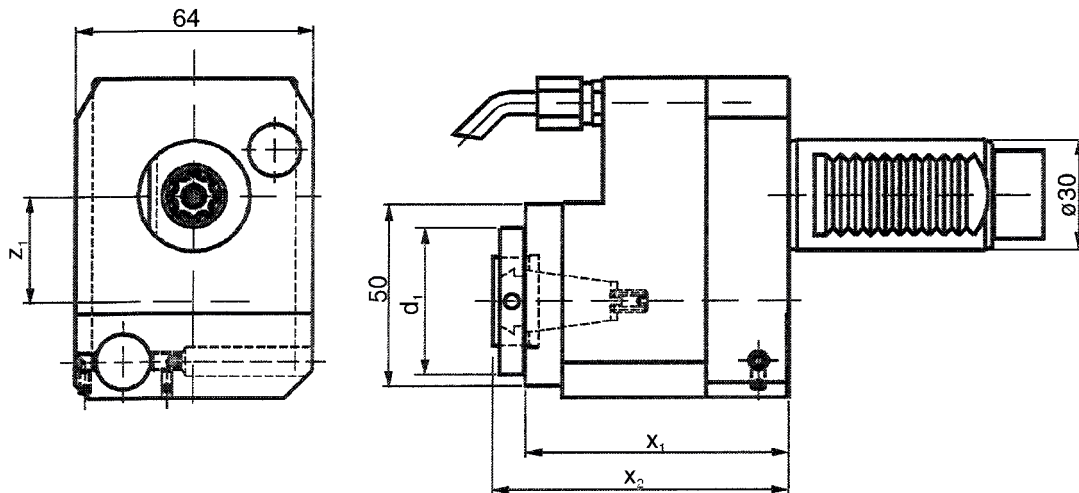

Innere Kühlmittelzufuhr; Zusatz IK an Bestellnummer anfügen
Central cooling supply; Please add IK behind order no.

Weldon/Whistle Notch auf Anfrage.
Weldon/Whistle Notch on request.
Weldon/Whistle Notch sur demande.

Bestell Nr Order No.	x ₁	x ₂	d ₁	i	z ₁	T _{max} [Nm]	Schlüsselsatz Wrench-set	Spannzange (siehe 1.27) Collet (see 1.27)
50.3016 LT10 R/1	71	80	40	1:2	28,8	8	LS 16/HS40	RD/ER 16 426E (1-10)
50.3025 LT10 R/2	85	97	48	2:1	33,75	40	LS 25/HS48	RD/ER 25 430E / *ET1-25 (2-16)

Axial Bohr- und Fräskopf

Axial drilling and milling head

Tête de perçage et fraisage

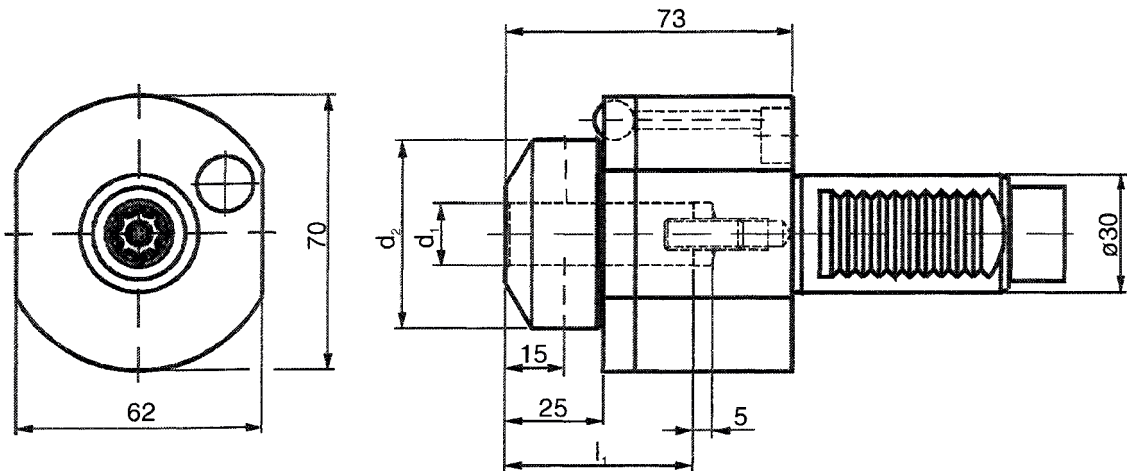

Innere Kühlmittelzufuhr; Zusatz IK an Bestellnummer anfügen
 Central cooling supply; Please add IK behind order no.

Bestell Nr Order No.	l_1	d_1	d_2	i	n_{max} [1/min]	T_{max} [Nm]	d_1
40.3008WN LT10	32	8	42	1:1	6000	25	8
40.3010WN LT10	39	10	42	1:1	6000	25	10
40.3012WN LT10	44	12	42	1:1	6000	25	12
40.3014WN LT10	45	14	42	1:1	6000	25	14
40.3016WN LT10	47	16	48	1:1	6000	25	16

Axial Fräskopf

Axial milling head

Tête de fraisage axial

Bestell Nr Order No.	i	n_{max} [1/min]	T_{max} [Nm]
42.3000 LT10	1:1	6000	25

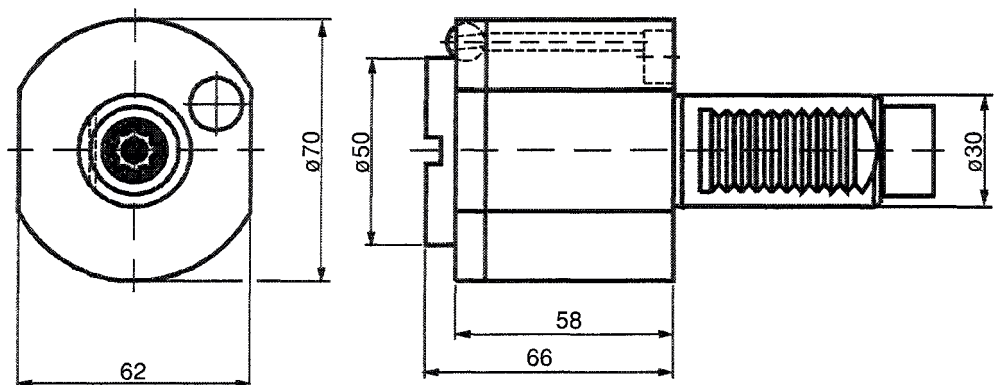

Bestell Nr Order No.	d	x
501.0507	13	24
501.0510	16	29
501.0520	22	31
501.0530	27	33

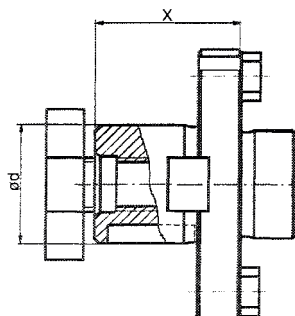

Radial Bohr- und Fräskopf

Radial drilling and milling head

Tête de perçage et fraisage radial

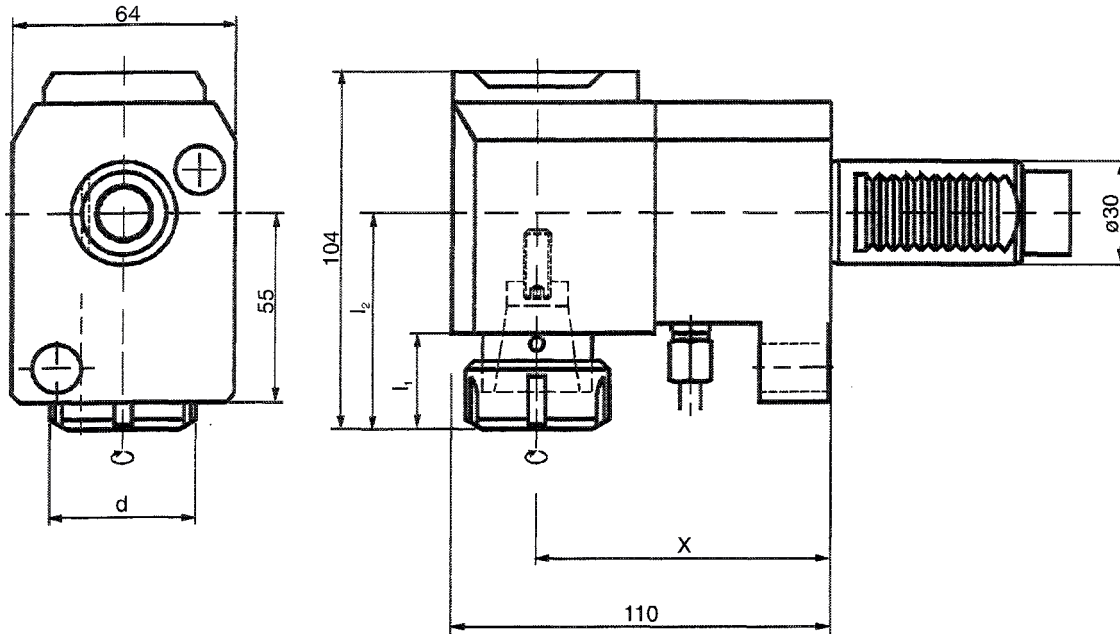

Ausführung R
wie gezeichnet
right hand design as shown
à droite suivant croquis

Ausführung L
spiegelbildlich
left hand design reversed
à gauche inversé

Doppelspindel auf Anfrage.
Double spindle on request.

Innere Kühlmittelzufuhr; Zusatz IK an Bestellnummer anfügen
Central cooling supply; Please add IK behind order no.

Bestell Nr Order No.	i	X	n_{max} [1/min]	L_1	L_2	T_{max} [Nm]	d	Schlüsselsatz Wrench-set	Spannzange (siehe 1.27) Collet (see 1.27)
60.3025 LT10 R	1:1	85	6000	28	63	25	42	225/HS40	RD/ER 25 430E (2-16) / *ET1-25
60.3025 LT10 L	1:1	85	6000	28	63	25	42	225/HS40	RD/ER 25 430E (2-16) / *ET1-25
60.3025 LT10 R/2	2:1	85	6000	28	63	25	42	225/HS40	RD/ER 25 430E (2-16) / *ET1-25
60.3025 LT10 L/2	2:1	85	4000	28	63	25	42	225/HS40	RD/ER 25 430E (2-16) / *ET1-25
60.3020 LT10 R/1	1:2	85	12000	27	62	16	35	GS30/HS40	RD/ER 20 428E (2-13) / *ET1-20
60.3020 LT10 L/1	1:2	85	12000	27	62	16	35	GS30/HS40	RD/ER 20 428E (2-13) / *ET1-20
60.3016 LT10 R/13	1:3	85	18000	25	75	6	32	216/HS32	RD/ER 16 426E (1-10)
60.3016 LT10 R/15	1:5							Maße auf Anfrage. / Dimensions on request.	
60.3025L LT10 R	1:1	95	6000	28	63	25	42	225/HS40	RD/ER 25 430E (2-16) / *ET1-25
60.3025L LT10 L	1:1	95	6000	28	63	25	42	225/HS40	RD/ER 25 430E (2-16) / *ET1-25

Radial Bohr- und Fräskopf

Radial drilling and milling head

Tête de perçage et fraisage radial

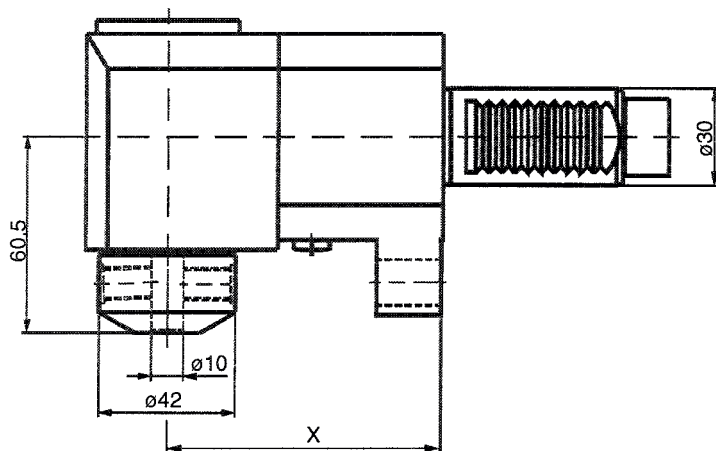
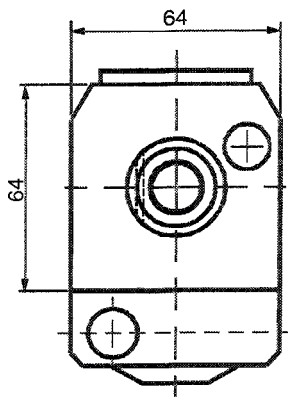

Bestell Nr Order No.	i	X	n_{max} [1/min]	T_{max} [Nm]
60.3016WN LT10 R	1:1	85	6000	25
60.3016WN LT10 L	1:1	85	6000	25
60.3016WN LT10 R/2	2:1	85	4000	32
60.3016WN LT10 L/2	2:1	85	4000	32
60.3016WNL LT10 R	1:1	95	6000	25
60.3016WNL LT10 L	1:1	95	6000	25
60.3016WNL LT10 R/2	2:1	95	4000	32
60.3016WNL LT10 L/2	2:1	95	4000	32

Ausführung R
wie gezeichnet
right hand design as shown
à droite suivant croquis

Ausführung L
spiegelbildlich
left hand design reversed
à gauche inversé

Innere Kühlmittelzufuhr; Zusatz IK an Bestellnummer anfügen
Central cooling supply; Please add IK behind order no.

Radial Fräskopf

Radial milling head

Tête de fraisage radial

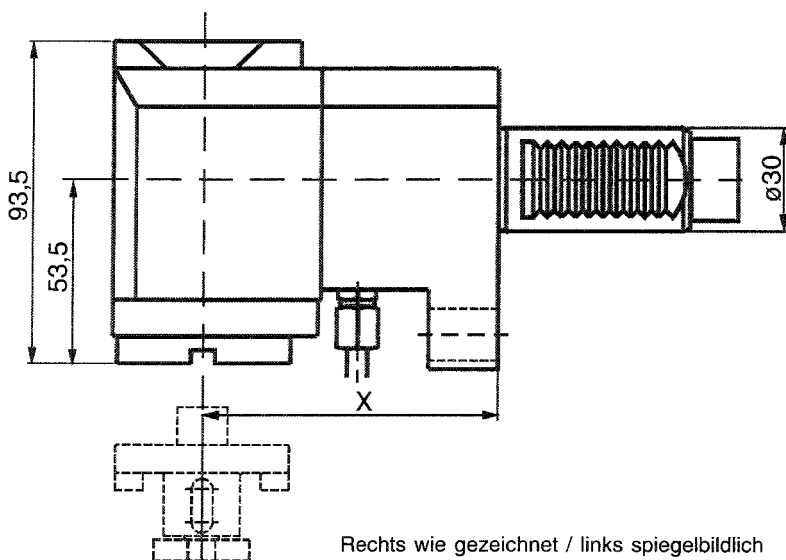
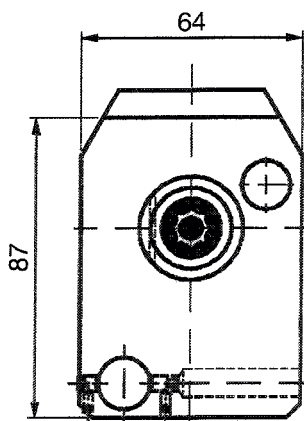

Einsätze siehe Seite 6.35.2.
Inserts see page 6.35.2.

Rechts wie gezeichnet / links spiegelbildlich
Right hand as shown / left hand reversed

Bestell Nr Order No.	i	X	n_{max} [1/min]	T_{max} [Nm]
62.3000 LT10 R	1:1	85	6000	25
62.3000 LT10 L	1:1	85	6000	25
62.3000 LT10 R/2	2:1	85	4000	32
62.3000 LT10 L/2	2:1	85	4000	32

Bestell Nr Order No.	i	X	n_{max} [1/min]	T_{max} [Nm]
62.3000L LT10 R	1:1	95	6000	25
62.3000L LT10 L	1:1	95	6000	25
62.3000L LT10 R/2	2:1	95	4000	32
62.3000L LT10 L/2	2:1	95	4000	32

Schwenkkopf ±105°

Swivel level ±105°

Tête pivotante ±105°

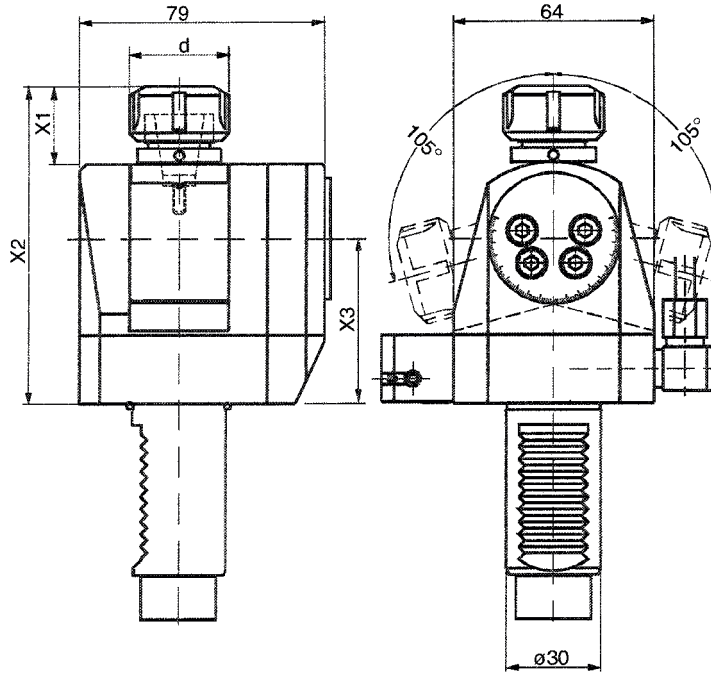

Bestell Nr Order No.	i	X ₁	X ₂	X ₃	d	n _{max} [1/min]	T _{max} [Nm]	Spannzangen siehe Seite 1.27
63.3016 LT10/1	1:2	25	102	53	32	12000	8	RD/ER 16 426E (1-10)
63.3016L LT10/1	1:2	25	134	85	32	12000	8	RD/ER 16 426E (1-10)
63.3020 LT10	1:1	26	117	60	35	6000	16	RD/ER 20 428E (2-13)
63.3020L LT10	1:1	26	142	85	35	6000	16	RD/ER 20 428E (2-13)

Scheibenfräskopf

milling adaptor

Tête de fraisage radial

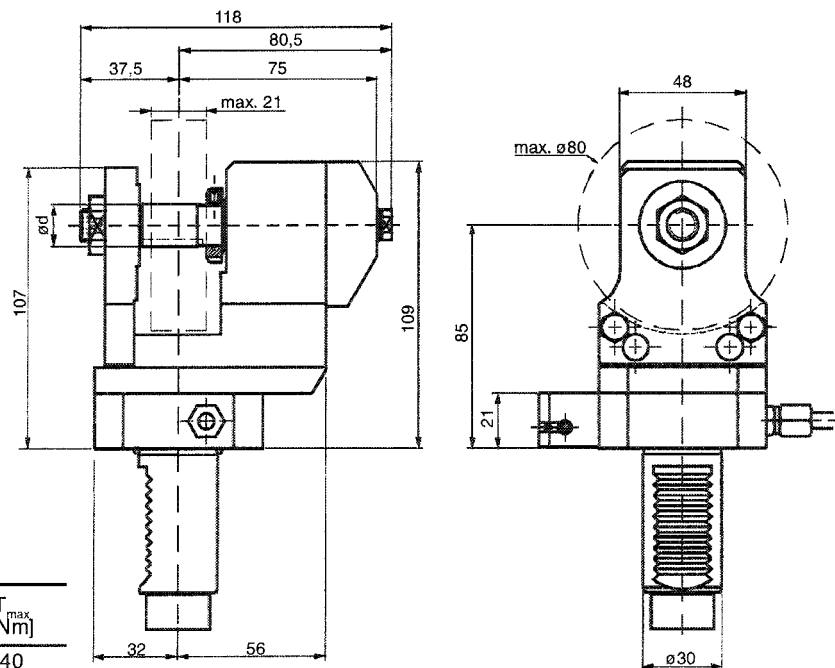

Fräswelle austauschbar.
Milling spindle changeable.

Bestell Nr Order No.	i	Fräswelle ød	n _{max} [1/min]	T _{max} [Nm]
64.3016 LT10	3:1	16	2000	40
64.3022 LT10	3:1	22	2000	40



**Statische- und angetriebene Werkzeuge für
Okuma LT15/LT300 Maschinen**

Static and driven tools for Okuma LT15/LT300 machines

Porte-outils statiques et motorisés pour machines

Okuma LT15/LT300

Doppel-Drehhalter

Für Haupt- und Gegenspindel

Turning tool holder

For main an subspindle

Porte-outil

Pour broche et contre broche

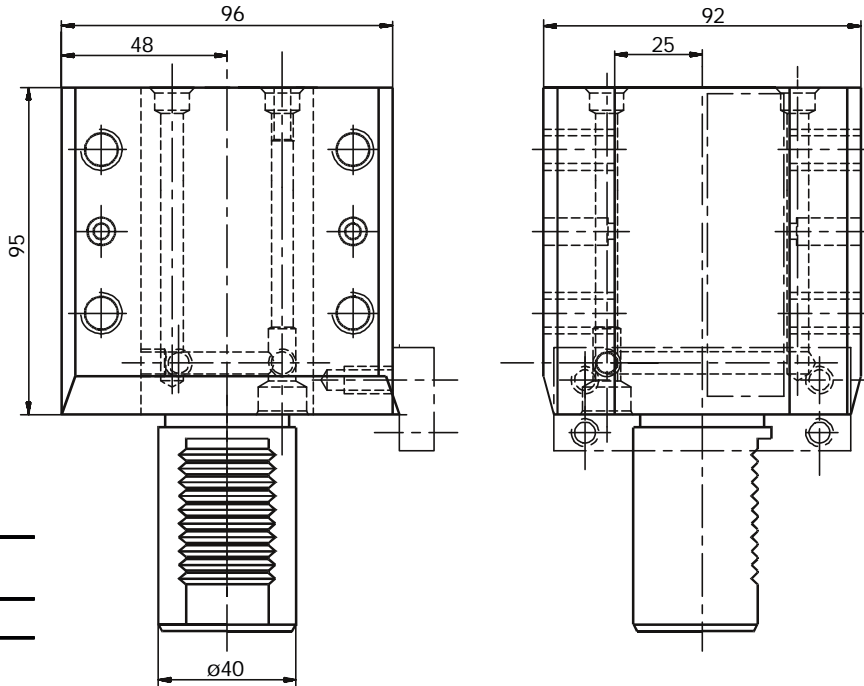

Bestell Nr
Order No.
15.4025 LT15

Spannzangenhalter

Collet chuck

Porte pince

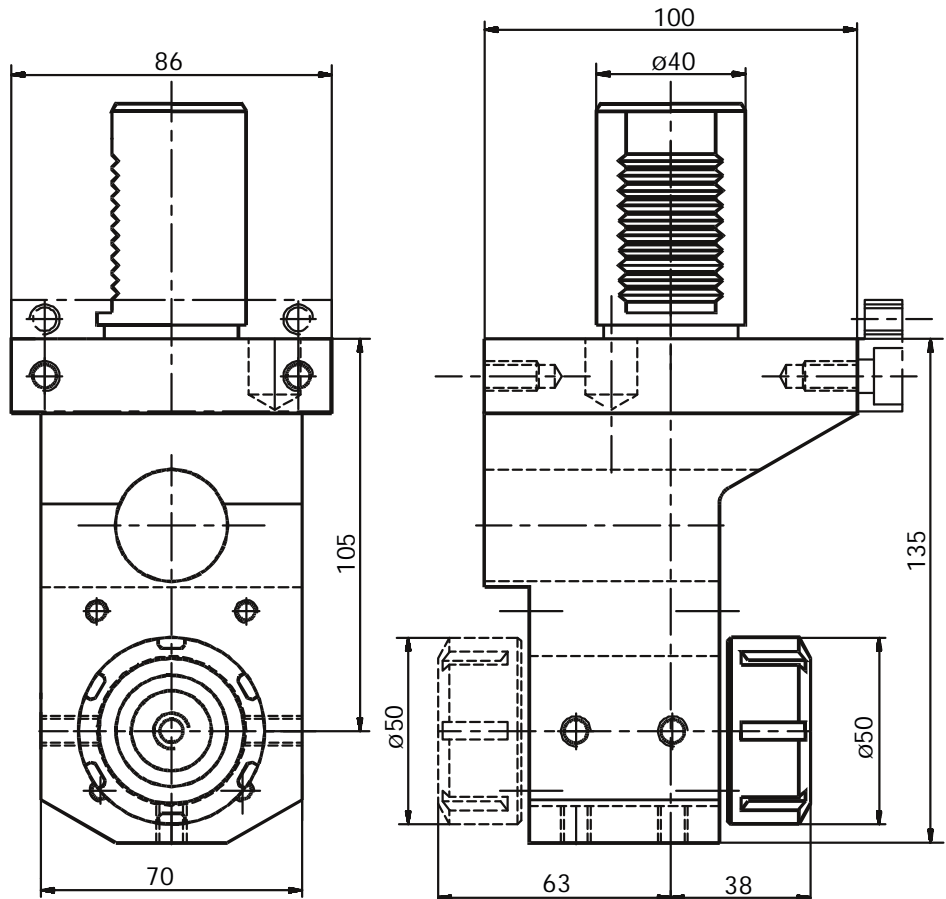

Spannzange / Collet
RD/ER 32 470E (3-20)
zum Gewindeschneiden / for tapping
ET 1-32

Bestell Nr
Order No.

- 31.4032 LT15R Bearbeitung zur Gegenspindel For subspindle
- 31.4032 LT15L Bearbeitung zur Hauptspindel For main spindle
- 31.4032 DLT15 Bearbeitung Haupt- und Gegenspindel For main and sub-spindle

Bohrstangenhalter

Boring bar holder

Porte barre d'alesage

Bestell Nr Order No.	d
19.4032 LT15 R	32
19.4032 LT15 L	32
19.4040 LT15 R	40
19.4040 LT15 L	40

R wie gezeichnet / as shown
L spiegelbildlich / reversed

Weitere \varnothing auf Anfrage
Other \varnothing on request
Autres \varnothing sur demande

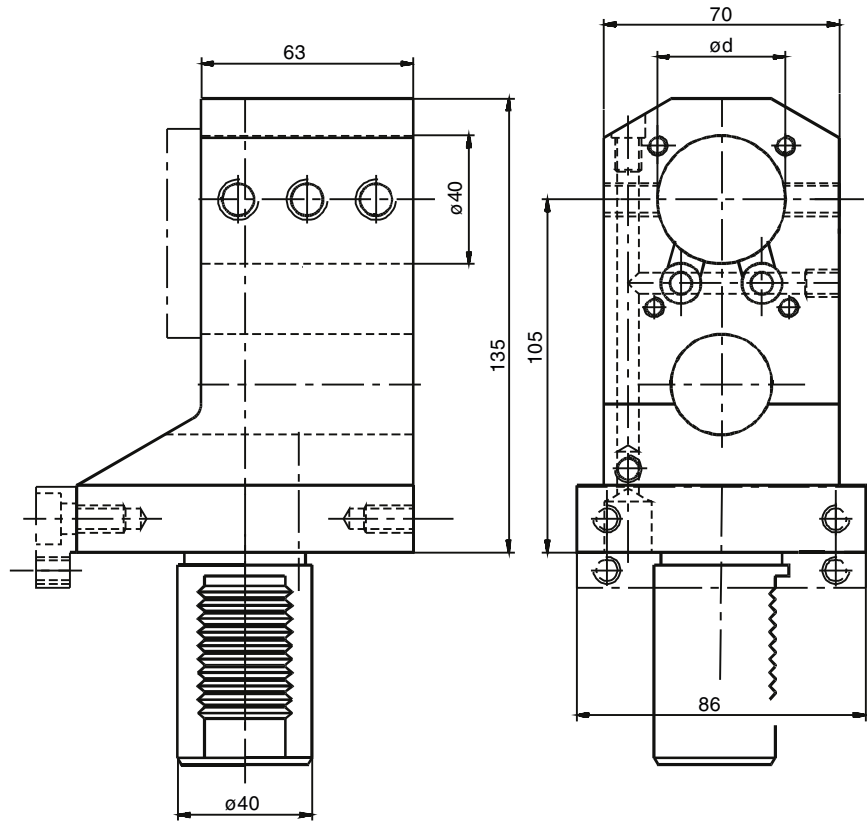

Kombihalter und Aufnahmehülsen

Für Haupt- und Gegenspindel

Combiholder and adaptor sleeve

For main and subspindle

Porte-outil combiné et douille de reduction

Pour broche and contre broche

Bestell Nr Order No.	d
17.4032 LT15	32
17.4040 LT15	40

Weitere \varnothing auf Anfrage
Other \varnothing on request
Autres \varnothing sur demande

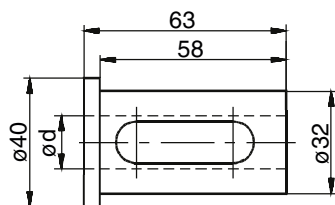

Bestell Nr Order No.	d
28.3206 G200	06
28.3208 G200	08
28.3210 G200	10
28.3212 G200	12
28.3216 G200	16
28.3220 G200	20
28.3225 G200	25
28.3225.4 G200	25,4 (1")

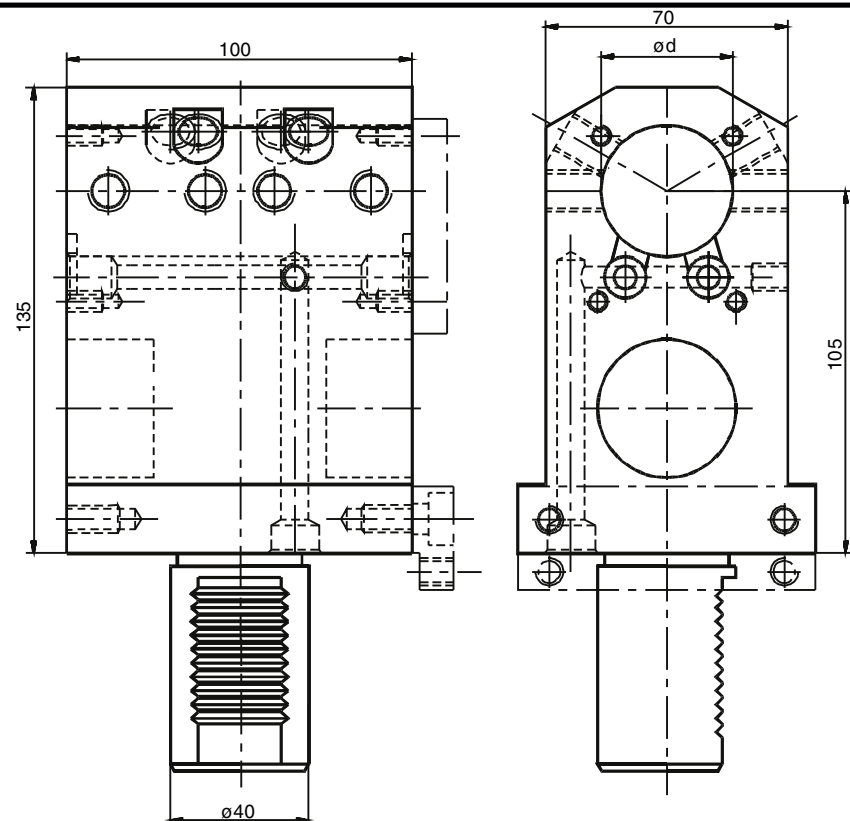

Abstechhalter

Infeed toolholder

Support de plongé

Wechselhalter 32.412 SH 32
siehe Seite 1.11

Adaptor 32.412 SH 32
see page 1.11

Bestell Nr
Order No.

32.4032 LT15

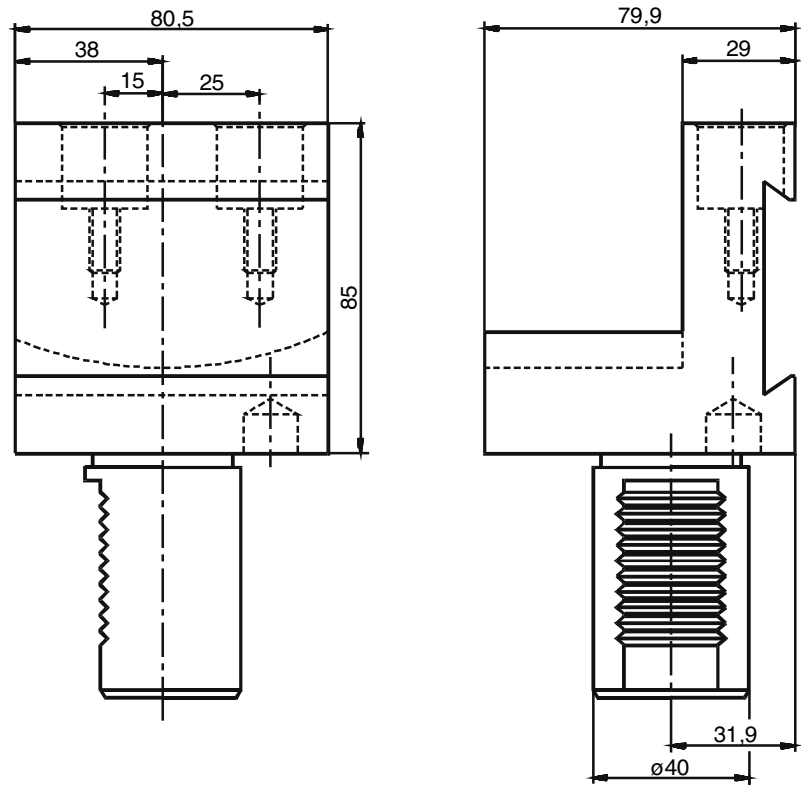

Vierkant
Queraufnahme

Turning tool
radial

Radial-Porte-outil
carré

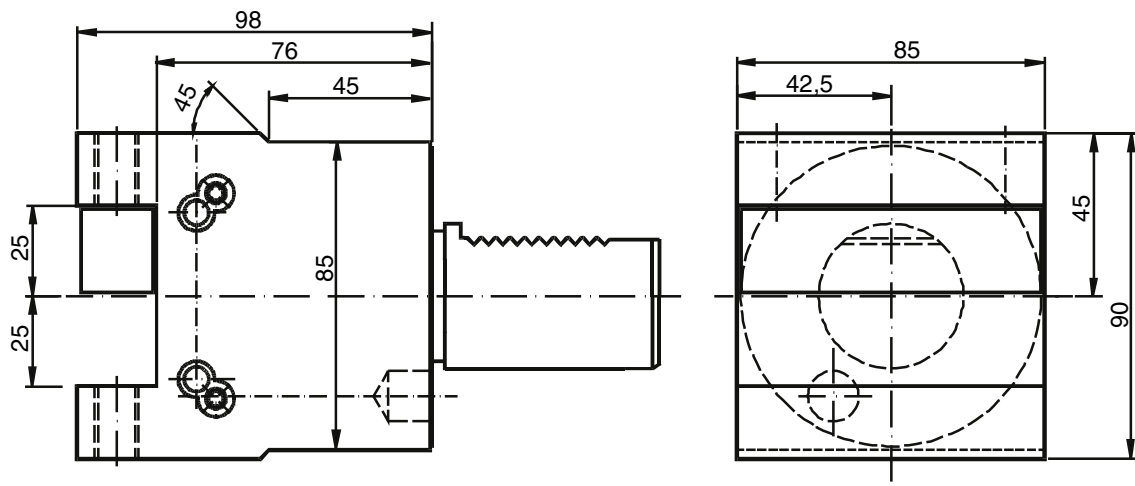

Bestell Nr
Order No.

5.4025 G300	wie gezeichnet as shown suivant croquis
6.4025 G300	spiegelbildlich reversed inversé
5.4025 G300 RL	mit doppelverzahntem DIN-Schaft with doubletoothed DIN shaft universelle pour broche et contre-broche

Axial Bohr- und Fräskopf

Axial drilling and milling head

Tête de perçage et fraisage

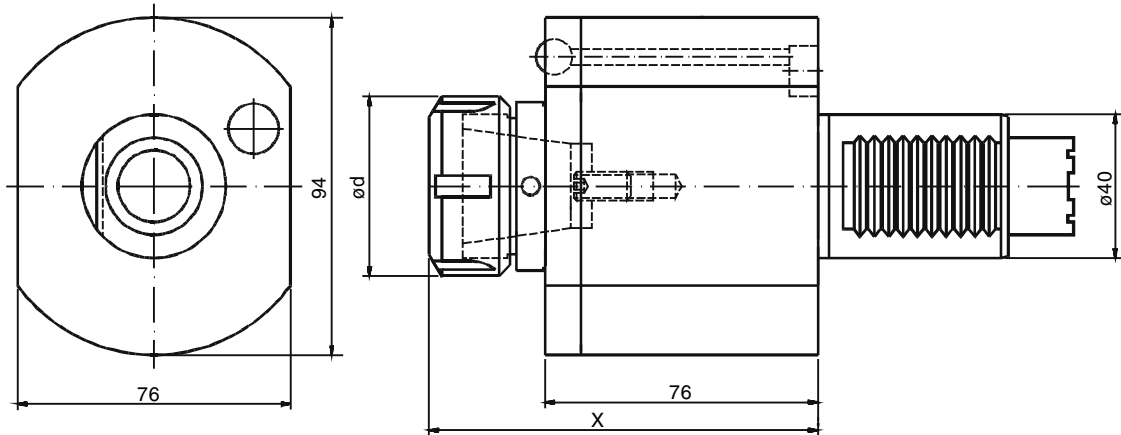

Innere Kühlmittelzufuhr; Zusatz IK an Bestellnummer anfügen
Central cooling supply; Please add IK behind order no.

Bestell Nr Order No.	i	X	d	n_{max} [1/min]	T_{max} [Nm]	Schlüsselsatz Wrench-set	Spannzange (siehe 1.27) Collet (see 1.27)
40.4025 LT15	1:1	80	42	5000	25	225/HS45	RD/ER 25 430E (2-16)
40.4032 LT15	1:1	82	50	5000	50	232/HS45	RD/ER 32 470E (3-20)

Axial Bohr- und Fräskopf

Axial drilling and milling head

Tête de perçage et fraisage

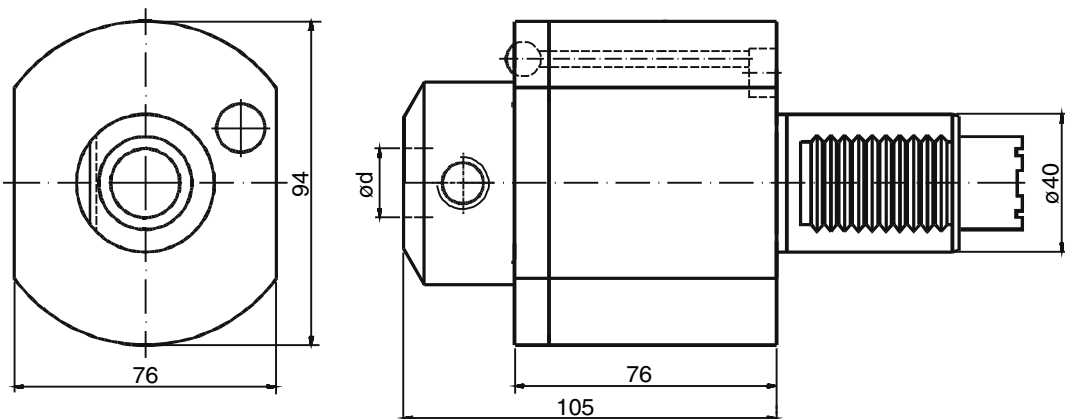

Innere Kühlmittelzufuhr; Zusatz IK an Bestellnummer anfügen
Central cooling supply; Please add IK behind order no.

Bestell Nr Order No.	i	d	n_{max} [1/min]	T_{max} [Nm]
40.4016 WN LT15	1:1	16	5000	25
40.4020 WN LT15	1:1	20	5000	50

Radial Bohr- und Fräskopf

Radial drilling and milling head

Tête de perçage et fraisage radial

Innere Kühlmittelzufuhr;
Zusatz IK an Bestellnummer anfügen
Central cooling supply;
Please add IK behind order no.

- R wie gezeichnet / as shown
- L spiegelbildlich / reversed
- RL mit doppelverzahntem DIN-Schaft (Patent Traub) with doubletoothed DIN shaft (Patent Traub)

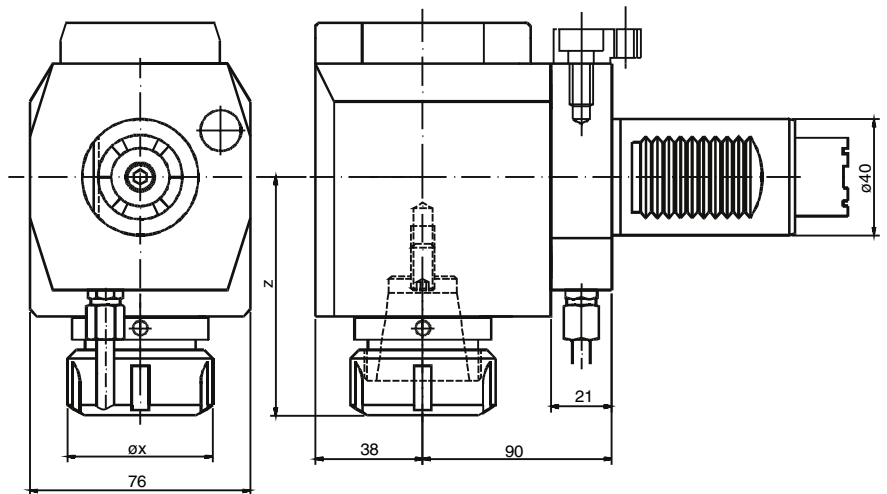

Bestell Nr Order No.	Z	i	d	n_{max} [1/min]	T_{max} [Nm]	Schlüsselsatz Wrench-set	Spannzange (siehe 1.27) Collet (see 1.27)
60.4020 LT15/L	62	1:2	35	10000	10	GS20/HS40	RD/ER 20 4285R (2-13)
60.4020 LT15/1R	62	1:2	35	10000	10	GS20/HS40	RD/ER 20 4285R (2-13)
60.4020 LT15/1RL	62	1:2	35	10000	10	GS20/HS40	RD/ER 20 4285R (2-13)
60.4025 LT15/L	77	1:1	42	5000	25	225/HS45	RD/ER 25 430E (2-16)
60.4025 LT15/R	77	1:1	42	5000	25	225/HS45	RD/ER 25 430E (2-16)
60.4025 LT15/RL	77	1:1	42	5000	25	225/HS45	RD/ER 25 430E (2-16)
60.4032 LT15/L	82	1:1	50	5000	50	232/HS45	RD/ER 32 470E (3-20)
60.4032 LT15/R	82	1:1	50	5000	50	232/HS45	RD/ER 32 470E (3-20)
60.4032 LT15/RL	82	1:1	50	5000	50	232/HS45	RD/ER 32 470E (3-20)
60.4032 LT15L/2	82	2:1	50	3000	80	232/HS45	RD/ER 32 470E (3-20)
60.4032 LT15R/2	82	2:1	50	3000	80	232/HS45	RD/ER 32 470E (3-20)
60.4032 LT15RL/2	82	2:1	50	3000	80	232/HS45	RD/ER 32 470E (3-20)

Radial Bohr- und Fräskopf

Radial drilling and milling head

Tête de perçage et fraisage radial

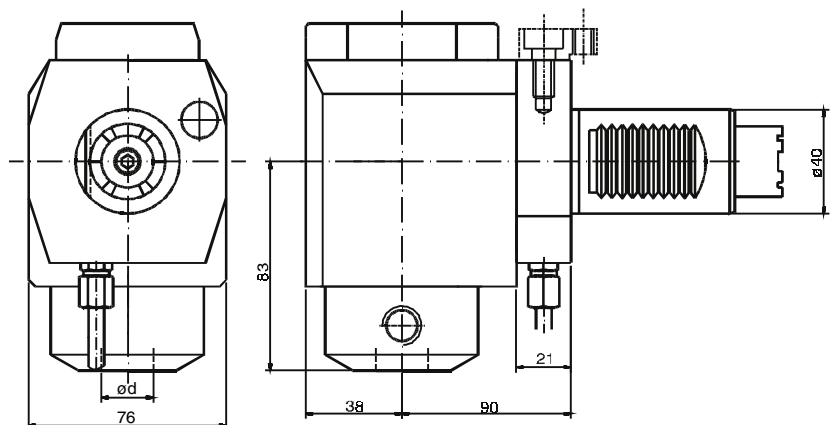

Bestell Nr Order No.	i	d	n_{max} [1/min]	T_{max} [Nm]
60.4016 WN LT15 L	1:1	16	5000	25
60.4016 WN LT15 R	1:1	16	5000	25
60.4016 WN LT15 RL	1:1	16	5000	25
60.4020 WN LT15 L	1:1	20	5000	50
60.4020 WN LT15 R	1:1	20	5000	50
60.4020 WN LT15 RL	1:1	20	5000	50
60.4020 WN LT15 L/2	2:1	20	3000	80
60.4020 WN LT15 R/2	2:1	20	3000	80
60.4020 WN LT15 RL/2	2:1	20	3000	80

Innere Kühlmittelzufuhr; Zusatz IK an Bestellnummer anfügen
Central cooling supply; Please add IK behind order no.

- R wie gezeichnet / as shown
- L spiegelbildlich / reversed
- RL mit doppelverzahntem DIN-Schaft (Patent Traub) with doubletoothed DIN shaft (Patent Traub)



**Statische- und angetriebene Werkzeuge für Okuma
LB2000 / LB3000 Maschinen**

Static and driven tools for Okuma LB2000 / LB3000 machines

Porte-outils statiques et motorisés pour machines

Okuma LB2000 / LB3000

Außendrehhalter

OD-holder

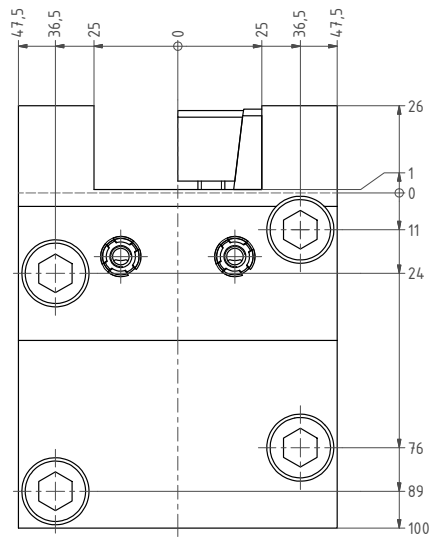
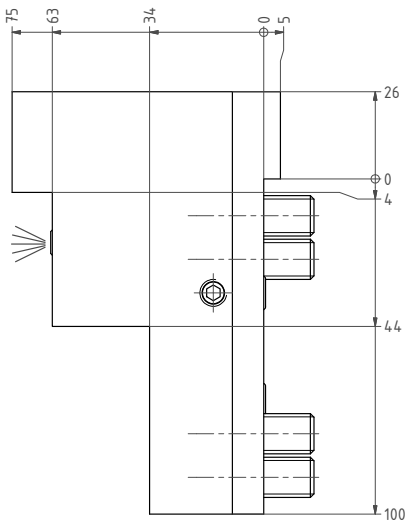

Nr./No.
4.BMT25LB2000

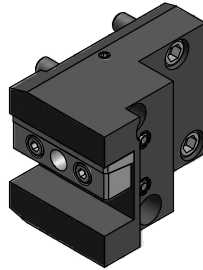

Doppel-Außendrehhalter

Double OD-holder

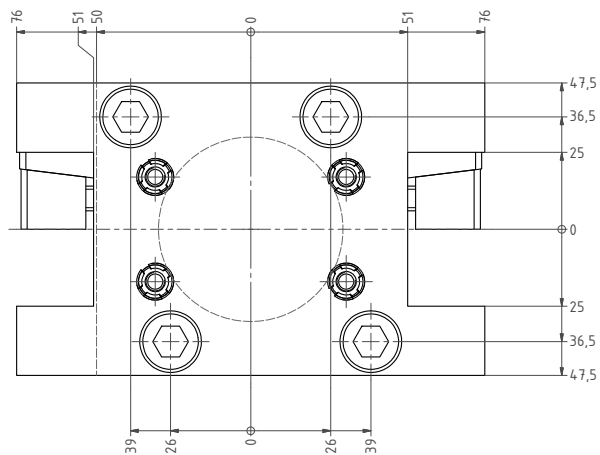
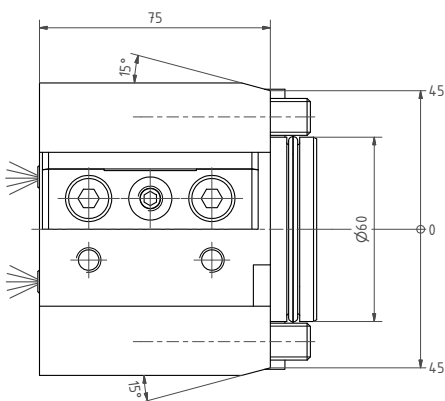

Nr./No.
15.BMT25LB2000

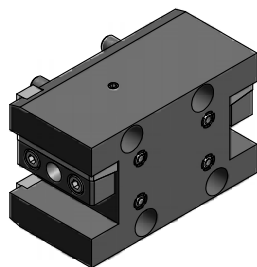

Plandrehhalter

Facing holder

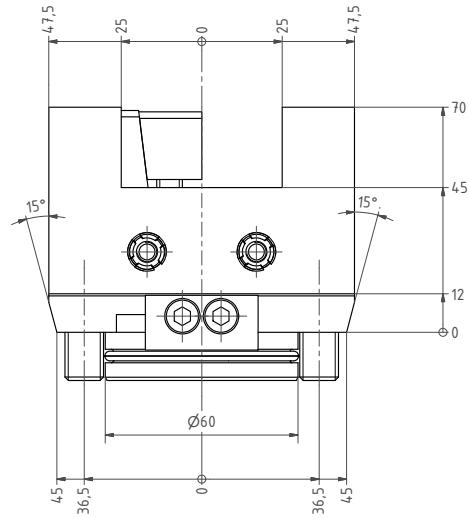
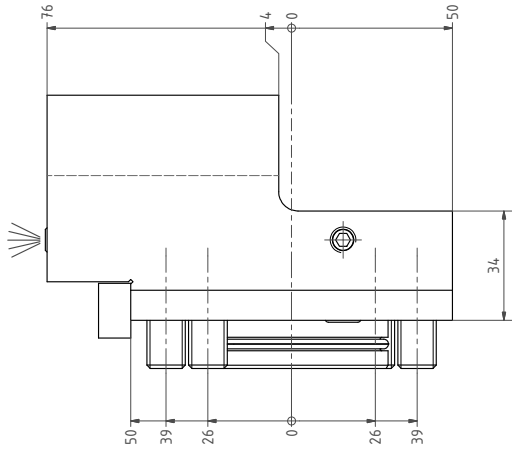

Nr./No.
8.BMT25LB2000

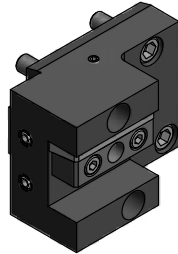

Kombihalter

Combi holder

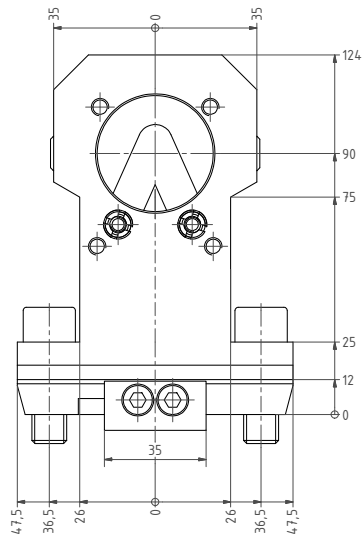
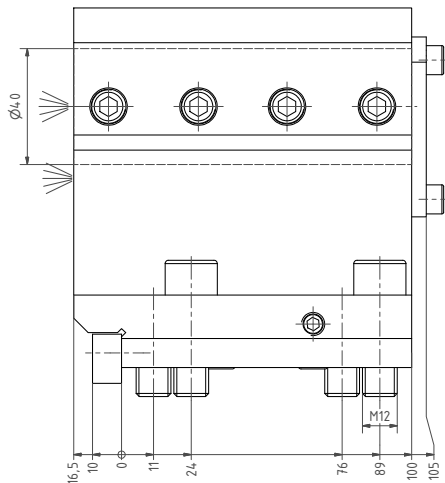

Nr./No.
17.BMT40LB2000

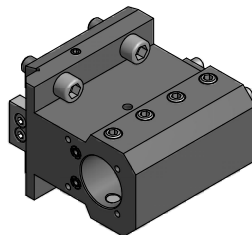

Reduzierhülsen / Reducing sleeves

28.4032S	$\varnothing 32$	28.4012S	$\varnothing 12$
28.4025S	$\varnothing 25$	28.4010S	$\varnothing 10$
28.4020S	$\varnothing 20$	28.4008S	$\varnothing 8$
28.4016S	$\varnothing 16$		

andere \varnothing auf Anfrage / other \varnothing on request

Axial Bohr- und Fräskopf

Axial drilling and milling head

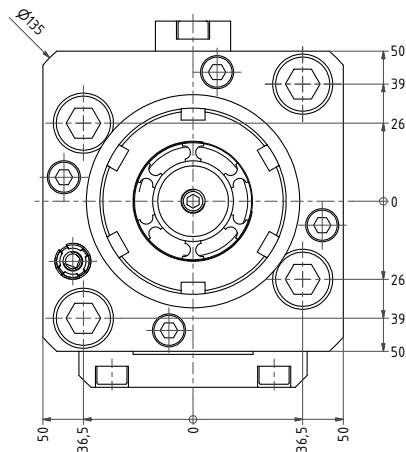
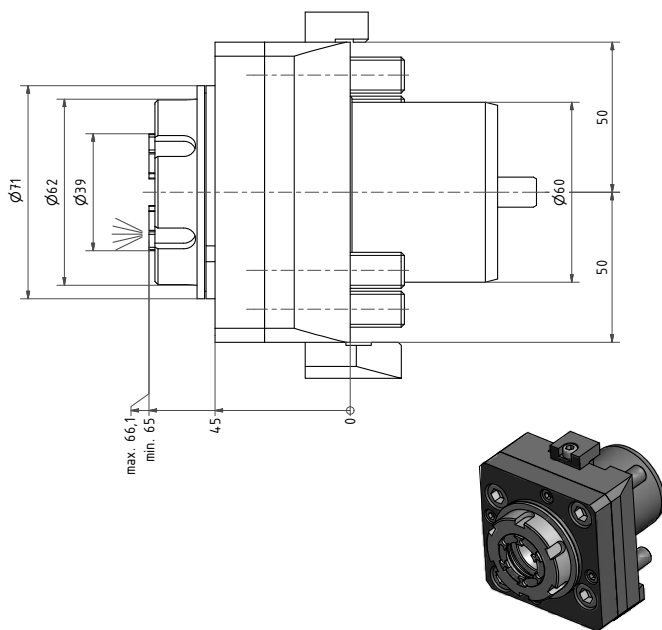

Nr. / No.	i	n _{max}	T _{max}
40.6032LB2000BMTIM	1:1	6000 1/min	50 Nm
40.6032LB2000BMTIKIM	1:1	6000 1/min	50 Nm

IK = Innenkühlung
IK = internal cooling

Axial Bohr- und Fräskopf

Axial drilling and milling head

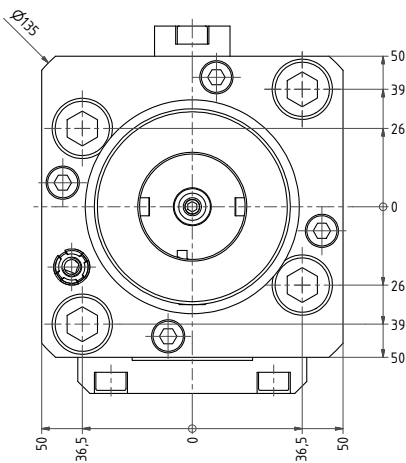
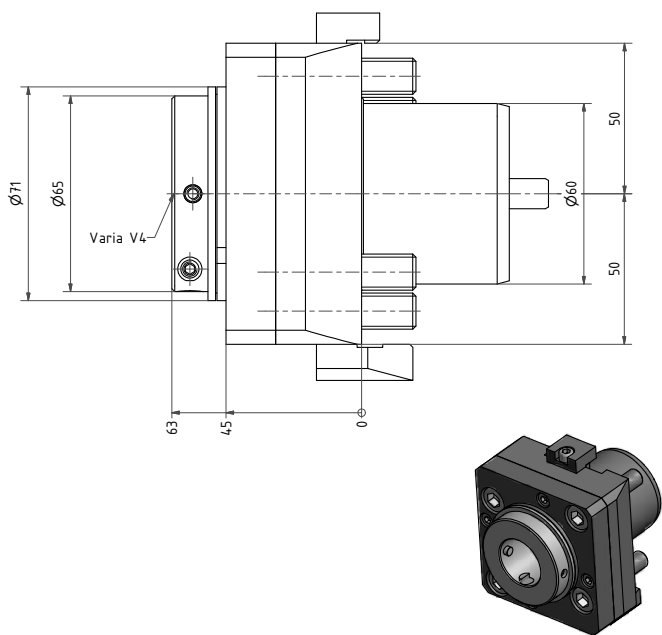

Nr. / No.	i	n _{max}	T _{max}
40.60V4LB2000BMT	1:1	6000 1/min	50 Nm
40.60V4LB2000BMTIK	1:1	6000 1/min	50 Nm

EWS-Varia

IK = Innenkühlung
IK = internal cooling

Axial Bohr- und Fräskopf

Axial drilling and milling head

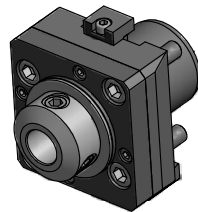
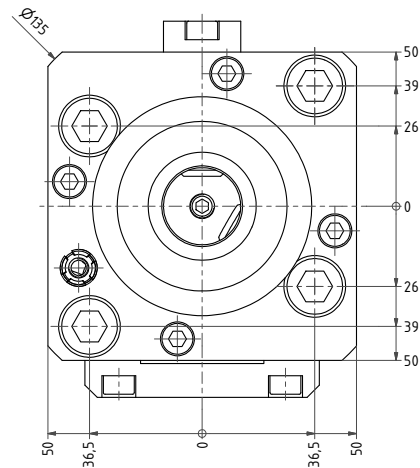
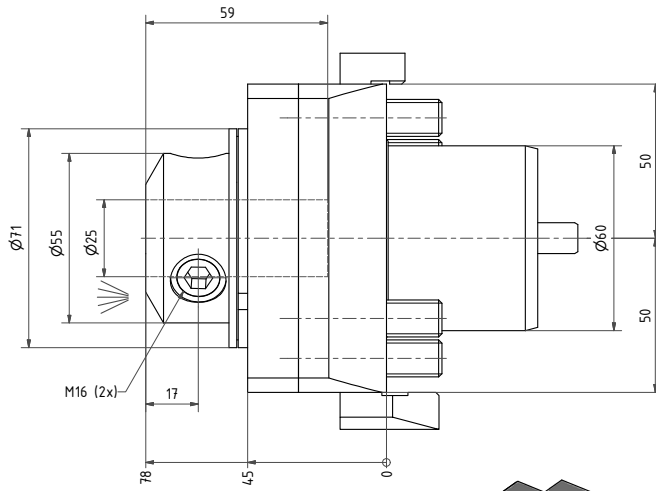

Weldon / Whistle Notch

Nr. / No.	i	n _{max}	T _{max}
40.6025WNLB2000BMT	1:1	6000 1/min	50 Nm
40.6025WNLB2000BMTIK	1:1	6000 1/min	50 Nm

IK = Innenkühlung
IK = internal cooling

andere \varnothing auf Anfrage / other \varnothing on request

Axial Fräskopf

Axial milling head

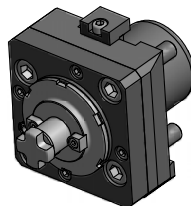
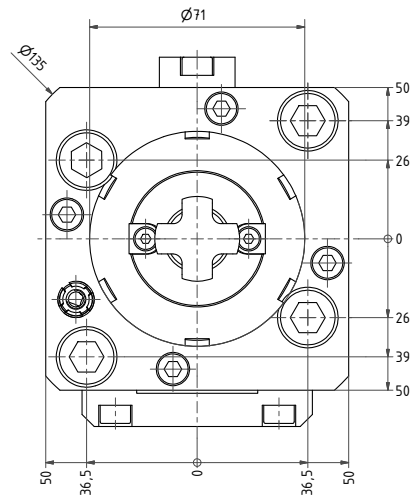
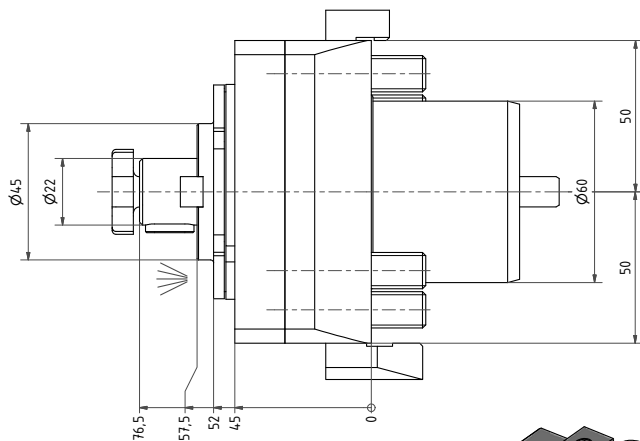

Nr. / No.	\varnothing	i	n _{max}	T _{max}
42.6022KRLB2000BMT	22	1:1	4000 1/min	50 Nm

andere \varnothing auf Anfrage / other \varnothing on request

Radial Bohr- und Fräzkopf

Radial drilling and milling head

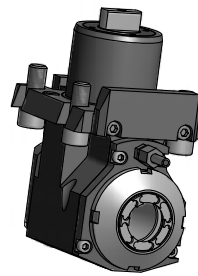
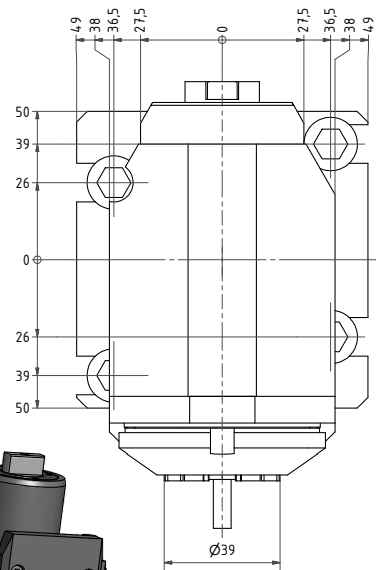
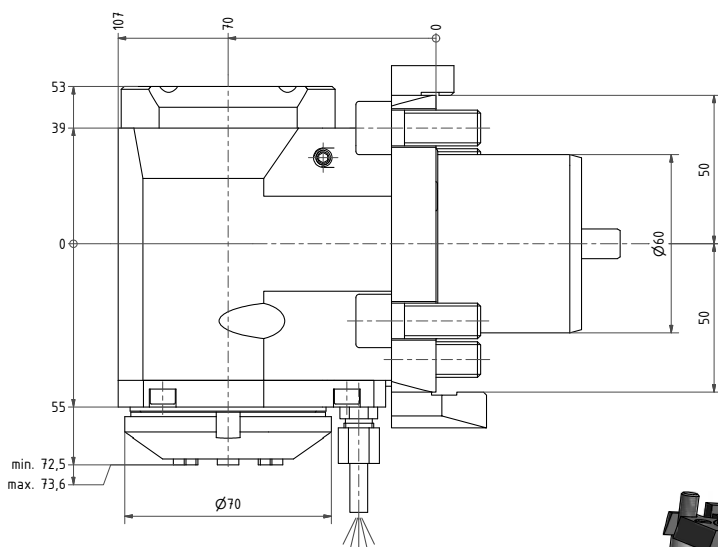

IK = Innenkühlung
IK = internal cooling

Nr. / No.	i	n _{max}	T _{max}
60.6032LB2000BMTIM	1:1	6000 1/min	50 Nm
60.6032LB2000BMTIKIM	1:1	6000 1/min	50 Nm

Radial Bohr- und Fräskopf

Radial drilling and milling head

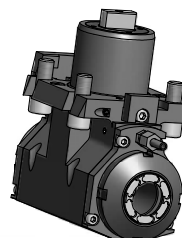
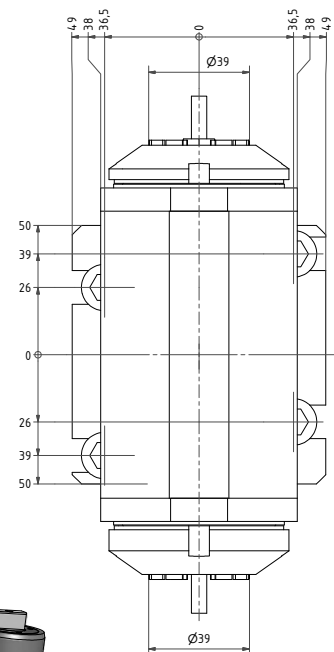
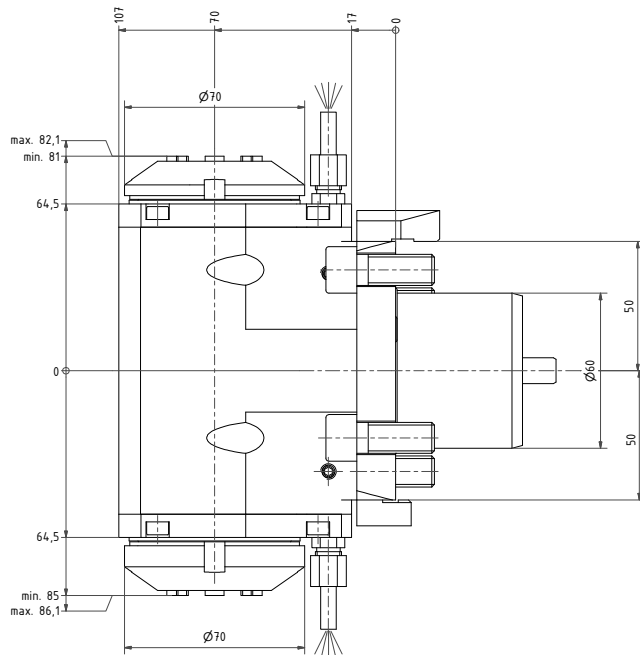

doppelseitig / double

Nr. / No.	i	n _{max}	T _{max}
60.6032DLB2000BMTIM	1:1	6000 1/min	50 Nm

Radial Bohr- und Fräskopf

Radial drilling and milling head

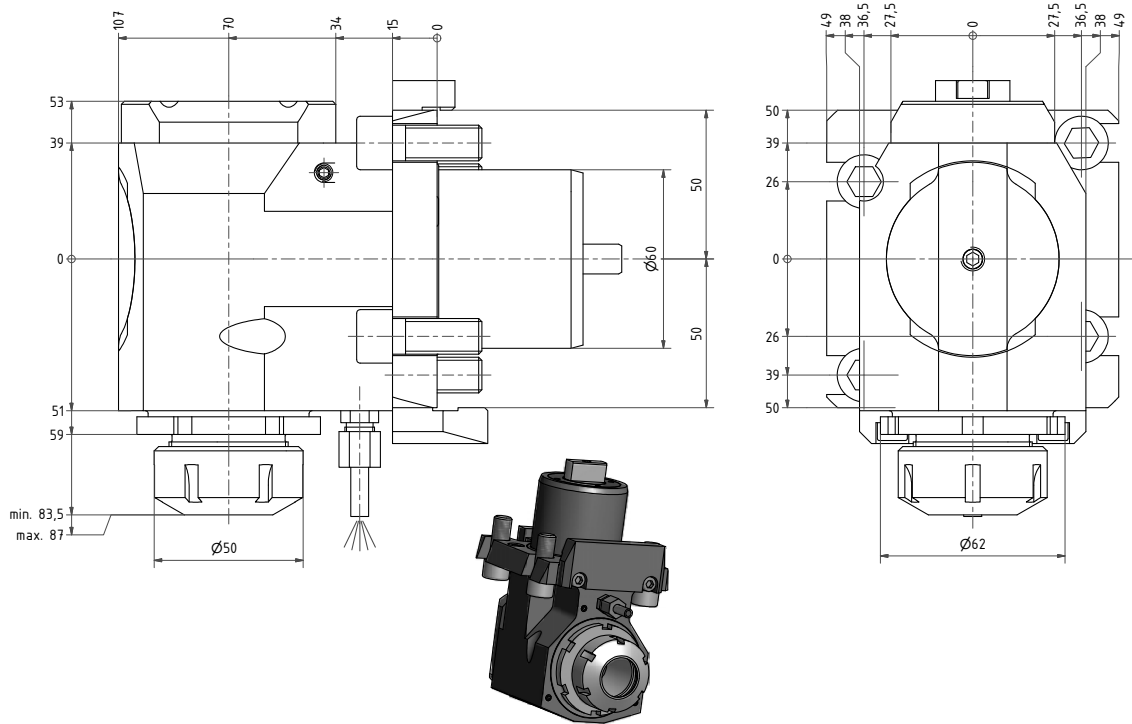

Nr. / No.	i	n _{max}	T _{max}
60.6032LB2000BMT11	1:2	10000 1/min	25 Nm
60.6032LB2000BMTIK11	1:2	10000 1/min	25 Nm

IK = Innenkühlung
IK = internal cooling

Radial Bohr- und Fräskopf

Radial drilling and milling head

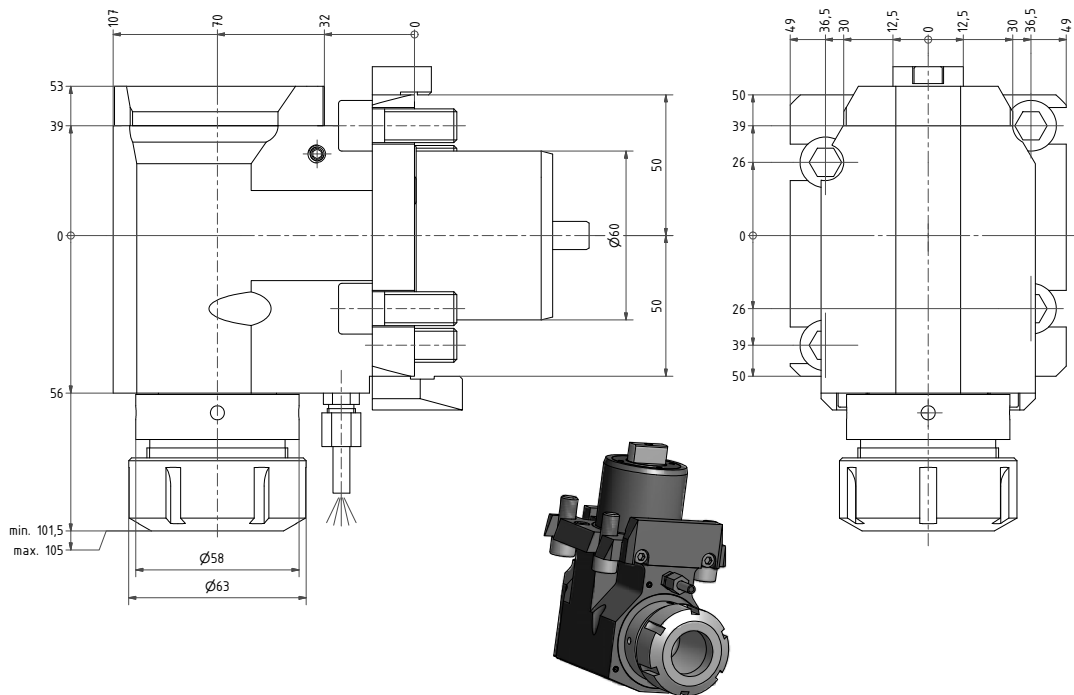

Nr. / No.	i	n _{max}	T _{max}
60.6040LB2000BMT12	2:1	3000 1/min	80 Nm
60.6040LB2000BMTIK12	2:1	3000 1/min	80 Nm

IK = Innenkühlung
IK = internal cooling

Radial Bohr- und Fräskopf Radial drilling and milling head

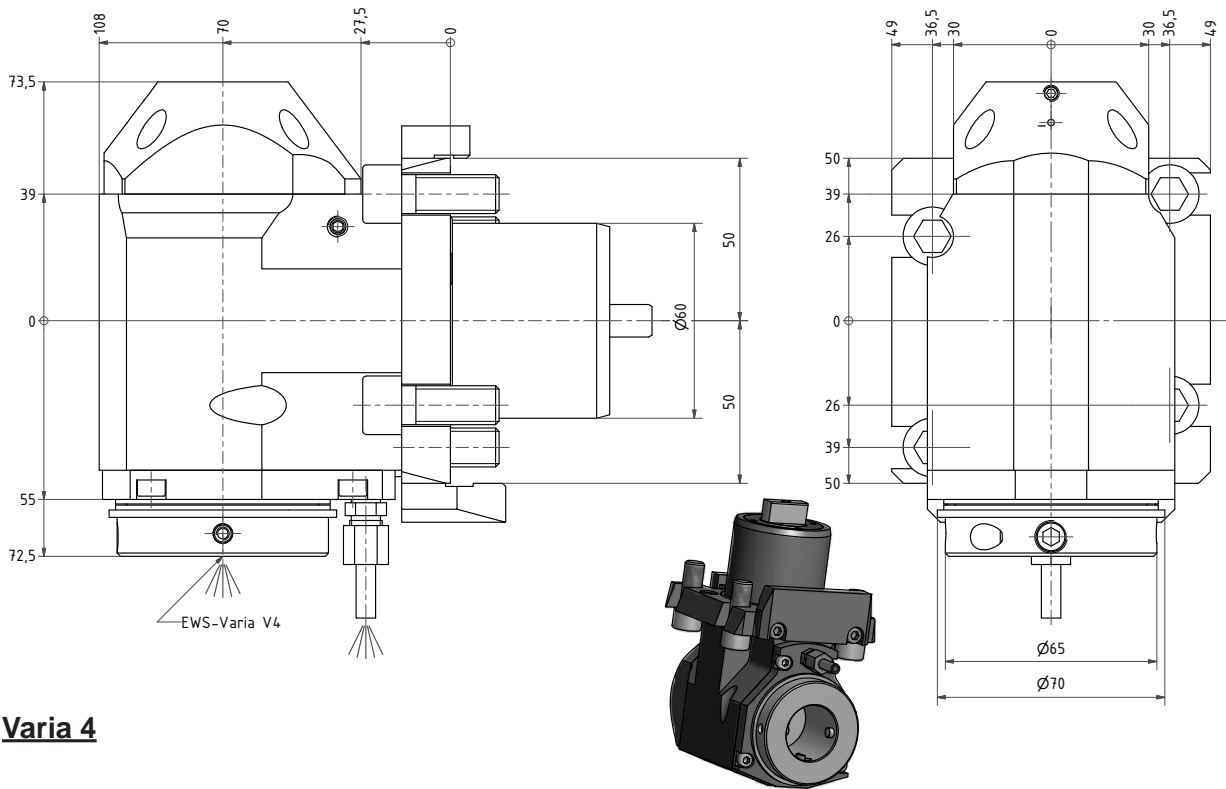

Varia 4

Nr. / No.	i=	n _{max}	T _{max}
60.60V4LB2000BMT	1:1	6000 1/min	50 Nm
60.60V4LB2000BMTIK	1:1	6000 1/min	50 Nm
60.60V4LB2000BMTI1	1:2	10000 1/min	25 Nm
60.60V4LB2000BMTIKI1	1:2	10000 1/min	25 Nm
60.60V4LB2000BMTI2	2:1	3000 1/min	80 Nm
60.60V4LB2000BMTIKI2	2:1	3000 1/min	80 Nm

IK = Innenkühlung
IK = internal cooling

Radial Bohr- und Fräskopf

Radial drilling and milling head

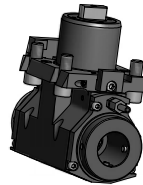
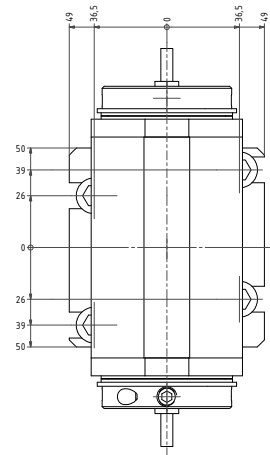
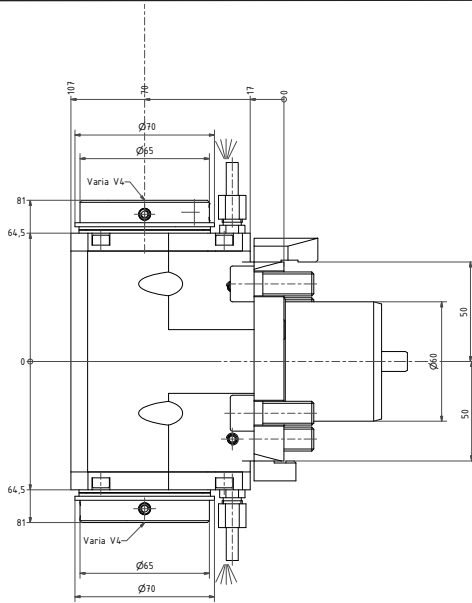

Varia 4
doppelseitig/ double

Nr. / No.	i	n _{max}	T _{max}
60.60V4DLB2000BMT	1:1	6000 1/min	50 Nm

Radial Bohr- und Fräskopf

Radial drilling and milling head

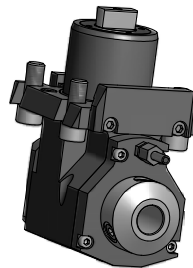
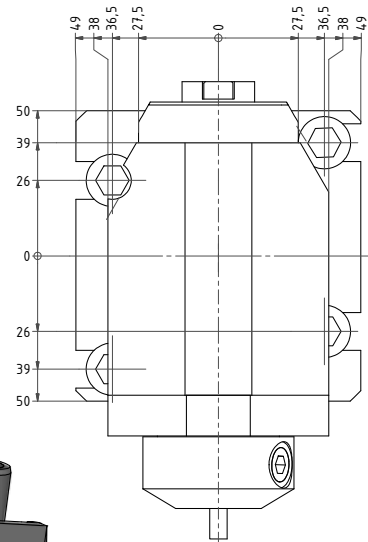
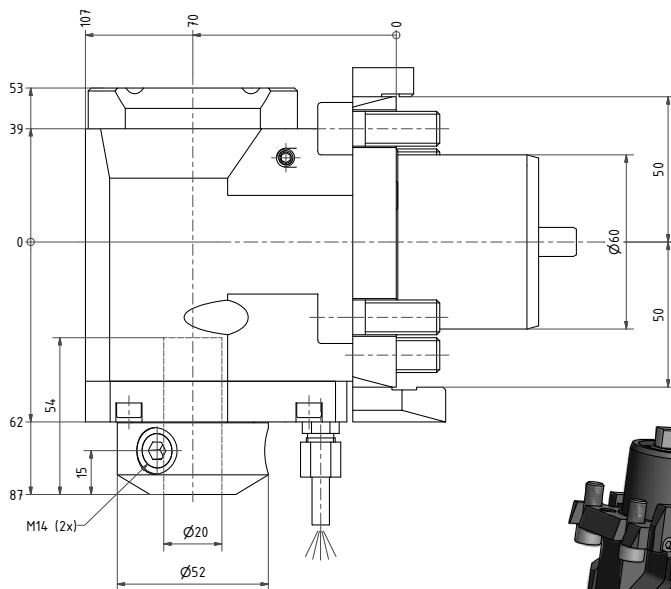

IK = Innenkühlung
IK = internal cooling

Nr. / No.	i	n _{max}	T _{max}
60.6020WNLB2000BMT	1:1	6000 1/min	50 Nm
60.6020WNLB2000BMTIK	1:1	6000 1/min	50 Nm

andere Ø auf Anfrage / other Ø on request
andere Übersetzungen auf Anfrage / other ratios on request

Radial Fräskopf

Radial milling head

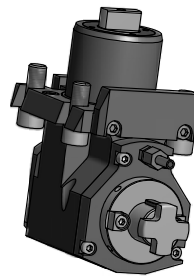
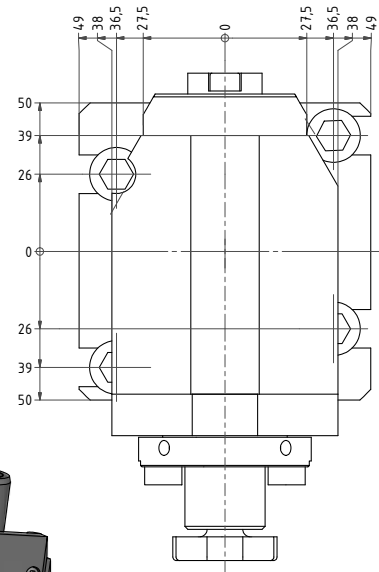
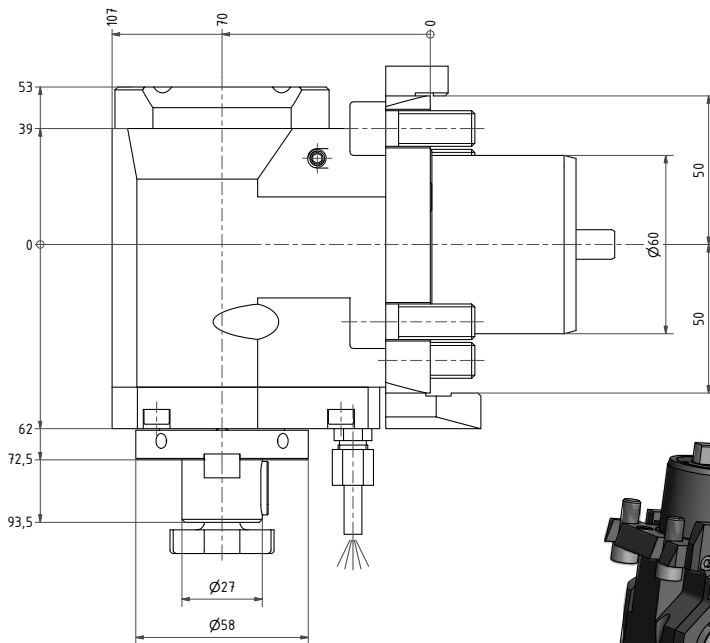

Nr. / No.	i	n _{max}	T _{max}
62.6027LB2000BMT	1:1	6000 1/min	50 Nm

Andere Fräsdorn Ø auf Anfrage /
Other milling arbor Ø on request

Schwenkkopf

Swivel head

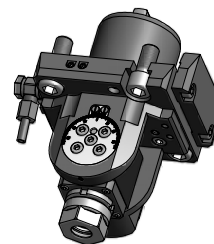
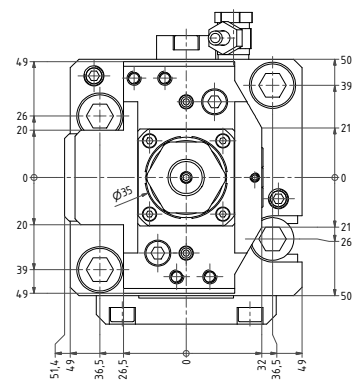
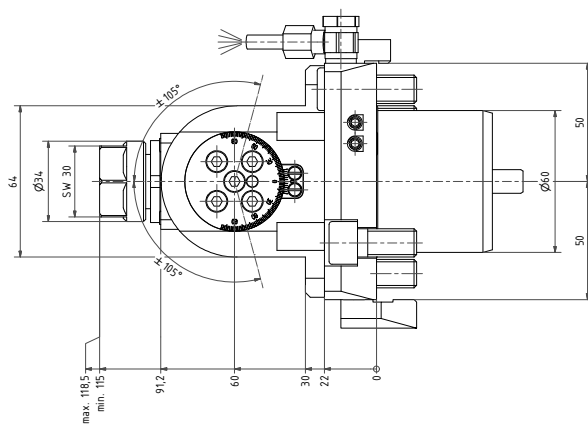

Nr. / No.	i	n _{max}	T _{max}
63.6020LB2000BMT	1:1	6000 1/min	20 Nm

Verzahnungsfräseinrichtung

Gear hobber

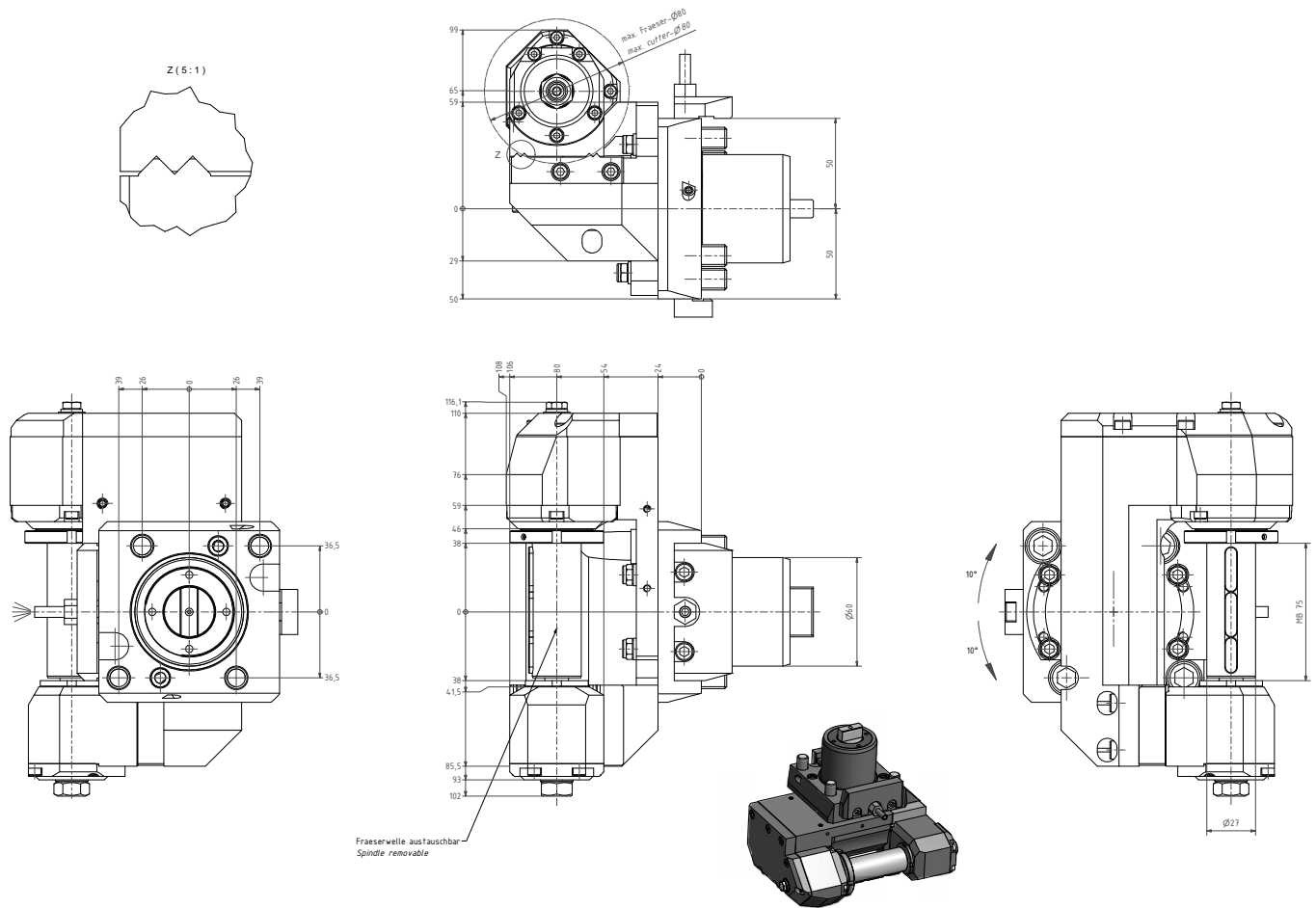

Nr. / No.	i	n _{max}	T _{max}
64.6027LB2000BMT12TKWZ65MB75	2:1	3000 1/min	40 Nm

Scheibenfräskopf

Saw milling head

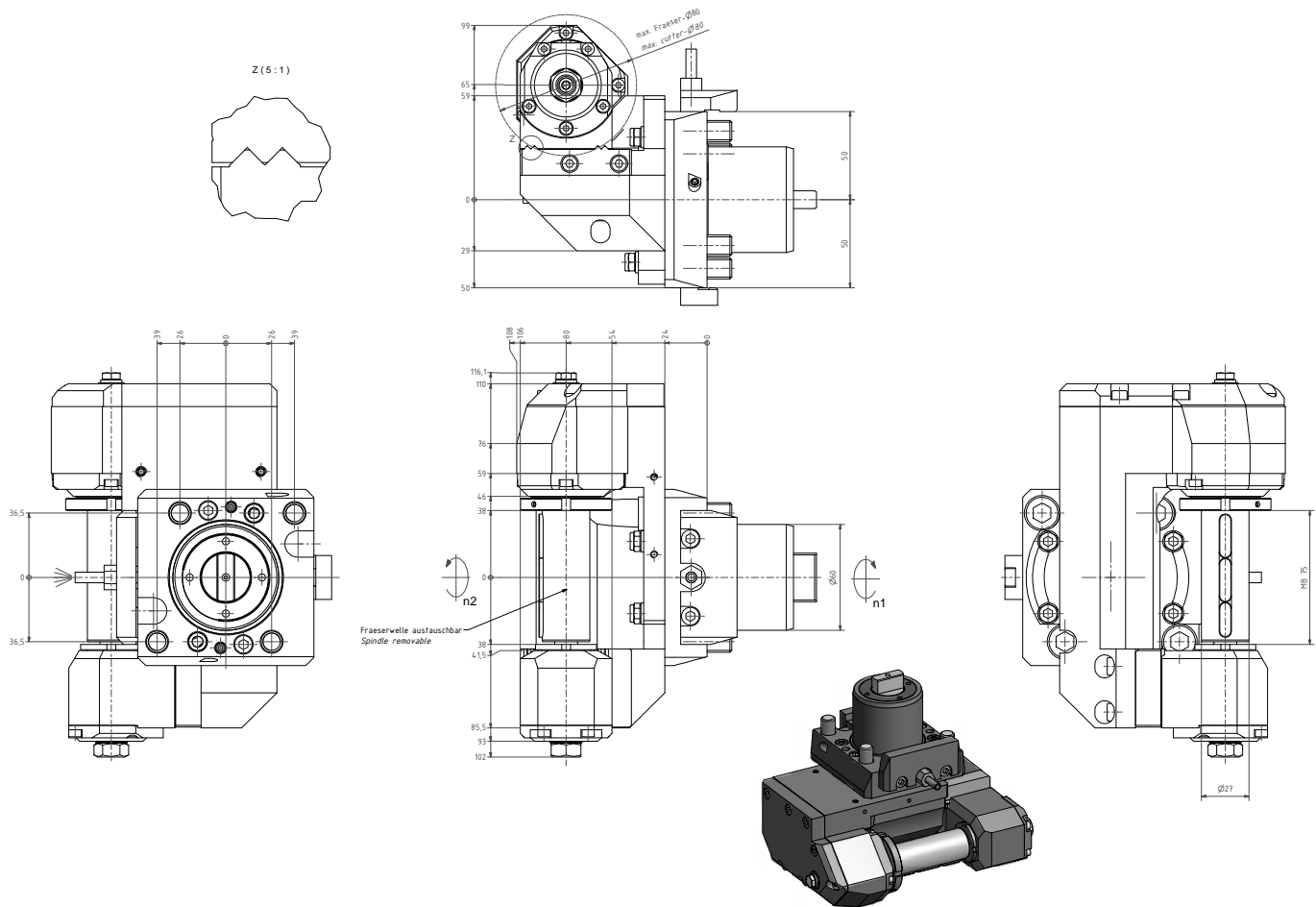

Nr. / No.	i	n _{max}	T _{max}
64.6027LB2000BMT12Z65MB75	2:1	3000 1/min	40 Nm

Andere Fräsdorn Ø auf Anfrage / Other milling arbor Ø on request



**Statische Werkzeuge für Mori Seiki Maschinen SL200,SL250
(12 Stationen)**

Static tools for Mori Seiki machines SL200, SL250 (12 stations)

Porte-outils statiques pour machines Mori Seiki SL200, SL250 (12 stations)

Bohrstangenhalter Boring bar holder Porte barre d'alesage

Mori Seiki SL200 - 200S - 250 - 250S (12 Stationen)

Standard

Bestell Nr. Order No.	d1
19.BMT20SL200	20
19.BMT25SL200	25
19.BMT32SL200	32
19.BMT40SL200	40
19.BMT45SL200	45
19.BMT50SL200	50

für Innen- und Außenkühlung
for internal- and external cooling

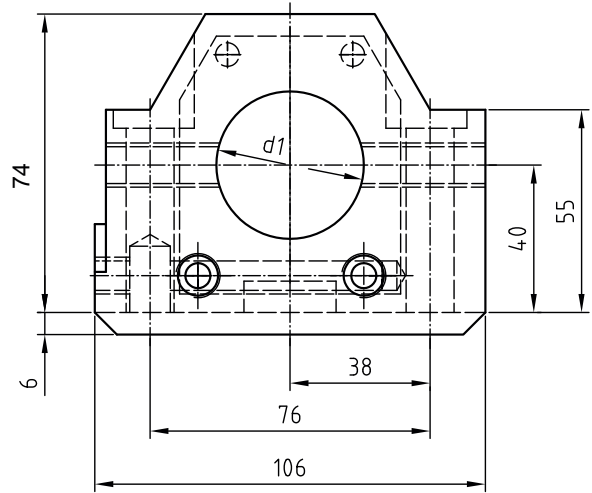
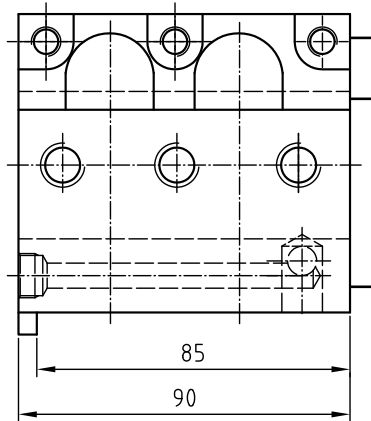

Doppelt / double

Bestell Nr. Order No.	d
19.BMT32DSL200	32

für Innen- und Außenkühlung
for internal- and external cooling

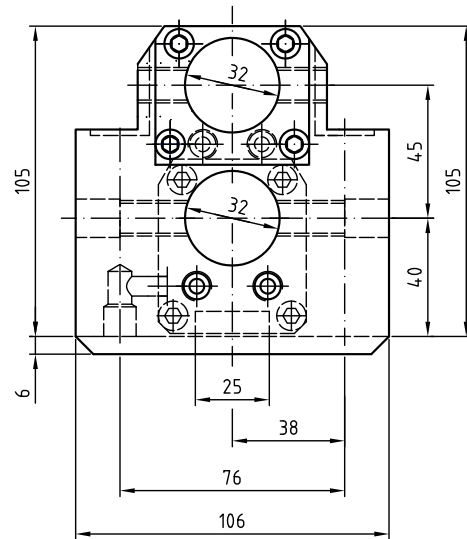
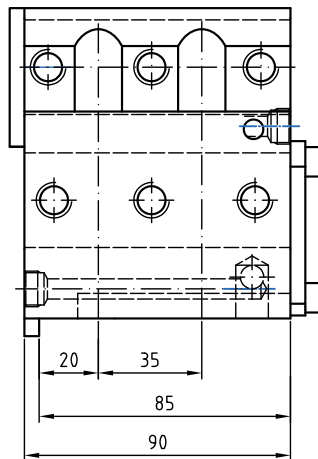

Geschlitzt / slitted

Bestell Nr. Order No.	d1
19.BMT25SL200S01	25
19.BMT32SL200S01	32

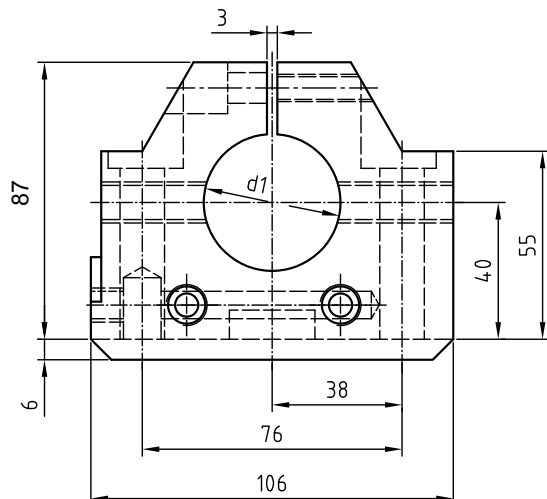
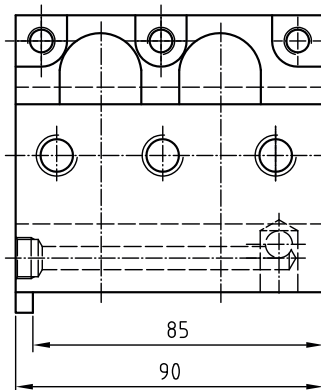

Drehhalter

Turning toolholder

Porte outil

Mori Seiki SL200 - 200S - 250 - 250S (12 Stationen)

Standard

Bestell Nr.
Order No.

1.BMT25SL200S

für Recht- und Linkslauf
for right- and left rotating direction

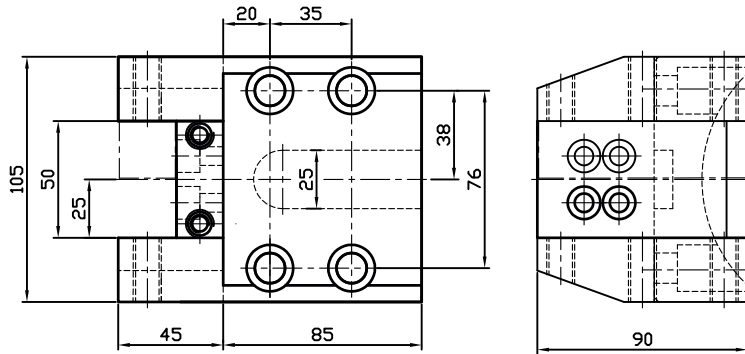

Kurze Ausführung
Short version

Bestell Nr.
Order No.

1.BMT25KSL200

für Recht- und Linkslauf
for right- and left rotating direction

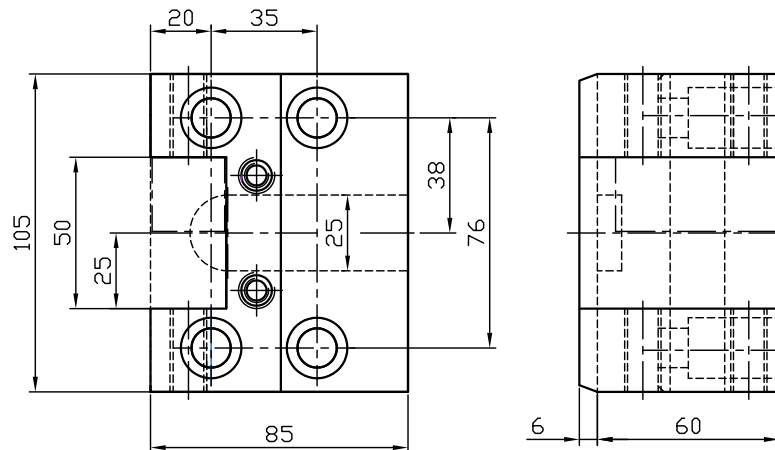

Plandrehhalter

Facing toolholder

Radial porte outil
carré

Standard

Bestell Nr.
Order No.

5.BMT25SL200

für Recht- und Linkslauf
for right- and left rotating direction

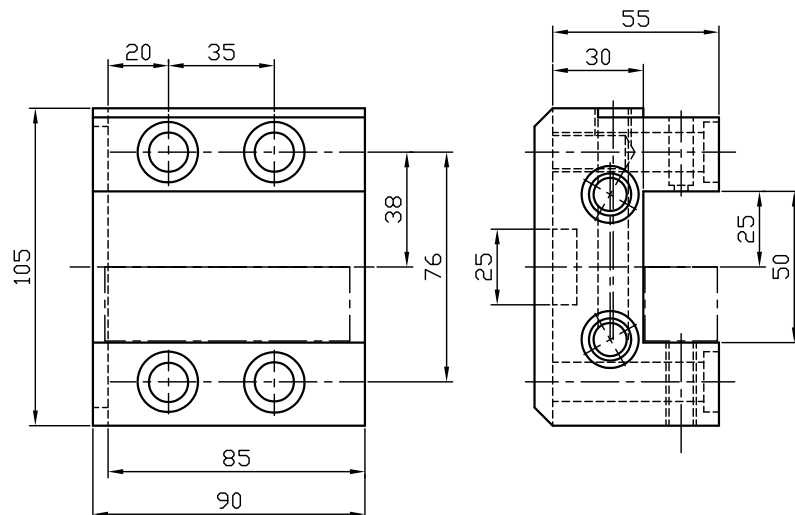

Abstechhalter
höhenverstellbar

Infeed toolholder
height adjustable

Porte outil de plongée
hauteur réglable

Mori Seiki SL200 - 200S - 250 - 250S (12 Stationen)

für Rechts u. Linkslauf

for right and left rotating direction

Bestell Nr.

Order No.

32.BMT32SL200ÜK SH32 Rechtslauf (wie abgebildet)

32.BMT32SL200 SH32 Linkslauf (ohne Abb.)

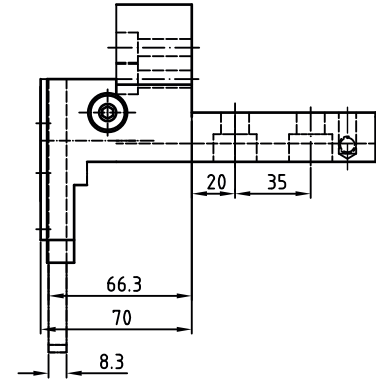
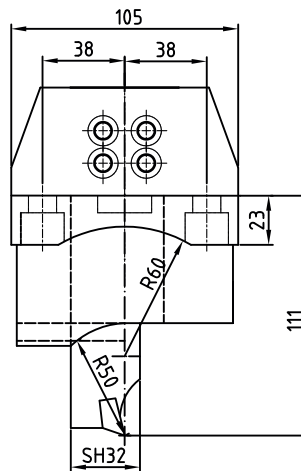

weitere Werkzeuge und Zubehör auf Anfrage

(z.B. Modularesystem EWS-Varia, Capto, ABS, HSK usw.)

more tools and equipment on request

(for example modular system EWS-Varia, Capto, ABS, HSK aso.)



Statische und angetriebene Werkzeuge für Mori Seiki Maschinen

SL200(S)MC,SL250(S)MC (12 Stationen)

Static and driven tools for Mori Seiki machines

SL200(S)MC, SL250(S)MC (12 stations)

Porte-outils statiques et motorisés pour machines

Mori Seiki SL200(S)MC, SL250(S)MC (12 stations)

Bohrstangenhalter Boring bar holder Porte barre d'alesage

Mori Seiki SL200MC - 200SMC - 250MC - 250SMC (12 Stationen)

Standard

Bestell Nr. Order No.	d1
19.BMT20SL200	20
19.BMT25SL200	25
19.BMT32SL200	32
19.BMT40SL200	40
19.BMT45SL200	45
19.BMT50SL200	50

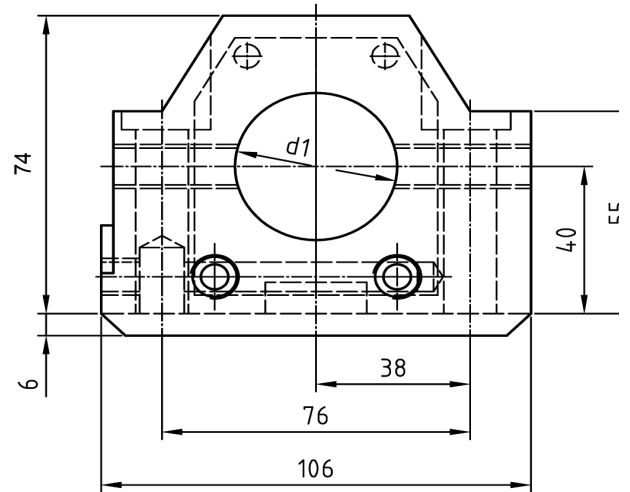
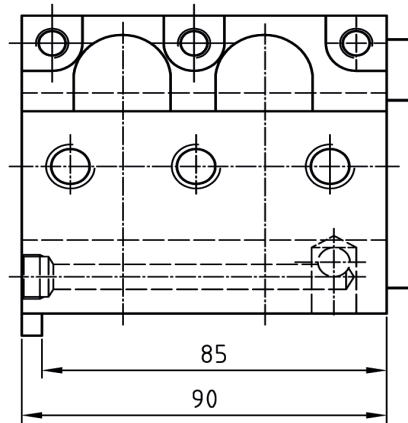

Doppelt / double

Bestell Nr. Order No.	d
19.BMT32DSL200	32
19.BMT32DASL200 zurückgesetzt - offset (nicht gezeichnet - undrawn)	32

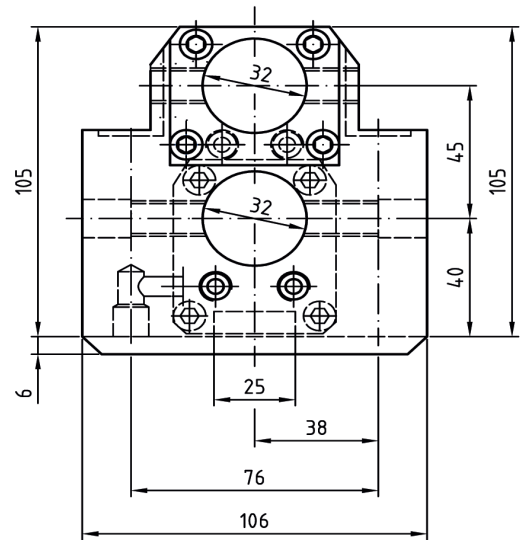
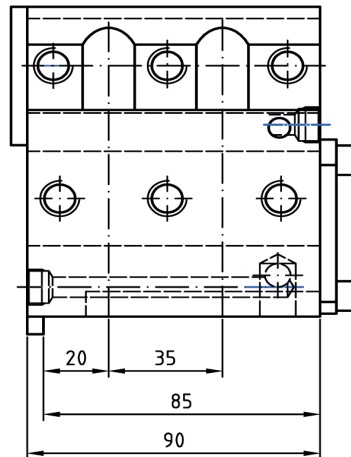

für Innen- und Außenkühlung
for internal- and external cooling

Geschlitzt / slitted

Bestell Nr. Order No.	d1
19.BMT25SL200S01	25
19.BMT32SL200S01	32

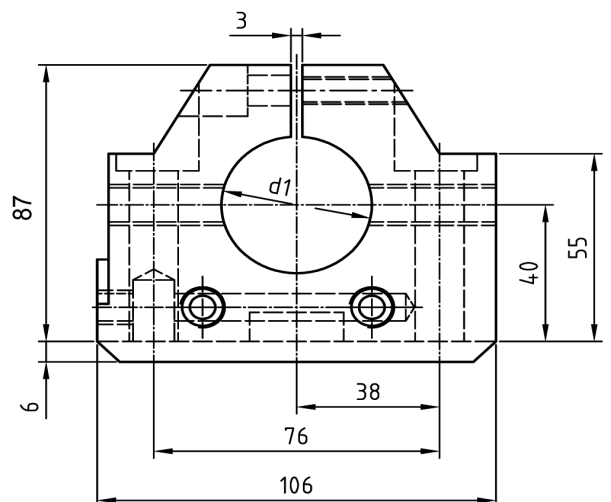
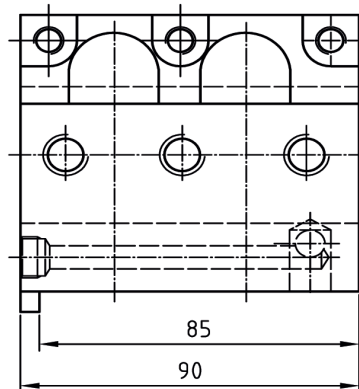

für Innen- und Außenkühlung
for internal- and external cooling

Bohrstangenhalter Boring bar holder Porte barre d'alesage

Mori Seiki SL200MC - 200SMC - 250MC - 250SMC (12 Stationen)

**lange Ausführung /
long version**

Bestell Nr. Order No.	d1
19.BMT40LSL200	40
19.BMT50LSL200	40

für Innen- und Außenkühlung □
for internal- and external cooling

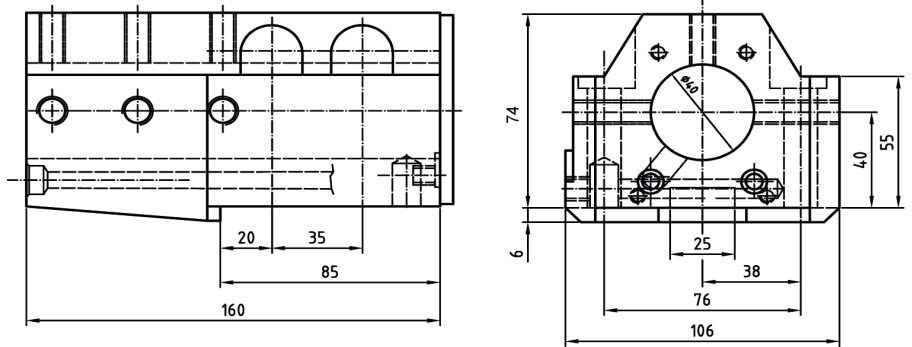

Drehhalter

Turning toolholder

Porte outil

Standard

Bestell Nr. Order No.	
1.BMT25SL200	

für Recht- und Linkslauf
for right- and left rotating direction

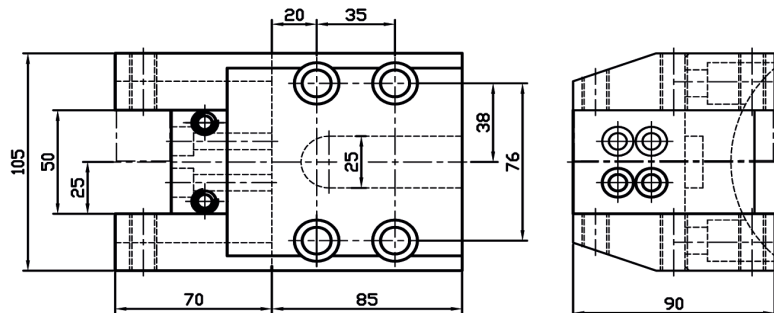

Doppelt / double

Bestell Nr. Order No.	
15.BMT25SL200	

für Recht- und Linkslauf
for right- and left rotating direction

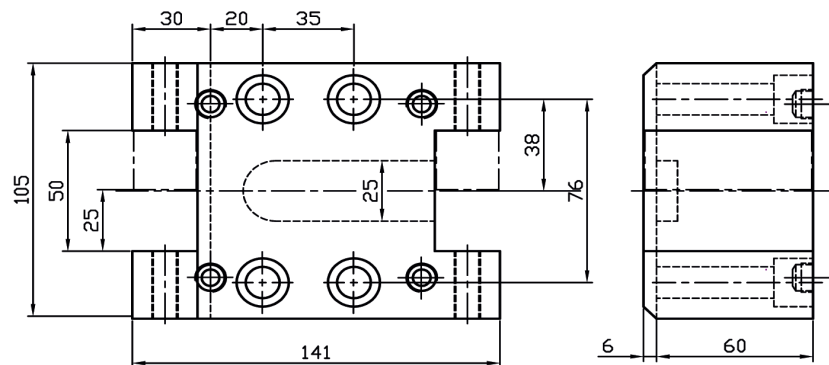

Drehhalter

Turning toolholder

Porte outil

Mori Seiki SL200MC - 200SMC - 250MC - 250SMC (12 Stationen)

Kurze Ausführung
Short version

Bestell Nr.
Order No.

1.BMT25KSL200

für Recht- und Linkslauf
for right- and left rotating direction

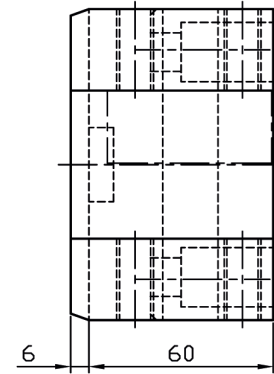
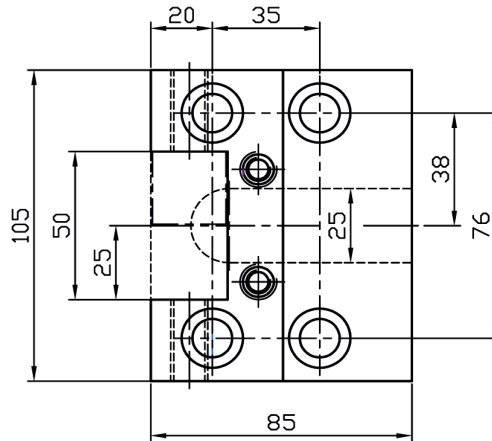

Lange Ausführung
long version

Bestell Nr.
Order No.

5.BMT25LSL200

für Recht- und Linkslauf
for right- and left rotating direction

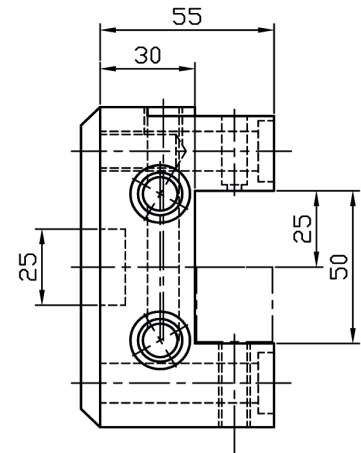
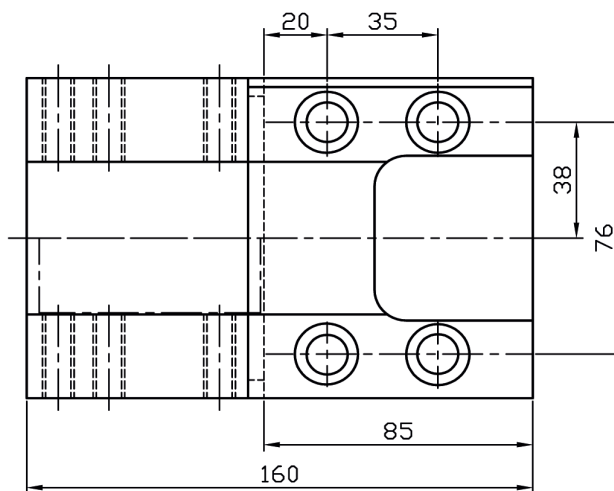

Abstechhalter

Infeed toolholder

Porte outil de plongée

höhenverstellbar

height adjustable

hauteur réglable

für Rechts u. Linkslauf
for right and left rotating direction

für Recht- und Linkslauf
for right- and left rotating direction

Order No.

32.BMT32SL200ÜK SH32 Rechtslauf (wie abgebildet)

32.BMT32SL200 SH32 Linkslauf

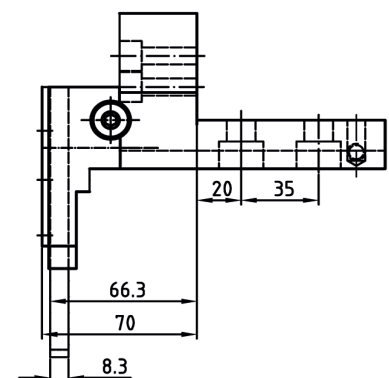
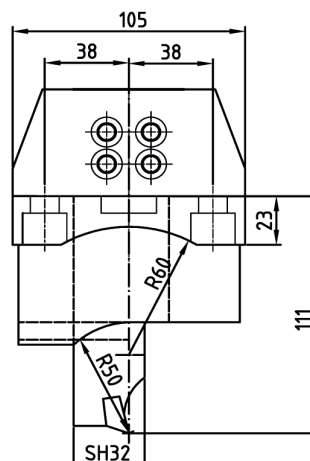

**Axial Bohr-
und Fräskopf**

**Axial drilling and
milling head**

**Tête de perçage et
fraisage**

Mori Seiki SL200MC - 200SMC - 250MC - 250SMC (12 Stationen)

Bestell Nr.
Order No.

40.3232SL200BMT mit ext. Kühlung /
with ext. coolant

40.3232SL200BMTIK mit ext. u. int. Kühlung /
with ext. and int. coolant

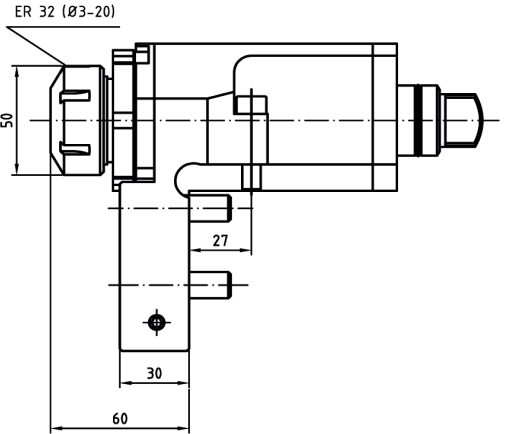
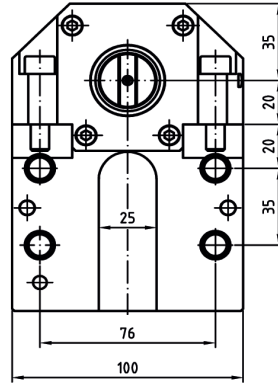

**Radial Bohr-
und Fräskopf**

**Radial drilling and
milling head**

**Tête de perçage et
fraisage radial**

Bestell Nr.
Order No.

60.3232SL200BMT mit ext. Kühlung /
with ext. coolant

60.3232SL200BMTIK mit ext. u. int. Kühlung /
with ext. and int. coolant

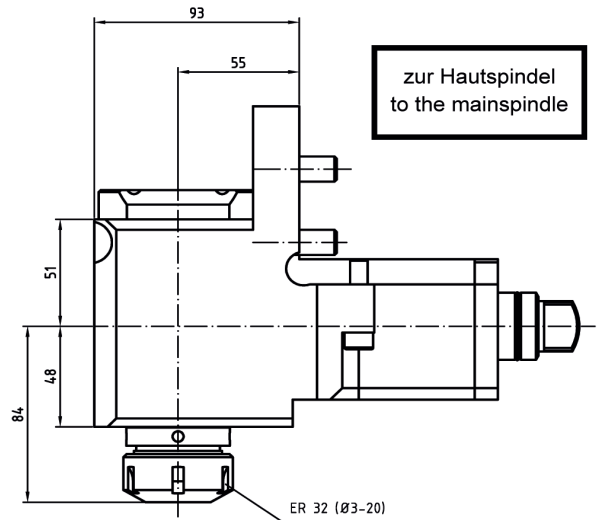
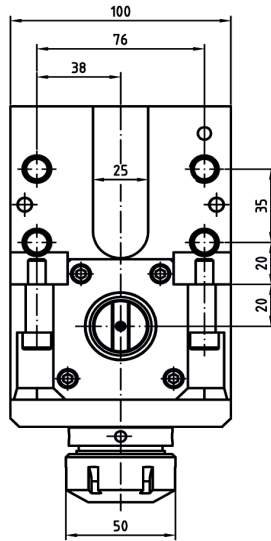

Bestell Nr.
Order No.

60.3232SL200BMTL mit ext. Kühlung /
with ext. coolant

60.3232SL200BMTLIK mit ext. u. int. Kühlung /
with ext. and int. coolant

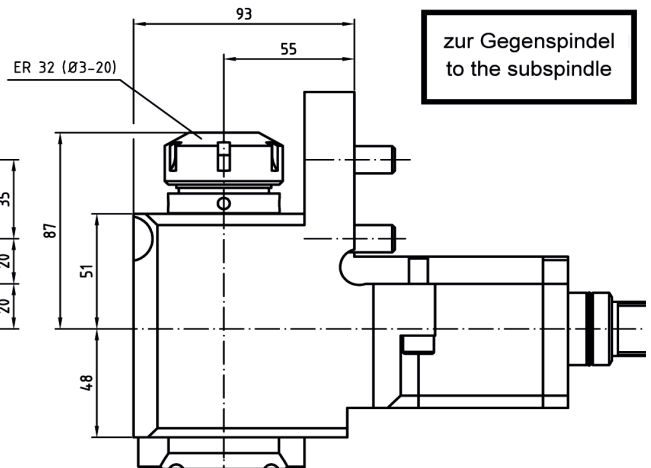
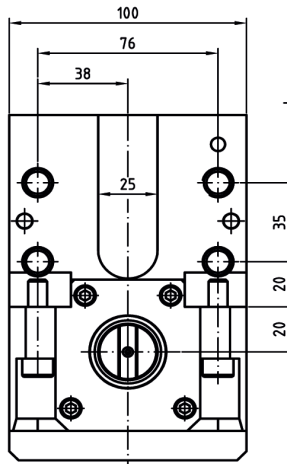

**Radial Bohr-
und Fräskopf**

**Radial drilling and
milling head**

**Tête de perçage et
fraisage radial**

Mori Seiki SL200MC - 200SMC - 250MC - 250SMC (12 Stationen)

Doppelt / double

Bestell Nr.
Order No.

60.3232DSL200BMT

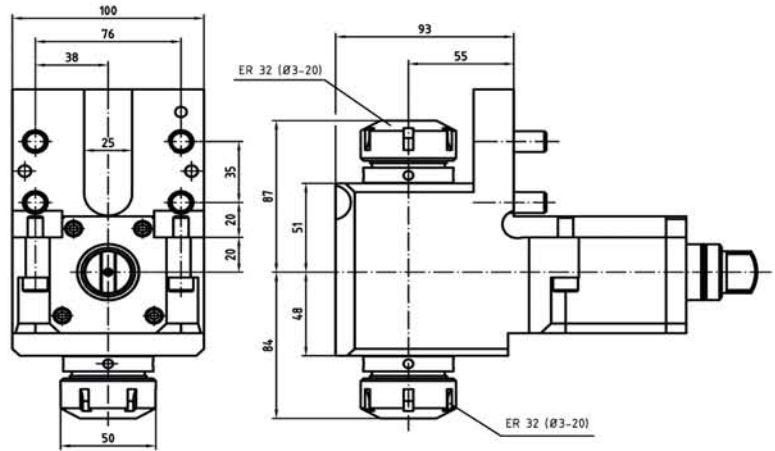

Bestell Nr.
Order No.

60.3232KRSL200BMT

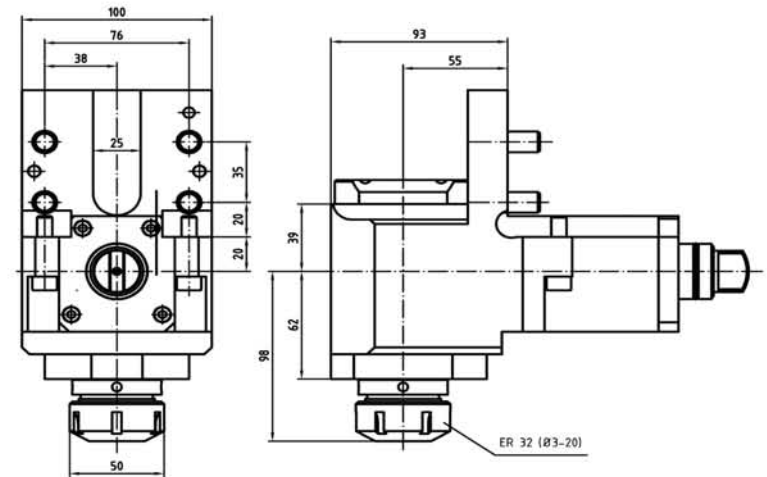

**Schwenkkopf
±105°**

**Swivel level
±105°**

**Tête pivotante
±105°**

Bestell Nr. Spzg Winkel
Order No. i collet angle

63.3225SL200BMT 1:1 ER25 ±105°
wie gezeichnet

63.3225SL200BMTS01 1:1 ER25 +135°/-60°
ohne Abbildung

63.3225SL200BMT 1:1 ER25 ±105°
ohne Abbildung

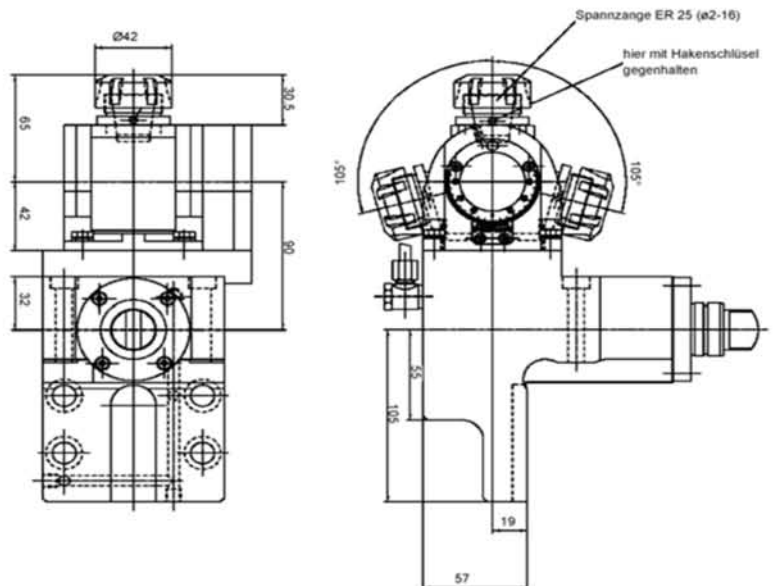



Statische und angetriebene Werkzeuge für Mori Seiki Maschinen

NL-1500/2000/2500/3000

Static and driven tools for Mori Seiki machines

NL-1500/2000/2500/3000

Porte-outils statiques et motorisés pour machines

NL-1500/2000/2500/3000

Außendrehhalter

OD-holder

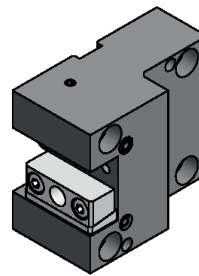
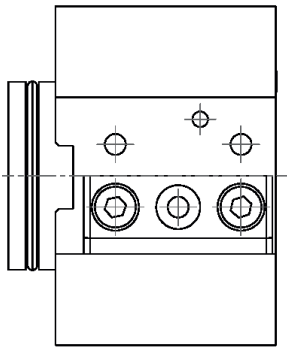
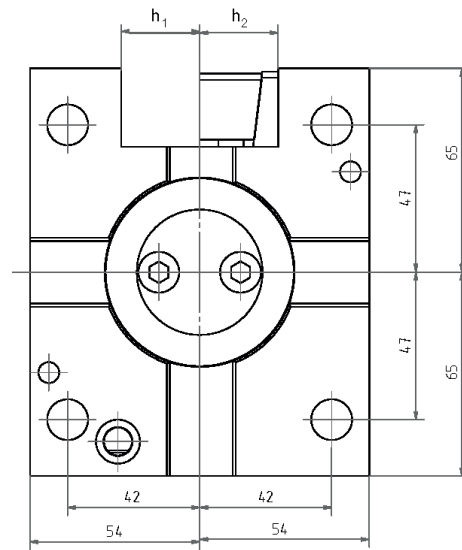
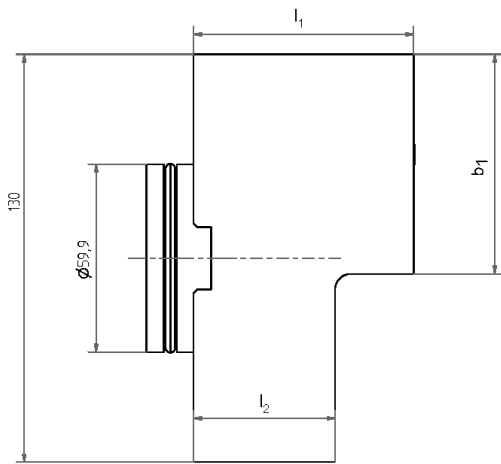

Nr. / No.	l1	l2	b1	h1	h2
4.BMT25NLX70	70	45	70	25	25
4.BMT25.4NLX70	70	45	70	25,4	25,4
4.BMT25NLX95	95	35	40	25	25
4.BMT25.4NLX95	95	35	40	25,4	25,4

Außendrehhalter

OD-holder

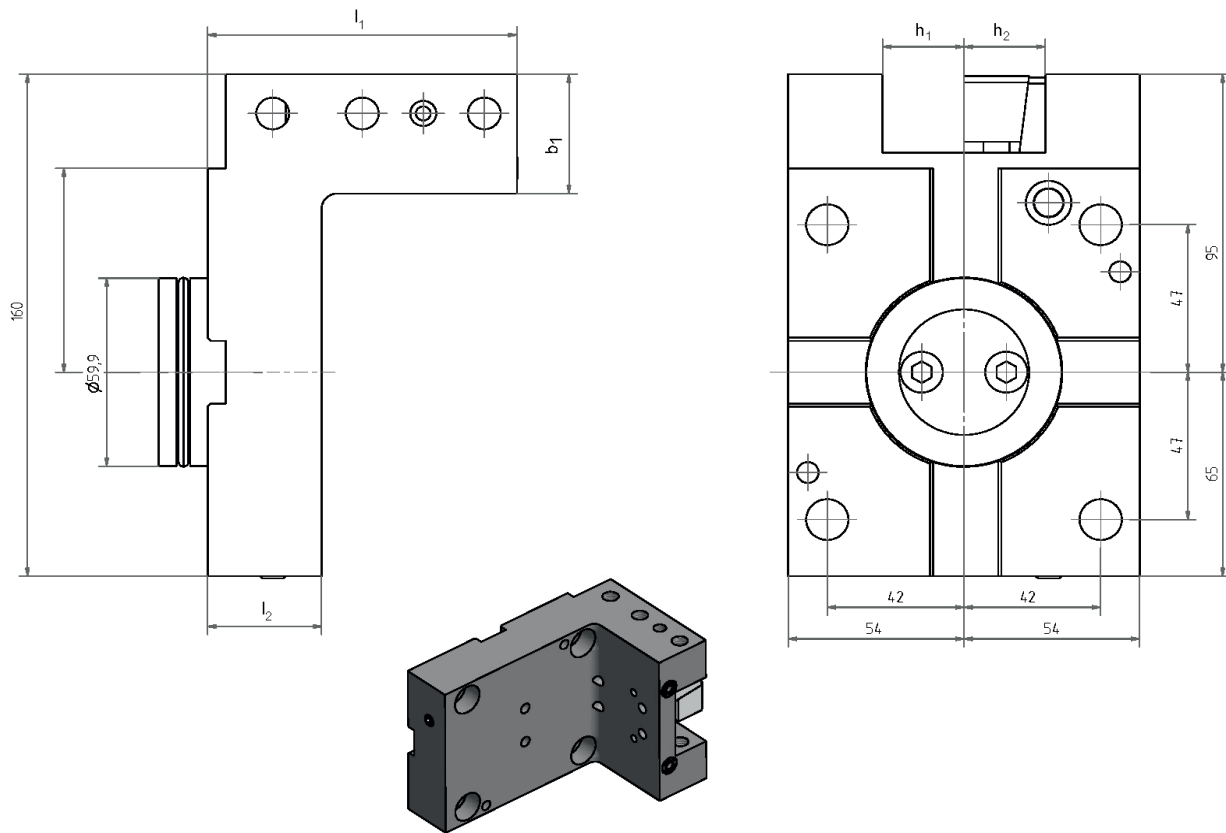

Nr. / No.	l1	l2	b1	h1	h2
1.BMT25NLX70	70	45	70	25	25
1.BMT25.4NLX70	70	45	70	25,4	25,4
1.BMT25NLX95	95	35	38	25	25
4.BMT25.4NLX95	95	35	38	25,4	25,4

Doppel - Außendrehhalter

Double OD-holder

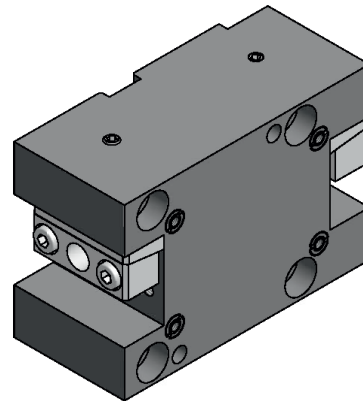
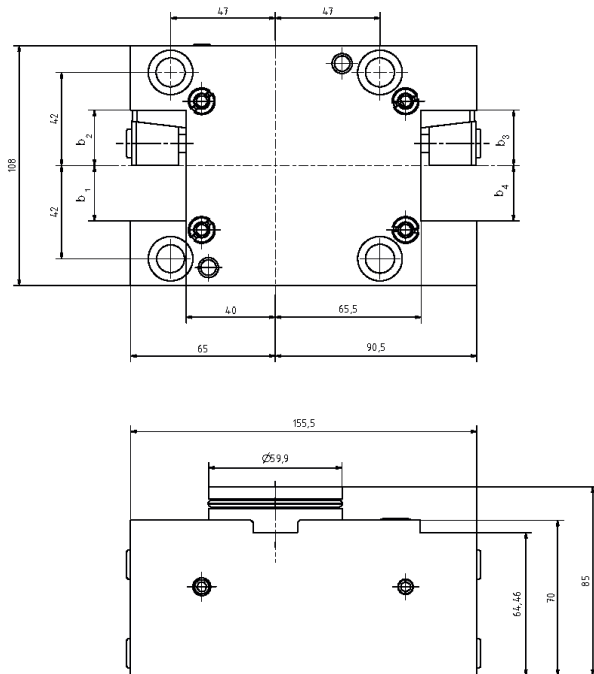

Nr. / No.	b1	b2	b3	b4
15.BMT25NL	25	25	25	25
15.BMT25.4NL	25,4	25,4	25,4	25,4

Plandrehhalter

Facing holder

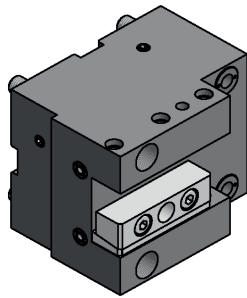
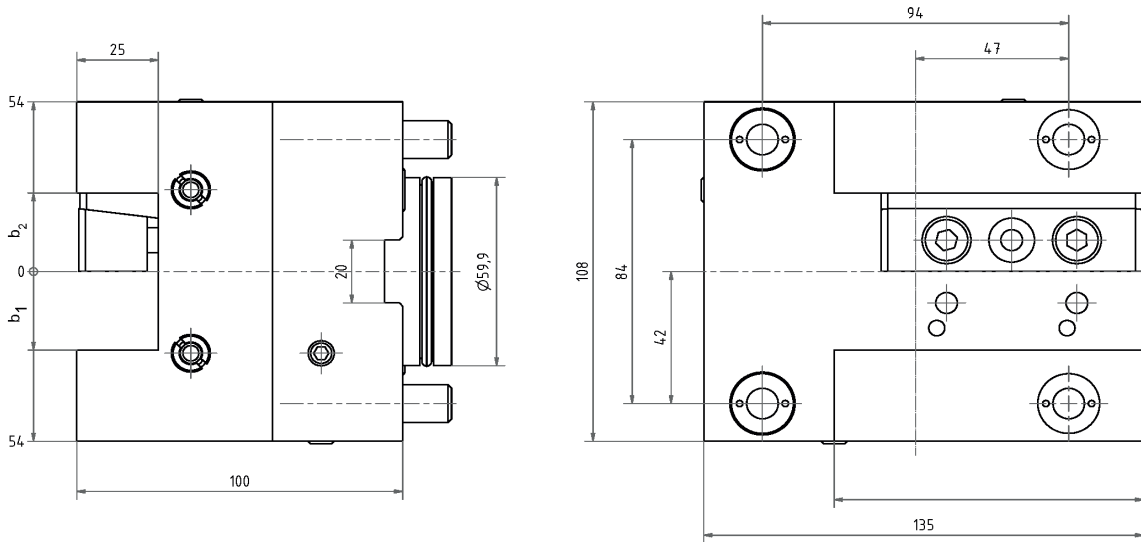

Nr. / No.	b1	b2
8.BMT25NL	25	25
8.BMT25.4NL	25,4	25,4

Kombihalter

Combi holder

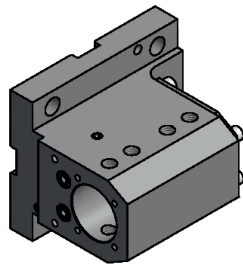
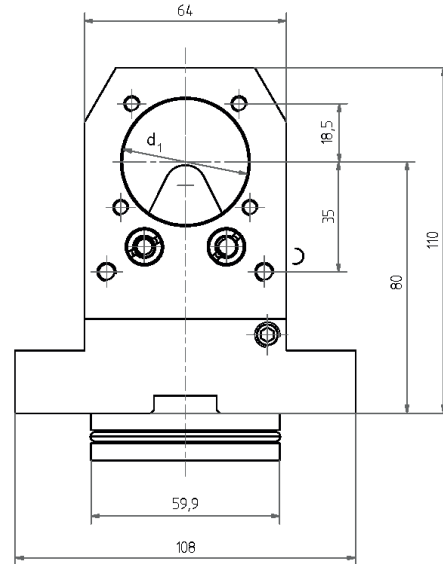
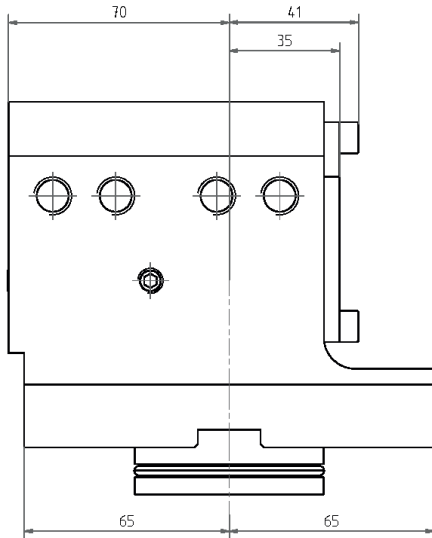

Nr. / No.	d1
17.BMT19.05NL	19,05
17.BMT20NL	20
17.BMT25NL	25
17.BMT25,4NL	25,4
17.BMT31.75NL	31,75
17.BMT32NL	32
17.BMT38.1NL	38,1
17.BMT40NL	40
17.BMT50NL	50
17.BMT50.8NL	50,8

Kombihalter

Combi holder

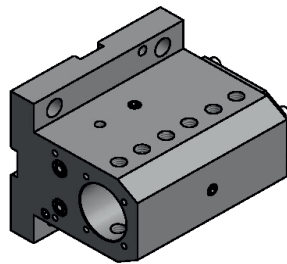
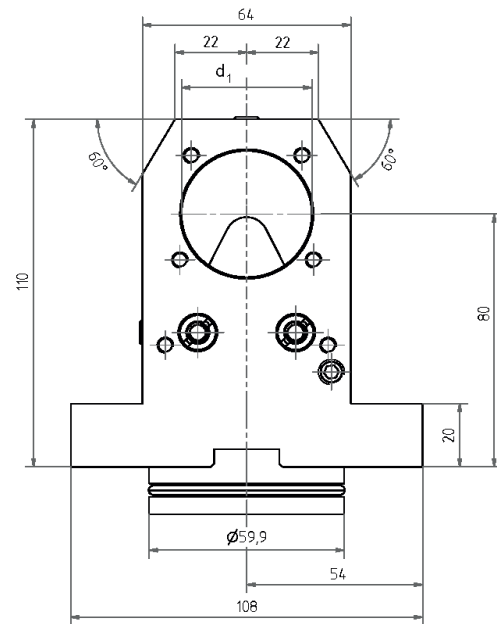
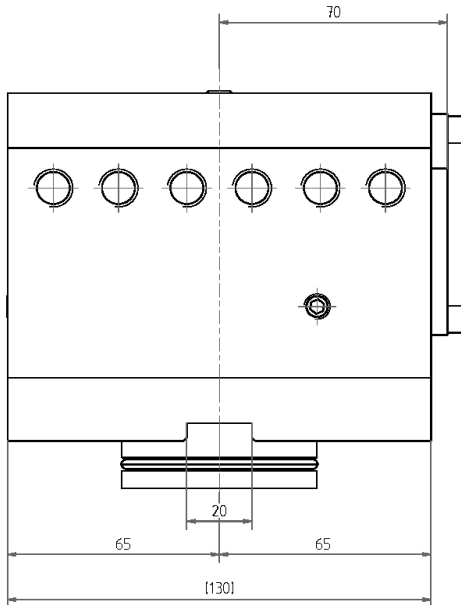

Nr. / No.	d1
17.BMT19.05DNL	19,05
17.BMT20DNL	20
17.BMT25DNL	25
17.BMT25.4DNL	25,4
17.BMT31.75DNL	31,75
17.BMT32DNL	32
17.BMT38.1DNL	38,1
17.BMT40DNL	40
17.BMT50DNL	50
17.BMT50.8DNL	50,8

Doppel Bohrstangenaufnahme Double boring bar holder

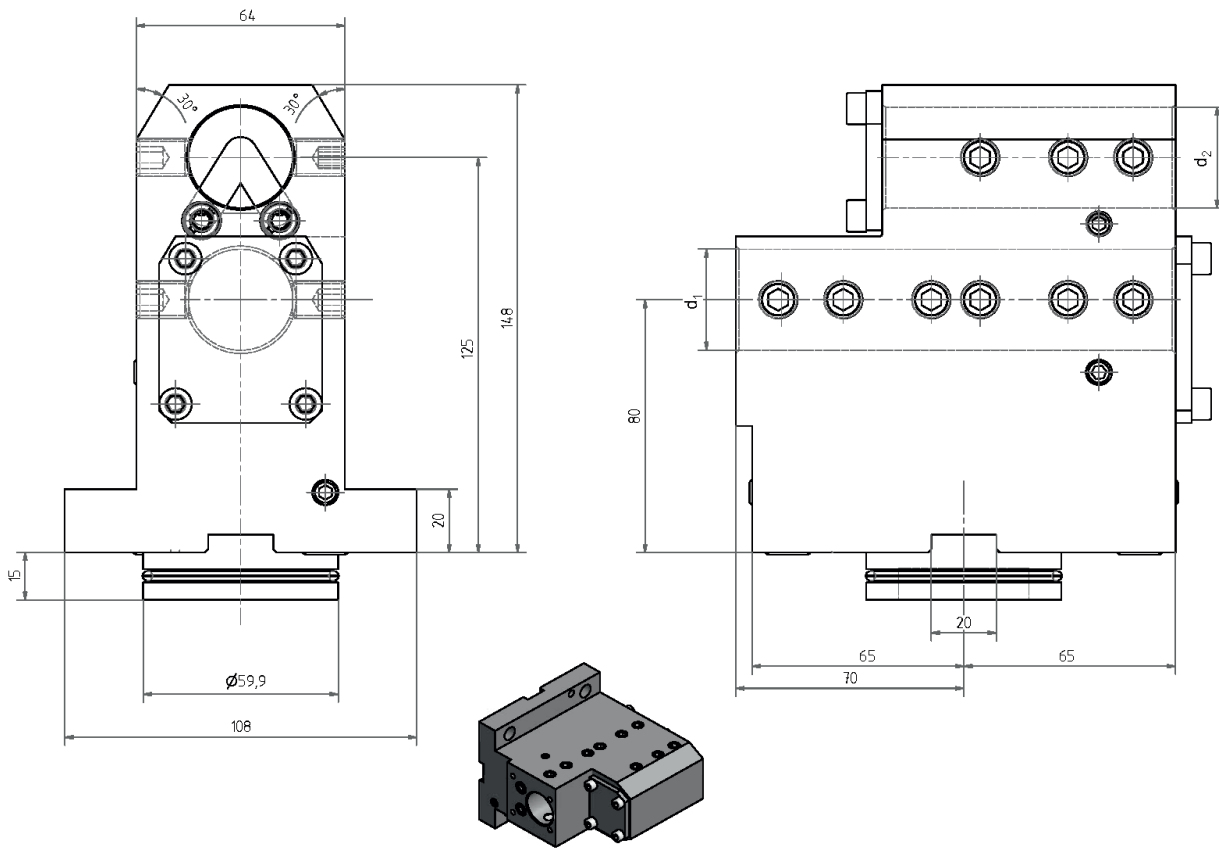

Nr. / No.	d1	d2
19.BMT31.75DNLX80X125	31,75	31,75
19.BMT32DNLX80X125	32	32

Axial Bohr- und Fräskopf

Axial drilling and milling head

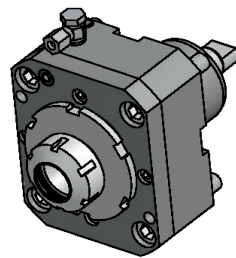
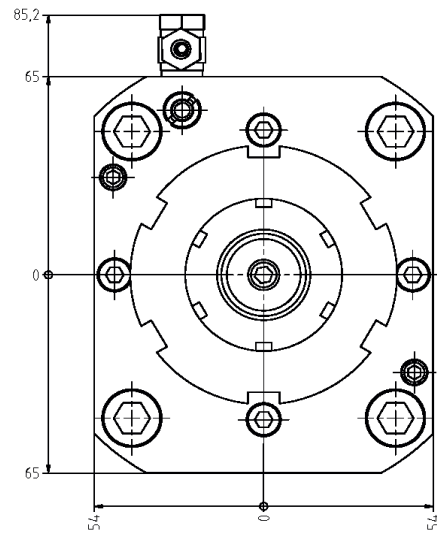
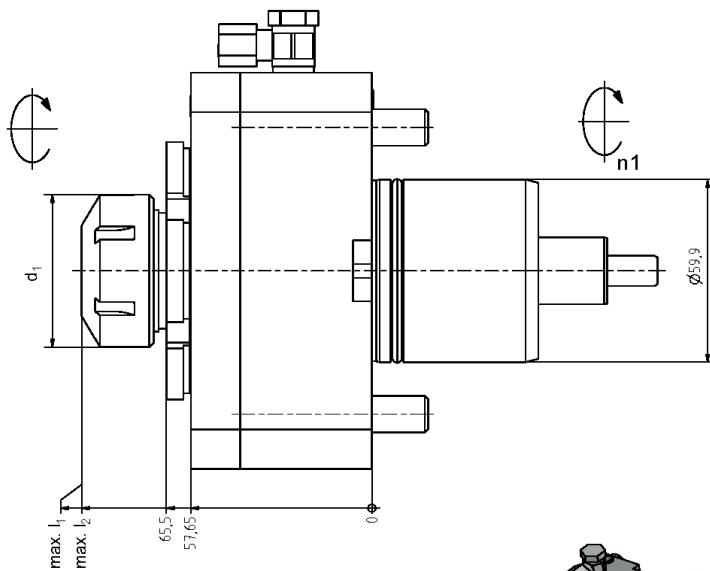

Nr. / No.	l1	l2	n1	n2
40.6032NL	90	93,5	6000 1/min	6000 1/min
40.6032NLIK	90	93,5	6000 1/min	6000 1/min
40.6032KRNL	90	93,5	4000 1/min	4000 1/min
40.6040NL	94,5	98	6000 1/min	6000 1/min
40.6040KRNL	94,5	98	4000 1/min	4000 1/min
40.6040KRNLIK	94,5	98	4000 1/min	4000 1/min

IK = Innere Kühlung
IK = Internal cooling

Axial

Bohr- und Fräskopf

EWS Varia

Axial

drilling and milling head

EWS Varia

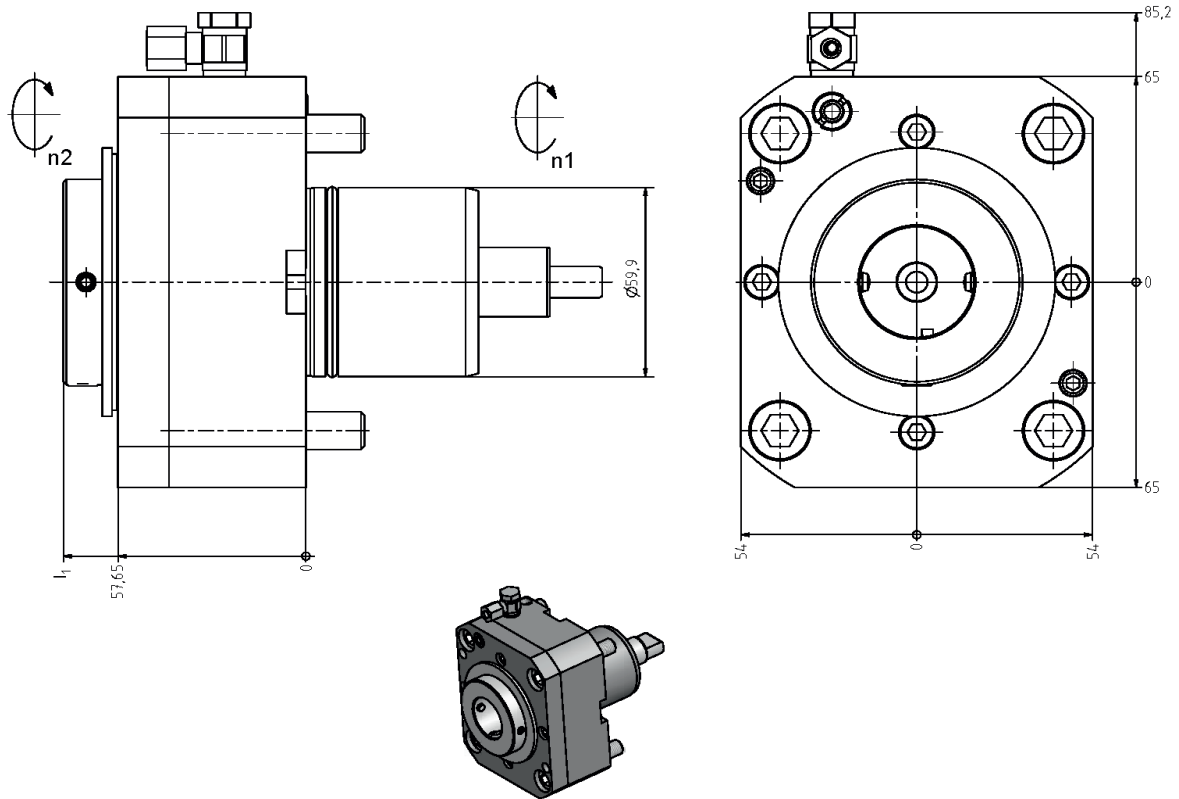

Nr. / No.	l1	n1	n2
40.60V4NL	74,5	6000 1/min	6000 1/min
40.60V4NLIK	74,5	6000 1/min	6000 1/min

IK = Innere Kühlung
IK = Internal cooling

Radial Bohr- und Fräskopf

Radial drilling and milling head

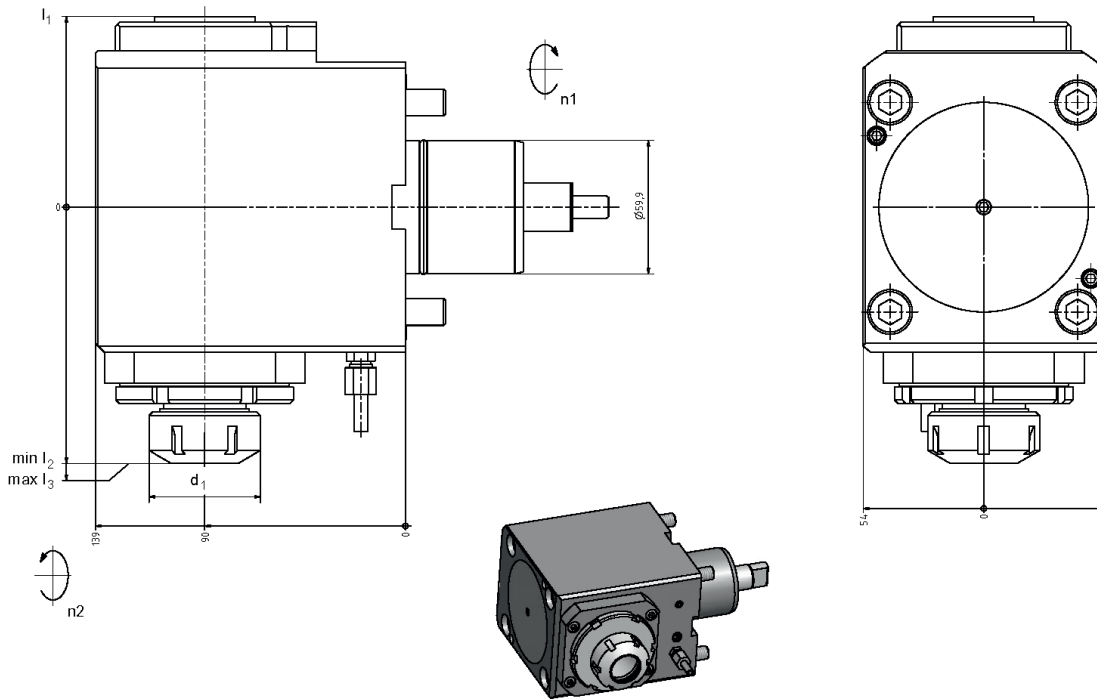

Nr. / No.	l1	l2	l3	d1	n1	n2
60.6032NL	85,5	116,5	120	50	6000 1/min	6000 1/min
60.6032NLIK	85,5	116,5	120	50	6000 1/min	6000 1/min
60.6032NLi1	85,5	112,5	116	50	6000 1/min	12000 1/min
60.6032NLi1IK	94,5	112,5	116	50	6000 1/min	12000 1/min
60.6032KRNL	85,5	116,5	120	50	4000 1/min	4000 1/min
60.6032KRNLIK	85,5	116,5	120	50	4000 1/min	4000 1/min
60.6040NL	85,5	118,5	120	63	6000 1/min	6000 1/min
60.6040NLIK	85,5	118,5	120	63	6000 1/min	6000 1/min
60.6040KRNL	85,5	118,5	122	63	4000 1/min	4000 1/min
60.6040KRNLIK	85,5	118,5	122	63	4000 1/min	4000 1/min
60.6040NLIK1	94,5	114,5	118	63	6000 1/min	12000 1/min

IK = Innere Kühlung
IK = Internal cooling

Radial
Bohr- und Fräskopf
doppelseitig

Radial
drilling and milling head
double side

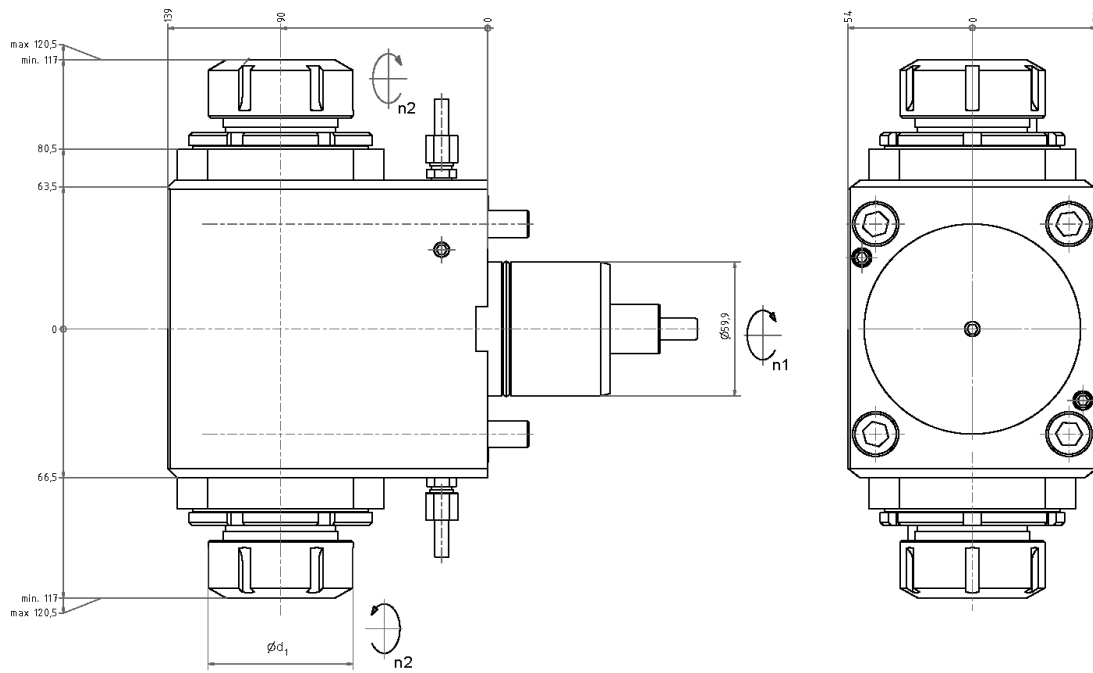

Nr. / No.	d1	n1	n2
60.6040DNL	63	6000 1/min	6000 1/min

Radial Bohr- und Fräskopf

EWS Varia

Radial drilling and milling head

EWS Varia

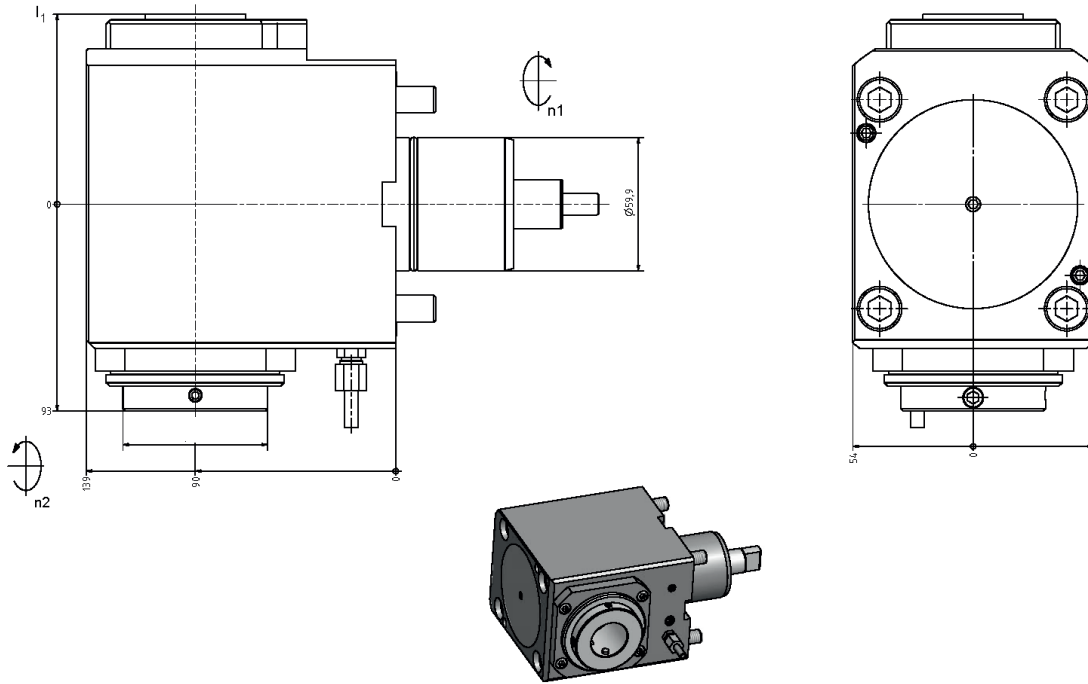

Nr. / No.	l1	n1	n2
60.60V4NL	85,5	6000 1/min	6000 1/min
60.60V4NLIK	85,5	6000 1/min	6000 1/min
60.60V4NLI1	85,5	6000 1/min	12000 1/min
60.60V4NLIK1	94,5	6000 1/min	12000 1/min

IK = Innere Kühlung
IK = Internal cooling



Statische und angetriebene Werkzeuge für Mori Seiki Maschinen

ZT1000/ZT1500/MT1500

Static and driven tools for Mori Seiki machines

ZT1000/ZT1500/MT1500

Porte-outils statiques et motorisés pour machines

ZT1000/ZT1500/MT1500

Kombihalter

Combiholder

Porte outil combiné

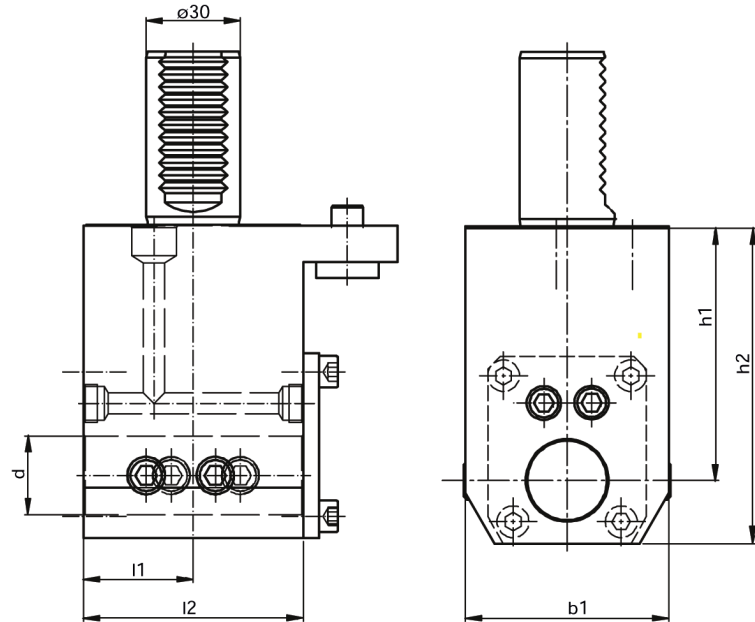

für Innen- und Außenkühlung
for internal- and external cooling

Bestell Nr. Order No.	d	h1	h2	l1	l2	b1
17.3025ZT1000	25	80	105,5	35	70	64
17.3032ZT1000	32	80	105,5	35	70	64
17.3025ZT1000X65	25	65	90,5	35	70	64
17.3032ZT1000X65	32	65	90,5	35	70	64
17.3025.4ZT1000	25.4	80	105,5	35	70	64
17.3031.75ZT1000	31.75	80	105,5	35	70	64
17.3025.4ZT1000X65	25.4	65	90,5	35	70	64
17.3031.75ZT1000X65	31.75	65	90,5	35	70	64

Kombihalter

Combiholder

Porte outil combiné

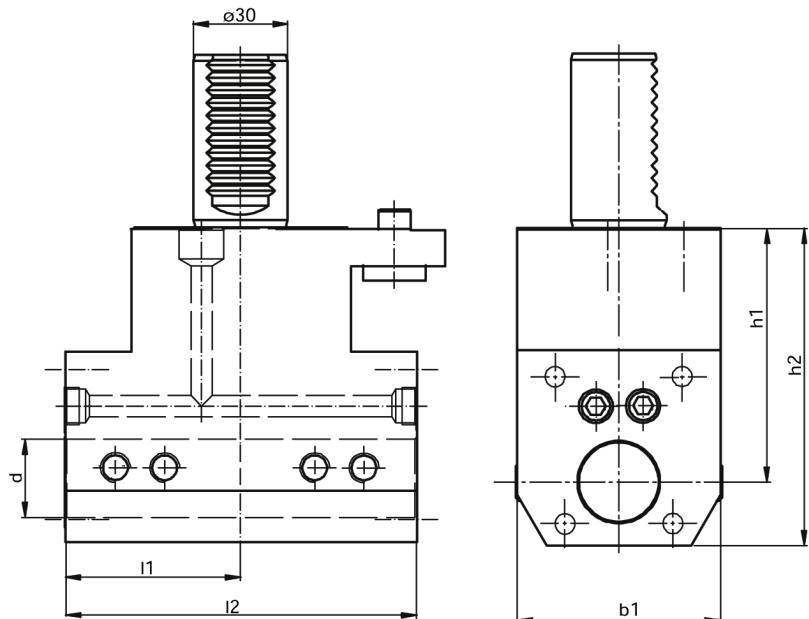

Bestell Nr. Order No.	d	h1	h2	l1	l2	b1
17.3025DZT1000	25	80	105,5	59	118	64
17.3032DZT1000	32	80	105,5	59	118	64
17.3031.75DZT1000	31,75	80	105,5	59	118	64

Spannzangenaufnahme

collet chuck

Porte pince

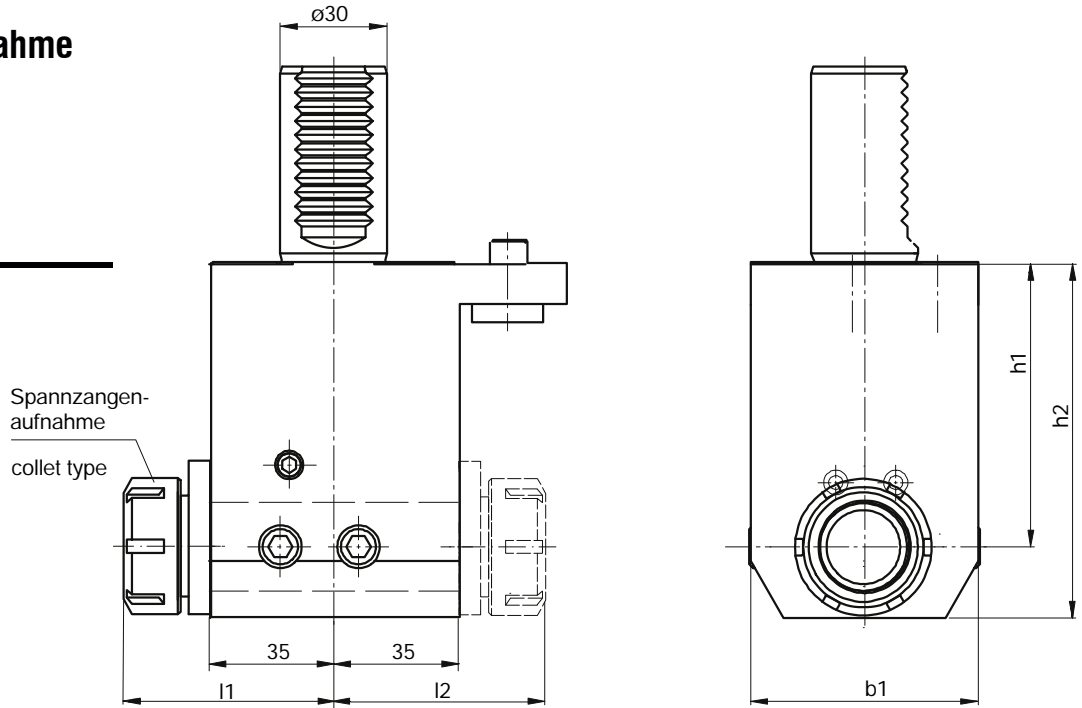

Bestell Nr.	h_1	h_2	l_1	l_2	b_1	d_2	
31.3025ZT1000X65	65	90,5	70	70	64	42	RD/ER 25 430E (ø2-16)
31.3032ZT1000X65	65	90,5	80	80	64	50	RD/ER 32 470E (ø3-20)
31.3025DZT1000X65	65	90,5	70	70	64	42	RD/ER 25 430E (ø2-16)
31.3032DZT1000X65	65	90,5	80	80	64	50	RD/ER 32 470E (ø3-20)
31.3025ZT1000	80	105,5	70	70	64	42	RD/ER 25 430E (ø2-16)
31.3032ZT1000	80	105,5	80	80	64	50	RD/ER 32 470E (ø3-20)
31.3025DZT1000	80	105,5	70	70	64	42	RD/ER 25 430E (ø2-16)
31.3032DZT1000	80	105,5	80	80	64	50	RD/ER 32 470E (ø3-20)

Kombihalter

Combiholder

Porte outil combiné

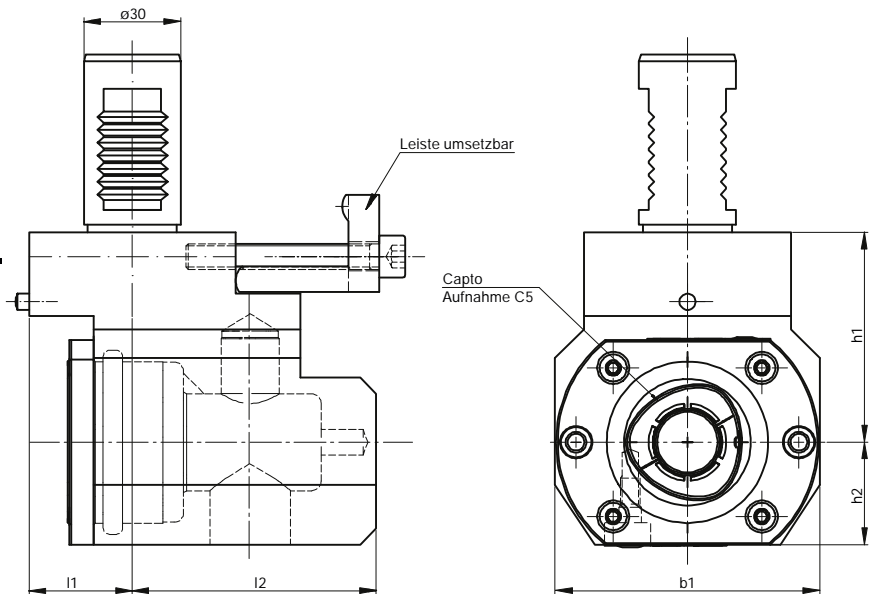

Bestell Nr.	d	h_1	h_2	l_1	l_2	b_1	Werkzeugaufnahme tool adaptor
19.30C5ZT1000LIK	C5	65	97	20	95,5	82	Capto C5
19.30C5ZT1000RIK	C5	65	97	20	95,5	82	Capto C5
19.30C5ZT1000RLIK	C5	65	97	20	95,5	82	Capto C5

**Vierkant-
Mehrfachaufnahme**

**Multi purpose
square tool holder**

**Radial-axial porte
outil carré universelle**

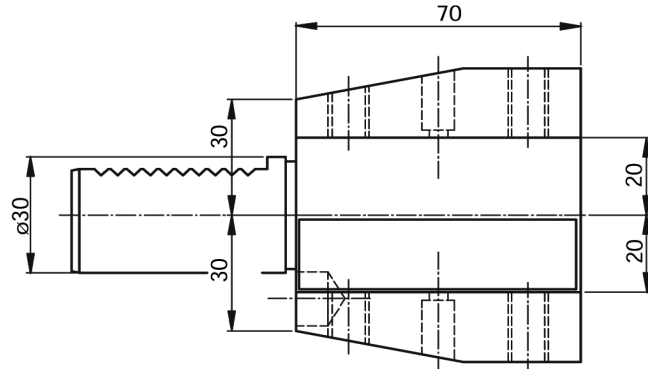
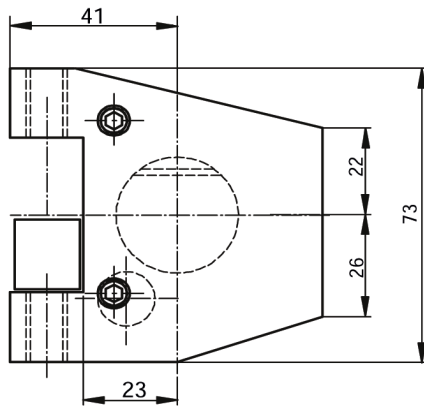

Bestell Nr. Order No.	Stahlhöhe square
3.3020ZT1000	VK 20
3.3019.05ZT1000	VK 19.05 (1")

**Vierkant-
Mehrfachaufnahme**

**Multi purpose
square tool holder**

**Radial-axial porte
outil carré universelle**

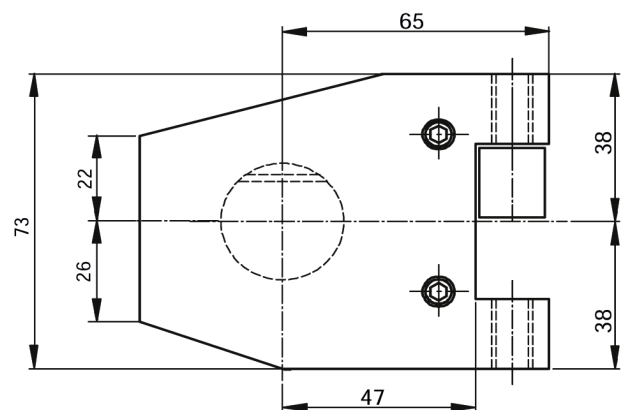
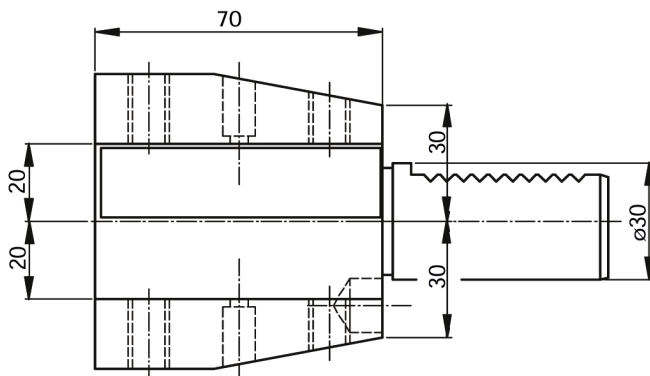

Bestell Nr. Order No.	Stahlhöhe square
1.3020ZT1000	VK 20
1.3019.05ZT1000	VK 19.05 (1")

Doppel-drehhalter

Double turning toolholder

Porte outil double coté

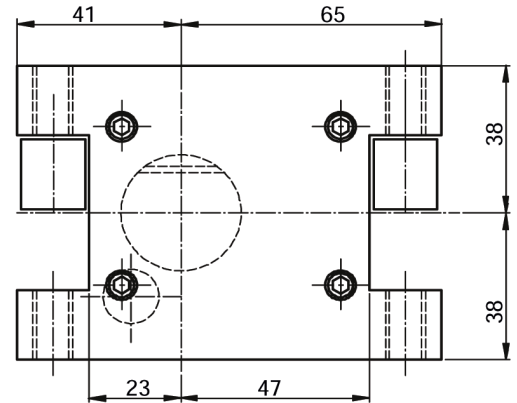
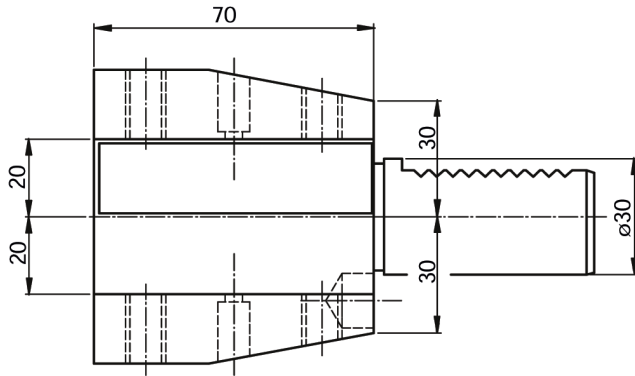

Bestell Nr. Order No.	Stahlhöhe square
15.3020ZT1000	VK 20
15.3019.05ZT1000	VK 19.05 (1")

Abstechhalter höhenverstellbar

Infeed Toolholder hight adjustable

Porte outil plongée, réglable

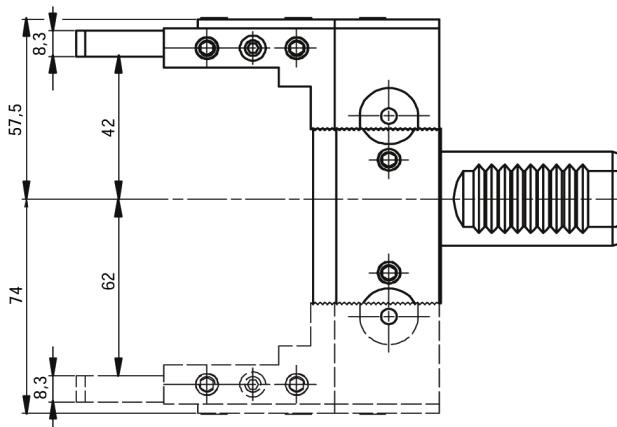
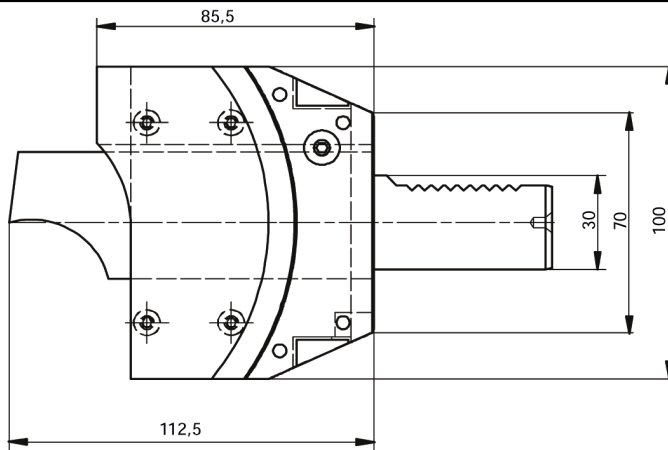

Bestell Nr. Order No.	Stahlhöhe size
32.3032ZT1000LÜK	SH 32
32.3032ZT1000L	SH 32
32.3032ZT1000RÜK	SH 32
32.3032ZT1000R	SH 32

Bestell Nr. Order No.	Stahlhöhe size
32.3026ZT1000LÜK	SH 26
32.3026ZT1000L	SH 26
32.3026ZT1000RÜK	SH 26
32.3026ZT1000R	SH 26

Vierkant- Queraufnahme

Turning tool- holder radial

Radial porte outil carré

Bestell Nr. Order No.	Stahlhöhe square
5.3020ZT1000	VK 20
5.3019.05ZT1000	VK 19.05 (1")

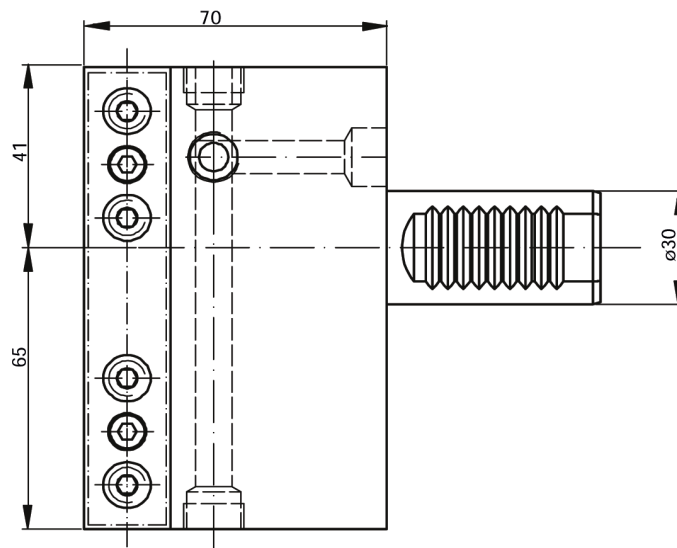
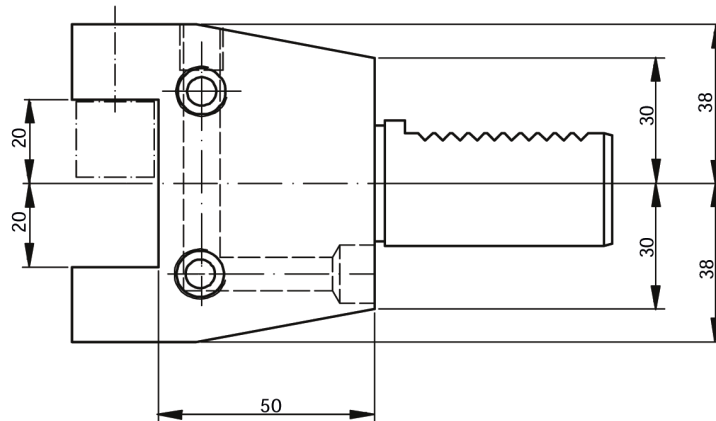

Axial Bohr-
und Fräskopf

Axial drilling and
milling head

Tête de perçage et
fraisage

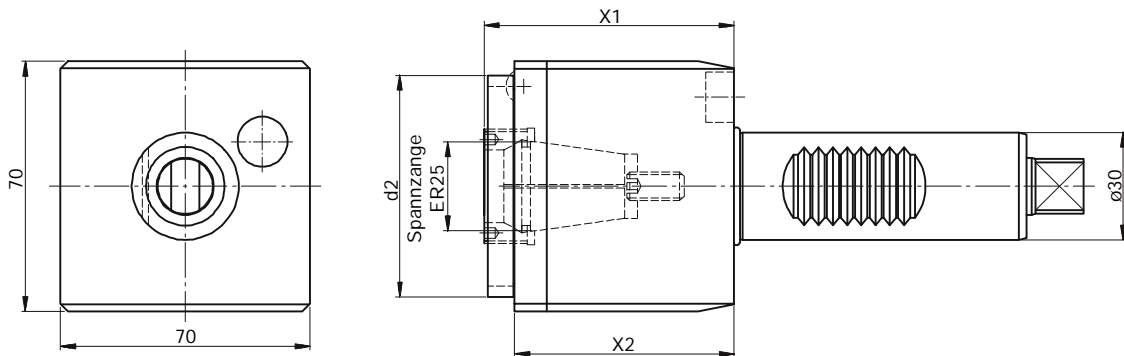

Bestell Nr Order No.	i	n_{max} [1/min]	T_{max} [Nm]	x1	x2	b1	d2	Werkzeugaufnahme
40.3025ZT1000	1:1	6000	25	73	65,5	70	62	RD/ER 25 430E (2-16)
40.3025ZT1000IK	1:1	6000	25	73	65,5	70	62	RD/ER 25 430E (2-16)

Axial Fräskopf

Axial milling head

Tête de fraisage

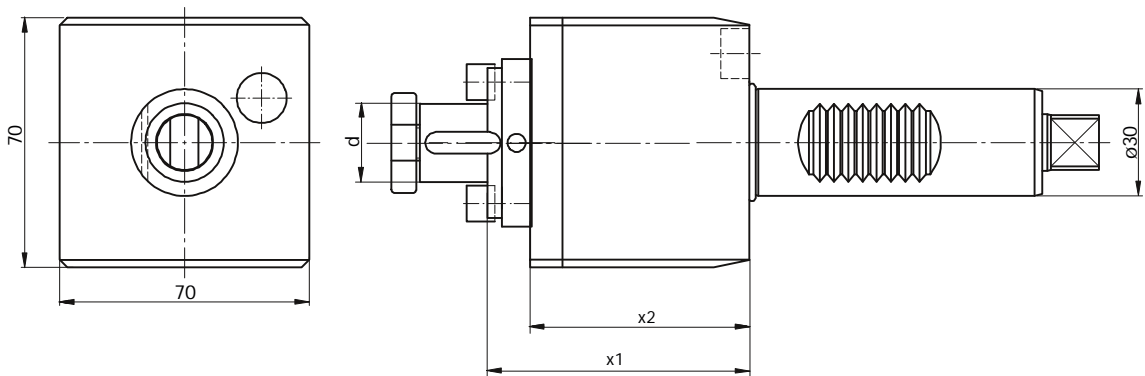

Bestell Nr Order No.	i	n_{max} [1/min]	T_{max} [Nm]	x1	x2	b1	d
42.3013ZT1000	1:1	6000	25	73	65,5	70	13
42.3016ZT1000	1:1	6000	25	73	65,5	70	16
42.3022ZT1000	1:1	6000	25	73	65,5	70	22

Radial Bohr-
und Fräskopf

Radial drilling and
milling head

Tête de perçage et
fraisage radial

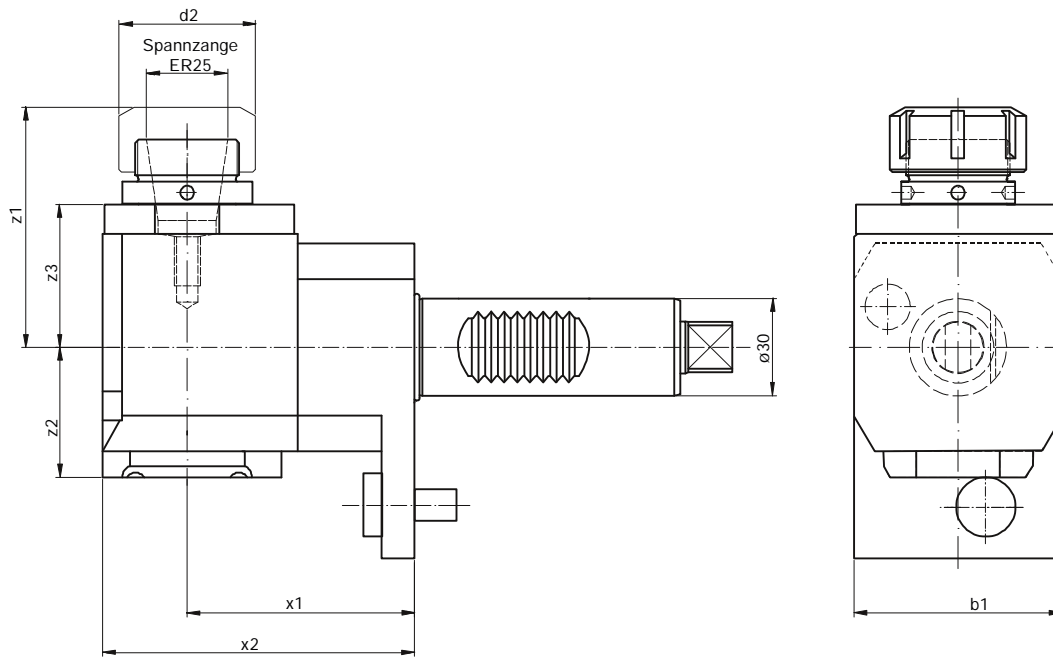

Bestell Nr Order No.	i	n_{max} [1/min]	T_{max} [Nm]	x1	x2	z1	z2	z3	b1	d2	Werkzeugaufnahme
60.3025ZT1000L	1:1	6000	25	70	95	65	41	35	64	42	RD/ER 25 430E (2-16)
60.3025ZT1000R	1:1	6000	25	70	95	65	41	35	64	42	RD/ER 25 430E (2-16)
60.3025ZT1000LIK	1:1	6000	25	70	95	65	59,5	35	64	42	RD/ER 25 430E (2-16)
60.3025ZT1000RIL	1:1	6000	25	70	95	65	59,5	35	64	42	RD/ER 25 430E (2-16)

Radial Bohr-
und Fräskopf

Radial drilling and
milling head

Tête de perçage et
fraisage radial

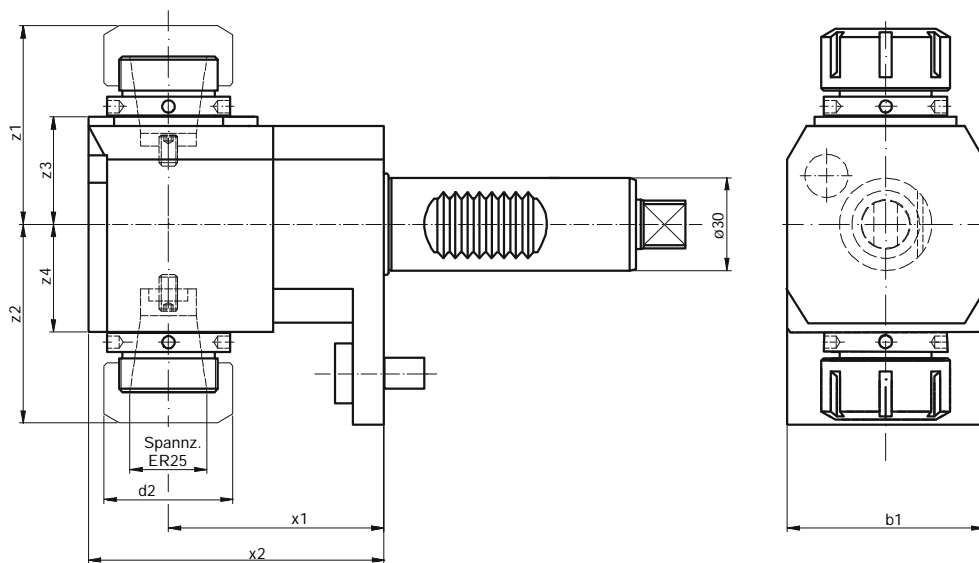

Bestell Nr Order No.	i	n_{max} [1/min]	T_{max} [Nm]	x1	x2	z1	z2	z4	b1	b2	d2	Werkzeugaufnahme
60.3025DZT1000	1:1	6000	25	70	95	65	65	35	35	64	42	RD/ER 25 430E (2-16)

Radial Bohr- und Fräskopf

Radial drilling and milling head

Tête de perçage et fraisage radial

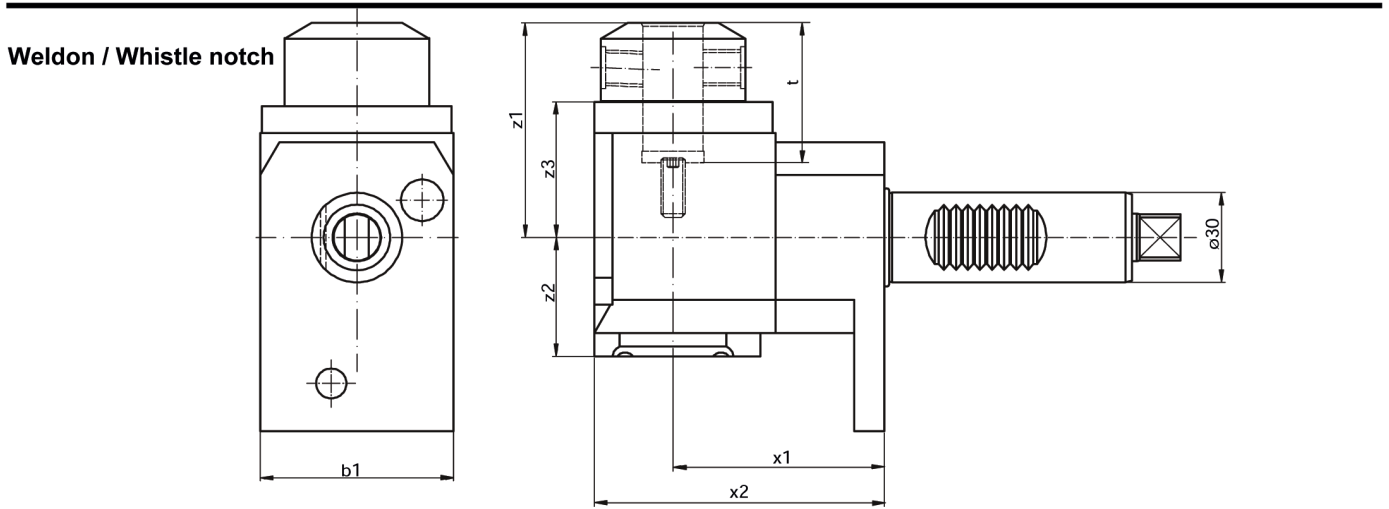

Bestell Nr Order No.	i	n_{max} [1/min]	T_{max} [Nm]	x1	x2	z1	z2	z3	b1	d2	t	Werkzeug- aufnahme
60.3016WNZT1000L	1:1	6000	25	70	95	69	41	35	64	48	45	16
60.3016WNZT1000R	1:1	6000	25	70	95	69	41	35	64	48	45	16
60.3020WNZT1000L	1:1	6000	25	70	95	72	41	35	64	48	47	20
60.3020WNZT1000R	1:1	6000	25	70	95	72	41	35	64	48	47	20
60.3016WNZT1000LIK	1:1	6000	25	70	95	69	59,5	35	64	48	45	16
60.3016WNZT1000RIK	1:1	6000	25	70	95	69	59,5	35	64	48	45	16
60.3020WNZT1000LIK	1:1	6000	25	70	95	72	59,5	35	64	48	47	20
60.3020WNZT1000RIK	1:1	6000	25	70	95	72	59,5	35	64	48	47	20

Radial Fräskopf

Radial milling head

Tête de fraisage radial

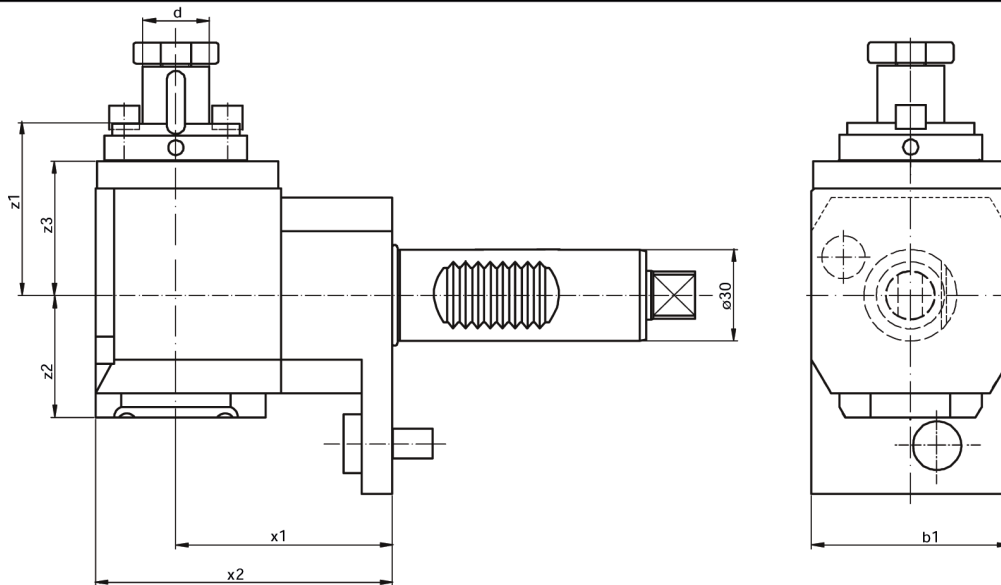

Bestell Nr Order No.	i	n_{max} [1/min]	T_{max} [Nm]	x1	x2	z1	z2	z3	b1	d
62.3013ZT1000L	1:1	6000	25	70	95	63,5	41	35	64	13
62.3013ZT1000R	1:1	6000	25	70	95	63,5	41	35	64	13
62.3016ZT1000L	1:1	6000	25	70	95	58	41	35	64	16
62.3016ZT1000R	1:1	6000	25	70	95	58	41	35	64	16
62.3022ZT1000L	1:1	6000	25	70	95	58	41	35	64	22
62.3022ZT1000R	1:1	6000	25	70	95	58	41	35	64	22

Schwenkkopf
+/- 105 °

Swivel head
+/- 105 °

Tête pivotante
+/- 105 °

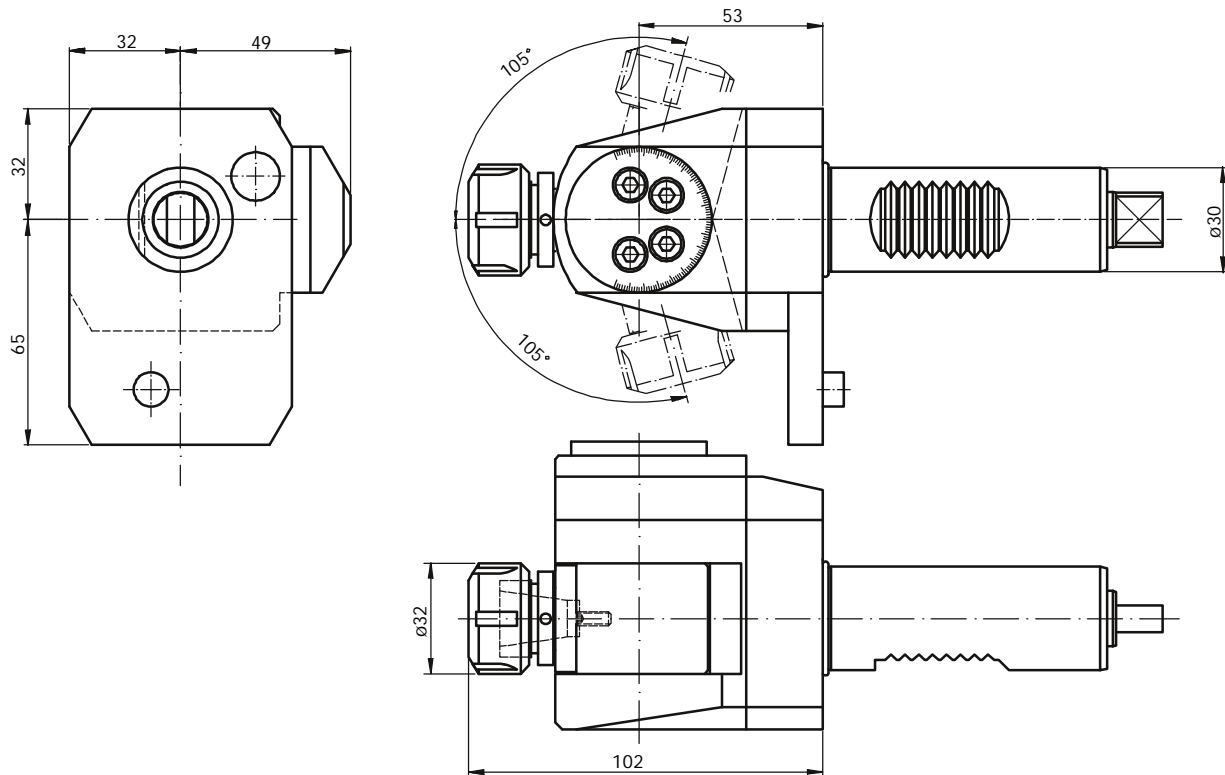

Bestell Nr Order No.	i	n_{\max} [1/min]	T_{\max} [Nm]	Werkzeug- aufnahme
63.3016ZT1000i1	1:2	12000	8	RD/ER 16 426E (1-10)

weitere Werkzeuge und Zubehör auf Anfrage

(z.B. Modularsystem EWS-Varia, Capto, ABS, HSK usw.)

more tools and equipment on request

(for example modular system EWS-Varia, Capto, ABS, HSK aso.)



HSK- und Capto-Werkzeuge

*HSK and Capto tools
Porte-outils HSK et Capto*

HSK- und Capto-Werkzeuge
HSK and Capto tools
Porte outils HSK et Capto

			Form	Page
HSK 63A	HSK 63A	HSK 63A		1 - 11
Capto C6	Capto C6	Capto C6		1 - 15



HSK Werkzeuge

HSK tools

Porte-outils HSK

Spannzangenaufnahme

Collet chuck

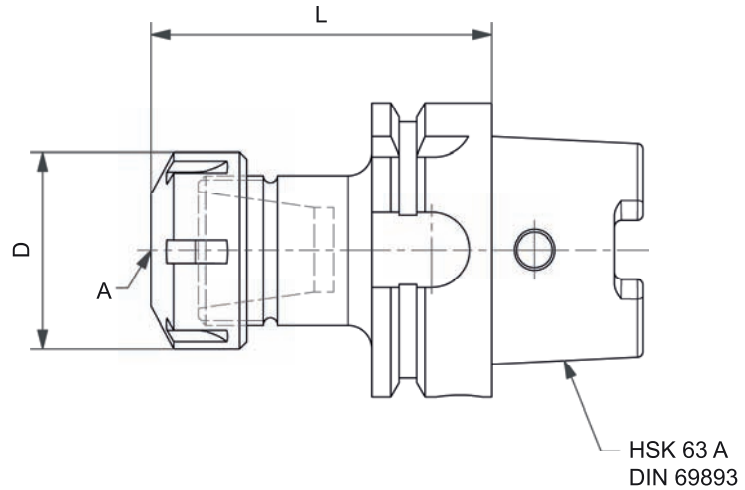
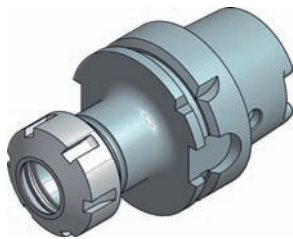

Schaft	D	A	L	Bestellnummer Order number
HSK63A	32	ER16	75	31.HSK63A16L75
HSK63A	32	ER16	100	31.HSK63A16L100
HSK63A	32	ER16	160	31.HSK63A16L160
HSK63A	42	ER25	75	31.HSK63A25L75
HSK63A	42	ER25	100	31.HSK63A25L100
HSK63A	42	ER25	160	31.HSK63A25L160
HSK63A	50	ER32	75	31.HSK63A32L75
HSK63A	50	ER32	100	31.HSK63A32L100
HSK63A	50	ER32	160	31.HSK63A32L160
HSK63A	63	ER40	90	31.HSK63A40L90
HSK63A	63	ER40	120	31.HSK63A40L120

Vollbohrerhalter Weldon Notch

U-drill holder

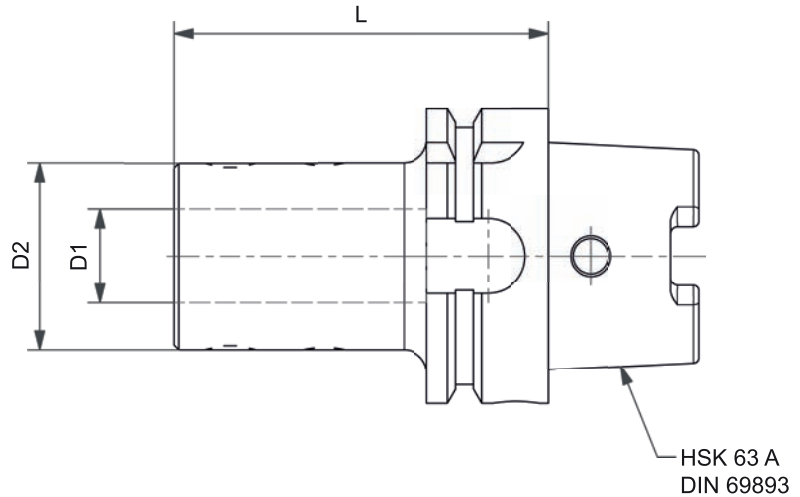
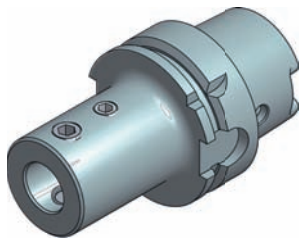

Schaft	D1	D2	L	Bestellnummer Order number
HSK63A	06	25	65	27.HSK63A06L65
HSK63A	08	28	65	27.HSK63A08L65
HSK63A	10	35	65	27.HSK63A10L65
HSK63A	12	42	80	27.HSK63A12L80
HSK63A	14	44	80	27.HSK63A14L80
HSK63A	16	48	80	27.HSK63A16L80
HSK63A	18	50	80	27.HSK63A18L80
HSK63A	20	52	80	27.HSK63A20L80
HSK63A	25	65	110	27.HSK63A25L110
HSK63A	32	72	110	27.HSK63A32L110

Vollbohrerhalter Whistle Notch

U-drill holder

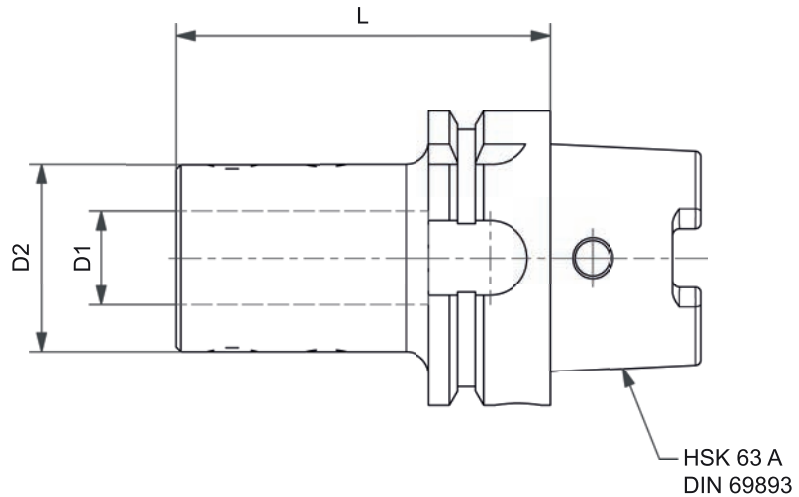
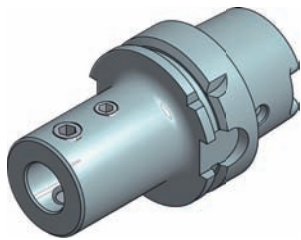

Schaft	D1	D2	L	Bestellnummer Order number
HSK63A	06	25	80	27.HSK63A06WNL80
HSK63A	08	28	80	27.HSK63A08WNL80
HSK63A	10	35	80	27.HSK63A10WNL80
HSK63A	12	42	90	27.HSK63A12WNL90
HSK63A	14	44	90	27.HSK63A14WNL90
HSK63A	16	48	100	27.HSK63A16WNL100
HSK63A	18	50	100	27.HSK63A18WNL100
HSK63A	20	52	100	27.HSK63A20WNL100
HSK63A	25	65	110	27.HSK63A25WNL110
HSK63A	32	72	110	27.HSK63A32WNL110

Bohrstangenhalter

Boring bar holder

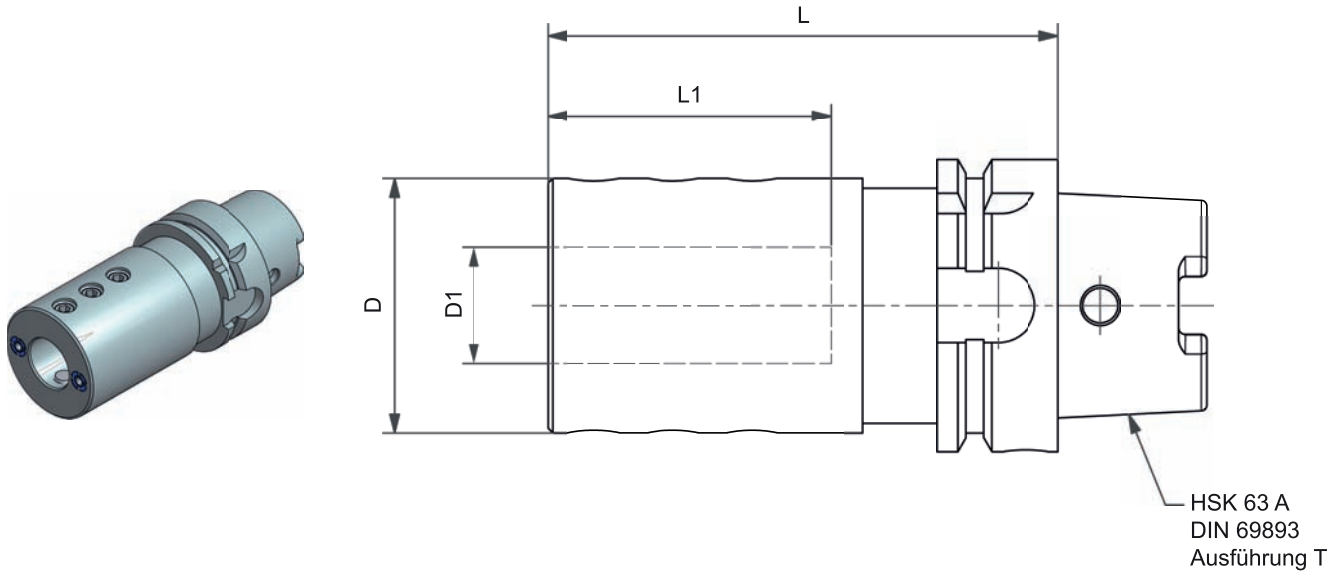

Schaft	D1	D	L1	L	Bestellnummer Order number
HSK63AT	06	55	61	100	19.HSK63AT06
HSK63AT	08	55	61	100	19.HSK63AT08
HSK63AT	10	55	61	100	19.HSK63AT10
HSK63AT	12	55	61	100	19.HSK63AT12
HSK63AT	16	55	61	100	19.HSK63AT16
HSK63AT	20	55	61	100	19.HSK63AT20
HSK63AT	25	55	61	110	19.HSK63AT25
HSK63AT	32	65	61	120	19.HSK63AT32
HSK63AT	40	62	75	125	19.HSK63AT40

Schrumpffutter

Shrink chuck

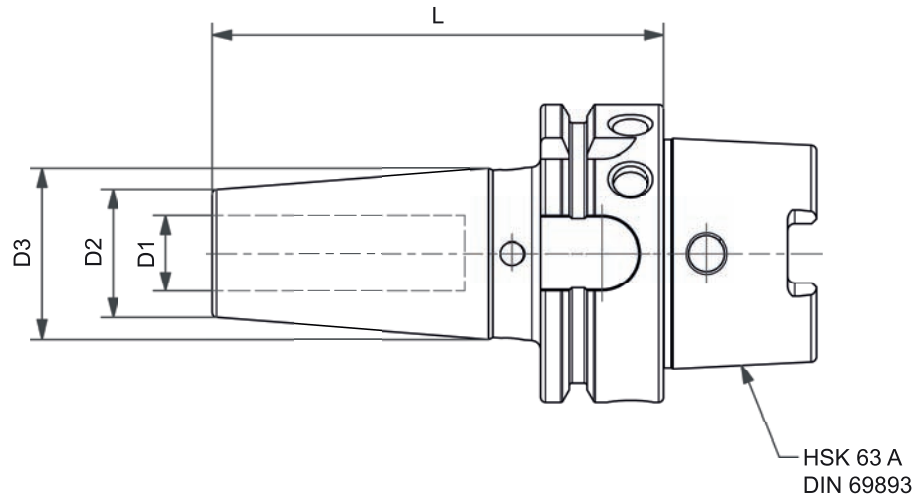
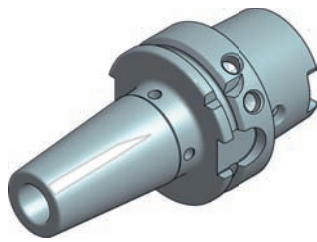

Schaft	D1	D2	D3	L	Bestellnummer Order number
HSK63A	08	21	30	80	27.HSK63A08L80SHR
HSK63A	10	24	33	85	27.HSK63A10L85SHR
HSK63A	12	24	34	90	27.HSK63A12L90SHR
HSK63A	14	27	37	90	27.HSK63A14L90SHR
HSK63A	16	27	38	95	27.HSK63A16L95SHR
HSK63A	18	33	44	95	27.HSK63A18L95SHR
HSK63A	20	33	45	100	27.HSK63A20L100SHR
HSK63A	25	44	53	115	27.HSK63A25L115SHR
HSK63A	32	44	53	120	27.HSK63A32L120SHR

Hydrodehnspannfutter

Hydraulik chuck

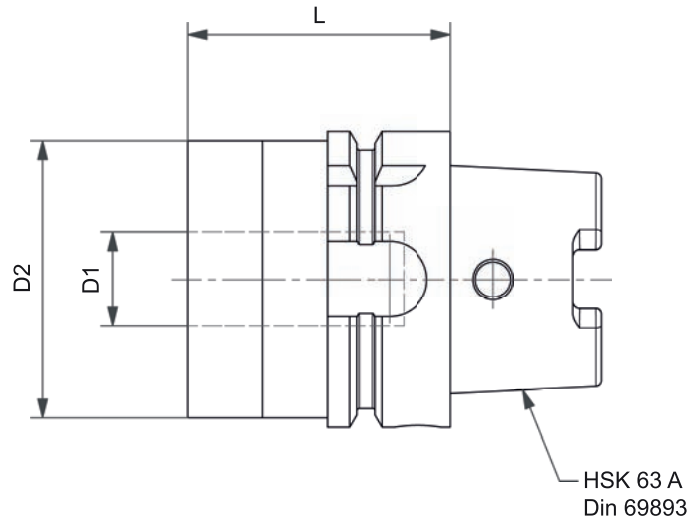
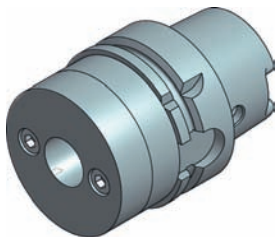

Schaft	D1	D2	L	Bestellnummer Order number
HSK63A	06	50	70	19.HSK63A06HYDL70
HSK63A	08	50	70	19.HSK63A08HYDL70
HSK63A	10	50	80	19.HSK63A10HYDL80
HSK63A	12	50	85	19.HSK63A12HYDL85
HSK63A	14	50	85	19.HSK63A14HYDL85
HSK63A	16	50	90	19.HSK63A16HYDL90
HSK63A	18	50	90	19.HSK63A18HYDL90
HSK63A	20	50	90	19.HSK63A20HYDL90
HSK63A	25	50	120	19.HSK63A25HYDL120
HSK63A	32	50	125	19.HSK63A32HYDL125

Axiale Messerkopfaufnahme

Axial face mill arbor

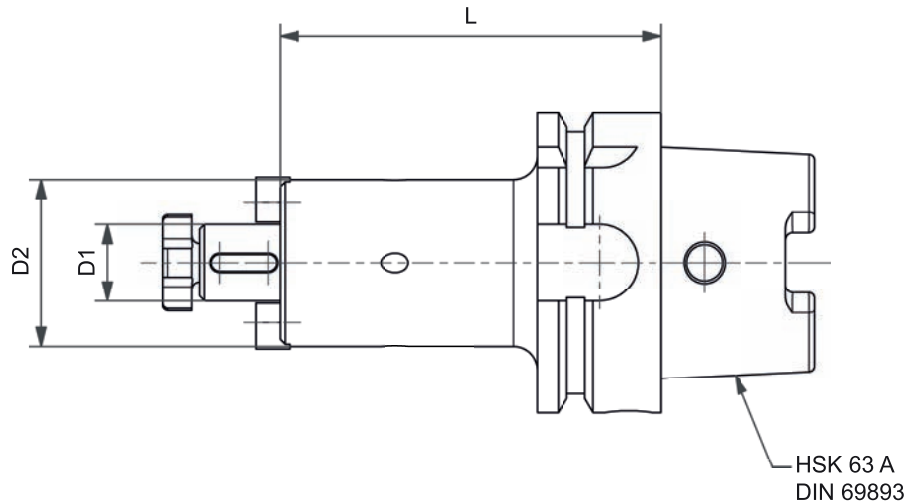
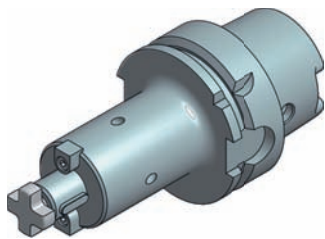

Schaft	D1	D2	L	Bestellnummer Order number
HSK63A	16	32	50	42.HSK63A16L50
HSK63A	16	32	100	42.HSK63A16L100
HSK63A	16	32	160	42.HSK63A16L160
HSK63A	22	40	50	42.HSK63A22L50
HSK63A	22	40	100	42.HSK63A22L100
HSK63A	22	40	160	42.HSK63A22L160
HSK63A	27	48	60	42.HSK63A27L60
HSK63A	27	48	100	42.HSK63A27L100
HSK63A	27	48	160	42.HSK63A27L160
HSK63A	32	58	60	42.HSK63A32L60
HSK63A	32	58	100	42.HSK63A32L100
HSK63A	32	58	160	42.HSK63A32L160

Morsekonus-Aufnahme

Morse cone adaptor

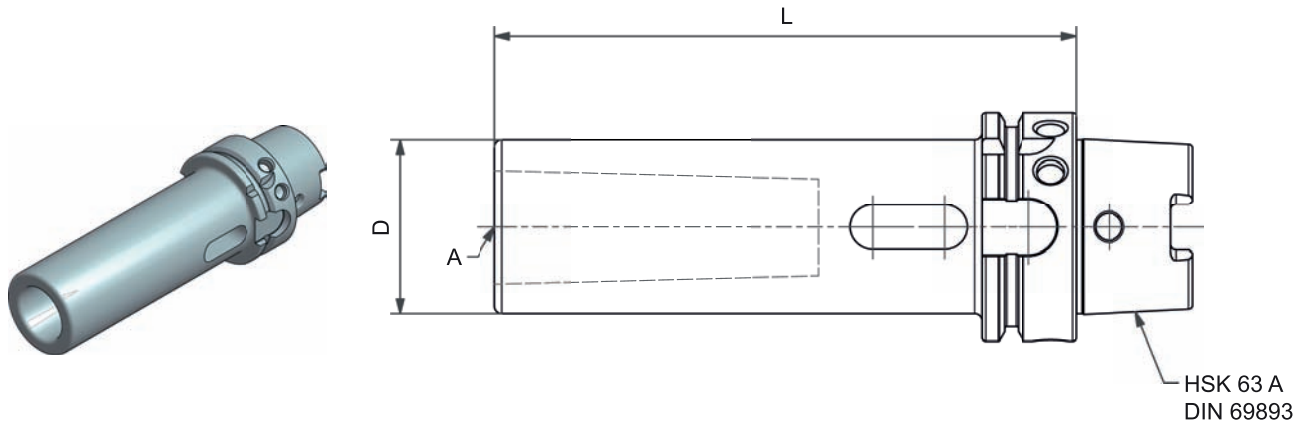

Schaft	D	A	L	Bestellnummer Order number
HSK63A	32	MK2	120	25.HSK63AMK2L120
HSK63A	40	MK3	140	25.HSK63AMK3L140
HSK63A	48	MK4	160	25.HSK63AMK4L160

Bohrfutter

Drill chuck

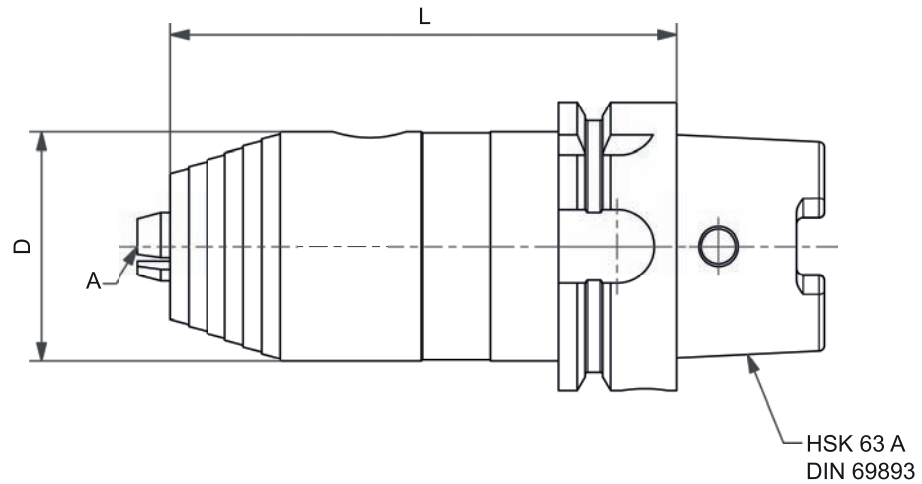
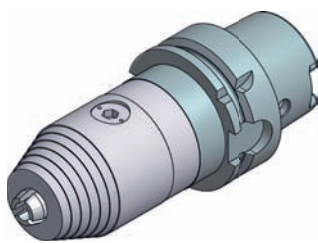

Schaft	D	A	L	Bestellnummer Order number
HSK63A	Ø 50	0,5 -13 mm	104	25.550- HSK63A13L104
HSK63A	Ø 57	2,5 - 16 mm	109	25.550- HSK63A16L109

Einrichtdorn

Setting holder

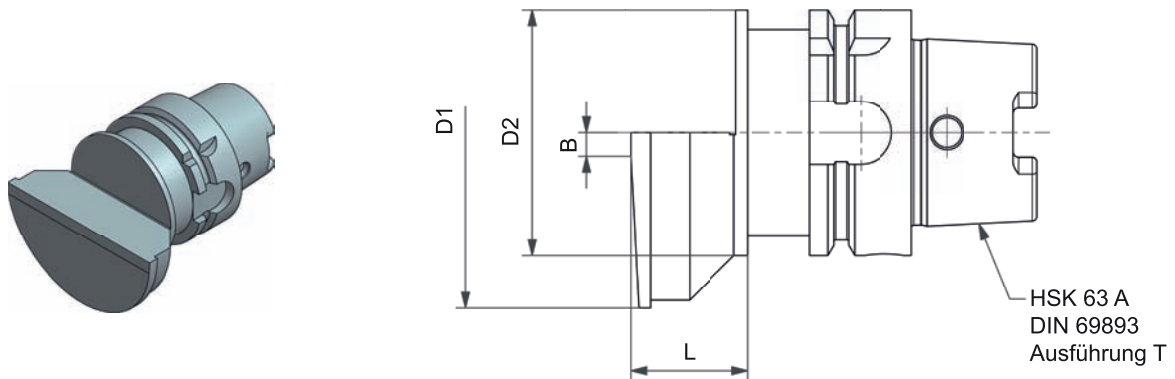

Schaft	D1	D2	B	L	Bestellnummer Order number
HSK63AT	90	63	6	30	EHSK63AT.90.65

Prüfdorn

Test mandrel

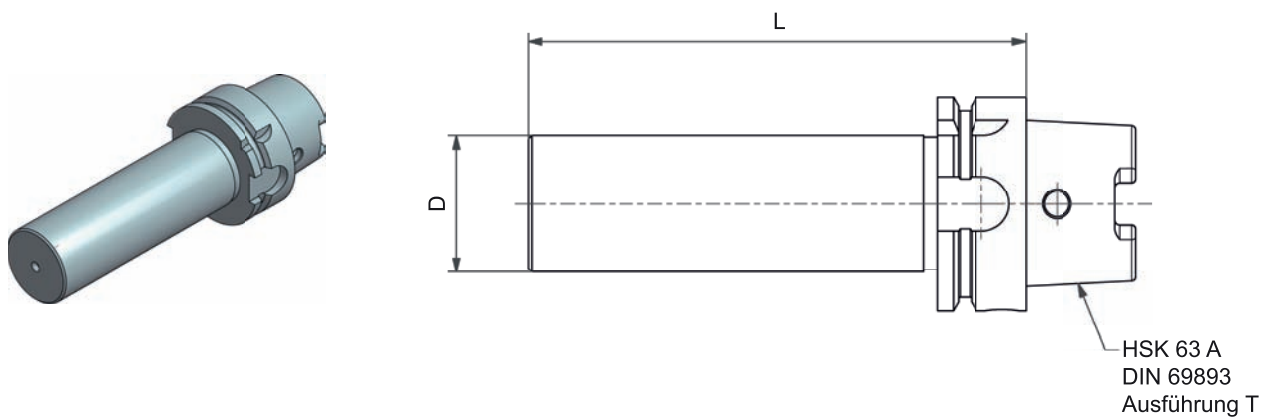

Schaft	D	L	Bestellnummer Order number
HSK63A	41	346	PHSK63A.40.346

Rohling

Blank

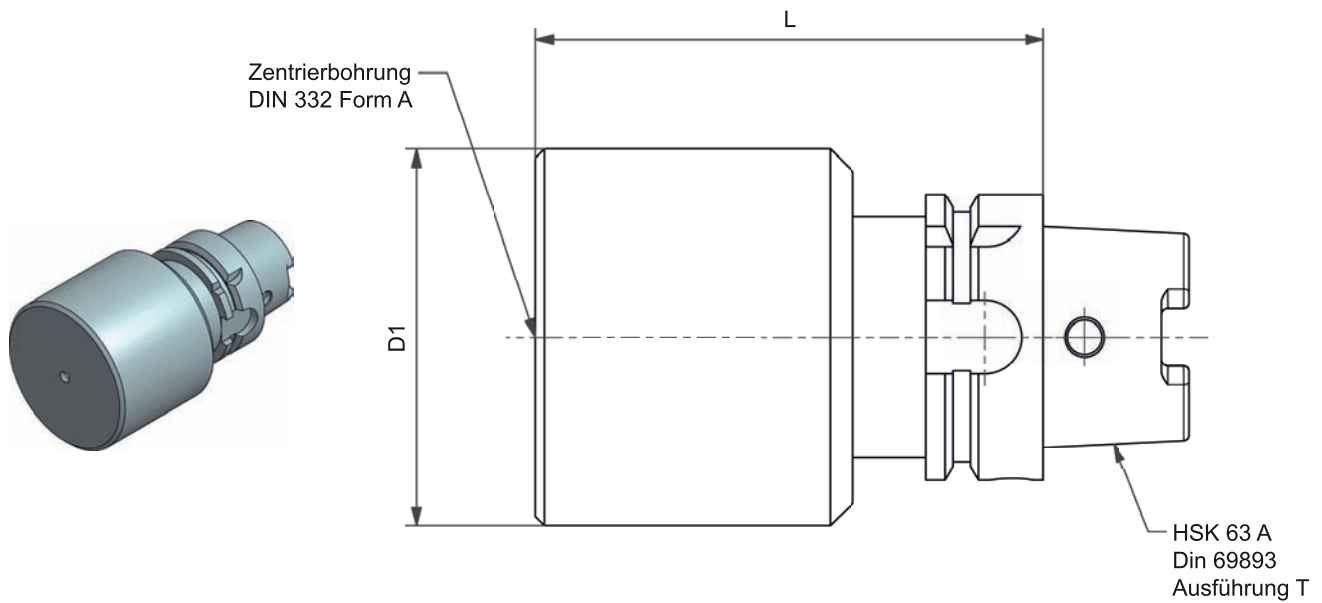

Schaft	D1	L	Bestellnummer Order number
HSK63AT	63	70	RHSK63AT.063.070
HSK63AT	83	200	RHSK63AT.083.200
HSK63AT	100	127	RHSK63AT.100.127

weitere Abmessungen kurzfristig auf Anfrage möglich
other measures are available on request at short notice

Vierkant Längsaufnahme

Turning toolholder for square tool

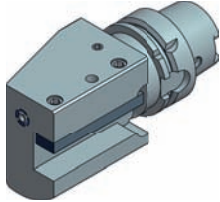

Schaft	Werkzeugtyp Type	Stahlhöhe Heigth	Länge Length	Bestellnummer Order number
HSK63AT	Vierkant Längsaufnahme rechts Turning toolholder for square tool right hand	20	127	1.HSK63AT20x13

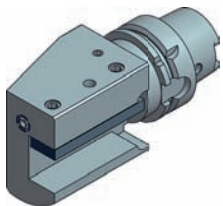

Schaft	Werkzeugtyp Type	Stahlhöhe Heigth	Länge Length	Bestellnummer Order number
HSK63AT	Vierkant Längsaufnahme rechts Turning toolholder for square tool right hand	25	127	1.HSK63AT25x8

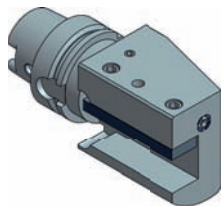

Schaft	Werkzeugtyp Type	Stahlhöhe Heigth	Länge Length	Bestellnummer Order number
HSK63AT	Vierkant Längsaufnahme links Turning toolholder for square tool left hand	25	127	4.HSK63AT25x8

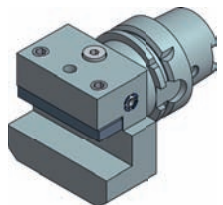

Schaft	Werkzeugtyp Type	Stahlhöhe Heigth	Länge Length	Bestellnummer Order number
HSK63AT	Vierkant Queraufnahme rechts Turning tool right hand	25	86	5.HSK63AT25

Vierkant Längsaufnahme Ausführung unter 45° Turning toolholder under 45°

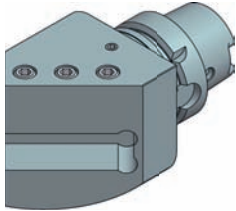

Schaft	Werkzeugtyp Type	Stahlhöhe Height	Länge Length	Bestellnummer Order number
HSK63AT	Vierkant Längsaufnahme rechts Turning toolholder for square tool right hand	25	110	1.HSK63AT25-45°

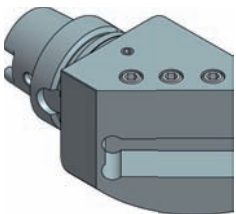

Schaft	Werkzeugtyp Type	Stahlhöhe Height	Länge Length	Bestellnummer Order number
HSK63AT	Vierkant Längsaufnahme links Turning toolholder for square tool left hand	25	110	4.HSK63AT25-45°

Vierkant Mehrfachaufnahme

Multipurpose holder for square tool

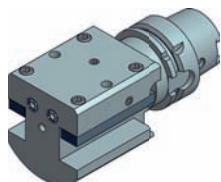

Schaft	Werkzeugtyp Type	Stahlhöhe Height	Länge Length	Bestellnummer Order number
HSK63AT	Vierkant Mehrfachaufnahme Multipurpose square toolholder	20	127	15.HSK63AT20- 2FACH

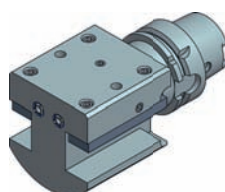

Schaft	Werkzeugtyp Type	Stahlhöhe Height	Länge Length	Bestellnummer Order number
HSK63AT	Vierkant Mehrfachaufnahme Multipurpose square toolholder	25	127	15.HSK63AT25- 2FACH

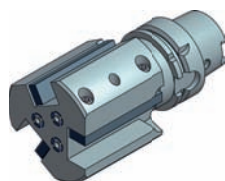

Schaft	Werkzeugtyp Type	Stahlhöhe Height	Länge Length	Bestellnummer Order number
HSK63AT	Vierkant Mehrfachaufnahme Multipurpose square toolholder	20	127	15.HSK63AT20- 3FACH

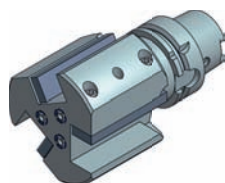

Schaft	Werkzeugtyp Type	Stahlhöhe Height	Länge Length	Bestellnummer Order number
HSK63AT	Vierkant Mehrfachaufnahme Multipurpose square toolholder	25	127	15.HSK63AT25- 3FACH

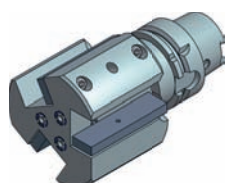

Schaft	Werkzeugtyp Type	Stahlhöhe Height	Länge Length	Bestellnummer Order number
HSK63AT	Vierkant Mehrfachaufnahme Multipurpose square toolholder	25	127	16.HSK63AT25- 3FACH

Abstechhalter

Infeed toolholder

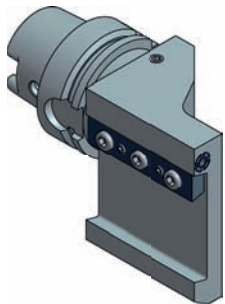

Schaft	Werkzeugtyp Type	Schwerthöhe Swivel heigth	Bestellnummer Order number
HSK63AT	Abstechhalter, links Infeed toolholder left hand	32	32.HSK63AT32L

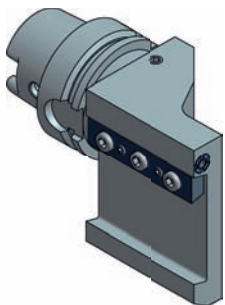

Schaft	Werkzeugtyp Type	Schwerthöhe Swivel heigth	Bestellnummer Order number
HSK63AT	Abstechhalter, links Infeed toolholder left hand	52	32.HSK63ATSH52L

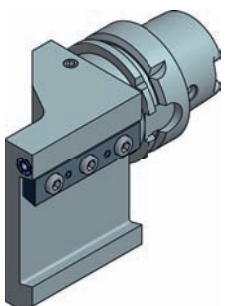

Schaft	Werkzeugtyp Type	Schwerthöhe Swivel heigth	Bestellnummer Order number
HSK63AT	Abstechhalter, rechts Infeed toolholder right hand	52	32.HSK63ATSH52R

Werkzeuge mit Plattensitz

Toolholders with insert pocket

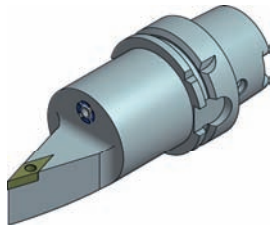

Schaft	Werkzeugtyp Type	Bestellnummer Order number
HSK63AT	Klemmhalter für Wendeschneidplatten Turning toolholder	1.HSK63ATSVVB- H16

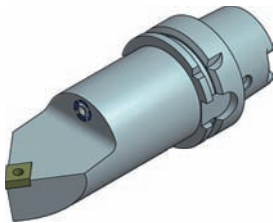

Schaft	Werkzeugtyp Type	Bestellnummer Order number
HSK63AT	Klemmhalter für Wendeschneidplatten Turning toolholder	1.HSK63ATPCMN -L12

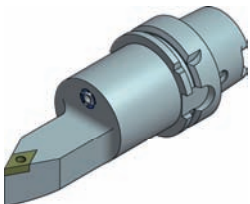

Schaft	Werkzeugtyp Type	Bestellnummer Order number
HSK63AT	Klemmhalter für Wendeschneidplatten Turning toolholder	1.HSK63ATPDNN -L15

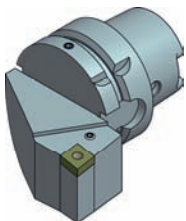

Schaft	Werkzeugtyp Type	Bestellnummer Order number
HSK63AT	Klemmhalter für Wendeschneidplatten rechts Turning toolholder right hand	5.HSK63ATPCLN- DX12

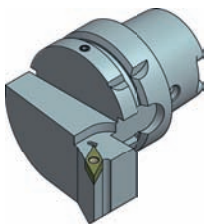

Schaft	Werkzeugtyp Type	Bestellnummer Order number
HSK63AT	Klemmhalter für Wendeschneidplatten rechts Turning toolholder right hand	5.HSK63ATSVPB- DX16

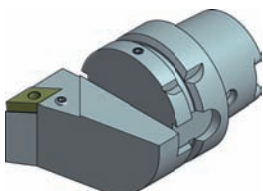

Schaft	Werkzeugtyp Type	Bestellnummer Order number
HSK63AT	Klemmhalter für Wendeschneidplatten links Turning toolholder left hand	8.HSK63ATPDJN- DX15

Wir fertigen in Sondermaßen Klemmdrehhalter für sämtliche Wendepplatten

We produce toolholders for almost all cutting inserts

Sonderhalter

Special toolholder

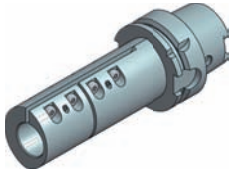

geschlitzter
Bohrstangenhalter
Slotted boring bar holder

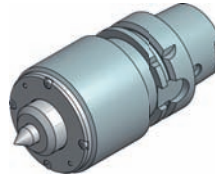

mitlaufende
Zentrierspitze
live centre

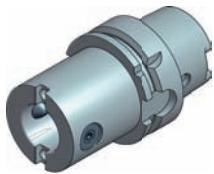

Ausgleichhalter
mit ABS-Aufnahme
Adaptor to ABS



Pendelhalter
Floating holder

weitere Sonderhalter auf Anfrage verfügbar
other special toolholders are available on request



Capto-Werkzeuge

Capto tools

Porte-outils Capto

Spannzangenaufnahme

Collet chuck

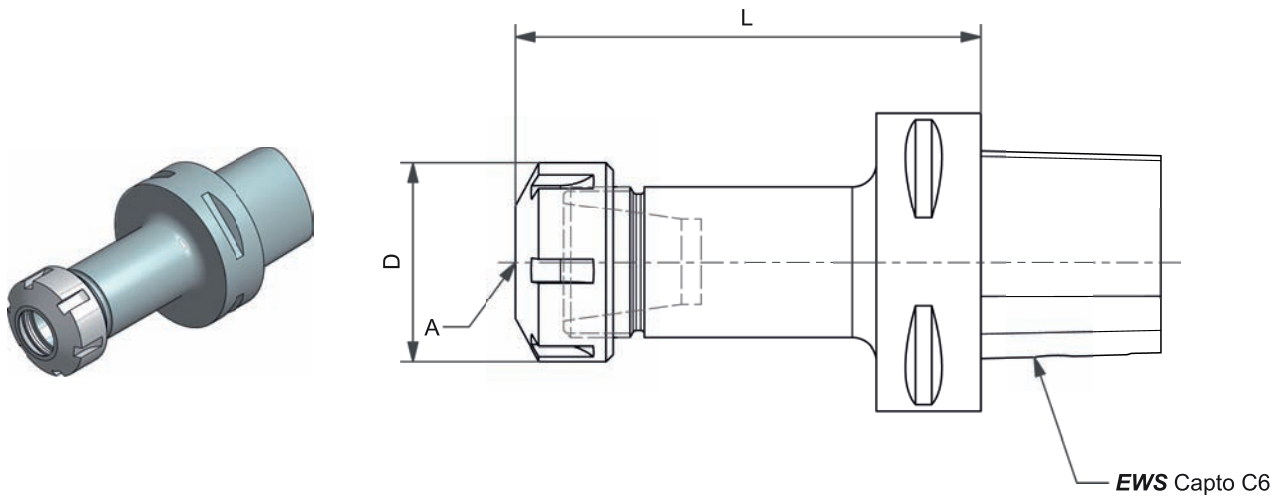

EWS Capto™	D	A	L	Bestellnummer Order number
C6	28	ER16	60	31.C616L60
C6	28	ER16	100	31.C616L100
C6	34	ER20	60	31.C620L60
C6	34	ER20	100	31.C620L100
C6	42	ER25	60	31.C625L60
C6	42	ER25	100	31.C625L100
C6	50	ER32	60	31.C632L60
C6	50	ER32	100	31.C632L100
C6	63	ER40	65	31.C640L65
C6	63	ER40	100	31.C640L100

Vollbohrerhalter, Weldon + Whistle Notch

U-drill holder

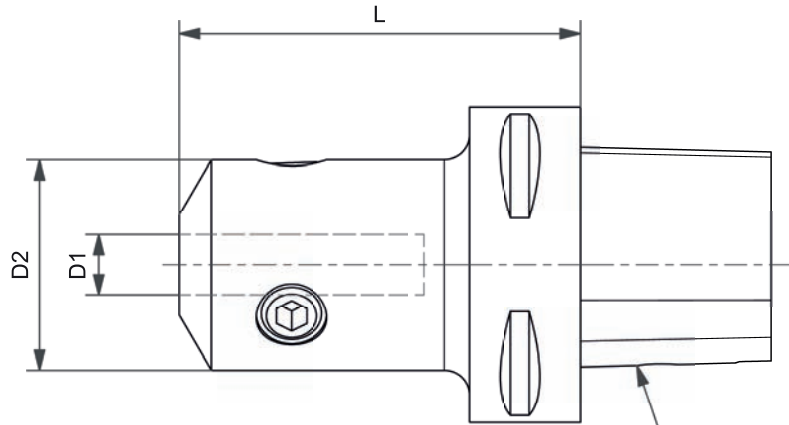
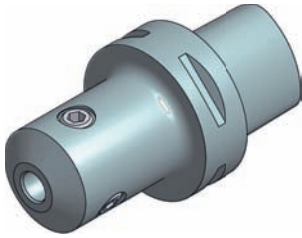

EWS Capto C6

EWS Capto™	D1	D2	L	Bestellnummer Order number
C6	06	25	80	27.C606WNL80
C6	08	28	80	27.C608WNL80
C6	10	35	80	27.C610WNL80
C6	12	42	80	27.C612WNL80
C6	14	42	80	27.C614WNL80
C6	16	48	80	27.C616WNL80
C6	18	48	80	27.C618WNL80
C6	20	52	80	27.C620WNL80
C6	25	65	90	27.C625WNL90
C6	32	72	90	27.C632WNL90
C6	40	80	95	27.C640WNL95

Bohrstangenhalter

Boring bar holder

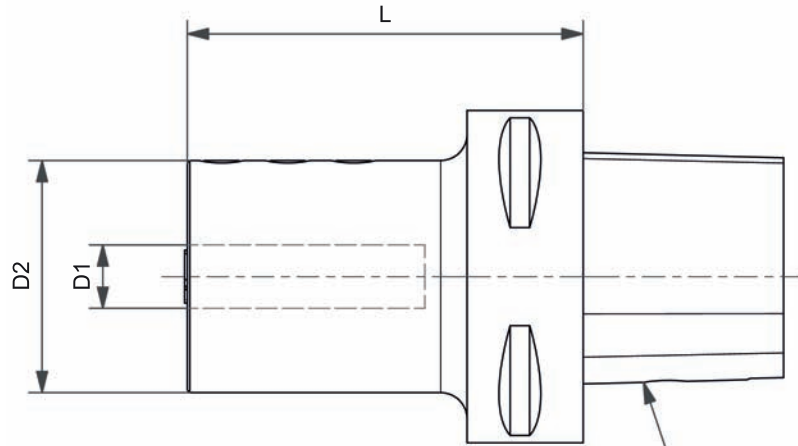
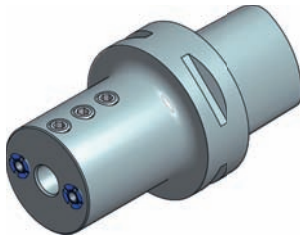

interne und externe Kühlmittelzufuhr
internal and external coolant

EWS Capto C6

EWS Capto™	D1	D2	L	Bestellnummer Order number
C6	06	44	75	19.C606L75
C6	08	44	75	19.C608L75
C6	10	44	75	19.C610L75
C6	12	44	75	19.C612L75
C6	16	44	75	19.C616L75
C6	20	50	75	19.C620L75
C6	25	55	75	19.C625L75
C6	32	72	75	19.C632L75
C6	40	70	85	19.C640L85

Schrumpffutter

Shrink chuck

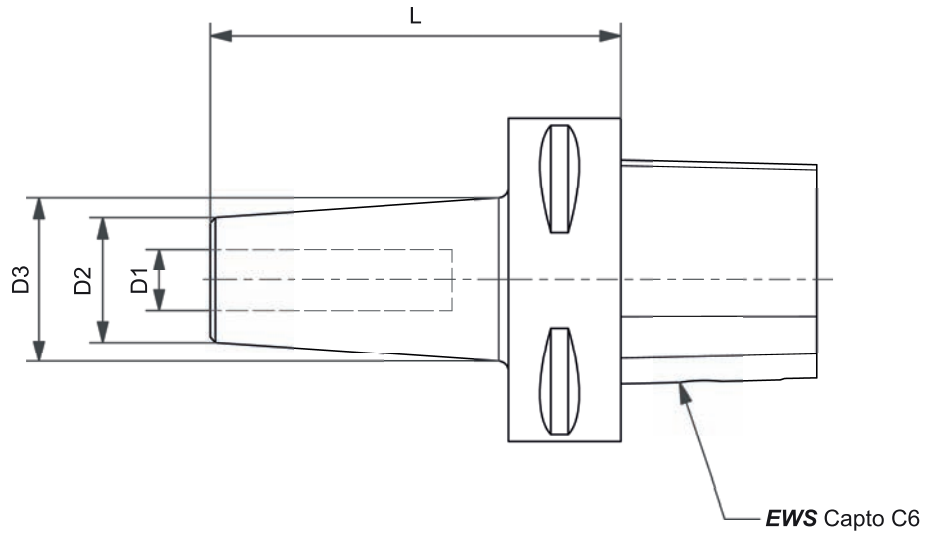
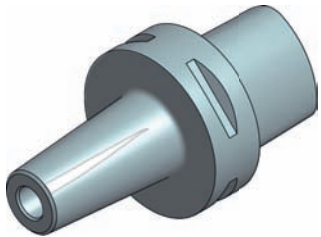

EWS Capto™	D1	D2	D3	L	Bestellnummer Order number
C6	10	24	32	80	27.C610L80SHR
C6	12	24	32	80	27.C612L80SHR
C6	14	27	34	85	27.C614L85SHR
C6	18	33	42	85	27.C618L85SHR
C6	20	33	42	85	27.C620L85SHR
C6	25	44	52,5	90	27.C625L90SHR
C6	32	44	52,5	95	27.C632L95SHR

Hydrodehnspannfutter

Hydraulik chuck

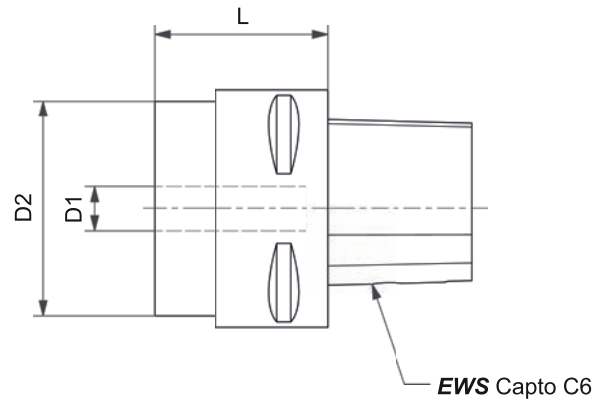
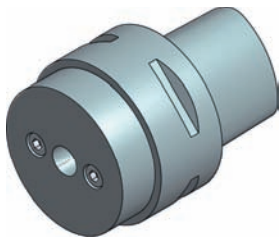

EWS Capto™	D1	D2	L	Bestellnummer Order number
C6	06	50	72	19.C606HYDL72
C6	08	50	72	19.C608HYDL72
C6	10	50	82	19.C610HYDL82
C6	12	50	87	19.C612HYDL87
C6	14	50	87	19.C614HYDL87
C6	16	50	92	19.C616HYDL92
C6	18	50	92	19.C618HYDL92
C6	20	50	97	19.C620HYDL97
C6	25	50	102	19.C625HYDL102
C6	32	50	110	19.C632HYDL110

Axiale Messerkopfaufnahme

Axial face mill arbor

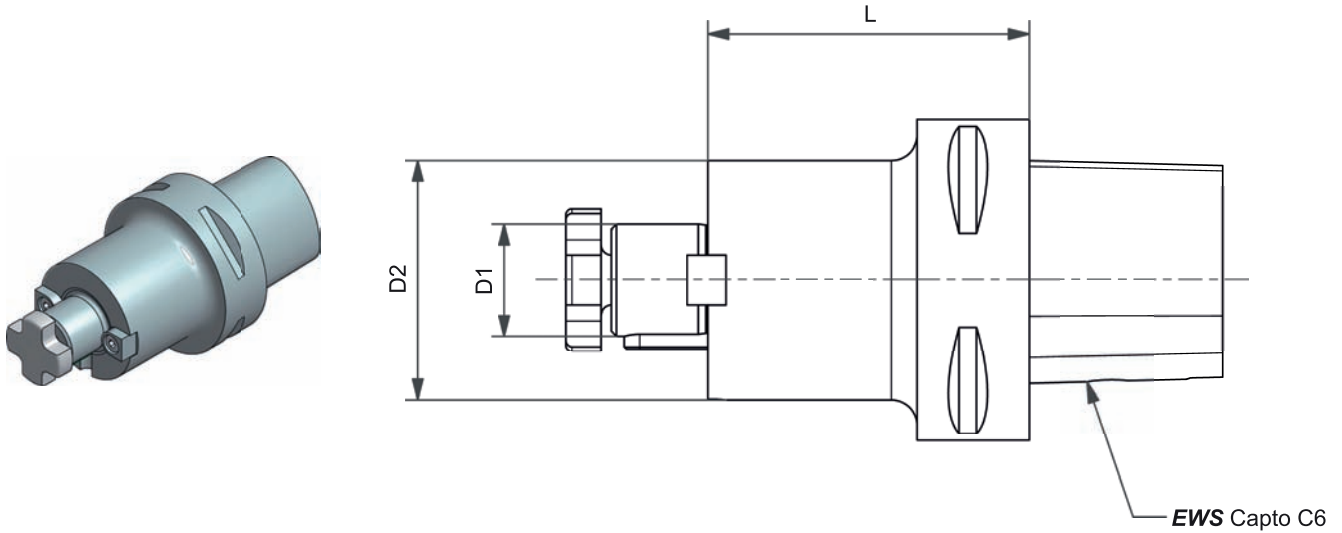

EWS Capto™	D1	D2	L	Bestellnummer Order number
C6	16	37	63	42.C616L63
C6	22	47	28	42.C622L28
C6	22	47	63	42.C622L63
C6	27	58	28	42.C627L28
C6	27	58	63	42.C627L63
C6	32	63	22	42.C632L22
C6	32	63	63	42.C632L63
C6	32	63	86	42.C632L86

Morsekonus-Aufnahme

Morse cone adaptor

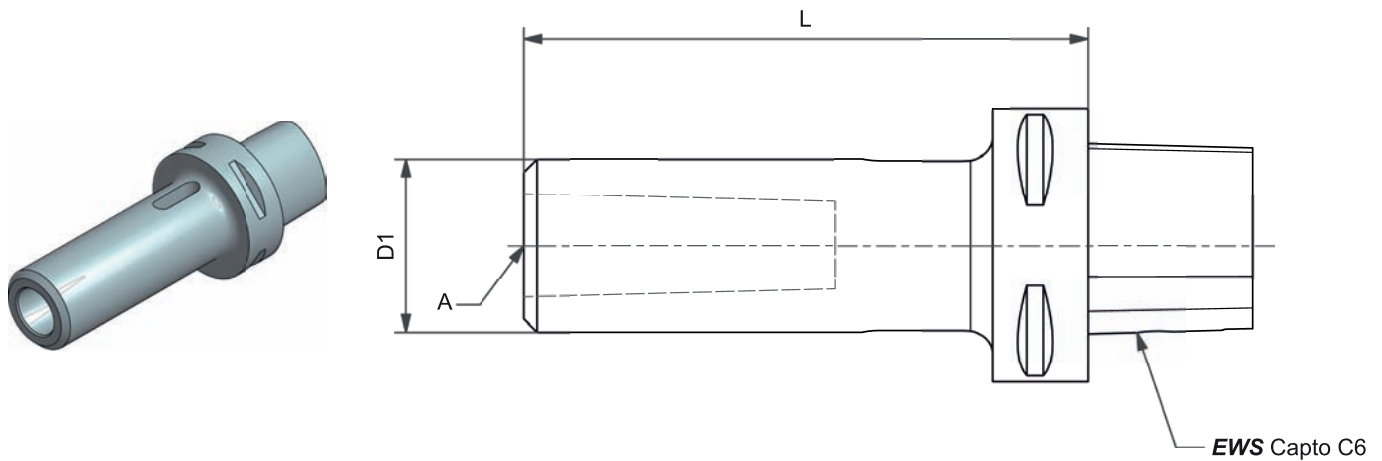

EWS Capto™	D1	A	L	Bestellnummer Order number
C6	32	MK2	110	25.C6MK2L110
C6	40	MK3	130	25.C6MK3L130
C6	52	MK4	150	25.C6MK4L150

Bohrfutter

Drill chuck

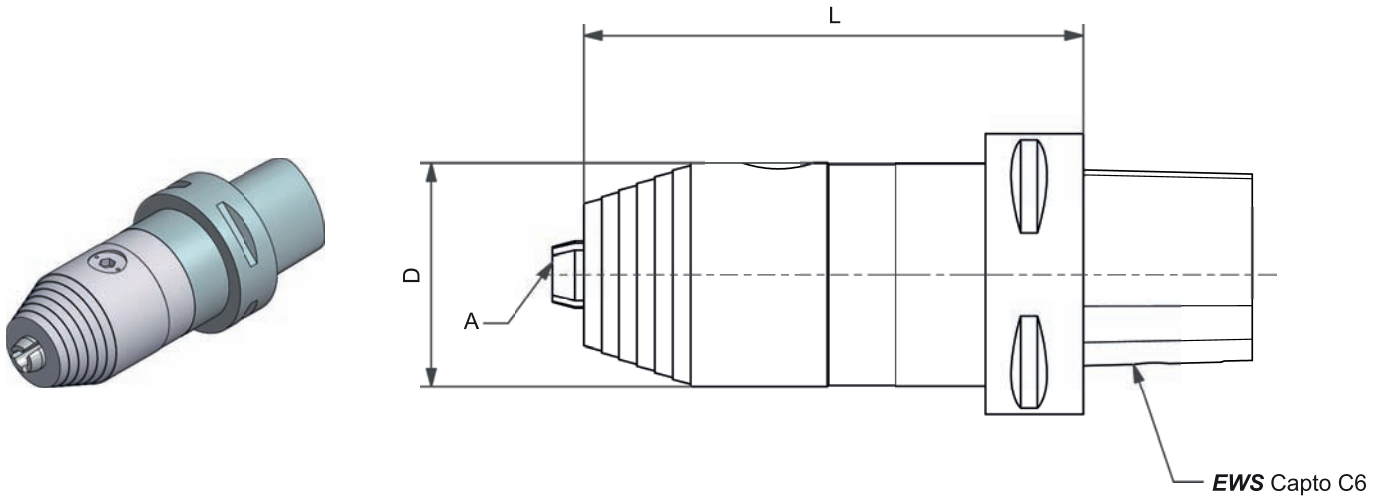

EWS Capto™	D	A	L	Bestellnummer Order number
C6	Ø 50	0,5 – 13 mm	112	25.550-C613L112
C6	Ø 57	3 – 16 mm	112	25.550-C616L112

Einrichtdorn

Setting holder

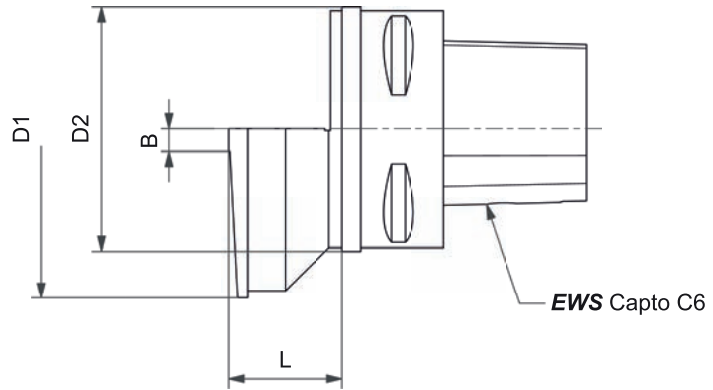
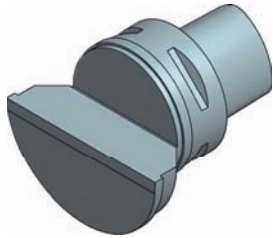

EWS Capto™	Werkzeugtyp Type	D1	D2	B	L	Bestellnummer Order number
C6	Einrichtdorn Setting holder	90	65	6	30	EC6.90.65

Prüfdorn

Test mandrel

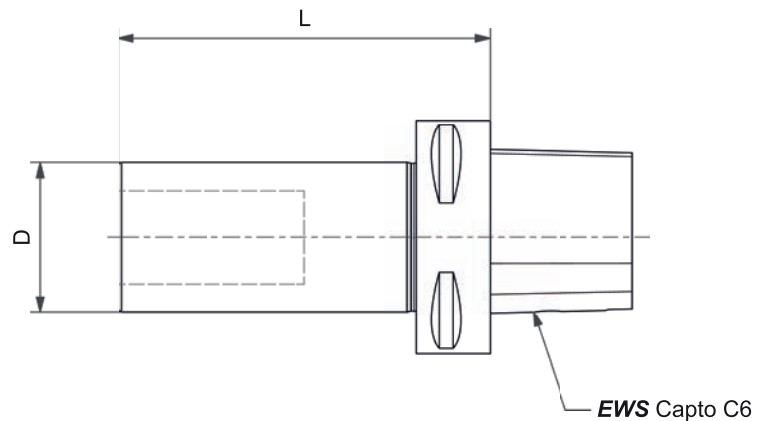
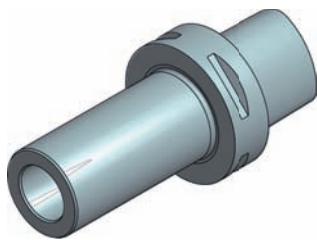

EWS Capto™	D	L	Bestellnummer Order number
C6	40	300	PC6.40.300
C6	32	200	PC6.32.200

Rohling

Blank

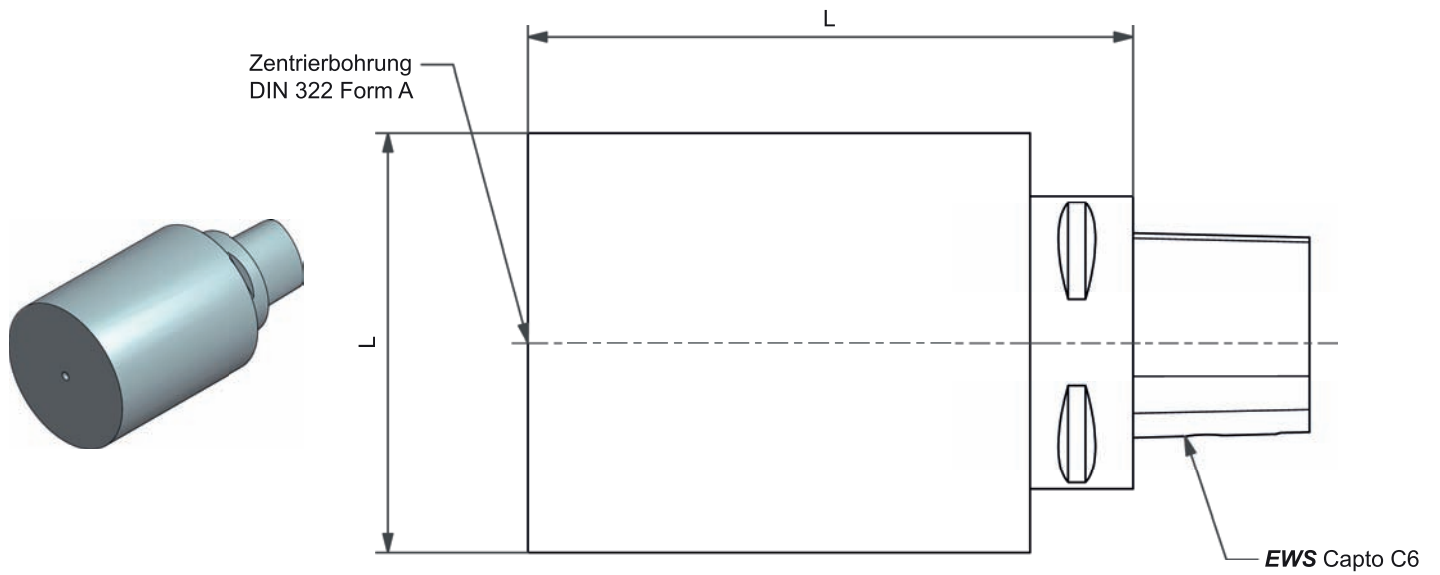

EWS Capto™	D	L	Bestellnummer Order number
C6	110	120	RC6B110L120
C6	63,5	180	RC6B063,5L180

weitere Abmessungen kurzfristig auf Anfrage möglich
other measures are available on request at short notice

Vierkant Längsaufnahme

Turning toolholder for square tool

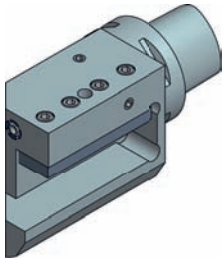

EWS Capto™	Werkzeugtyp Type	Stahlhöhe Heigth	Länge Length	Bestellnummer Order number
C6	Vierkant Längsaufnahme rechts Turning toolholder for square tool right hand	25	130	1.C625L130

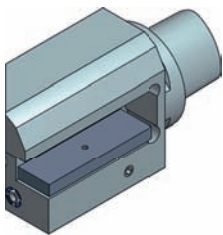

EWS Capto™	Werkzeugtyp Type	Stahlhöhe Heigth	Länge Length	Bestellnummer Order number
C6	Vierkant Längsaufnahme rechts, überkopf Turning toolholder for square tool right hand, overhead	25	130	2.C625L130

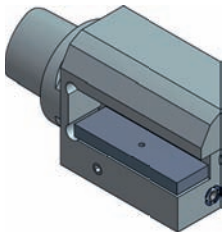

EWS Capto™	Werkzeugtyp Type	Stahlhöhe Heigth	Länge Length	Bestellnummer Order number
C6	Vierkant Längsaufnahme links, überkopf Turning toolholder for square tool left hand, overhead	25	130	3.C625L130

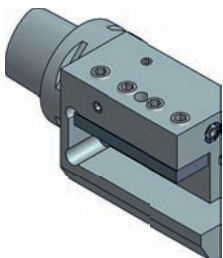

EWS Capto™	Werkzeugtyp Type	Stahlhöhe Heigth	Länge Length	Bestellnummer Order number
C6	Vierkant Längsaufnahme links Turning toolholder for square tool left hand	25	130	4.C625L130

Vierkant Längsaufnahme Ausführung unter 45°

Turning toolholder under 45°

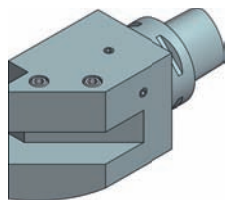

EWS Capto™	Werkzeugtyp Type	Stahlhöhe Height	Länge Length	Bestellnummer Order number
C6	Vierkant Längsaufnahme rechts Turning toolholder for square tool right hand	25	130	1.C625G45L130

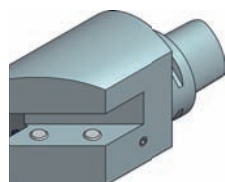

EWS Capto™	Werkzeugtyp Type	Stahlhöhe Height	Länge Length	Bestellnummer Order number
C6	Vierkant Längsaufnahme rechts, überkopf Turning toolholder for square tool right hand, overhead	25	130	2.C625G45L130

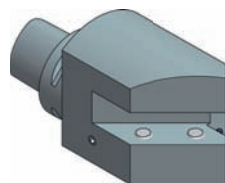

EWS Capto™	Werkzeugtyp Type	Stahlhöhe Height	Länge Length	Bestellnummer Order number
C6	Vierkant Längsaufnahme links, überkopf Turning toolholder for square tool left hand, overhead	25	130	3.C625G45L130

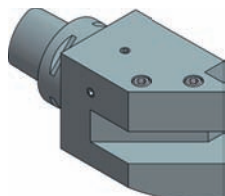

EWS Capto™	Werkzeugtyp Type	Stahlhöhe Height	Länge Length	Bestellnummer Order number
C6	Vierkant Längsaufnahme links Turning toolholder for square tool left hand	25	130	4.C625G45L130

Vierkant Mehrfachaufnahme

Multi purpose holder for square tool

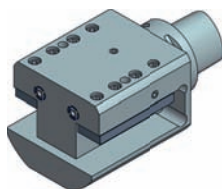

EWS Capto™	Werkzeugtyp Type	Stahlhöhe Height	Länge Length	Bestellnummer Order number
C6	Vierkant Mehrfachaufnahme Multi purpose square toolholder	25	130	15.C625L130- 2FACH

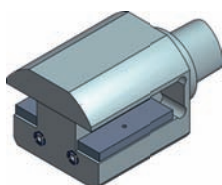

EWS Capto™	Werkzeugtyp Type	Stahlhöhe Height	Länge Length	Bestellnummer Order number
C6	Vierkant Mehrfachaufnahme überkopf Multi purpose square toolholder, overhead	25	130	16.C625L130- 2FACH

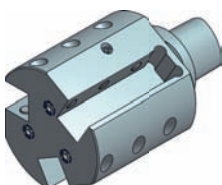

EWS Capto™	Werkzeugtyp Type	Stahlhöhe Height	Länge Length	Bestellnummer Order number
C6	Vierkant Mehrfachaufnahme Multi purpose square toolholder	25	130	15.C625L130- 3FACH

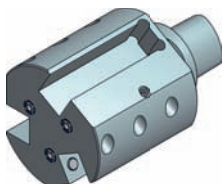

EWS Capto™	Werkzeugtyp Type	Stahlhöhe Height	Länge Length	Bestellnummer Order number
C6	Vierkant Mehrfachaufnahme überkopf Multi purpose square toolholder, overhead	25	130	16.C625L130- 3FACH

Abstechhalter

Infeed toolholder

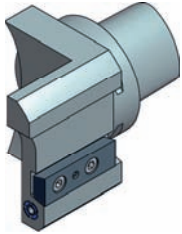

EWS Capto™	Werkzeugtyp Type	Schwerthöhe Swivel heigth	Bestellnummer Order number
C6	Abstechhalter, überkopf, rechts Infeed toolholder right hand, overhead	32	32.C632ÜKR

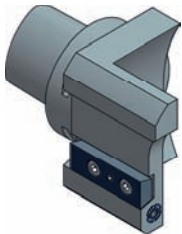

EWS Capto™	Werkzeugtyp Type	Schwerthöhe Swivel heigth	Bestellnummer Order number
C6	Abstechhalter, überkopf, links Infeed toolholder left hand, overhead	32	32.C632ÜKL

Sonderhalter

Special toolholder

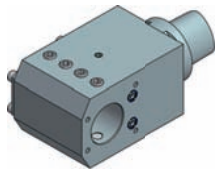

Kombihalter quer
für Innen- und
Aussenkühlung
Combi holder

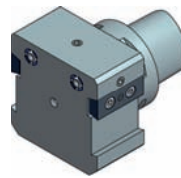

Abstechhalter
mit doppelseitiger
Ausführung
Double cut-off holder



Ausgleichhalter
mit ABS-Aufnahme
Adaptor to ABS

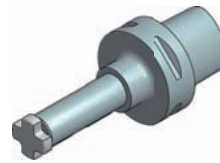

Axial Fräsdornhalter
lange Ausführung
Axial milling arbor long
version



Ausgleichhalter
mit EWS-Varia
Adaptor to EWS-Varia



Pendelhalter
Floating holder

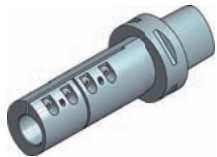

geschlitzter
Bohrstangenhalter
Slotted boring bar holder

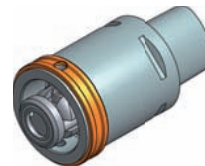

Ausgleichhalter
mit HSK Aufnahme
Adaptor to HSK

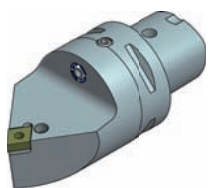

Werkzeug für die
Außenbearbeitung
OD tool holder

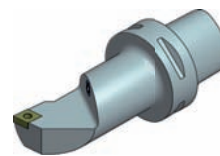

Bohrstangenhalter
Boring bar holder

weitere Sonderhalter auf Anfrage verfügbar
other special toolholders are available on request



EWS Varia

*Axial
Bohr- u. Fräskopf*
EWS-Varia

*Axial drilling
and milling head*
EWS-Varia

*Tête de perçage
et fraissage, axial*
EWS-Varia

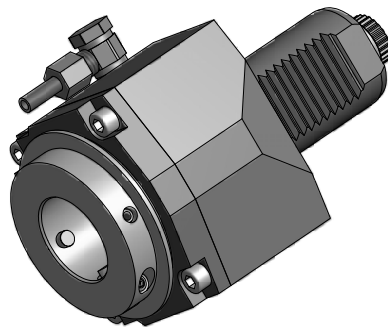
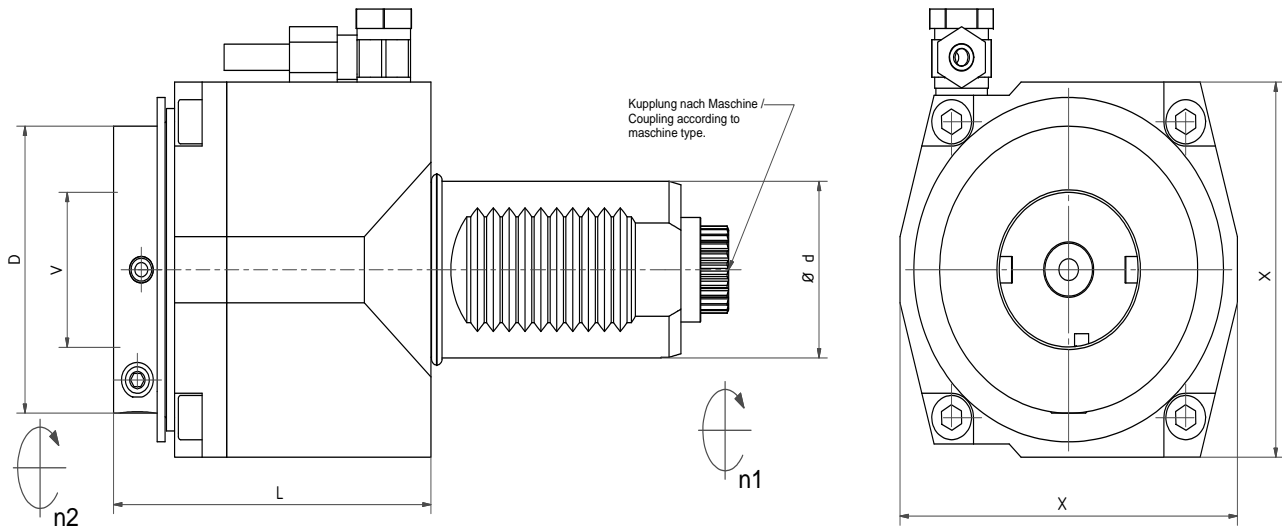

Nr. / No.	d	V	L	Ø D	X	n _{max}	T _{max}
40.25V3...	25	V3	56	58	68	6000 1/min	25 Nm
40.30V3...	30	V3	56	55	68	6000 1/min	25 Nm
40.40V4...	40	V4	80	65	85	6000 1/min	50 Nm
40.50V5...	50	V5	100,5	96	96	4000 1/min	100 Nm

5482	Sauter - Revolver / turret DIN 5482
1809	Duplomatic- Revolver / turret DIN 1809
TOEM	Baruffaldi Revolver / turret
CTX / 5480	Sauter - Revolver / turret
Bsp. / Exp. : 40.30V3CTX	

*Radial
Bohr- u. Fräskopf*
EWS-Varia

*Radial drilling
and milling head*
EWS-Varia

*Tête de perçage
et fraissage, radial*
EWS-Varia

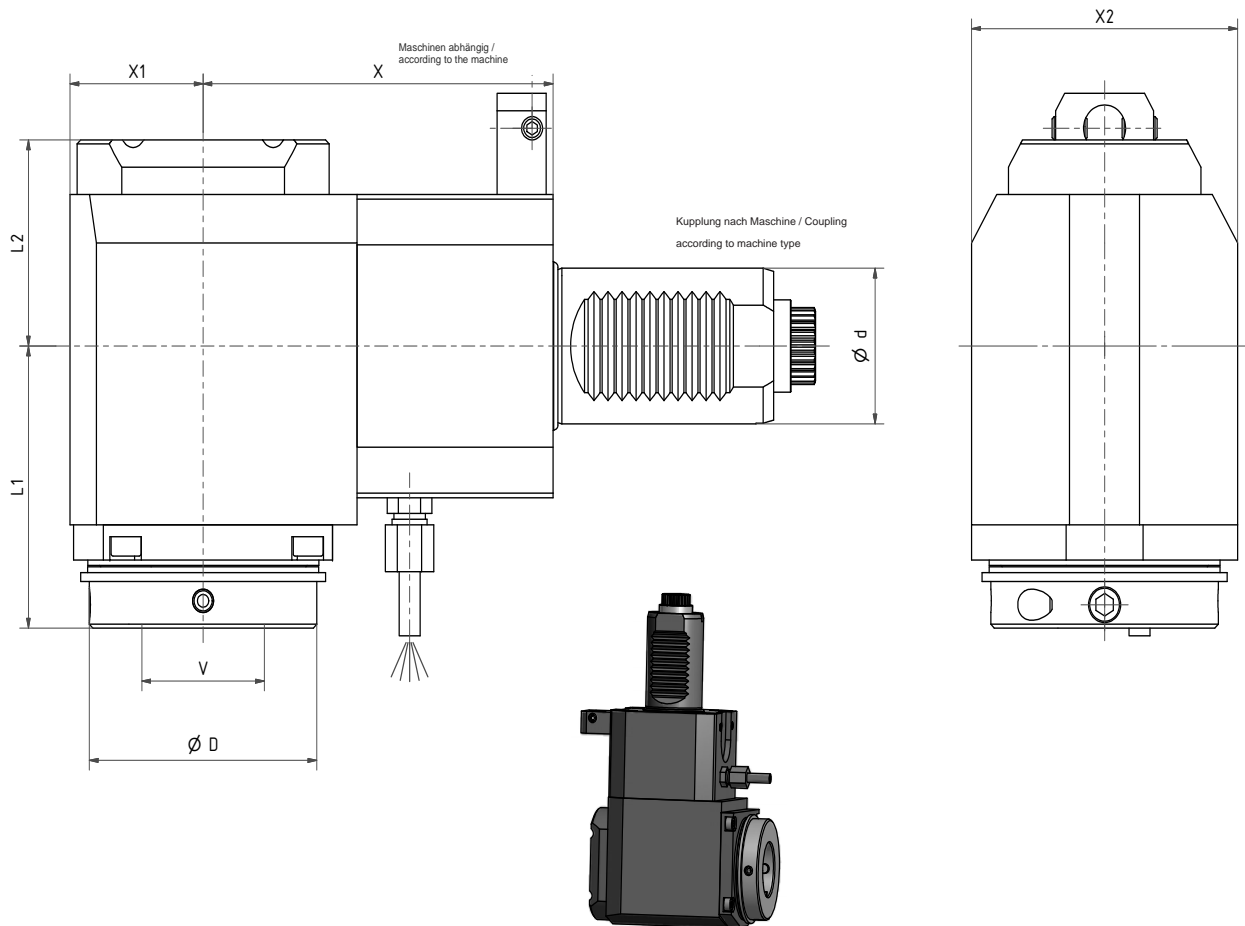

Nr. / No.	d	V	L1	L2	Ø D	X1	X2	n _{max}	T _{max}
60.25V3...	25	V3	65,5	41	55	34	68	6000 1/min	25 Nm
60.30V3...	30	V3	65,5	41	55	34	68	6000 1/min	25 Nm
60.40V4...	40	V4	72,5	53	65	38	76	5000 1/min	50 Nm
60.50V5...	50	V5	90	60	89	52	104	4000 1/min	100 Nm

5482	Sauter - Revolver / turret DIN 5482
1809	Duplomatic- Revolver / turret DIN 1809
TOEM	Baruffaldi Revolver / turret
CTX / 5480	Sauter - Revolver / turret
Bsp. / Exp. : 60.30V3CTX	

*Radial
Bohr- u. Fräskopf*
EWS-Varia

*Radial drilling
and milling head*
EWS-Varia

*Tête de perçage
et fraisage, radial*
EWS-Varia

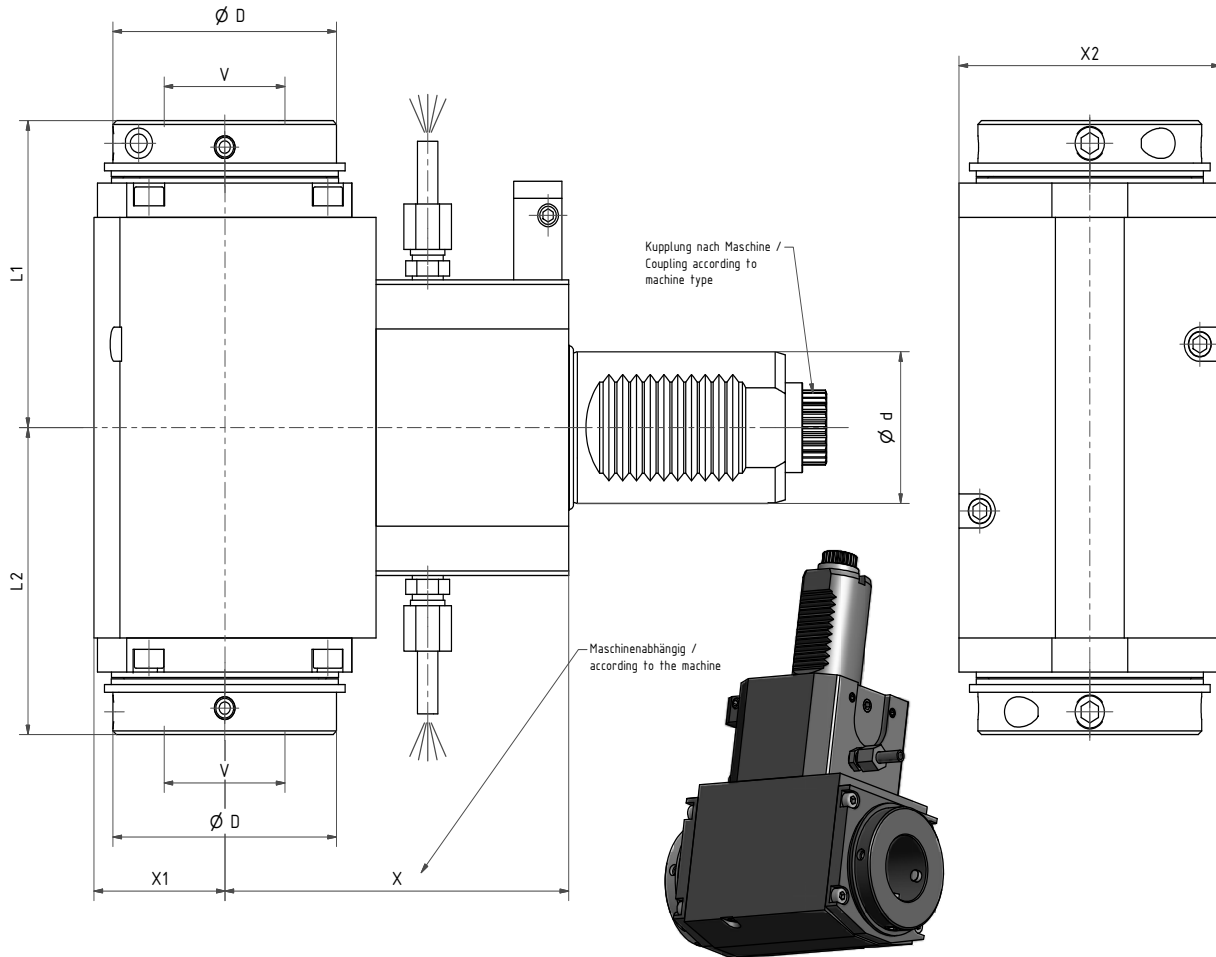

Nr. / No.	d	V	L1	L2	Ø D	X1	X2	n _{max}	T _{max}
60.25V3D...	25	V3	65,5	65,5	55	34	68	6000 1/min	25 Nm
60.30V3D...	30	V3	65,5	65,5	55	34	68	6000 1/min	25 Nm
60.40V4D...	40	V4	93	76	65	34	88	6000 1/min	50 Nm
60.50V5D...	50	V5	100	125	89	52,5	110	4000 1/min	100 Nm

5482	Sauter - Revolver / turret DIN 5482
1809	Duplomatic- Revolver / turret DIN 1809
TOEM	Baruffaldi Revolver / turret
CTX / 5480	Sauter - Revolver / turret
Bsp. / Exp. : 60.30V3DCTX	

*Radial
Bohr- u. Fräskopf
zurückgesetzt*
EWS-Varia

*Radial drilling
and milling head
offset*
EWS-Varia

*Tête de perçage
et fraisage, radial*
EWS-Varia

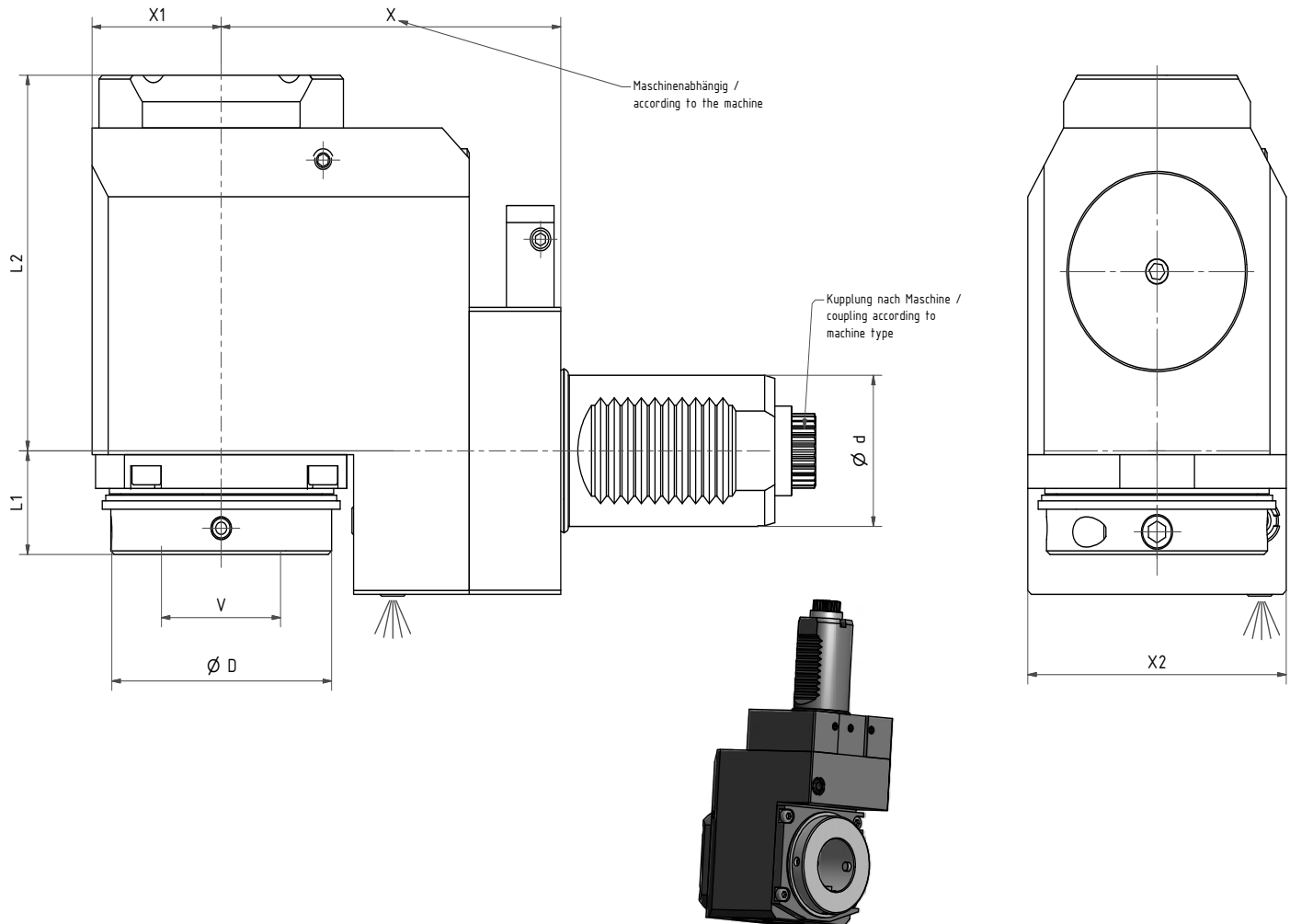

Nr. / No.	d	V	L1	L2	Ø D	X1	X2	n _{max}	T _{max}
80.25V3...	25	V3	23	83,5	55	36	68	6000 1/min	25 Nm
80.30V3...	30	V3	23	83,5	55	36	68	6000 1/min	25 Nm
80.40V4...	40	V4	27,5	99,5	65	38	76	6000 1/min	50 Nm
80.50V5...	50	V5	47	126	89	52	104	4000 1/min	100 Nm

5482	Sauter - Revolver / turret DIN 5482
1809	Duplomatic- Revolver / turret DIN 1809
TOEM	Baruffaldi Revolver / turret
CTX / 5480	Sauter - Revolver / turret
Bsp. / Exp. : 80.30V3CTX	

Spannzangen- einsatz

EWS-Varia

Collet chuck

EWS-Varia

Porte pince

EWS-Varia

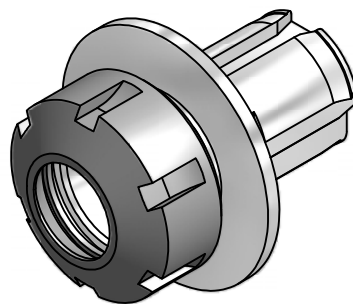
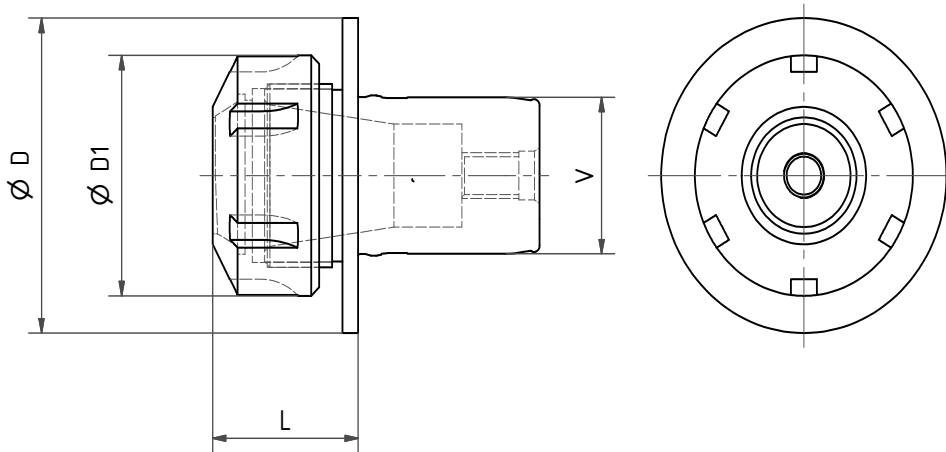

Nr. / No.	V	D	D1	L	Spannzange / collet
31.V316L27	V3	55	28	27	160 426E ER16 (Seite / Page 1.29)
31.V316L103	V3	55	27	103	160 426E ER16 (Seite / Page 1.29)
31.V320L27	V3	55	34	27	200 428E ER20 (Seite / Page 1.29)
31.V325L30	V3	55	42	30	250 430E ER25 (Seite / Page 1.29)
31.V325L60	V3	55	42	60	250 430E ER25 (Seite / Page 1.29)
31.V332L63	V3	55	50	63	320 470E ER32 (Seite / Page 1.29)
31.V416L23,5	V4	65	28	23,5	160 426E ER16 (Seite / Page 1.29)
31.V416L50	V4	65	28	50	160 426E ER16 (Seite / Page 1.29)
31.V420L25	V4	65	34	25	200 428E ER20 (Seite / Page 1.29)
31.V420L50	V4	65	34	50	200 428E ER20 (Seite / Page 1.29)
31.V425L28	V4	65	42	30	250 430E ER25 (Seite / Page 1.29)
31.V432L30	V4	65	50	30	320 470E ER32 (Seite / Page 1.29)
31.V432L35	V4	65	50	35	320 470E ER32 (Seite / Page 1.29)
31.V532L33	V5	89	50	34	320 470E ER32 (Seite / Page 1.29)
31.V540L38	V5	89	63	38	400 472E ER40 (Seite / Page 1.29)

Spannzangen- einsatz

EWS-Varia

Collet chuck

EWS-Varia

Porte pince

EWS-Varia

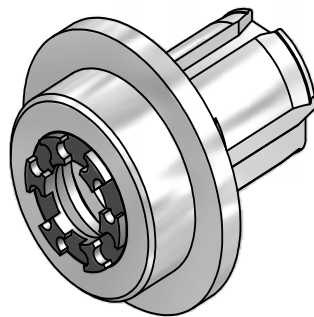
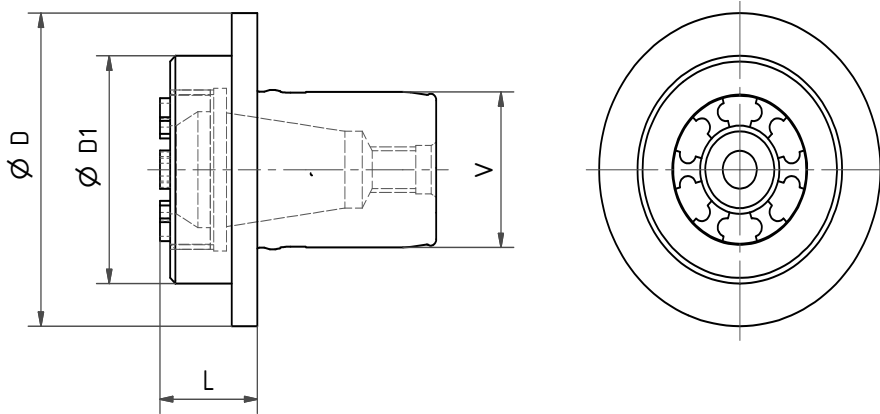

Nr. / No.	V	D	D1	L	Spannzange / collet
31.V316IML14	V3	55	34	14	160 426E ER16 (Seite / Page 1.29)
31.V316IML17	V3	55	40	18	200 428E ER20 (Seite / Page 1.29)
31.V420IML15	V4	65	38	16,5	200 428E ER20 (Seite / Page 1.29)

Weldon / whistle notch Einsatz

EWS-Varia

Weldon / whistle notch insert

EWS-Varia

Weldon / whistle notch adaptuer

EWS-Varia

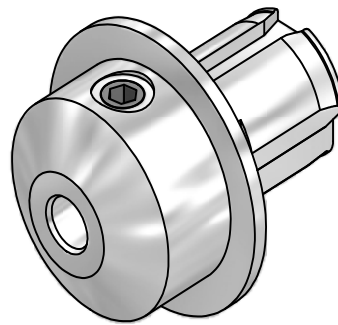
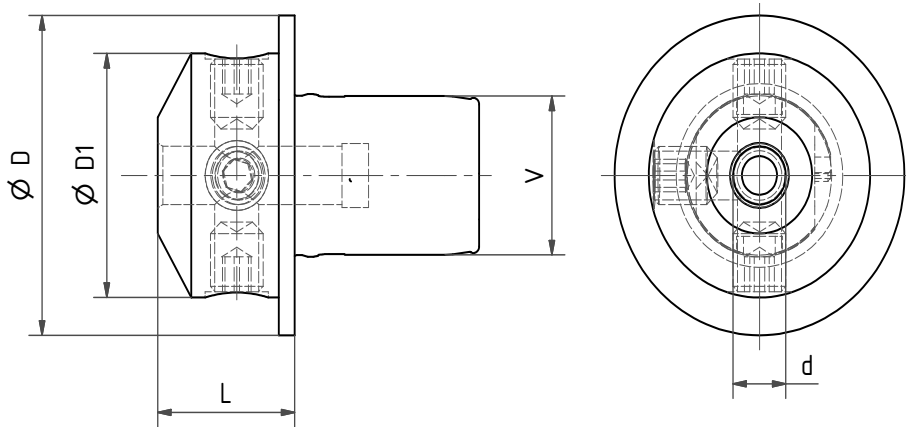

Nr. / No.	V	D	D1	L	d
27.V306WNL16	V3	55	25	16	06
27.V308WNL17	V3	55	25	17	08
27.V309,53WNL26	V3	55	42	26	9,53
27.V310WNL26	V3	55	42	26	10
27.V312WNL26	V3	55	42	26	12
27.V314WNL28	V3	55	48	28	14
27.V315,88WNL28	V3	55	48	28	15,88
27.V316WNL28	V3	55	48	28	16
27.V318WNL28	V3	55	52	28	18
27.V406WNL16	V4	65	25	16	06
27.V408WNL19	V4	65	25	19	08
27.V410WNL26	V4	65	42	26	10
27.V412WNL28	V4	65	42	28	12

Nr. / No.	V	D	D1	L	d
27.V414WNL28	V4	65	48	28	14
27.V416WNL28	V4	65	48	28	16
27.V418WNL28	V4	65	52	28	18
27.V420WNL28	V4	65	52	28	20
27.V425WNL33	V4	65	60	33	25
27.V506WNL19	V5	89	25	19	06
27.V508WNL22	V5	89	28	22	08
27.V510WNL29	V5	89	35	29	10
27.V512WNL31	V5	89	42	31	12
27.V516WNL31	V5	89	48	31	16
27.V520WNL31	V5	89	52	31	20
27.V525WNL36	V5	89	65	36	25
27.V532WNL56	V5	89	72	56	32

Fräseinsatz
EWS-Varia

Millering insert
EWS-Varia

Fraisage adapteur
EWS-Varia

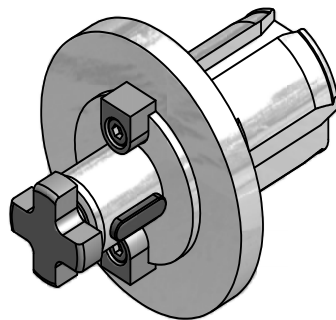
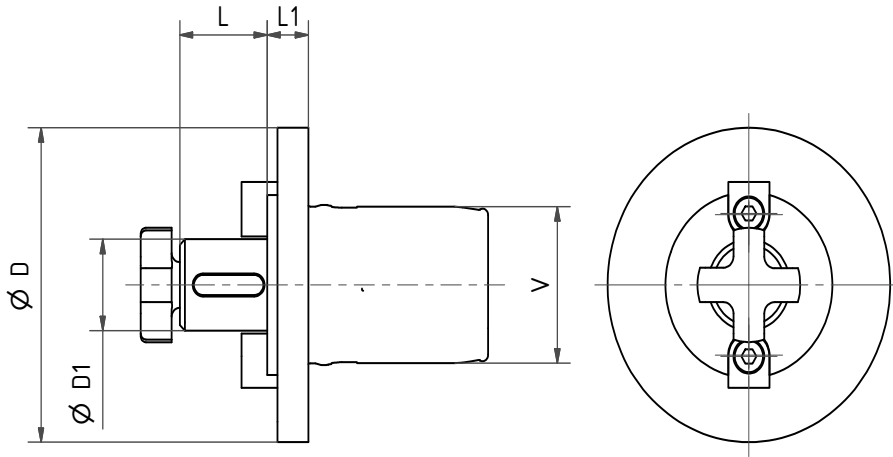

Nr. / No.	V	L	L1	D	D1
42.V308L28	V3	28	12	55	08
42.V310L28	V3	28	12	55	10
42.V313L08,5	V3	08,5	12	55	13
42.V316L08	V3	08	17	55	16
42.V322L08	V3	08	19	55	22
42.V327L08	V3	08	21	55	27
42.V416L08	V4	08	17	65	16
42.V422L08	V4	08	19	65	22
42.V427L08	V4	08	21	65	27
42.V516L08	V5	08	17	89	16
42.V522L08	V5	08	19	89	22
42.V527L12	V5	12	21	89	27

*Hydrodehn
Einsatz*
EWS-Varia

*Hydrodehn
insert*
EWS-Varia

*Hydrodehn
adapteur*
EWS-Varia

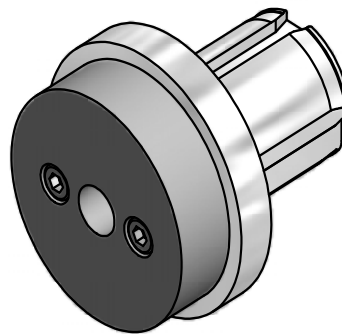
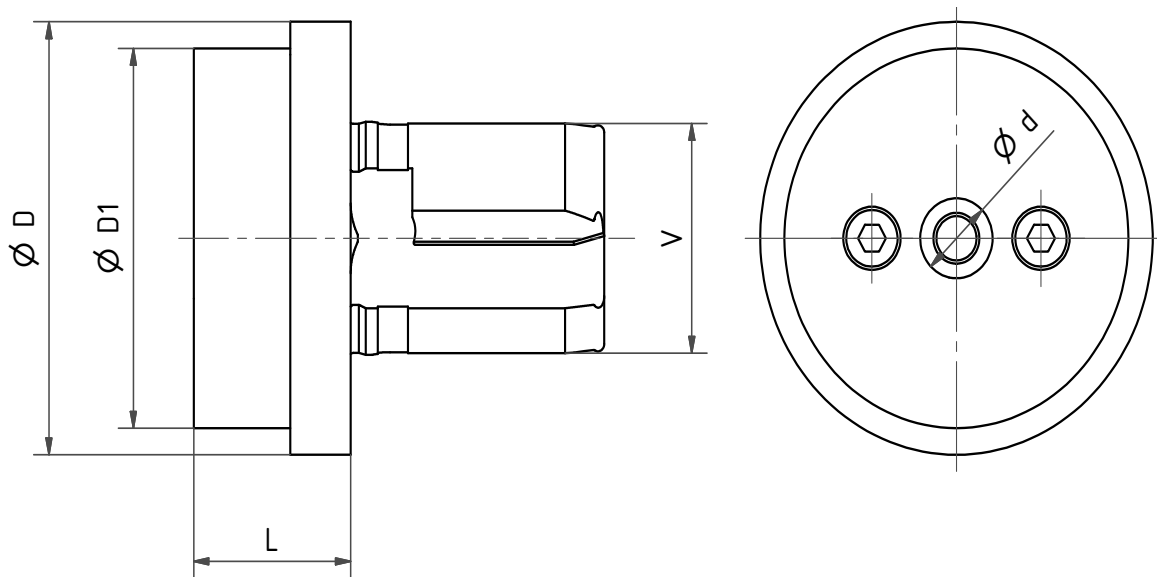

Nr. / No.	V	D	D1	L	d
27.V312HYDL26	V3	55	57	26	12
27.V412HYDL26	V4	65	57	26	12
auf Anfrage / on request :					
27.V512HYDL26	V5	89	57	26	12

Pendelhalter
Spannzangeneinsatz
 EWS-Varia

Floating toolholder
Collet chuck
 EWS-Varia

Porte-outil flottant
Porte prince
 EWS-Varia

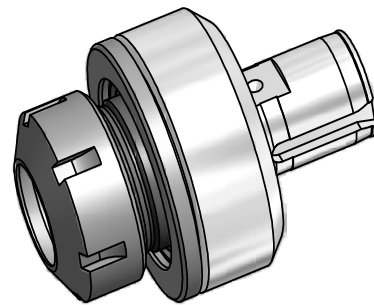
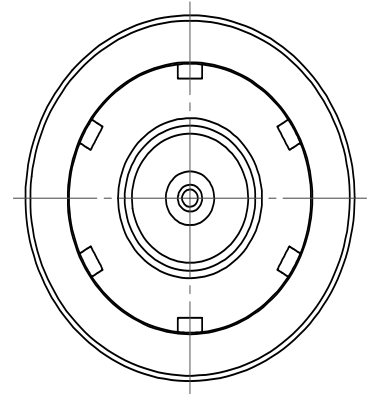
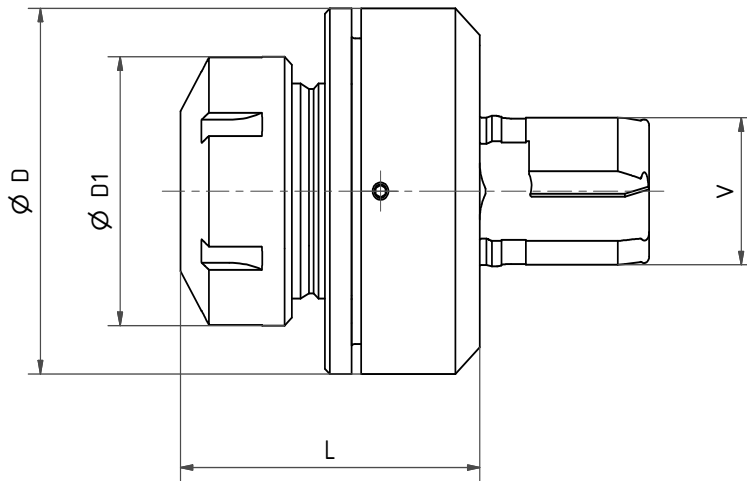

Nr. / No.	V	D	D1	L	Spannzange / collet
PH31.V332L63	V3	68	50	63	320 470E ER32 (Seite / Page 1.29)
PH31.V432L82	V4	68	50	82	320 470E ER32 (Seite / Page 1.29)
PH31.V532L63	V5	89	50	63	320 470E ER32 (Seite / Page 1.29)

Morsekegel

EWS-Varia

Morse Taper Adaptor

EWS-Varia

Porte outil à cone Morde

EWS-Varia

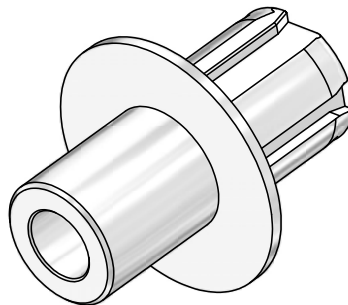
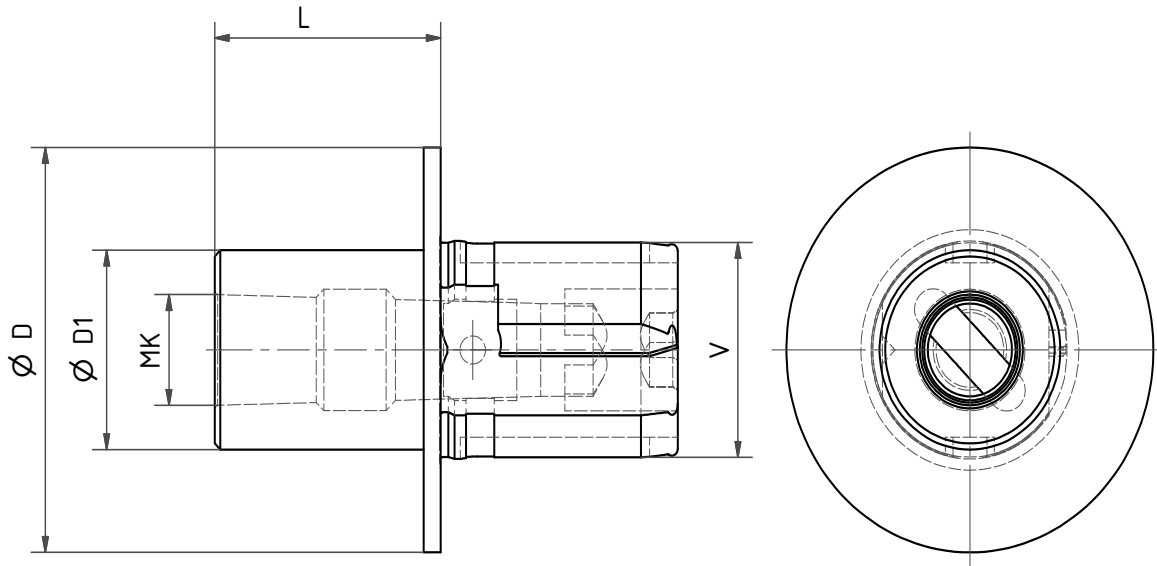

Nr. / No.	V	D	D1	L	MK
25.V410L30	V4	65	25	63	1
25.V420L40	V4	65	32	32	2
25.V510L15	V5	89	39	15	1
25.V520L36	V5	89	39	36	2
25.V530L52	V5	89	45	52	3

Bohrstangenhalter

Boring bar holder

Porte barre d'alésage

EWS-Varia

EWS-Varia

EWS-Varia

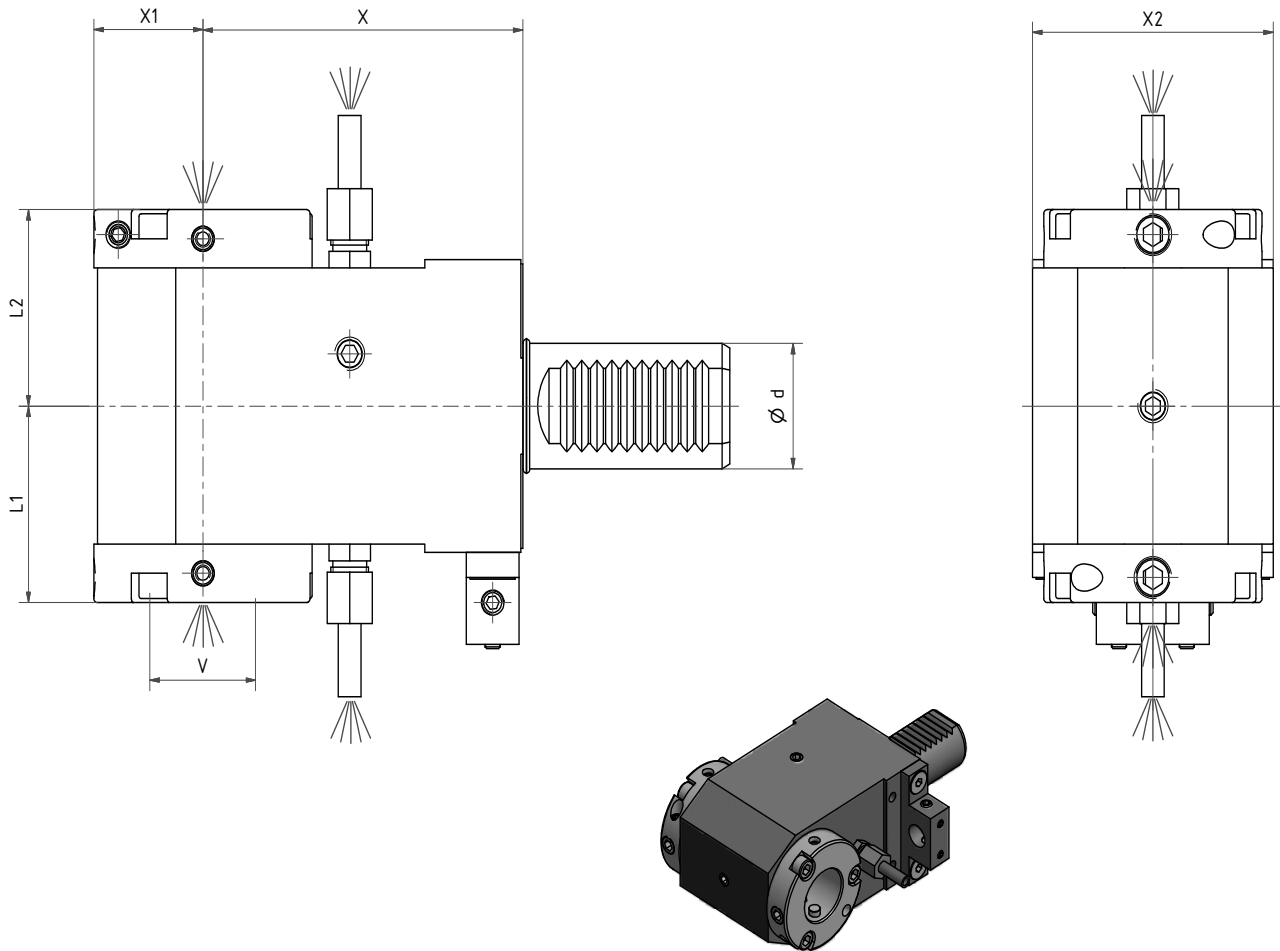

Nr. / No.	d	V	L1	L2	X1	X2	X
17.30V3...	30	V3	37,5	37,5	28	64	85
17.30V3L...	30	V3	37,5	37,5	28	64	100
17.40V4...	40	V4	42,5	42,5	34	76	100
17.40V4L...	40	V4	42,5	42,5	34	76	120
auf Anfrage / on request :							
17.50V5L	50	V5					

X-Maß und Ausrichtsystem nach Maschine

X-dimension and adjusting system according to machine type

*Montageblock und
Messvorrichtung*
EWS-Varia

*Assembly block and
measuring fixture*
EWS-Varia

*Bloc de montage
et pour mesure*
EWS-Varia

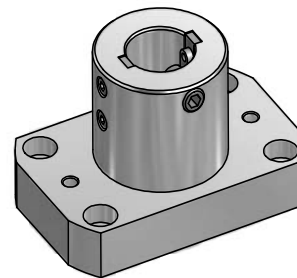
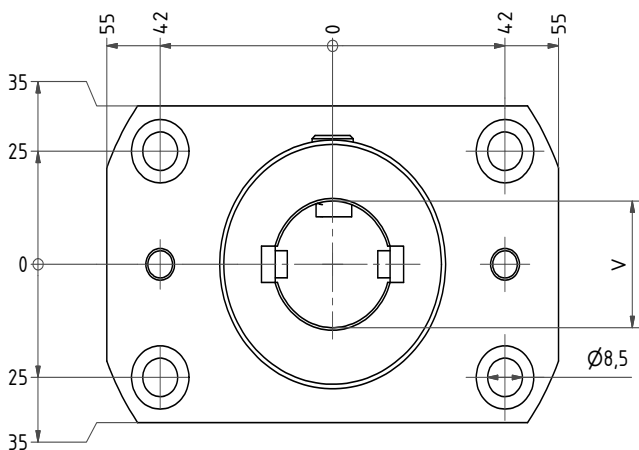
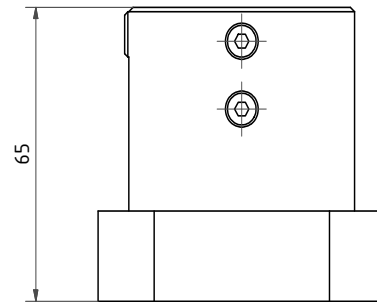
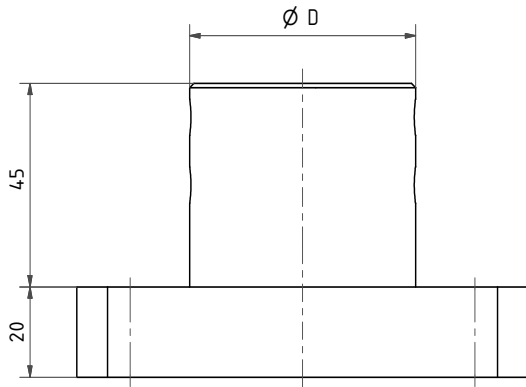

Nr. / No.	V	ØD
MB-V3	V3	55
MB-V4	V4	65
MB-V5	V5	89

*Adapter für Werkzeug
Einstellgeräte*
EWS-Varia

*Adapter for
Pre-Setter*
EWS-Varia

*Adapteur pour
Appareil de Prérélage*
EWS-Varia

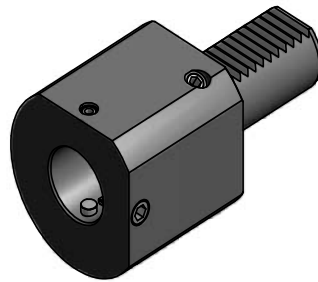
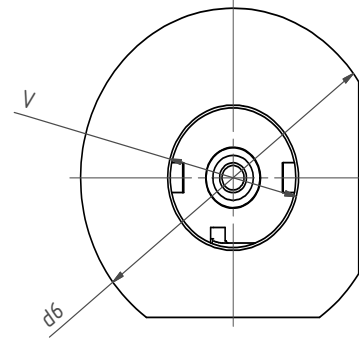
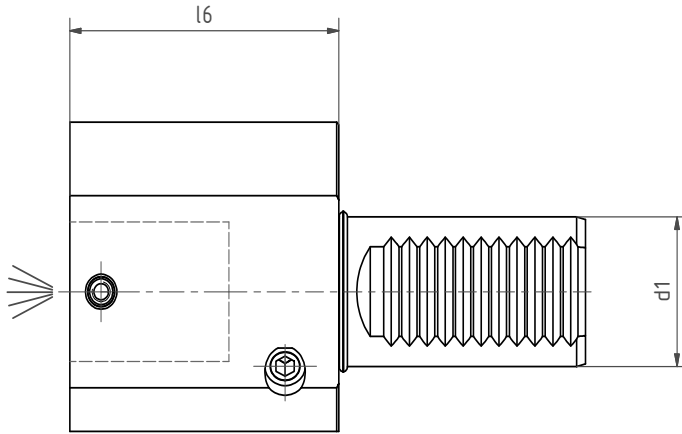

Nr. / No.	V	d1	d6	l6
19.25V3	V3	25	58	48
19.30V3	V3	30	68	48
19.40V4	V4	40	83	48
auf Anfrage / on request :				
19.50V5	V5	50	89	48



EWS Weigele GmbH & Co. KG

Maybachstraße 1 · D-73066 Uhingen
Telefon +49(0)7161-93040-100
Telefax +49(0)7161-93040-30
E-Mail: info@ews-tools.de
www.ews-tools.de

WSW Spannwerkzeuge-Vertriebs GmbH

Maybachstr. 1 · D-73066 Uhingen
Telefon +49(0)7161-93040-100
Telefax +49(0)7161-93040-30
E-Mail: info@wsw-collets.de
www.wsw-collets.de

Command Tooling Systems

13931 Sunfish Lake Blvd NW
Ramsey · MN 55303 USA
Telefon +1-763-576-6910
Telefax +1-763-576-6911
support@commandtool.com
www.commandtool.com

EWS Korea Co. Ltd.

60-11 · Woongnam-Dong
Changwon
Kyoung-Nam Korea
Telefon +82 55-267-8085
Telefax +82 55-262-3118
E-Mail: info@ewskorea.co.kr
www.ewskorea.co.kr

EWS Ltd.

B. Nizhegorodskaya str., 81
office 806
600000 Vladimir
Russland
Telefon +7-4922-490420
Telefax +7-4922-451828
E-Mail: info@ews-russland.ru





Precision meets Motion

2011.1